

TABLE OF CONTENTS

Needle Bar 3-2

Clamping/Unclamping 3-4

Thread Trimmer 3-6

Shifter Mechanism 3-8

Stop / Start Mechanism 3-10

Feed Mechanism 3-12

Looper Mechanism 3-14

Base 3-16

Bite Mechanism 3-18

Clutch Mechanism 3-20

Knife Mechanism 3-22

Main Cam 3-24

Head 3-26

Bedplate 3-28

Covers 3-30

Tables 3-32

Accesories 3-40

ISBH Models

Main Cam 3-42

Thread Draw-Off. 3-44

Clamping. 3-46

Pneumatics 3-48

TABLE OF CONTENTS

ISBH with Indexer

Base	3-50
Bedplate	3-51
Lubrication.	3-52
Needle Chart	3-54

Revised 4/98

U.S. Phone (800) 237-3323 Fax (800) 432-4303

Outside U.S. Phone (804) 559-5000 Fax (804) 559-5290

This page intentionally left blank.

Released June 1996

U.S. Phone (800) 237-3323 Fax (800) 432-4303

Outside U.S. Phone (804) 559-5000 Fax (804) 559-5290

3-1

NEEDLE BAR

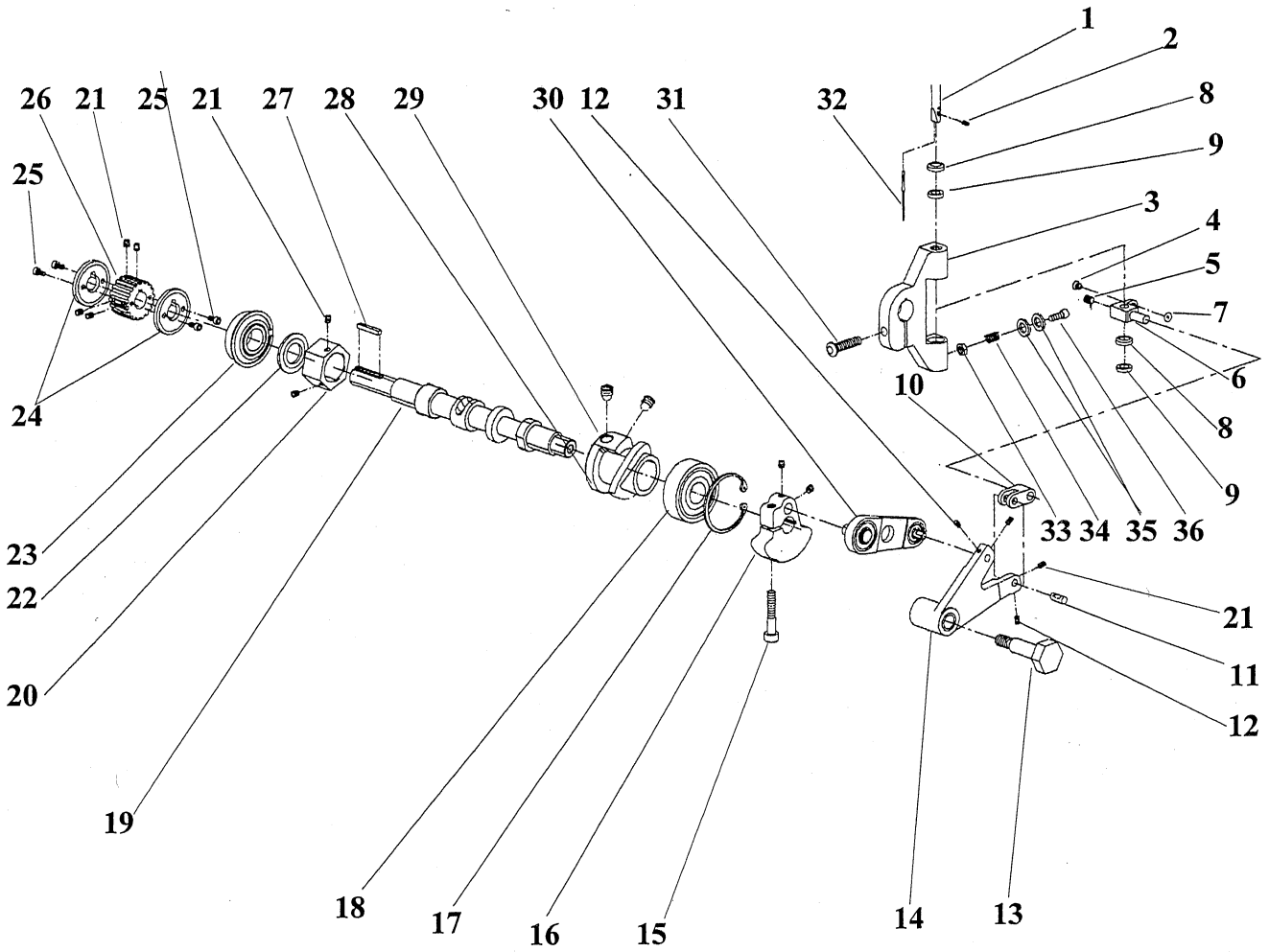

NEEDLE BAR

DET	PART NUMBER	DESCRIPTION
01	22.0195.0.000	Needle Bar
02	01.2193.0.000	4-60 Screw
03	22.0510.0.000	Needle Bar Holder
04	01.7447.1.000	Porcelain Guide
05	08.6400.5.005	M5 x 5 Screw
06	22.0520.0.000	Needle Bar Clamp
07	01.6551.0.000	Retaining Ring
08	20.0587.0.000	Cupped Washer
09	20.0588.0.000	Felt Washer
10	22.0530.0.000	Needle Bar Connecting Link
11	22.0542.0.000	Needle Bar Connecting Link Pin
12	08.6400.3.005	M3 x 5 Screw
13	22.0541.0.000	Needle Bar Shoulder Screw
14	22.0540.0.000	Needle Bar Connecting Link Pin
15	08.6000.6.030	M6 x 30 Screw
16	22.0525.0.000	Needle Bar Crank
17	01.7809.0.000	Retaining Ring
18	01.7804.0.000	Top Shaft Bearing
19	22.0500.0.000	Needle Bar Drive Shaft
20	22.0544.0.000	Nut
21	08.6400.4.004	M4 x 4 Screw
22	22.0545.0.000	Head Shaft Washer
23	01.7805.0.000	Shaft Bearing w/Snap Ring
24	22.0506.0.000	Pulley Flange
25	08.6000.3.006	M3 x 6 Screw
26	22.0505.0.000	Needle Bar Drive Pulley
27	22.0175.0.000	Drive Shaft Key
28	22.1400.0.000	Knife Cam
29	22.0077.0.000	Knife Cam Screw
30	22.0535.0.100	Needle Bar Crank Link Asm.
31	08.6200.6.025	M6 x 25 Screw
32	See Needle Chart	Needle
33	22.0179.0.000	M3.5 x 0.35 Nut
34	22.0178.0.000	Spring
35	22.0177.0.000	Washer
36	22.0176.0.000	M3.5 x 0.35-13.5 Screw

Revised 2/98

U.S. Phone (800) 237-3323 Fax (800) 432-4303

Outside U.S. Phone (804) 559-5000 Fax (804) 559-5290

CLAMPING/UNCLAMPING

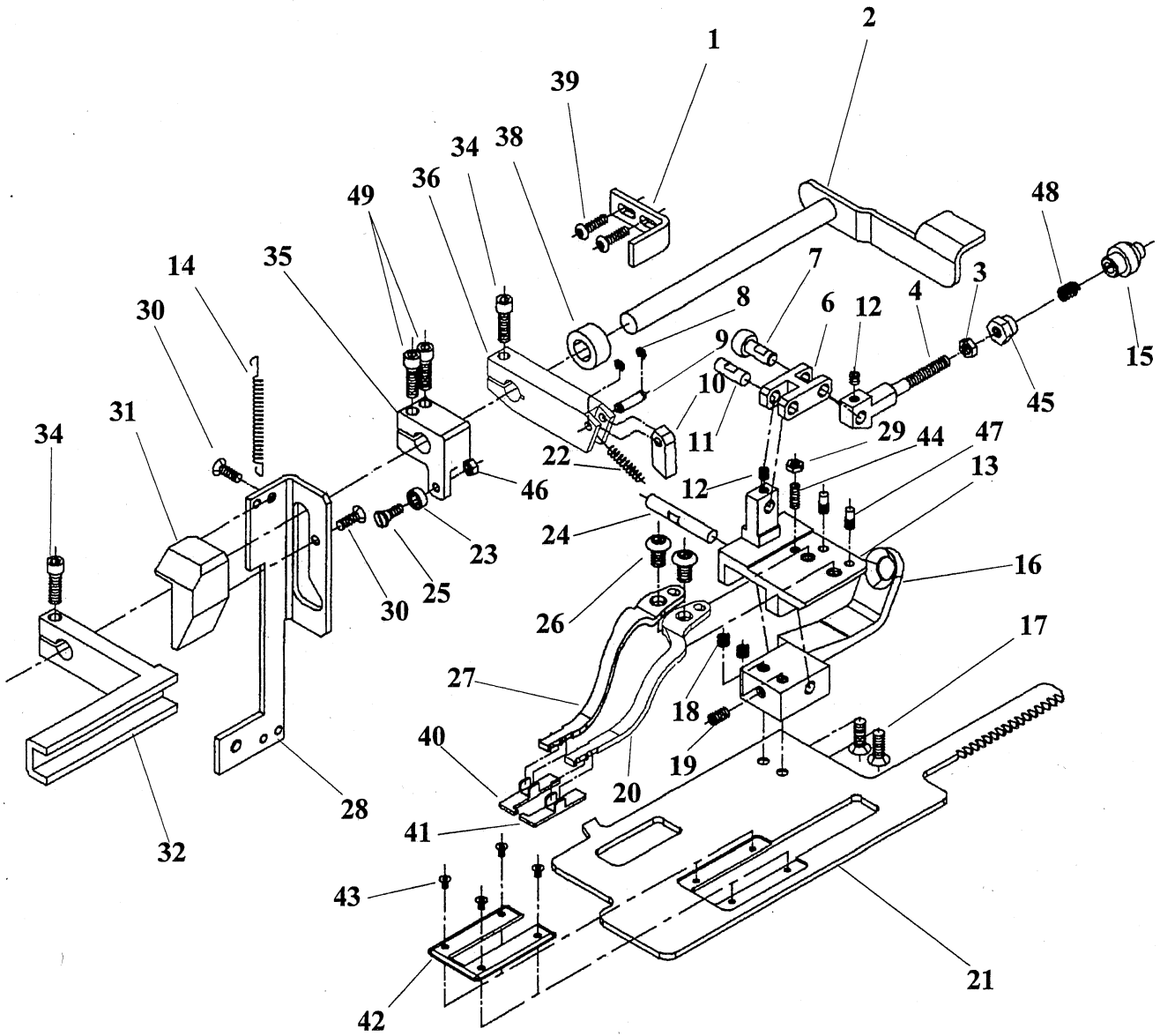

CLAMPING/UNCLAMPING

DET	PART NUMBER	DESCRIPTION	DET	PART NUMBER	DESCRIPTION
01	22.0403.0.000	Pawl Retainer	25	22.0180.0.000	Pivot
02	22.0068.0.000	Clamp Arm	26	08.6000.6.008	M6 x 8 Cap Screw
03	08.6700.5.000	M5 Nut	27	22.0092.0.000	Right Clamp Arm
04	22.0174.0.000	Toggle	28	22.0043.0.000	Clamping Cam
06	22.0140.0.000	Clamping Connecting Link	29	08.6700.4.000	M4 Hex Nut
07	22.0170.0.000	Clamping Ball Stud	30	08.6100.4.010	M4 x 10 FH Screw
08	07.6045.0.047	E-ring	31	22.0016.0.000	Clamping Retainer
09	22.0404.0.000	Unclamping Pin	32	22.0127.0.000	Clamp Actuation Lever Asm.
10	22.0407.0.000	Pawl	34	08.6000.5.020	M5 x 20 Screw
11	22.0173.0.000	Clamp Toggle Pivot Pin	35	22.0071.0.000	Clamping Actuator Arm
12	08.6400.4.004	M4x4 Set Screw	36	22.0406.0.000	Pawl Holder
13	22.0157.0.000	Tail Pivot Clamp	38	22.0072.0.000	Pawl Holder Spacer
14	07.6440.0.029	Spring	39	08.6000.4.008	M4 x 8 Cap Screw
15	22.0171.0.000	Clamp Pivot Bushing	40	20.0196.1.336	Left Clamp Foot
16	22.0158.0.000	Tail Bracket Clamp		20.0196.1.330	Left Clamp Foot*Large
17	08.6100.5.012	M5 x 12 FH Screw	41	20.0196.1.337	Right Clamp Foot
18	07.6440.0.030	Spring		20.0196.1.331	Right Clamp Foot*Large
19	08.6400.5.010	M5 x 10 Set Screw	42	20.0164.0.000	Clamping Mat
20	22.0093.0.000	Left Clamp Arm	43	01.2376.0.000	4-60 Screw
21	22.0125.0.000	Clamp Plate	44	08.6400.4.012	M4 x 12 Set Screw
22	07.6440.0.031	Spring	45	22.0050.0.000	Toggle Clamp Nut
23	22.0056.0.000	Roll	46	08.6700.5.000	M5 Hex Nut
24	22.0159.0.000	Tail Pivot Clamp Pin	47	07.6045.0.046.	4 x 10 Pin
			48	07.6440.0.044	Spring
			49	08.6000.4.020	M4 x 20 Cap Screw

Revised 2/98

U.S. Phone (800) 237-3323 Fax (800) 432-4303

Outside U.S. Phone (804) 559-5000 Fax (804) 559-5290

THREAD TRIMMER

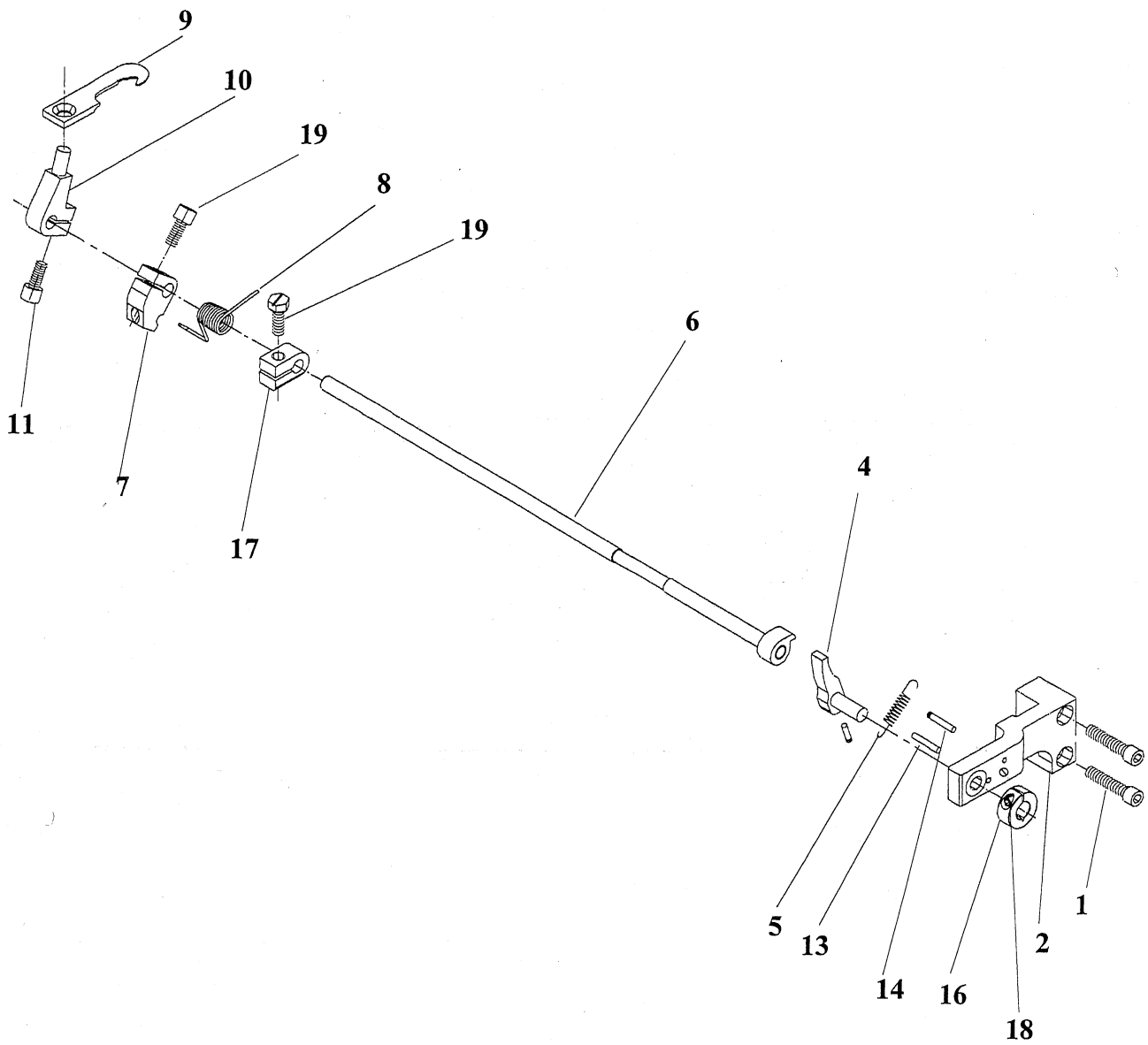

THREAD TRIMMER

DET	PART NUMBER	DESCRIPTION
01	08.6000.5.025	M5 x 25 Screw
02	22.0082.0.000	Trimmer Arm
04	20.0641.2.000	Pawl Assembly
05	01.5033.0.000	Spring
06	22.0080.0.000	Trimmer Shaft Assembly
07	22.0166.0.000	Stop Arm
08	01.5162.0.000	Torsion Spring
09	20.0093.2.004	Trimmer Hook
10	20.0092.0.004	Trimmer Actuator
11	01.2386.0.000	3/16-36 x .500L Hex Screw
13	07.6045.0.049	3x12mm Dowel Pin
14	07.6045.0.009	3 x 12mm Grooved Pin
16	22.0014.0.000	1/4" ID Collar
17	22.0074.0.000	Trimmer Stop
18	22.0181.0.000	Set Screw
19	08.6000.5.012	M5 x 12 Screw

Revised 2/98

U.S. Phone (800) 237-3323 Fax (800) 432-4303

Outside U.S. Phone (804) 559-5000 Fax (804) 559-5290

SHIFTER MECHANISM

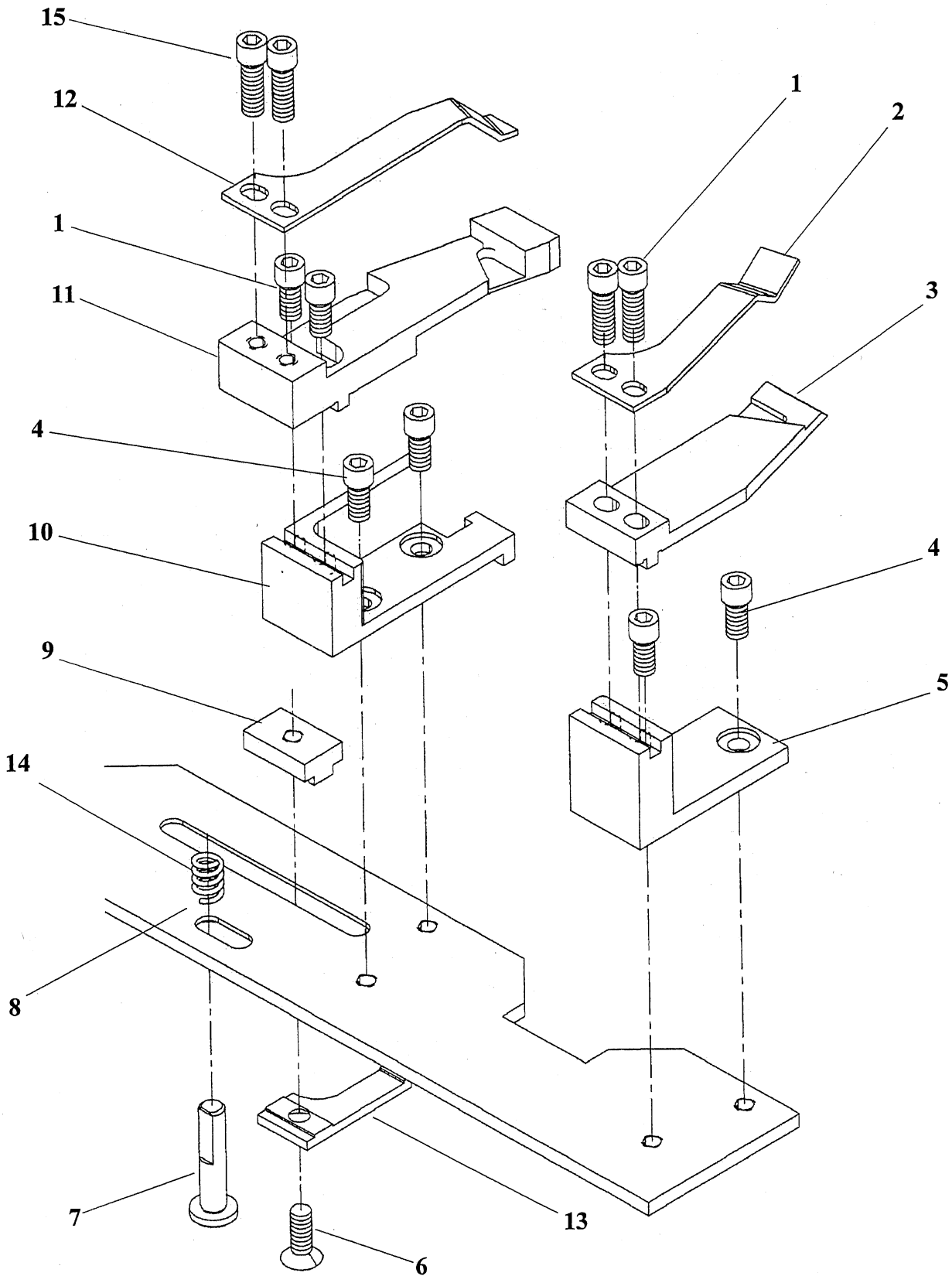

SHIFTER MECHANISM

DET	PART NUMBER	DESCRIPTION
01	08.6000.4.012	M4 x 12 Screw
02	22.2657.0.000	Right Shifter Arm Spring
03	22.2656.0.000	Right Shift Arm
04	08.6000.4.005	M4 x 5 Screw
05	22.2655.0.000	Right Shifter Block
06	08.6100.4.006	M4 x 6 Screw
07	22.0400.0.000	Spring Load Pin
08	22.2665.0.000	Man Cam Shifter Plate
09	22.0405.0.000	Adjustable Link Nut
10	22.2651.0.000	Left Shifter Block
11	22.2652.0.000	Left Shifter Arm
12	22.2653.0.000	Left Shifter Arm Spring
13	22.2664.0.000	Buttonhole Adjusting Link
14	07.6440.0.040	Spring
15	08.6000.4.010	M4 x 10 Screw

Revised 2/98

U.S. Phone (800) 237-3323 Fax (800) 432-4303

Outside U.S. Phone (804) 559-5000 Fax (804) 559-5290

STOP/START MECHANISM

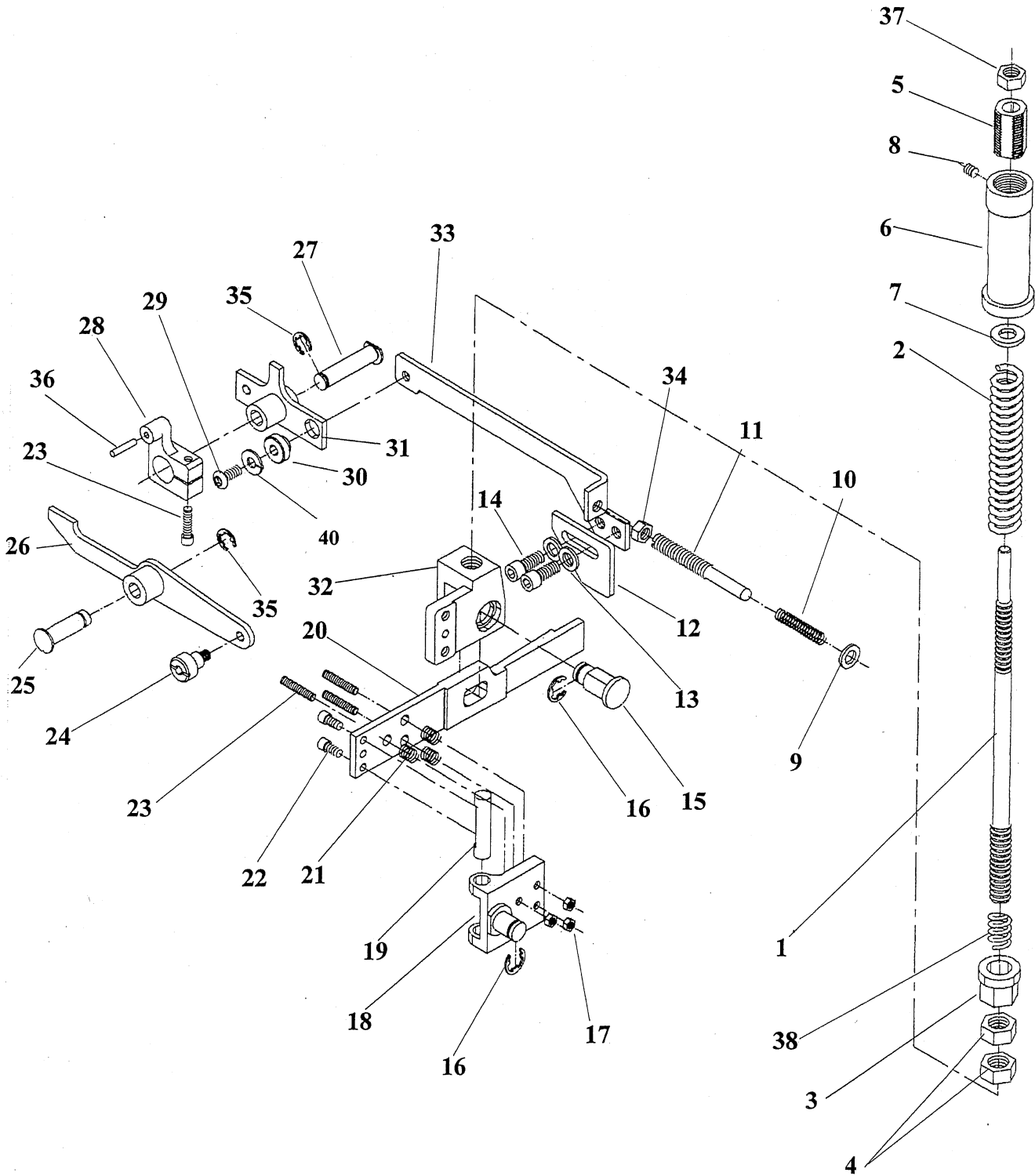

STOP/START MECHANISM

DET	PART NUMBER	DESCRIPTION
01	22.6214.0.000	Stop Bolt
02	07.6440.0.025	Compression Spring
03	22.6213.0.000	Stop Bolt Nut
04	08.6700.0.000	M10 Nut
05	22.0401.0.000	Unclamping Adjusting Screw
06	22.0402.0.000	Unclamping Cylinder
07	22.0073.0.000	Stop Bolt Spacer Spring
08	08.6400.4.006	M4 x 6 Screw
09	22.0100.0.000	Washer
10	07.6440.0.027	Compression Spring
11	22.0076.0.000	Stop/Start Stud
12	22.0045.0.000	Starting Lever Plate
13	08.6800.6.000	M6 Lock Washer
14	08.6000.6.008	M6 x 8 Cap Screw
15	22.6211.0.000	Stop Lever Clevis Pin
16	07.6045.0.002	E-Clip
17	08.6710.4.000	M4 Nut
18	22.6210.0.000	Stop Lever Pivot Lever
19	22.6204.0.000	Stop Lever Pivot Pin
20	22.6202.0.000	Stop Lever
21	07.6440.0.020	Compression Spring
22	08.6000.4.010	M4 x 10 Screw
23	08.6400.4.020	M4 x 20 Screw
24	22.0182.0.000	M5 x 4 Screw Dia.6
25	22.0168.0.000	Engaging Lever Pin
26	22.0075.0.000	Engaging Lever
27	22.0095.0.000	Stop Toggle Pin
28	22.0084.0.000	Knock Off Adjusting Lever
29	08.6000.5.012	M5 x 12 Screw
30	22.0089.0.000	Shoulder Nut
31	22.6265.0.000	Stop/Start Toggle Arm
32	22.6212.0.000	Stop Lever Clevis
33	22.6225.0.000	Starter Lever
34	08.6710.8.400	M8 Nut
35	07.6045.0.043	E-Ring Dia.7
36	08.6900.3.020	3 x 20 Dowel Pin
37	08.6710.8.400	M8 Nut
38	07.6440.0.021	Compression Spring
40	08.6800.5.000	M5 Lock Washer

Revised 2/98

U.S. Phone (800) 237-3323 Fax (800) 432-4303

Outside U.S. Phone (804) 559-5000 Fax (804) 559-5290

FEED MECHANISM

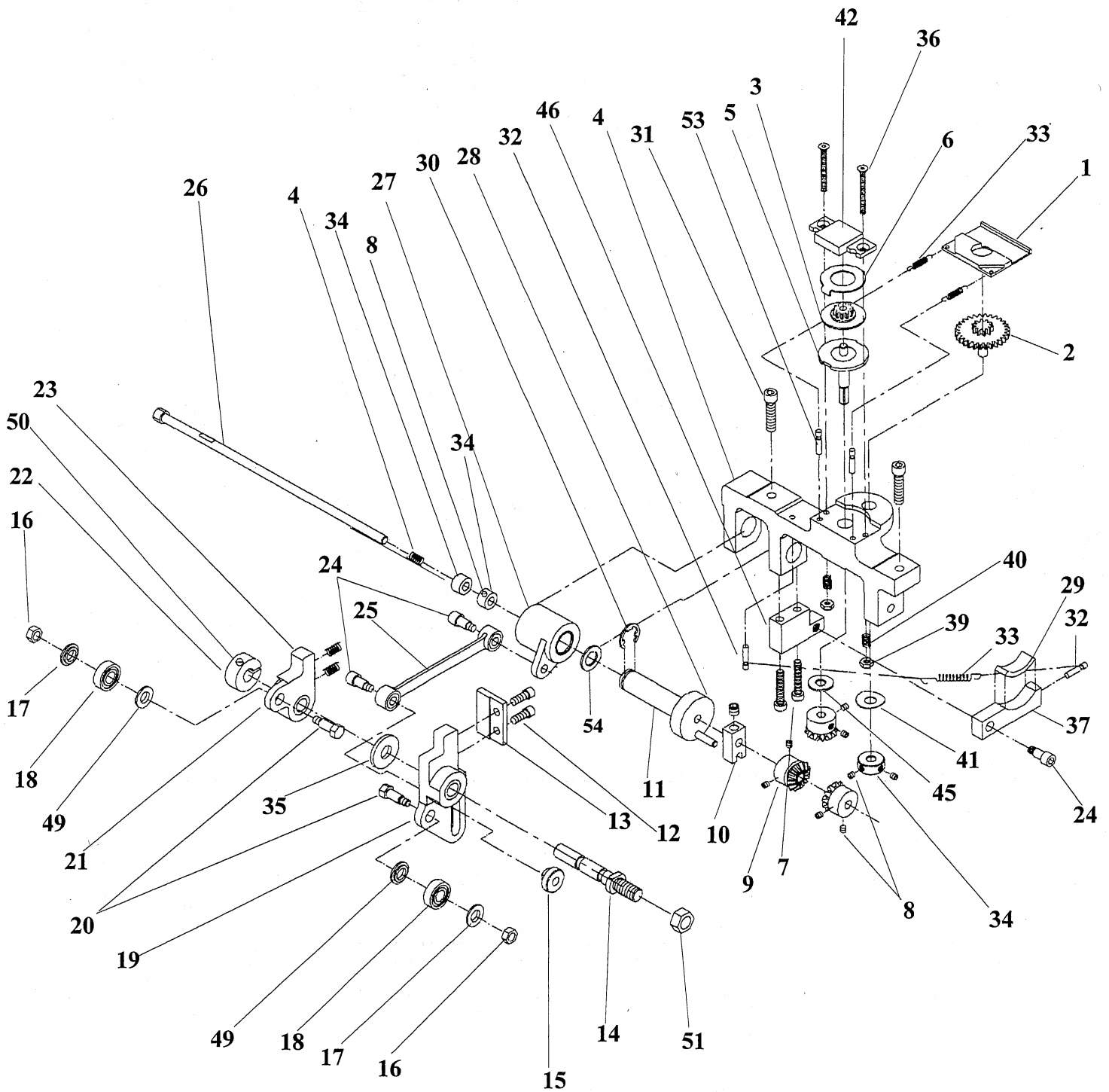

FEED MECHANISM

DET	PART NUMBER	DESCRIPTION	DET	PART NUMBER	DESCRIPTION
01	22.0061.0.000	Clamp Plate Gear Rack Retainer	26	22.0325.0.000	Feed Shaft
02	22.0351.0.000	Feed Gear Assembly	27	22.0320.0.000	Feed Shaft Bearing Housing
03	22.0354.0.000	Slip Clutch Feed Gear	28	08.6400.5.005	M5 x 5 Set Screw
04	22.0315.0.000	Feed Shaft Bracket	29	22.0313.0.000	Feed Brake Pad
05	22.0312.0.000	Slip Clutch Feed Shaft	30	07.6045.0.034	E-Ring
06	22.0121.0.000	Slip Clutch Drive Washer	31	08.6000.5.020	M5 x 20mm Cap Screw
07	08.6400.4.025	M4 x 25 Soc. Hd. Cap Screw	32	07.6045.0.009	3 x 12mm Pin
08	08.6400.4.005	M4 x 5 Set Screw	33	07.6440.0.033	Spring
09	22.0353.0.000	Bevel Gear*Steel	34	22.0117.0.000	Set Collar
10	22.0370.0.000	Feed Shaft Drive Bushing Crank	35	01.4980.0.000	8mm ID Flat Washer
11	22.0336.0.000	Feed Shaft Drive Bushing	36	08.6100.3.030	M3 x 30 FH Screw
12	08.6000.4.014	M4 x 14 Soc. Hd. Screw	37	22.0309.0.000	Feed Brake
13	22.0021.0.000	Spring Retainer Block	39	08.6733.3.000	M3 Lock Nut
14	22.0022.0.000	Pivot Shaft	40	07.6440.0.028	Spring
15	22.0110.0.000	M5 Shoulder Nut	41	17.0019.2.057	Lockwasher
16	08.6710.5.000	M5 Nut	42	22.0114.0.000	Feed Brake Pressure Plate
17	22.0100.0.000	Shoulder Washer	44	07.6440.0.041	Spring
18	07.6321.0.025	Cam Follower Bearing	45	22.0186.0.000	Washer Dia. 5.2/15-0.2
19	22.0025.0.000	R.H. Feed Cam Follower	46	22.0049.0.000	Feed Brake Mounting Block
20	22.0032.0.000	Looper Feed Foll. Bearing Screw	49	22.0031.0.000	Bearing Spacer
21	22.0026.0.000	L.H. Feed Cam Follower	50	08.6000.3.010	M3 x 10mm Screw
22	22.0183.0.000	Collar Dia.8	51	08.6700.8.000	M8 Nut
23	07.6440.0.018	Compression Spring	52	08.6800.4.000	M4 Lockwasher
24	22.0184.0.000	M5x8 Screw Dia.8	53	07.6045.0.037	M3 x 16 Grooved Pin
25	22.0305.0.000	Feed Connecting Link	54	17.0019.0.517	Washer

Revised 2/98

U.S. Phone (800) 237-3323 Fax (800) 432-4303

Outside U.S. Phone (804) 559-5000 Fax (804) 559-5290

LOOPER MECHANISM

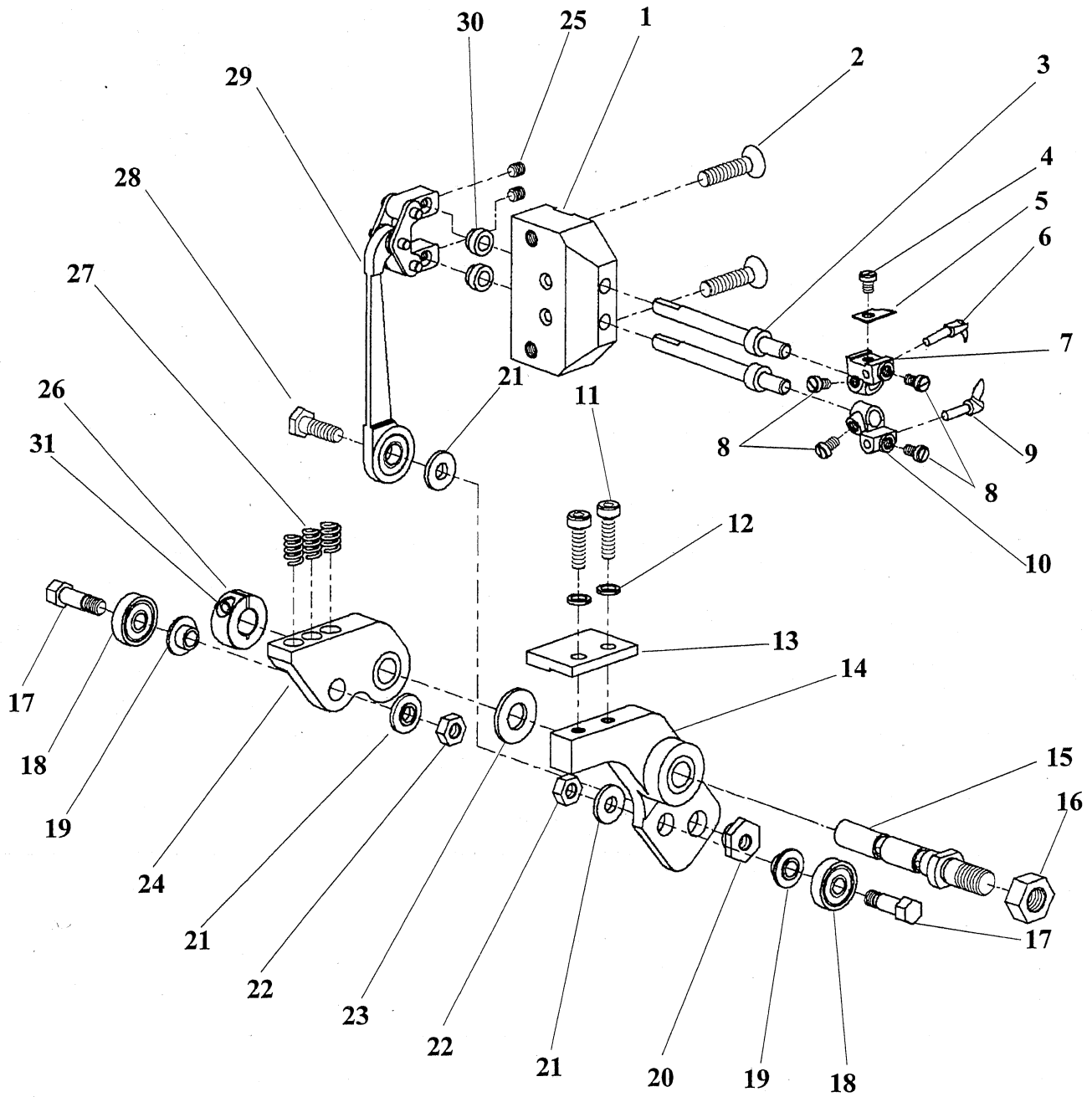

LOOPER MECHANISM

DET	PART NUMBER	DESCRIPTION
01	22.2410.0.000	Looper Shaft Block
02	08.6100.5.020	M5 x 20 FSH Cap Screw
03	22.2440.0.000	Looper Shaft
04	01.1382.0.000	Screw
05	20.0094.0.000	Trimmer Knife
06	20.0111.0.000	First Looper
07	23.2106.0.000	First Looper Holder
08	01.1397.0.000	Screw
09	20.0112.0.000	Second Looper
10	23.2107.0.000	Second Looper Holder
11	08.6000.4.014	M4 x 14 Screw
12	08.6800.4.000	M4 Lock Washer
13	22.0021.0.000	Spring Retainer Block
14	22.0023.0.000	Right Looper Cam Follower Plate
15	22.0022.0.000	Pivot Shaft
16	08.6700.8.000	M8 Hex Nut
17	22.0032.0.000	Looper Feed Foll. Bearing Screw
18	07.6321.0.025	Cam Follower Bearing
19	22.0031.0.000	Bearing Spacer
20	22.0105.0.000	Looper Eccentric Nut
21	22.0100.0.000	Shoulder Washer
22	08.6710.5.000	M5 Hex Nut
23	01.4980.0.000	Flat Washer
24	22.0024.0.000	Looper Cam Follower Plate
25	08.6400.4.004	M4 x 4 Screw
26	22.0183.0.000	Collar*Dia.8
27	07.6440.0.036	Compression Spring
28	22.0064.0.000	Bite Should Screw
29	22.2425.0.050	Looper Link Assembly
30	22.2442.0.000	Looper Spacer
31	08.6000.3.010	M3 x 10 Screw

Revised 2/98

U.S. Phone (800) 237-3323 Fax (800) 432-4303

Outside U.S. Phone (804) 559-5000 Fax (804) 559-5290

BASE

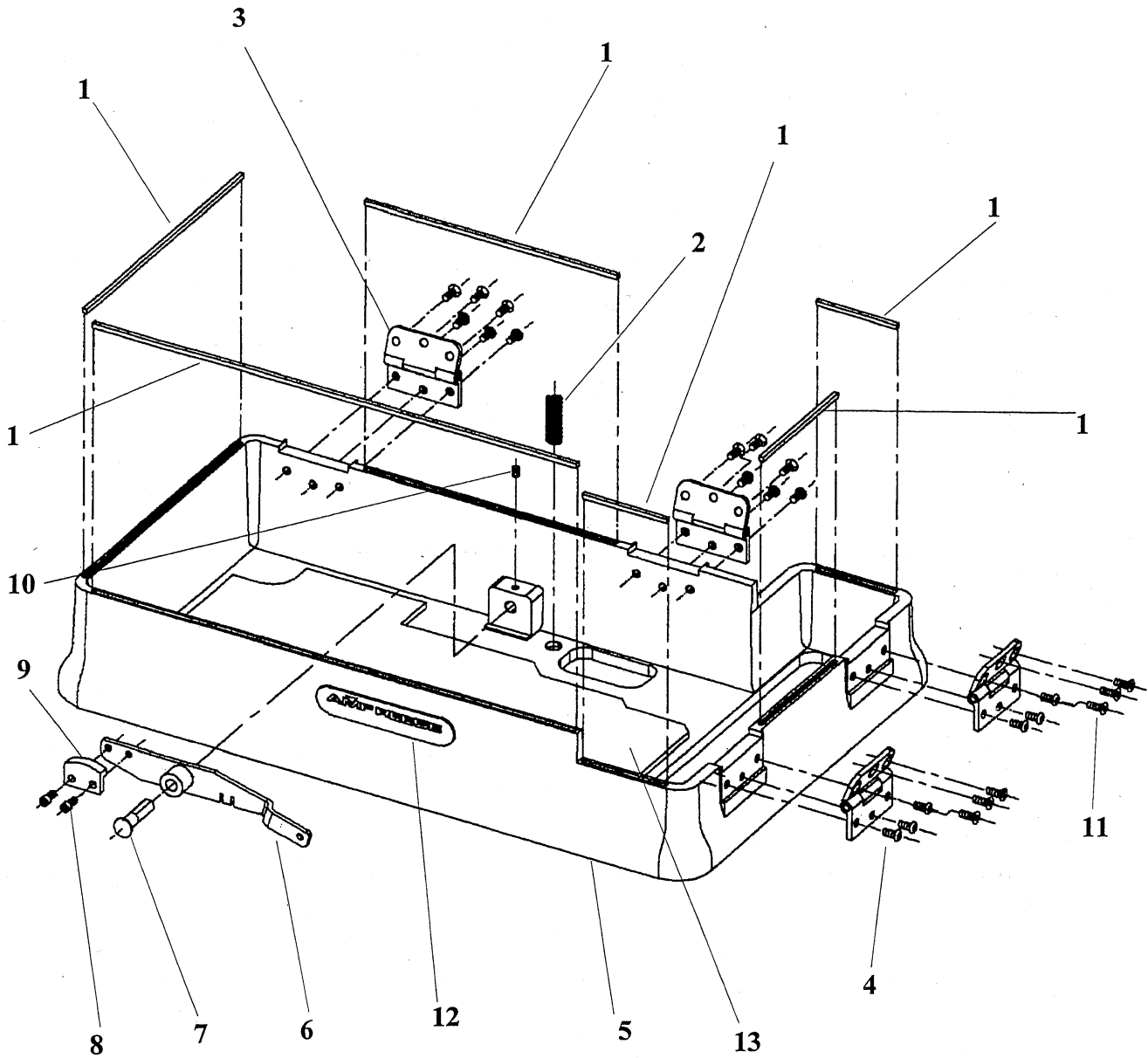

BASE

DET	PART NUMBER	DESCRIPTION
01	22.0038.0.000	Base Gasket
02	07.6440.0.039	Spring
03	22.1010.0.000	Base Hinge
04	08.6200.5.012	M5 x 12 Button Head Screw
05	22.6005.0.000	Base
06	22.0051.0.000	Engaging Lever
07	22.6266.0.000	Stop Pin
08	08.6000.4.008	M4 x 8 Cap Screw
09	22.0088.0.000	Engaging Lever End
10	08.6400.5.008	M5 x 8 Set Screw
11	08.6100.5.012	M5 x 12 FH Screw
12	05.1391.0.000	Logo Plate
13	22.0111.0.000	Base Sound Deadener

Revised 2/97

U.S. Phone (800) 237-3323 Fax (800) 432-4303

Outside U.S. Phone (804) 559-5000 Fax (804) 559-5290

BITE MECHANISM

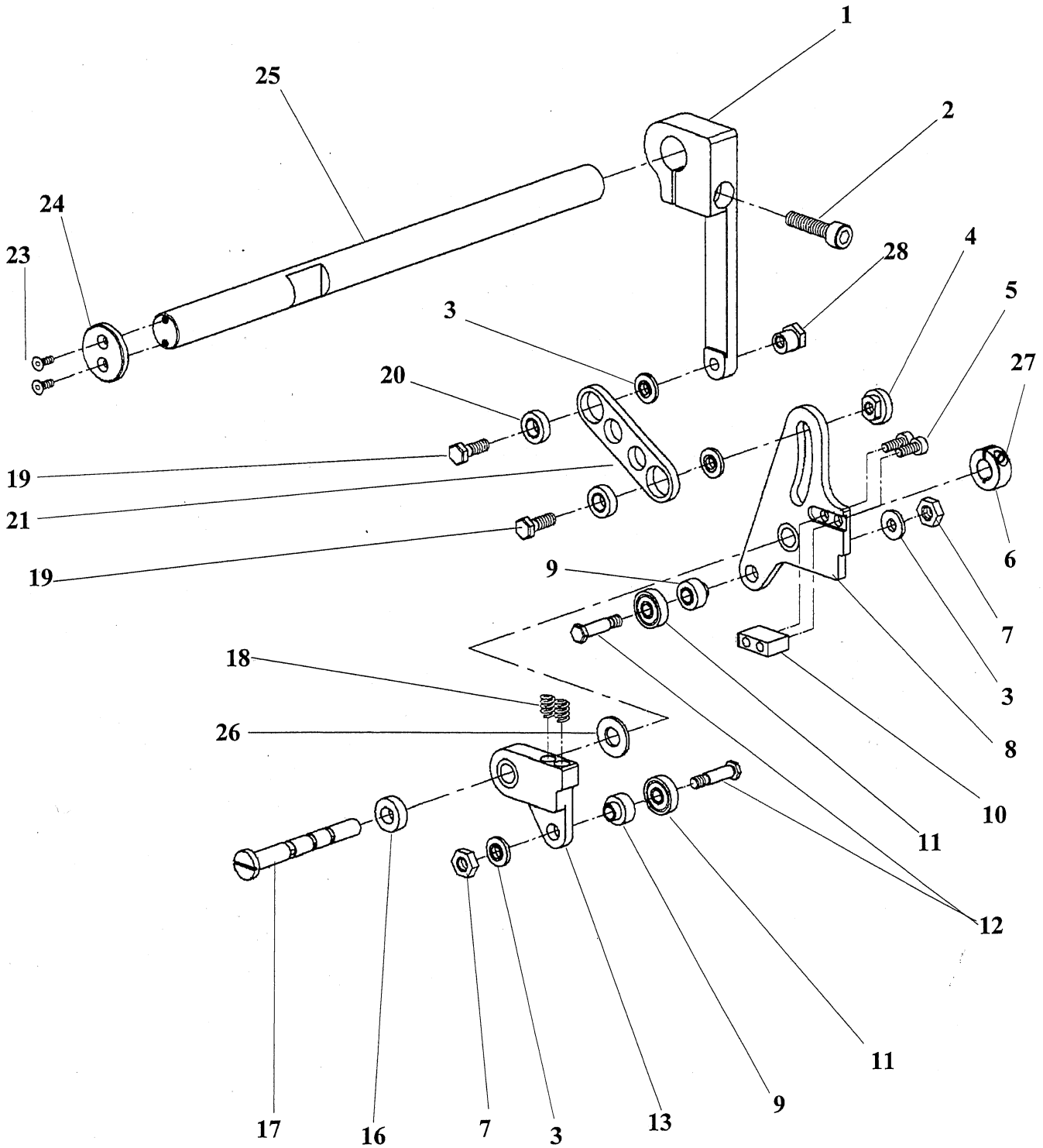

BITE MECHANISM

DET	PART NUMBER	DESCRIPTION
01	22.0008.0.000	Bite Lever
02	08.6000.6.025	M6 x 25 Screw
03	22.0100.0.000	Shoulder Washer
04	22.0110.0.000	M5 Shoulder Nut
05	08.6000.4.014	M4 x 14 Screw
06	22.0183.0.000	Collar*Dia. 8
07	08.6700.5.000	M5 Hex Nut
08	22.0033.0.000	Left Cam Follower
09	22.0029.0.000	Bite Follower Bearing Spacer
10	22.0030.0.000	Bite Follower Spring Retainer
11	07.6321.0.025	Bearing
12	22.0028.0.000	Bite Follower Bearing Screw
13	22.0027.0.000	Right Cam Follower
16	22.0069.0.000	Bite Follower Spacer
17	22.0020.0.000	Bite Pivot Shaft
18	07.6440.0.028	Compression Spring
19	22.0064.0.000	Bite Shoulder Screw
20	07.6321.0.029	Bearing
21	22.0009.0.000	Bite Adjusting Link
23	08.6100.3.008	M3 x 8 FH Screw
24	22.0063.0.000	Bite Shaft Retainer
25	22.0005.0.000	Bite Shaft
26	01.4980.0.000	8mm ID Flat Washer
27	08.6000.3.010	M3 x 10 Screw
28	22.0214.0.000	M5 Eccentric Nut

Revised 2/98

U.S. Phone (800) 237-3323 Fax (800) 432-4303

Outside U.S. Phone (804) 559-5000 Fax (804) 559-5290

CLUTCH MECHANISM

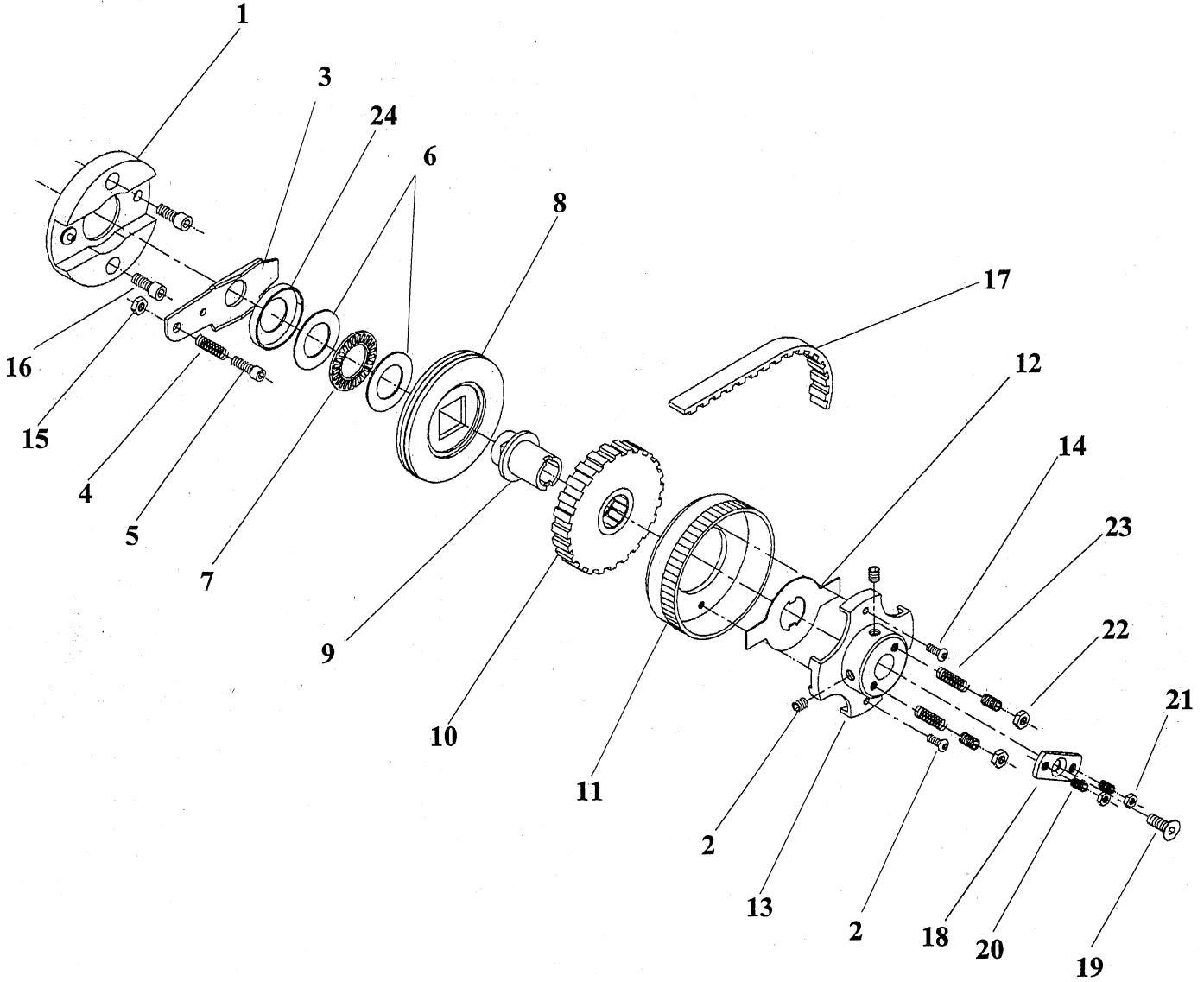

CLUTCH MECHANISM

DET	PART NUMBER	DESCRIPTION
01	22.0225.0.000	Hinge Block Assembly
02	08.6400.6.010	M6 x 10 Screw
03	22.0235.0.000	Clutch Switch Spring
04	07.6440.0.032	Spring
05	08.6000.5.025	M5 x 25 Screw
06	07.6321.0.003	Thrust Washer
07	07.6321.0.006	Thrust Bearing
08	22.0210.0.050	Disk Assembly
09	22.0220.0.000	Switch Bushing
10	22.0060.0.000	Timing Pulley / Clutch
11	22.0200.0.050	Handwheel Assembly
12	22.0215.0.000	Brake Spring
13	22.0205.0.000	Hand Wheel Disk
14	08.6200.4.010	M4 x 10 Screw
15	08.6700.5.000	M5 Nut
16	08.6000.6.012	M6 x 12 Set Screw
17	07.6243.0.000	Belt T10/370
18	22.0280.0.000	Plate Retainer
19	08.6100.6.012	M6 x 12 Screw
20	08.6400.5.008	M5 x 8 Screw
21	08.6700.5.000	M5 Nut
22	08.6710.6.000	M6 Nut
23	07.6440.0.043	Spring
24	22.0163.0.000	Cup Washer

Revised 2/98

U.S. Phone (800) 237-3323 Fax (800) 432-4303

Outside U.S. Phone (804) 559-5000 Fax (804) 559-5290

KNIFE MECHANISM

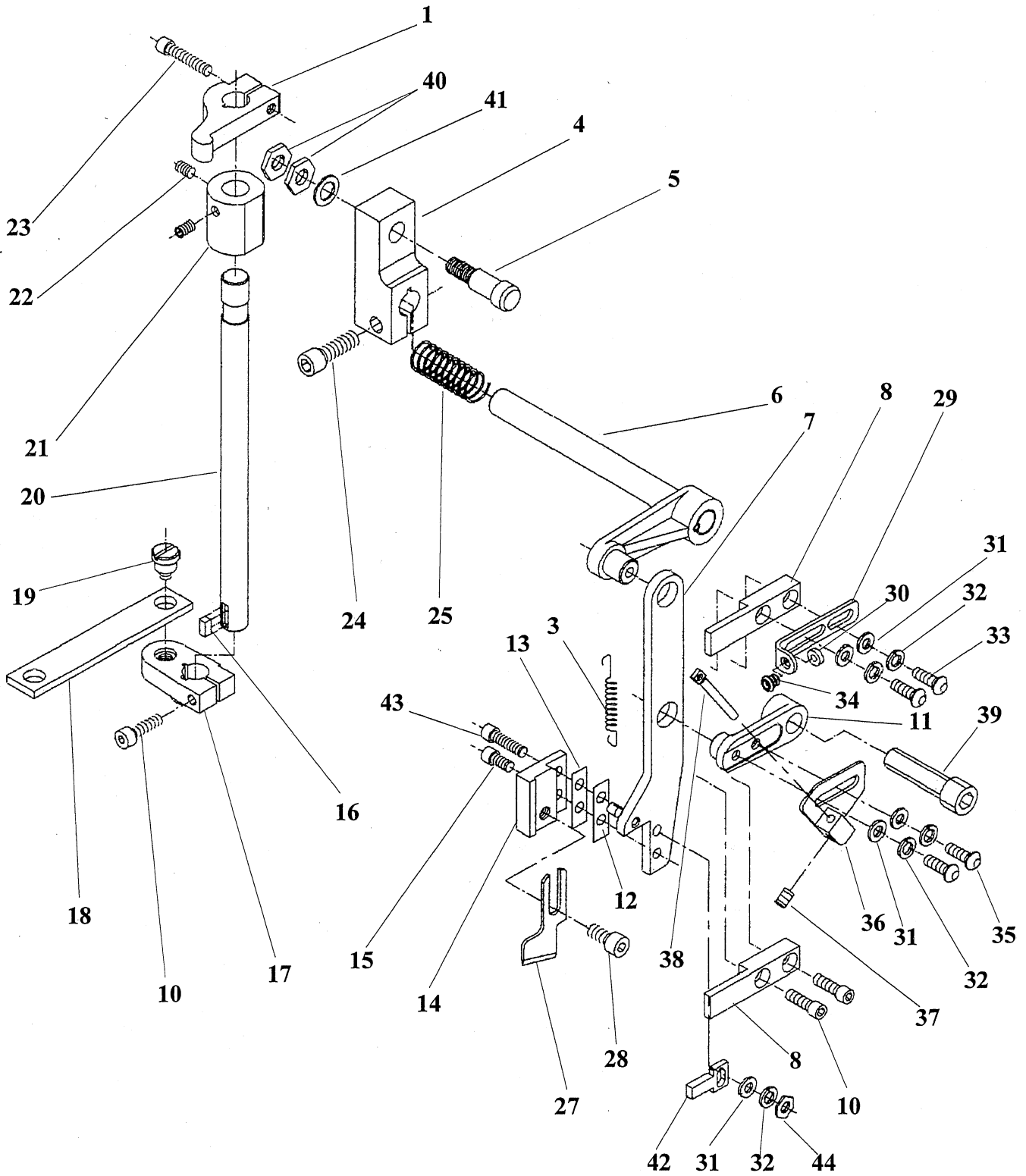

KNIFE MECHANISM

DET	PART NUMBER	DESCRIPTION
01	22.0042.0.000	Engaging Lever
03	07.6440.0.035	Spring
04	22.1405.0.000	Knife Cam Follower Lever
05	22.1406.0.000	Knife Cam Follower Stud Pin
06	22.1415.0.050	Knife Lever Assembly
07	22.1430.0.000	Knife Holder
08	22.1436.0.000	Knife Cover Cross Bar
10	08.6000.4.016	M4 x 16 Screw
11	22.1416.0.000	Knife Guide Link
12	22.1442.0.000	Knife Shim .10mm
13	22.1443.0.000	Knife Shim .05mm
14	22.1426.0.000	Knife Holder Shim Block
15	08.6200.4.006	M4 x 6 Screw
16	22.0188.0.000	Key 3x3x6
17	22.0035.0.000	Knife Barring Clamp
18	22.0034.0.000	Knife Barring Link
19	22.0066.0.000	Knife Link Should Screw
20	22.0041.0.000	Pivot Shaft Cutting Mechanism
21	22.0040.0.000	Cam Barring Tension Release
22	08.6400.4.005	M4 x 5 Screw
23	08.6000.4.020	M4 x 20 Screw
24	08.6000.6.018	M6 x 18 Screw
25	07.6440.0.034	Spring
27	See Accessories	Knife
28	08.6000.5.008	M5 x 8 Soc.Hd.Cap Screw
29	22.0046.0.000	Thread Guide Bracket
30	01.6551.0.000	Retaining Ring
31	08.6850.4.000	M4 Flat Washer
32	08.6800.4.000	M4 Lockwasher
33	08.6200.4.016	M4 x 16 BH Cap Screw
34	01.7447.1.000	Porcelain Guide
35	08.6200.4.010	M4 x 10 BH Cap Screw
36	22.0094.0.000	Thread Draw Off
37	08.6400.4.004	M4 x 4 Set Screw
38	22.0091.0.000	Thread Take-Up
39	22.0161.0.000	Pivot Pin Link
40	08.6700.5.000	M5 Nut
41	22.0211.0.000	Washer
42	22.0145.0.000	Knife Stop
43	08.6000.4.012	M4 x 12 Screw
44	08.6700.4.000	M4 Nut

Revised 2/98

U.S. Phone (800) 237-3323 Fax (800) 432-4303

Outside U.S. Phone (804) 559-5000 Fax (804) 559-5290

MAIN CAM

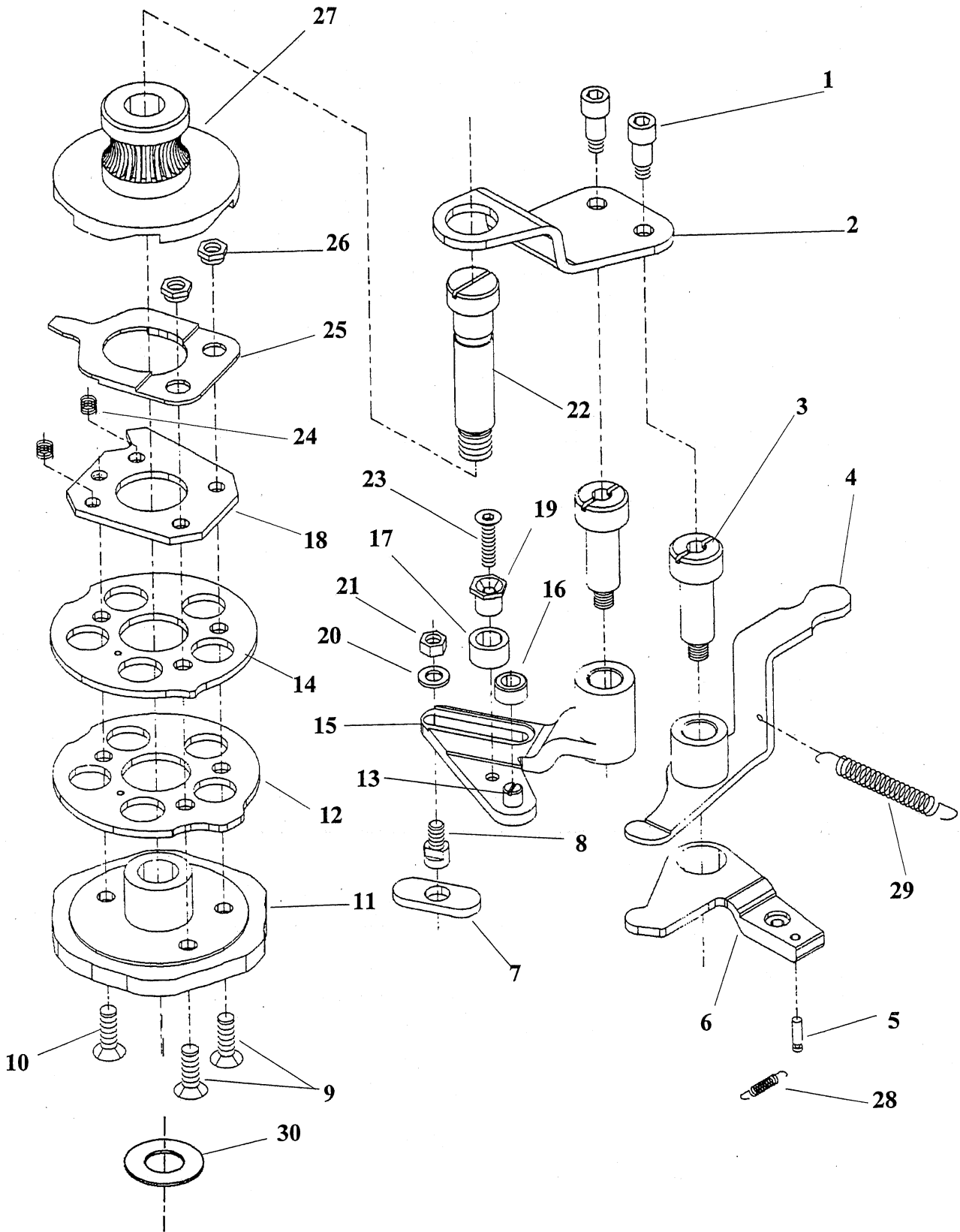

MAIN CAM

DET	PART NUMBER	DESCRIPTION
01	22.0182.0.000	M5 x 4 Screw
02	22.0097.0.000	Main Cam Brace
03	22.0106.0.000	Hub Shoulder Screw
04	22.2640.0.050	Feed Reversing Lever
05	07.6045.0.050	3x10 Pin
06	22.2645.0.000	Knife Actuating Lever
07	22.2631.0.000	Clamp Plate Slidestone
08	22.2633.0.000	Slidestone Retaining Screw
09	22.0137.0.000	M5 x 14 Screw
10	08.6100.5.010	M5 x 10 Screw
11	22.2600.0.000	Barring Cam
12	22.2622.0.000	Barring Tension Knife Cam
13	22.2637.0.000	Barring Lever Stud
14	22.2620.0.000	Feed Reversing Cam
15	22.2630.0.000	Barring Lever
16	22.2639.0.000	Barring Lever Roller
17	22.2638.0.000	Barring Lever Roller
18	22.2624.0.000	Stop Cam Disk
19	22.2635.0.000	Barring Lever Eccentric
20	08.6850.5.000	M5 Washer
21	08.6700.5.000	M5 Nut
22	22.2610.0.000	Main Cam Shoulder Screw
23	08.6100.4.012	M4 x 12 FH Screw
24	07.6440.0.037	Spring
25	22.2626.0.000	Drive Disk Switch Spring
26	22.2627.0.000	Shoulder Nut
27	22.2607.0.000	Drive Disk/Worm Gear Hub
28	07.6440.0.046	Pull Spring
29	07.6440.0.045	Extension Spring
30	07.6321.0.001	Thrust Washer

Revised 2/98

U.S. Phone (800) 237-3323 Fax (800) 432-4303

Outside U.S. Phone (804) 559-5000 Fax (804) 559-5290

HEAD

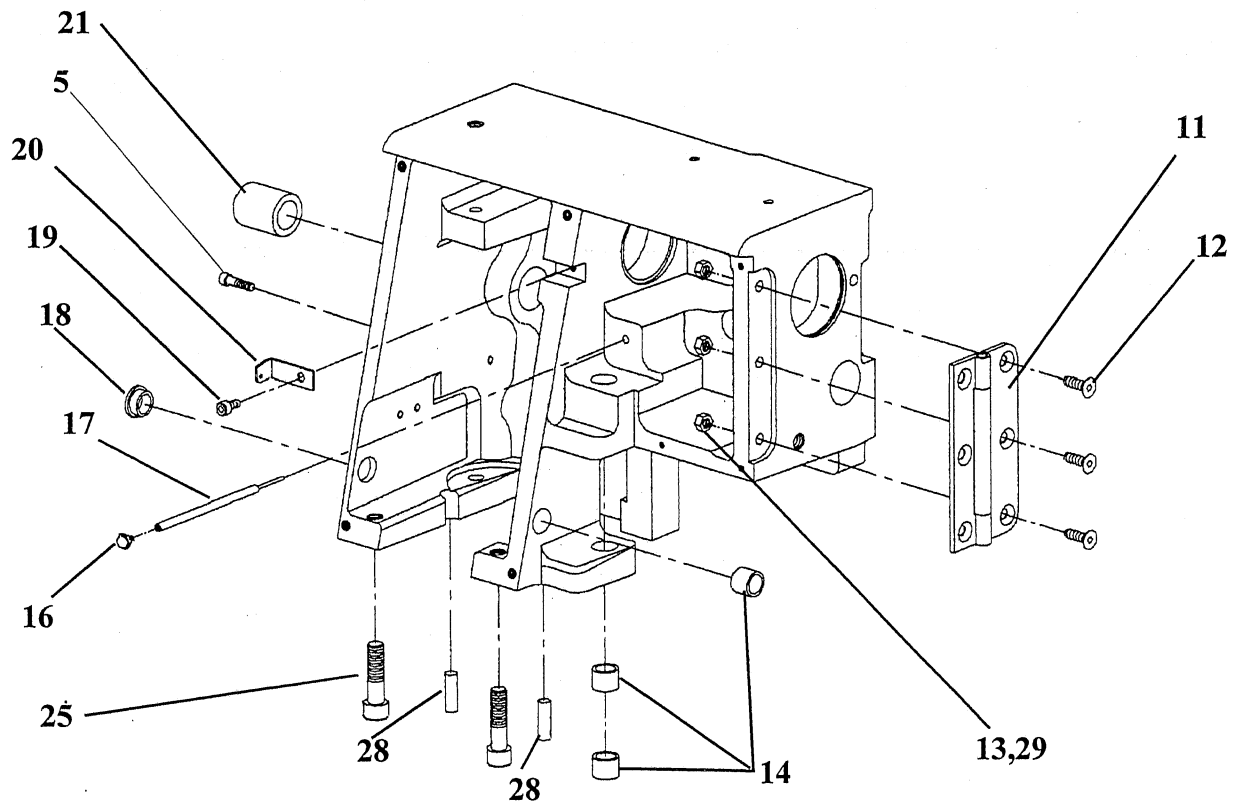
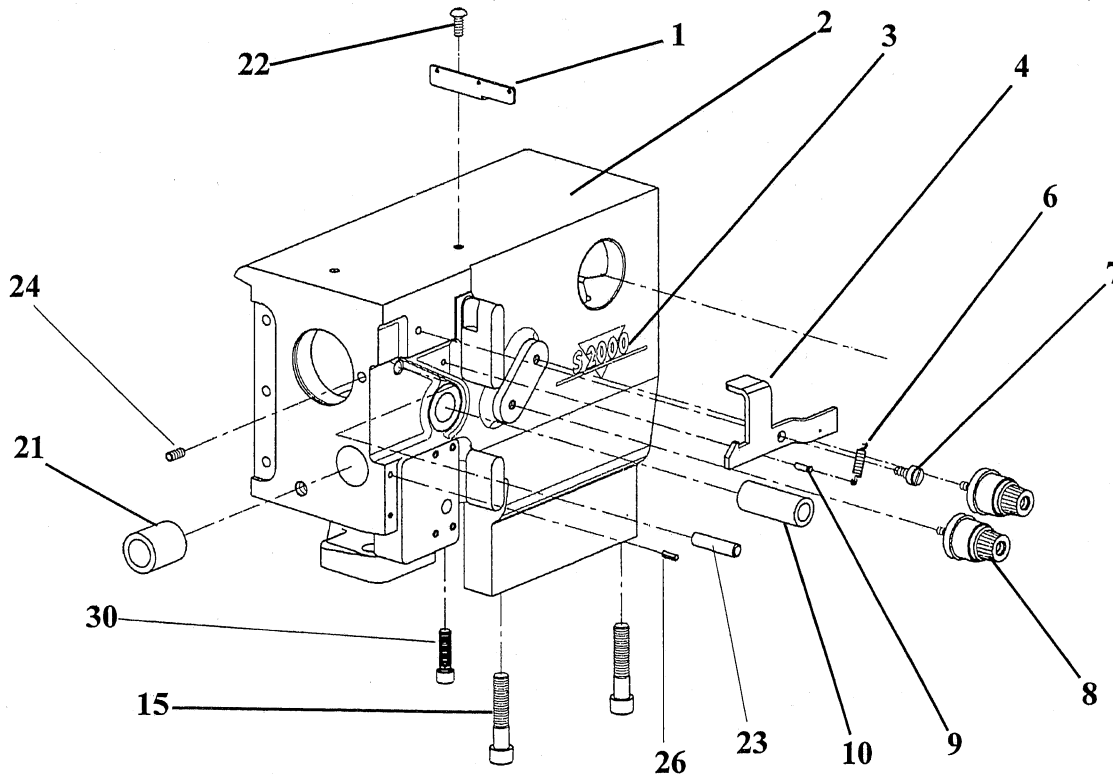

HEAD

DET	PART NUMBER	DESCRIPTION
01	22.0054.0.000	Upper Thread Guide
02	22.6000.0.000	Head
03	05.4113.0.000	S-2000 Decal
04	22.0058.0.000	Sewing Head Latch
05	22.0124.0.000	Screw
06	07.6440.0.051	Latch Tension Spring
07	22.0062.0.000	M4 x 3 Dia.6 Screw
08	23.2044.0.050	Large Tension Assembly
09	07.6045.0.037	3x16 Grooved Pin
10	22.1422.0.000	Knife Shaft Bushing
11	22.6002.0.000	Head Hinge Assembly
12	08.6100.5.020	M5 x 20 Screw
13	08.6700.5.000	M5 Hex Nut
14	01.7147.0.000	10-13 x 10 Oilite Bushing
15	08.6000.8.040	M8 x 40 Screw
16	22.0053.0.000	Tension Release Button
17	22.0052.0.000	Tension Release Shaft
18	01.7149.0.000	10-13 x 6 FL Oilite Bushing
19	08.6000.4.008	M4 x 8 Screw
20	22.0055.0.000	Spring Anchor
21	01.7806.0.000	15-22 x 25 Oilite Bushing
22	08.6200.5.008	M5 x 8 Screw
23	07.6045.0.053	6 x 20 Pin
24	08.6400.5.010	M5 x 10 Screw
25	08.6000.8.025	M8 x 25 Screw
26	12.1015.0.001	4x16 Pin
28	12.1011.0.001	6x20 Pin
29	08.6850.5.000	M5 Flat Washer
30	08.6000.5.016	M5 x 16 Screw

Revised 2/98

U.S. Phone (800) 237-3323 Fax (800) 432-4303

Outside U.S. Phone (804) 559-5000 Fax (804) 559-5290

BEDPLATE

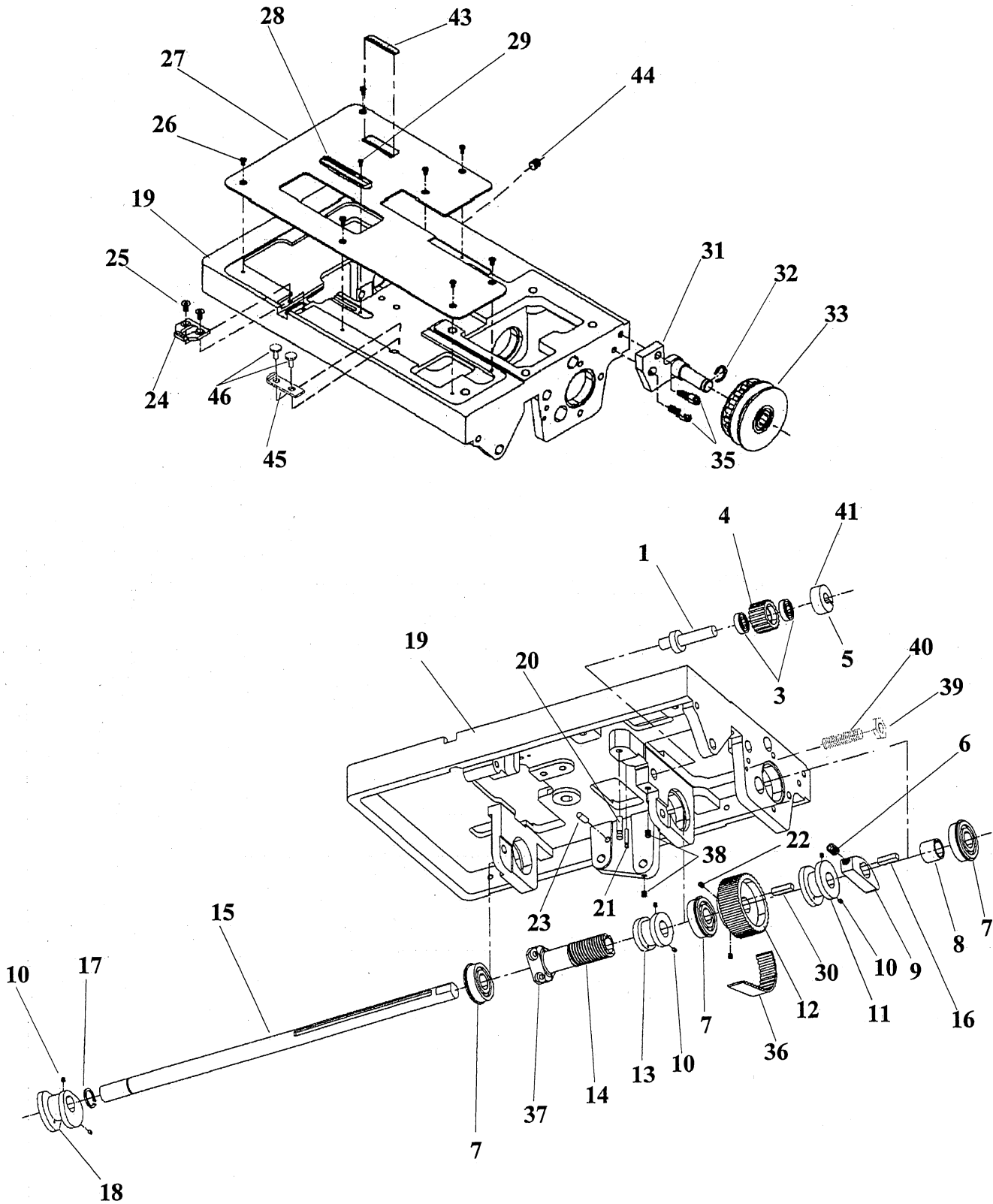

BEDPLATE

DET	PART NUMBER	DESCRIPTION
01	22.8201.0.000	Idler Pulley Eccentric Shaft
03	01.7622.0.000	Bearing
04	22.8205.0.000	Idler Pulley
05	22.0191.0.000	Collar*Dia. 10
06	08.6400.8.008	M8 x 8 Set Screw
07	01.7805.0.000	Top Shaft Bearing w/Snap Ring
08	22.6201.0.000	Stop Cam Spacer
09	22.6203.0.000	Stop Cam
10	08.6400.5.305	M5 x 0.5-5 Screw
11	22.0006.0.000	Bite Cam
12	22.8210.0.000	Main Shaft Drive Pulley
13	22.0300.0.000	Feed Cam
14	22.8400.0.000	Shaft Worm Gear
15	22.1000.0.000	Main Shaft
16	22.0189.0.000	Key*5x5x12
17	12.1045.2.001	Retaining Ring*Dia.1.5
18	22.2400.0.000	Looper Cam
19	22.6100.0.000	Bedplate
20	07.6045.0.054	5 x 20mm Spring Pin
21	07.6045.0.037	3 x 16mm Spring Pin
22	03.6400.5.010	M5 x 10 Set Screw
23	22.0154.0.000	Pin
24	22.0408.0.000	Trimmer Cover Plate
25	08.6100.4.006	M4 x 6 FH Screw
26	08.6200.3.008	M3 x 8 Button Hd. Screw
27	22.6101.0.000	Cover Plate
28	20.0051.1.024	Throat Plate
29	01.2084.0.000	6-52 Fil. Screw
30	22.0190.0.000	Key*5x5x20
31	22.0065.0.000	Jackshaft Assembly
32	07.6045.0.034	E-Clip*Dia. 9
33	22.0078.0.050	Drive Pulley Assembly
35	08.6000.6.020	M6 x 20 Soc.Hd. Cap Screw
36	07.6242.0.000	Belt
37	22.0153.0.000	Screw
38	08.6400.5.008	M5 x 8 Set Screw
39	08.6700.4.000	M4 Nut
40	08.6400.4.020	M4 x 20 Screw
41	08.6400.4.004	M4 x 4 Screw
43	22.0096.0.000	Buttonhole Size Sticker
44	08.6400.4.006	M4 x 6 Screw
45	22.0115.0.000	Stop
46	22.0143.0.000	Screw

Revised 2/98

U.S. Phone (800) 237-3323 Fax (800) 432-4303

Outside U.S. Phone (804) 559-5000 Fax (804) 559-5290

COVERS

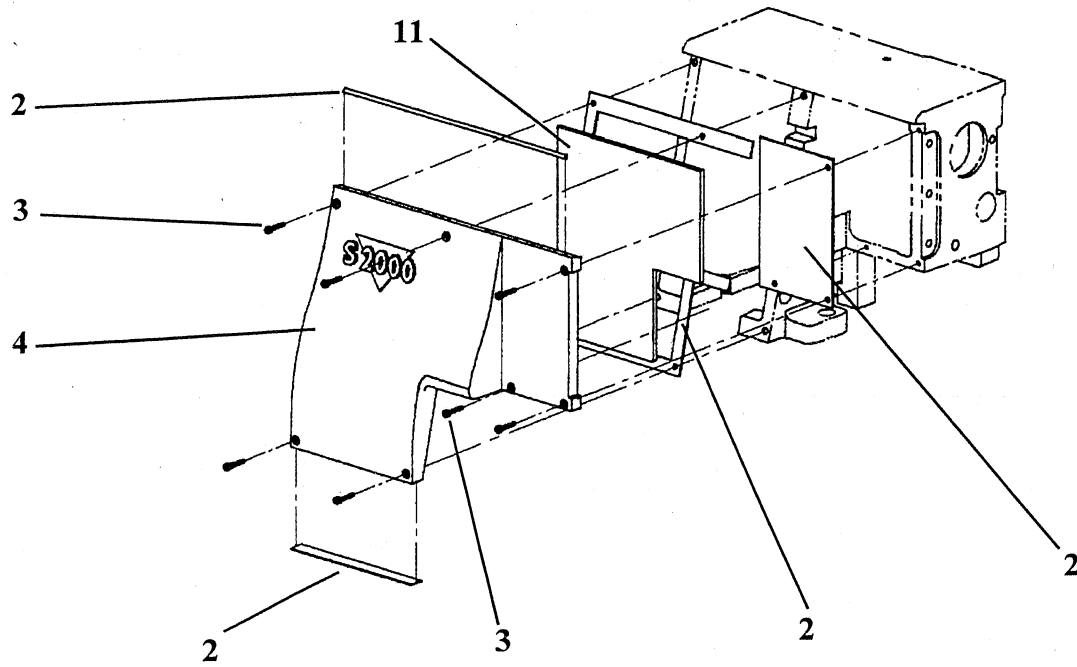
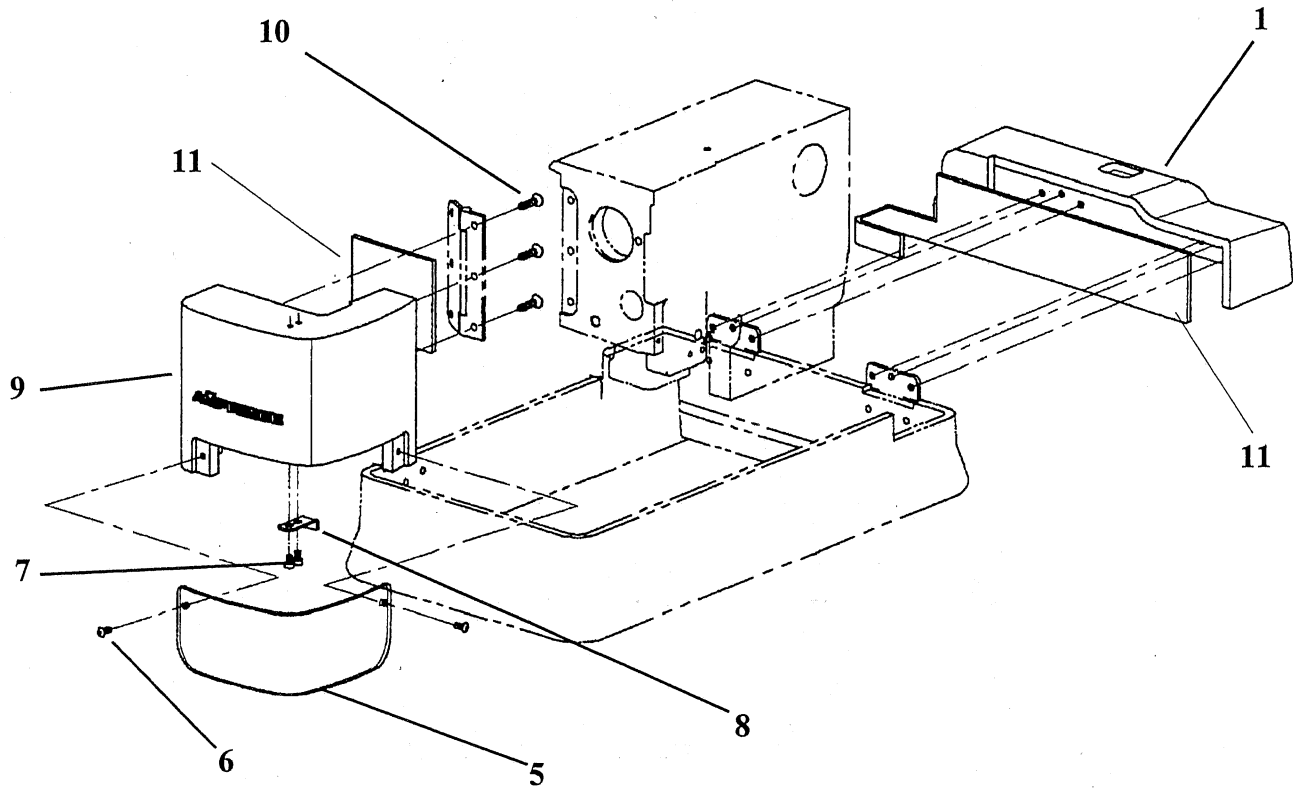

COVERS

DET	PART NUMBER	DESCRIPTION
01	22.6004.0.000	Pulley Cover
02	22.0037.0.000	Head Cover Gasket
03	08.6000.3.016	M3 x 16 Screw
04	22.6001.0.000	Head Cover
05	22.0119.0.000	Eye Shield
06	08.6200.4.008	M4 x 8 Screw
07	08.6000.4.006	M4 x 6 Screw
08	22.0057.0.000	Cover Latch
09	22.6003.0.000	Needle Bar Cover
10	08.6100.5.012	M5 x 12 Screw
11	22.0112.0.000	Cover Sound Deadener

Revised 2/97

U.S. Phone (800) 237-3323 Fax (800) 432-4303

Outside U.S. Phone (804) 559-5000 Fax (804) 559-5290

PARALLEL TABLE

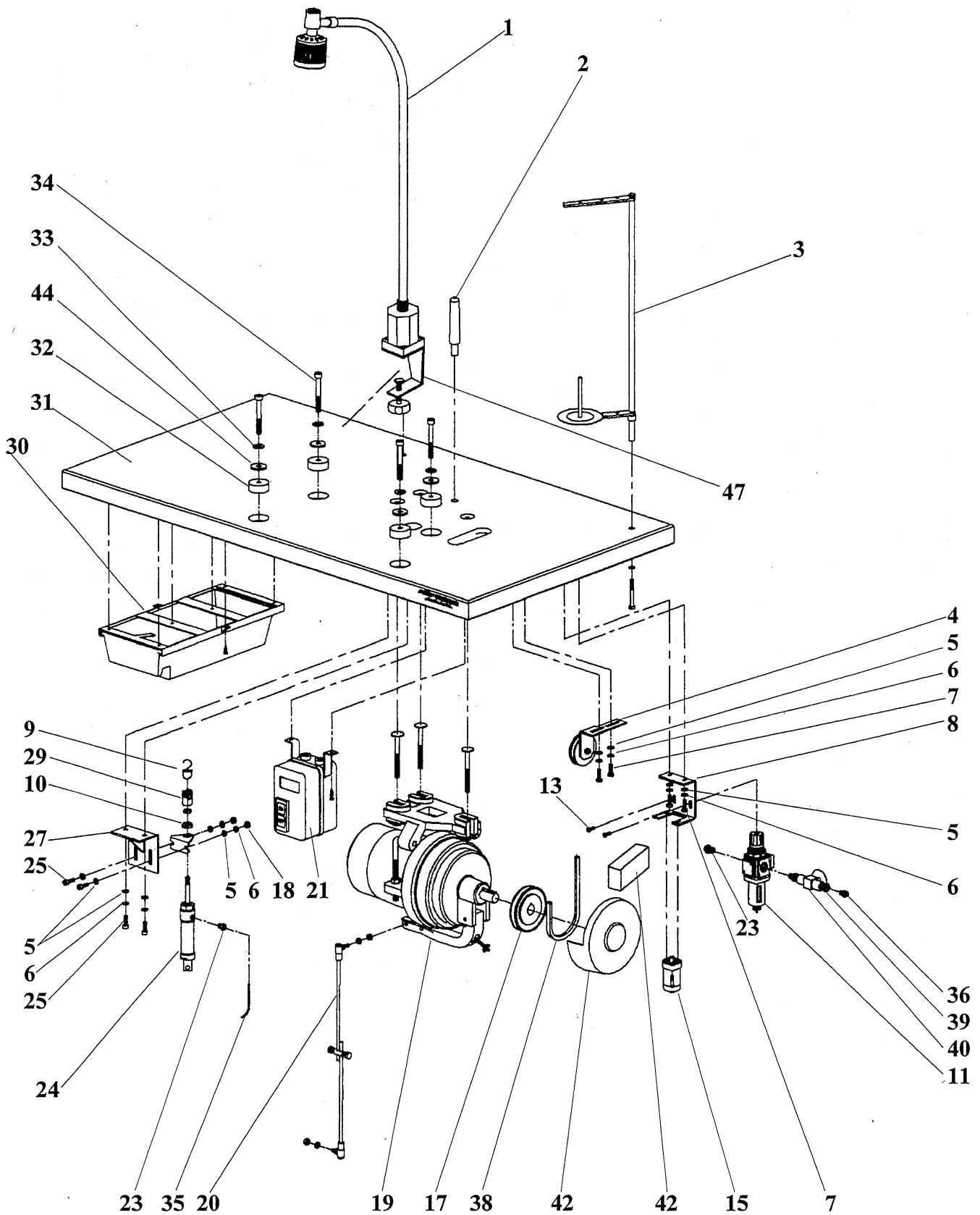

PARALLEL TABLE

DET	PART NUMBER	DESCRIPTION
01	12.0008.4.500	Halogen Lamp Kit 12V
02	12.0008.6.900	Machine Rest Table Pin
03	22.0219.0.000	Thread Stand
04	22.0090.0.050	Idler Assembly
05	08.6850.6.000	M6 Flat Washer
06	08.6800.6.000	M6 Lock Washer
07	08.6000.6.020	M6 x 20 Hex Hd. Bolt
08	22.0204.0.000	Regulator/Delay Valve Bracket
09	22.0000.0.078	Chain Hook
10	12.0008.6.902	Rubber Cushion
11	12.0008.3.075	Filter/Regulator
13	08.6100.4.006	M4 x 6 Screw
15	12.0008.3.085	Valve
17	22.0206.0.000	50 Cycle V-Drive Pulley
	22.0207.0.000	60 Cycle V-Drive Pulley
18	08.6700.6.000	M6 Hex Nut
19	17.0007.8.173	Motor, 550W 220/380V 50/60 Hz 3Ph/1Ph
	17.0007.8.171	Motor, 550W 115V/60Hz 1 Phase
	17.0007.8.172	Motor, 550W 230V/50Hz 1 Phase
20	04.1956.0.000	Pitman Rod-Ball Joint Assembly
21	22.1973.0.000	Motor Starter, 110V 1 Phase
	22.1974.0.000	Motor Starter, 230V 3 Phase
	22.1974.0.001	Motor Starter, 230V 1 Phase
	22.1974.0.002	Motor Starter, 380V 3 Phase
23	12.0008.3.089	Reducer
24	12.0008.3.086	Air Cylinder
25	08.6000.6.020	M6 x 20 Cap Screw
27	22.0198.0.000	Air Cylinder Bracket
29	12.0008.3.087	Clevis
30	12.0008.6.901	Drawer
31	22.0070.0.000	S-2000 Parallel Table Top 1100 x 600
32	17.0095.1.273	Rubber Mount
33	08.6870.0.001	Washer
34	08.6000.8.055	Bolt
35	12.0008.3.093	Tubing
36	12.0008.3.092	Reducer
38	12.5050.1.001	V-Belt 60 Hz
	12.5050.1.002	V-Belt 50 Hz
39	12.0008.3.091	Joint
40	12.0008.3.083	Valve
41	12.0008.6.500	Lamp Clamp
42	22.0197.0.000	Belt Guard
43	22.0128.0.000	Metal Belt Guard
44	17.0095.1.272	Washer

Revised 2/98

U.S. Phone (800) 237-3323 Fax (800) 432-4303

Outside U.S. Phone (804) 559-5000 Fax (804) 559-5290

PARALLEL TABLE

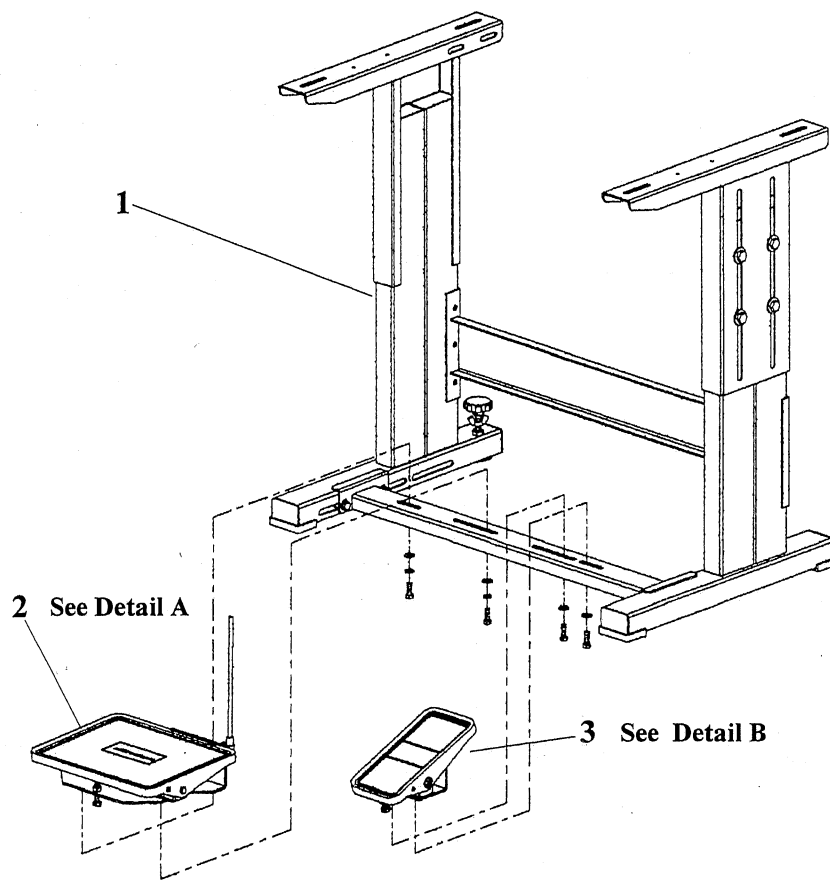

Detail A

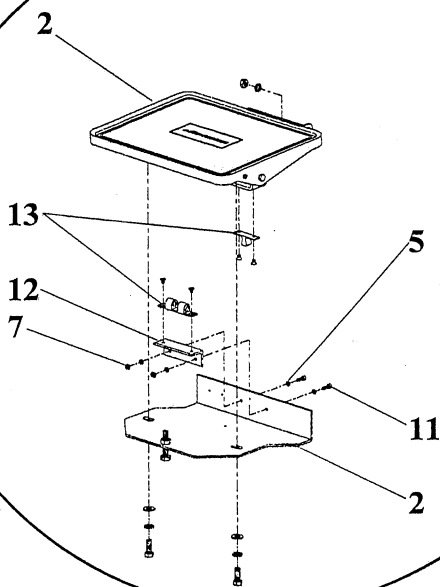

Detail B

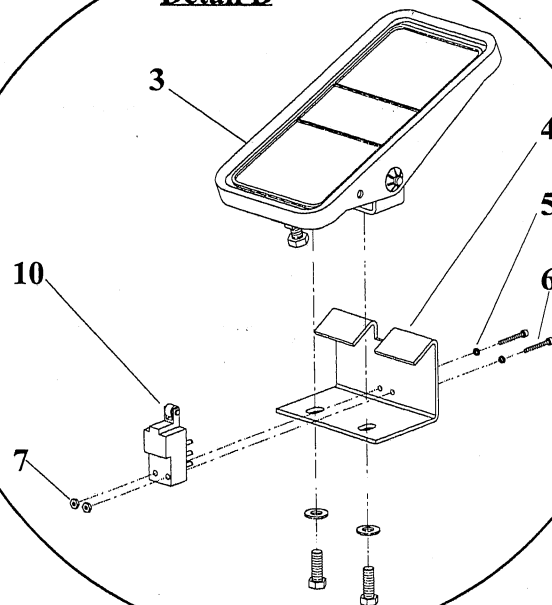

PARALLEL TABLE

DET	PART NUMBER	DESCRIPTION
01	12.0008.6.501	Frame Kit
02	22.0218.0.000	Footswitch Assembly
03	12.0008.6.503	Small Foot Pedal Assembly
04	22.0203.0.000	Air Start Foot Treadle Bracket
06	08.6000.4.025	M4 x 25 Screw
07	08.6700.3.000	M3 Hex Nut
10	12.0008.3.084	Microswitch
11	08.6000.3.012	M3 x 12 Screw
12	22.0216.0.000	Latch Bracket
13	04.9000.0.802	Tension Latch

Revised 2/98

U.S. Phone (800) 237-3323 Fax (800) 432-4303

Outside U.S. Phone (804) 559-5000 Fax (804) 559-5290

3-35

CROSSWISE TABLE

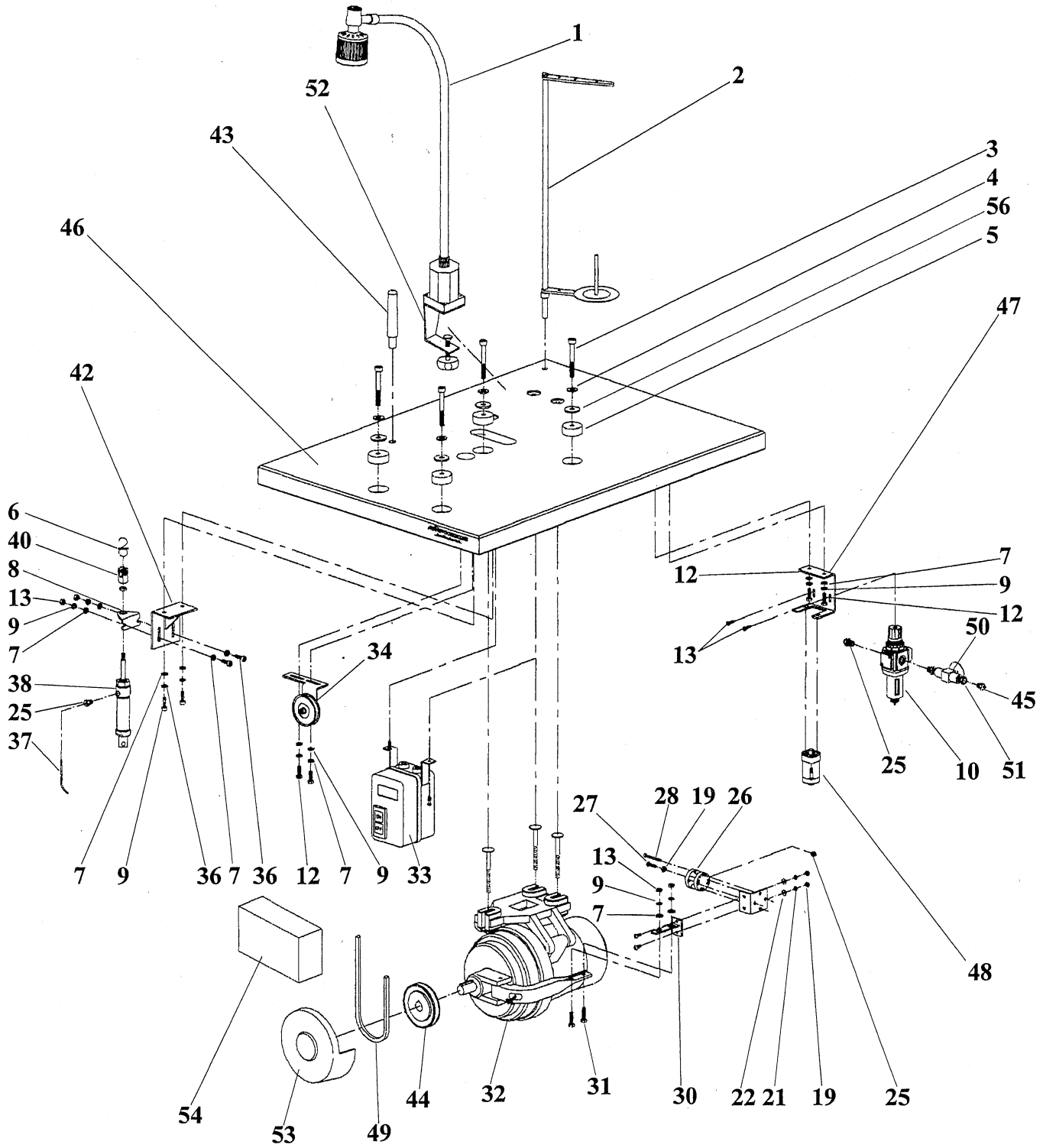

CROSSWISE TABLE

DET	PART NUMBER	DESCRIPTION	DET	PART NUMBER	DESCRIPTION
01	12.0008.4.500	Halogen Lamp Kit 12V	33	22.1973.0.010	Motor Starter 110V 1 Phase
02	22.0219.0.000	Thread Stand		22.1974.0.010	Motor Starter 230V 3 Phase
03	08.6000.8.055	Bolt		22.1974.0.011	Motor Starter 230V 1 Phase
04	08.6870.0.001	Washer		22.1974.0.012	Motor Starter 380V 3 Phase
05	17.0095.1.273	Rubber Mount	34	22.0090.0.050	Idler Assembly
06	22.0000.0.078	Chain Hook	36	08.6000.6.020	M6 x 20 Cap Screw
07	08.6850.6.000	M6 Flat Washer	37	12.0008.3.013	Tubing
08	12.0008.6.902	Rubber Pad	38	12.0008.3.086	Air Cylinder
09	08.6800.6.000	M6 Lockwasher	40	12.0008.3.087	Clevis
10	12.0008.3.075	Filter/Regulator	42	22.0008.0.000	Air Cylinder Bracket
12	08.6000.6.020	M6 x 20 Hex Head Bolt	43	12.0008.6.900	Machine Rest Table Pin
13	08.6100.4.006	M4 x 6 Screw	44	22.0206.0.000	50 Cycle V-Drive Pulley
19	08.6702.5.000	M5 Hex Nut		22.0207.0.000	60 Cycle V-Drive Pulley
21	08.6802.5.000	M5 Lockwasher	45	12.0008.3.092	Reducer
22	08.6852.5.000	M5 Flat Washer	46	22.0098.0.000	S-2000 Crosswise Table Top $\phi 40 \times 600$
25	12.0008.3.089	Reducer	47	22.0204.0.000	Regulator/Delay Valve Bracket
26	12.0008.3.094	Air Cylinder	48	12.0008.3.085	Valve
27	22.0147.0.000	M5 x 40 Cap Screw	49	12.5050.1.000	V-Belt 50 Hz
28	08.6200.5.060	M5 x 60 Button Head Screw		12.5050.1.001	V-Belt 60 Hz
30	22.0148.0.000	Motor Air Start Bracket	50	12.0008.3.083	Valve
31	08.6302.6.025	M6 x 25 Hex Head Bolt	51	12.0008.3.097	Joint
32	17.0007.8.173	Motor 550W 220/380V 50/60Hz 1Ph	52	12.0008.6.500	Lamp Clamp
	17.0007.8.171	Motor 550W 115V 60Hz 1Ph	53	22.0197.0.000	Belt Guard
	17.0007.8.172	Motor 550W 230V 50Hz 1Ph	54	22.0194.0.000	Metal Belt Guard
			55	12.0008.6.901	Drawer (not shown)
			56	17.0095.1.272	Washer

Revised 2/98

U.S. Phone (800) 237-3323 Fax (800) 432-4303

Outside U.S. Phone (804) 559-5000 Fax (804) 559-5290

CROSSWISE TABLE

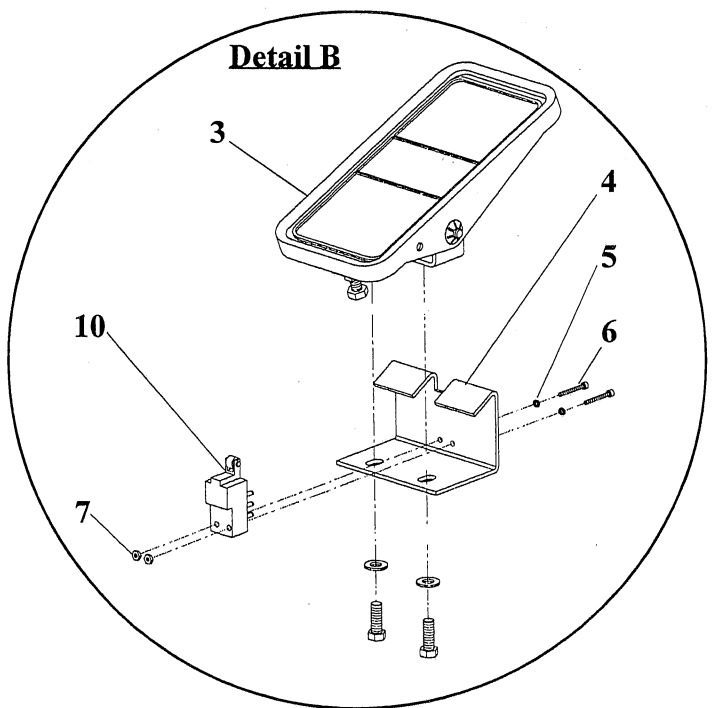
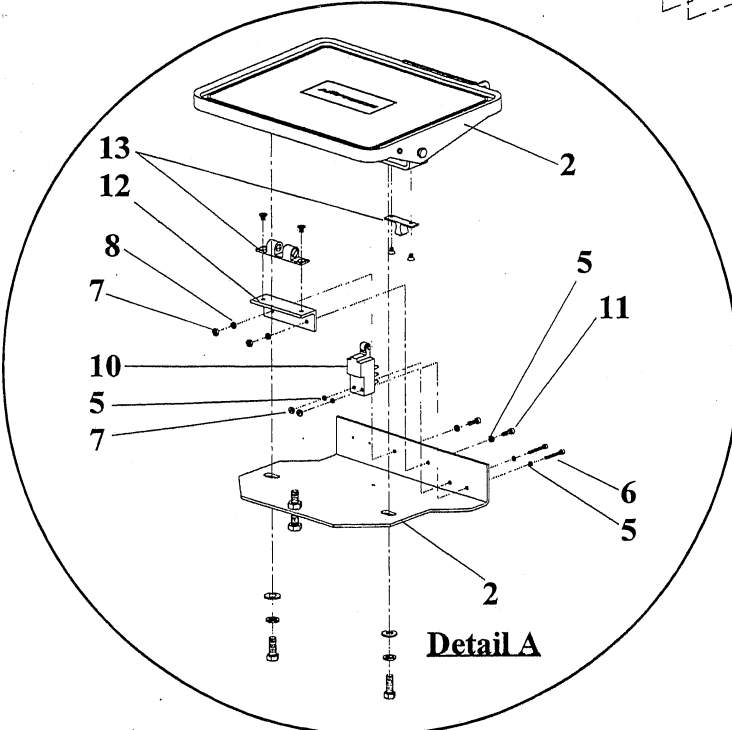
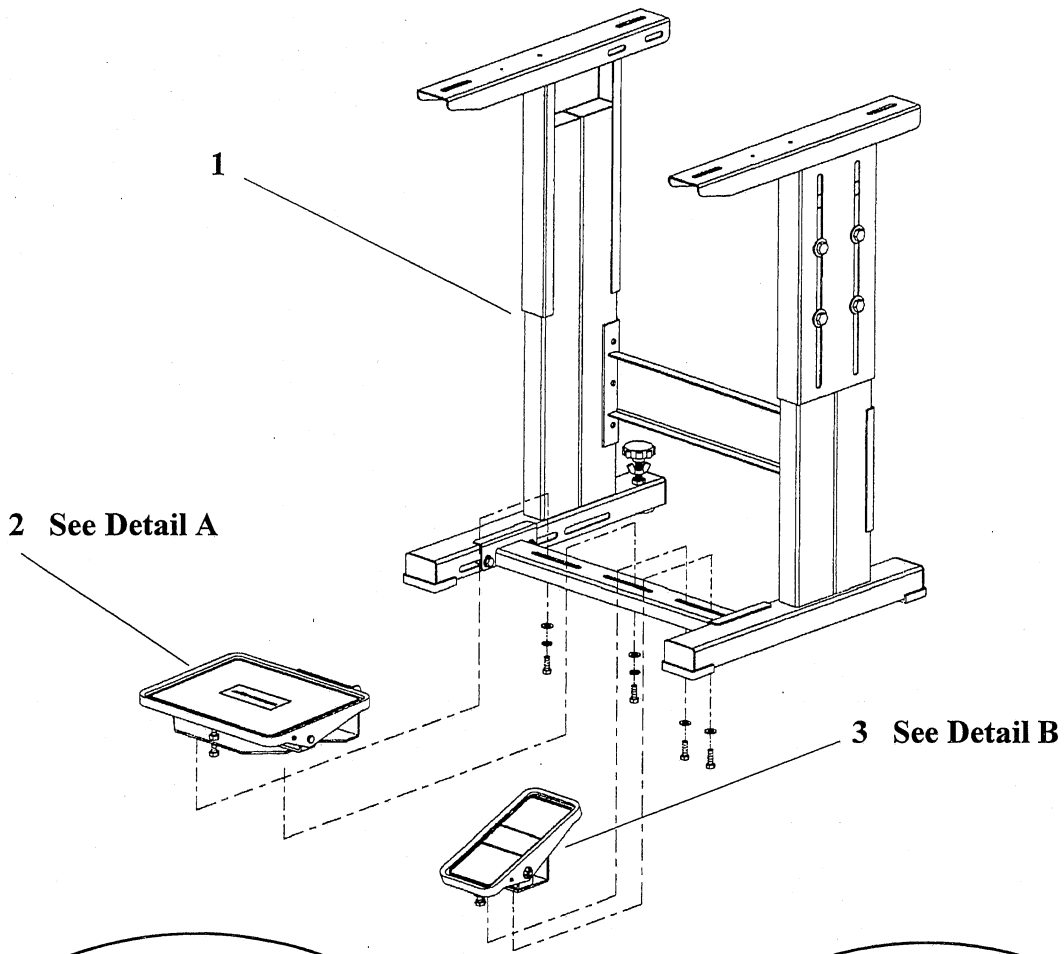

CROSSWISE TABLE

DET	PART NUMBER	DESCRIPTION
01	12.0008.6.501	Frame Kit
02	22.0218.0.000	Footswitch Assembly
03	12.0008.6.503	Small Foot Pedal Assembly
04	22.0203.0.000	Air Start Foot Treadle Bracket
05	08.6800.4.000	M4 Washer
06	08.6000.4.025	M4 x 25 Cap Screw
07	08.6700.3.000	M3 Hex Nut
08	08.6802.3.000	M3 Lockwasher
10	12.0008.3.084	Microswitch
11	08.6000.3.012	M3 x 12 Cap Screw
12	22.0216.0.000	Latch Bracket
13	04.9000.0.802	Tension Latch

Revised 2/98

U.S. Phone (800) 237-3323 Fax (800) 432-4303

Outside U.S. Phone (804) 559-5000 Fax (804) 559-5290

ACCESSORIES

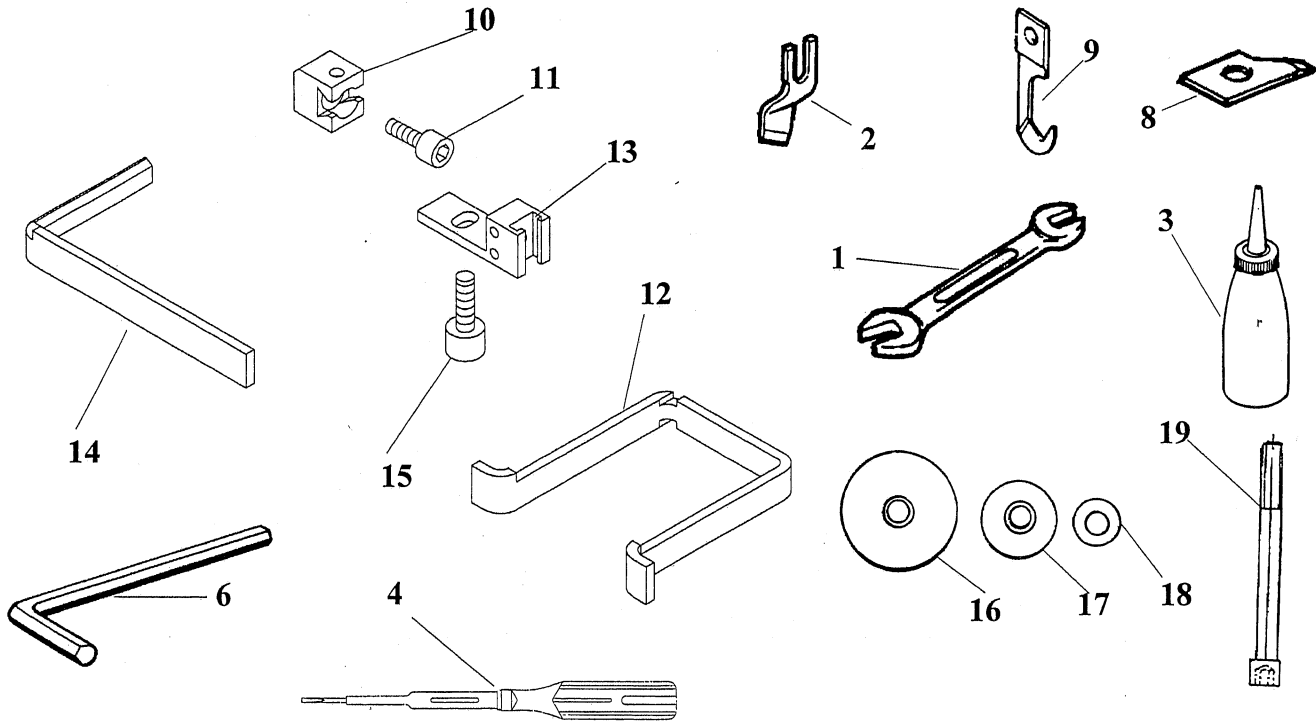

DET	PART NUMBER	DESCRIPTION
01	03.0018.0.000	Wrench
02	23.2356.2.052	13mm Knife
	23.2356.2.054	16mm Knife
	23.2356.2.055	19mm Knife
03	05.1322.0.000	Oiler
04	12.0008.6.001	Screwdriver
06	03.0197.0.000	2mm Hex Wrench
	03.0198.0.000	2-1/2mm Hex Wrench
	03.0199.0.000	3mm Hex Wrench
	03.0200.0.000	4mm Hex Wrench
07	02.0750.2.110	Needles, Size 0 (not shown)
08	20.0094.0.000	Trimmer Knife
	20.0094.1.000	Trimmer Knife*ISBH and ISBH with Indexer
09	20.0093.2.004	Trimmer Hook
10	22.0011.0.000	Parallel Gauge Block
11	08.6000.5.010	M5 x 10 Screw
12	22.0010.0.000	Crosswise Gauge
13	22.0044.0.000	Crosswise Gauge Guide
14	22.0012.0.000	Parallel Gauge
15	08.6000.4.010	M4 x 10 Screw
16	17.0095.1.273	Table Rubber Mount (4)
17	17.0095.1.272	Washer (4)
18	08.6870.8.001	Washer (4)
19	08.6000.8.055	Bolt (4)

NOTES

This page intentionally left blank.

Revised 2/98

U.S. Phone (800) 237-3323 Fax (800) 432-4303

Outside U.S. Phone (804) 559-5000 Fax (804) 559-5290

MAIN CAM - ISBH MODELS

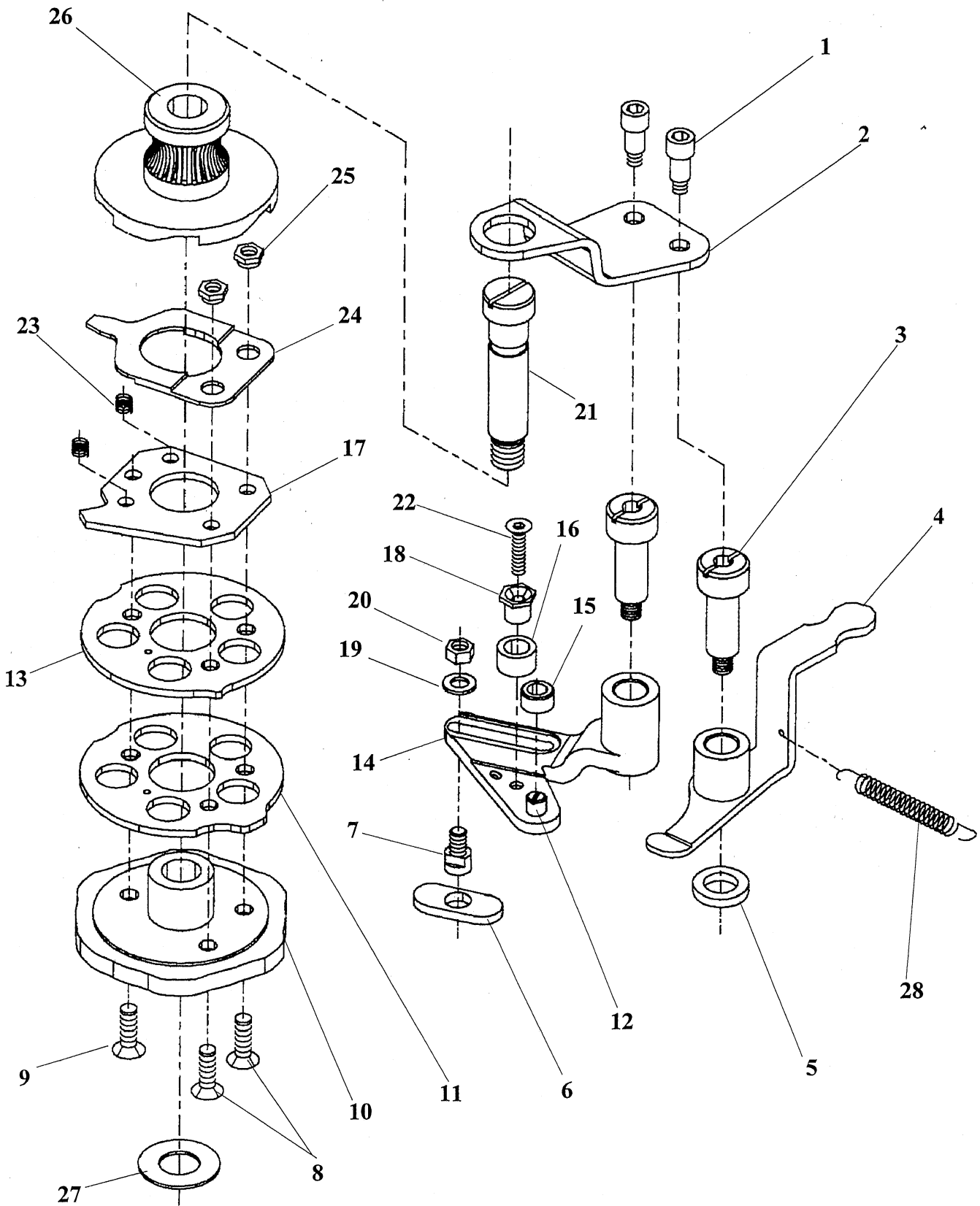

MAIN CAM - ISBH MODELS

DET	PART NUMBER	DESCRIPTION
01	22.0182.0.000	M5 x 4 Screw
02	22.0097.0.000	Main Cam Brace
03	22.0106.0.000	Hub Shoulder Screw
04	22.2640.0.050	Feed Reversing Lever
05	23.3003.0.000	Spacer
06	22.2631.0.000	Clamp Plate Slidestone
07	22.2633.0.000	Slidestone Retaining Screw
08	22.0137.0.000	M5 x 14 Screw
09	08.6100.5.010	M5 x 10 Screw
10	22.3002.0.000	Barring Cam
11	22.3001.0.000	Barring Tension Knife Cam
12	22.2637.0.000	Barring Lever Stud
13	22.3000.0.000	Feed Reversing Cam
14	22.2630.1.000	Barring Lever
15	22.2639.0.000	Barring Lever Roller
16	22.2638.0.000	Barring Lever Roller
17	22.3010.0.000	Stop Cam Disk
18	22.2635.0.000	Barring Lever Eccentric
19	08.6850.5.000	M5 Washer
20	08.6700.5.000	M5 Nut
21	22.2610.0.000	Main Cam Shoulder Screw
22	08.6100.4.012	M4 x 12 FH Screw
23	07.6440.0.037	Spring
24	22.2626.0.000	Drive Disk Switch Spring
25	22.2627.0.000	Shoulder Nut
26	22.2607.0.000	Drive Disk/Worm Gear Hub
27	07.6321.0.001	Thrust Washer
28	07.6440.0.045	Extension Spring

Revised 4/98

U.S. Phone (800) 237-3323 Fax (800) 432-4303

Outside U.S. Phone (804) 559-5000 Fax (804) 559-5290

THREAD DRAW-OFF - ISBH MODELS

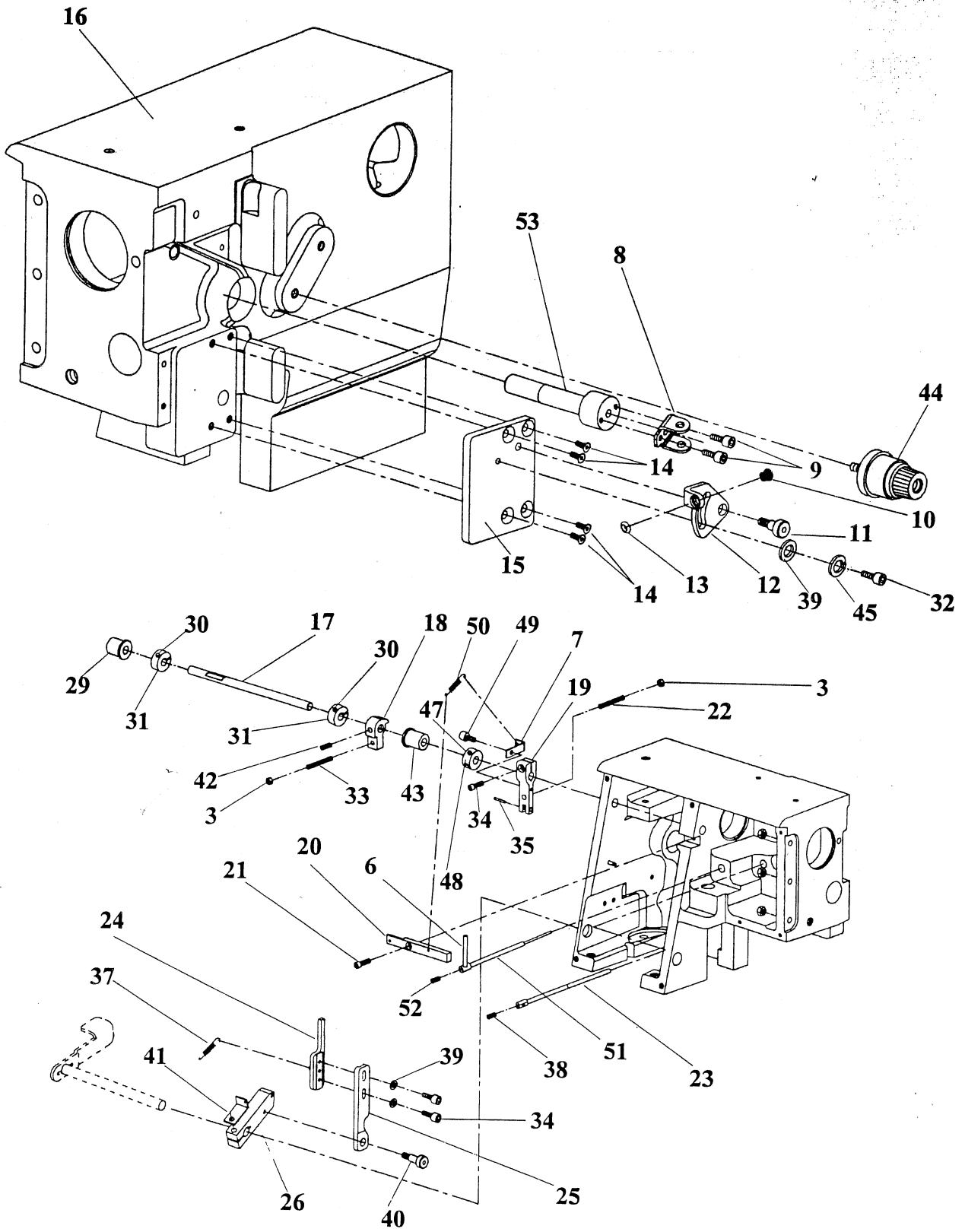

THREAD DRAW-OFF - ISBH MODELS

DET	PART NUMBER	DESCRIPTION
03	08.6700.4.000	M4 Nut
06	22.3053.0.000	Tension Release Pivot
07	22.3052.0.000	Tension Release Mounting Bracket
08	22.3046.0.000	Thread Draw-Off Guide
09	08.6200.3.008	M3 x 8 Screw
10	01.7447.1.000	Guide
11	22.3049.0.000	Shoulder Screw
12	22.3045.0.000	Thread Take-Up
13	01.6551.0.000	Retaining Ring
14	08.6100.4.012	M4 x 12 Fl Screw
15	22.3044.0.000	Thread Take-up Mounting Plate
16	22.6000.1.000	ISBH Head
17	22.3040.0.000	Thread Draw-Off Actuator Shaft
18	22.3037.0.000	Thread Draw-Off Pawl
19	22.3041.0.000	Tension Release Clamp Arm
20	22.3043.0.000	Thread Draw-Off Stop Bracket
21	08.6000.4.012	M4 x 12 Screw
23	22.3042.0.000	Thread Draw-Off Shaft
24	22.3039.0.050	Pawl Actuator Upper Assembly
25	22.3038.0.000	Thread Draw-Off Lower Pawl Actuator
26	22.0406.1.000	Pawl Holder
29	12.2080.1.001	Flange Bushing
30	08.6000.3.010	M3 x 10 Screw
31	22.0183.0.000	Collar Dia.8
32	08.6200.4.008	M4 x 8 BH Screw
33	08.6400.4.020	M4 x 20 Screw
34	08.6000.4.010	M4 x 10 Screw
35	12.1012.0.001	Pin
37	07.6440.0.035	Spring
38	08.6400.3.005	M3 x 5 Set Screw
39	08.6850.4.000	M4 Lockwasher
40	22.0066.0.000	Shoulder Screw
41	22.0055.0.000	Spring Retainer
42	08.6400.5.006	M5 x 6 Set Screw
43	12.2080.1.002	Sleeve Bearing
44	23.2044.0.050	Large Tension Assembly
45	08.6800.4.000	M4 Washer
47	08.6400.5.305	M5 x 0.5-5 Set Screw
48	22.3050.0.000	Eccentric
49	08.6000.4.008	M4 x 8 Screw
50	17.0026.3.173	Spring
51	22.3047.0.000	Tension Release Pin
52	08.6400.4.005	M4 x 5 Set Screw
53	22.3063.0.000	Pin Guide

22 086400 4 012

Revised 4/98

U.S. Phone (800) 237-3323 Fax (800) 432-4303

Outside U.S. Phone (804) 559-5000 Fax (804) 559-5290

CLAMPING - ISBH MODELS

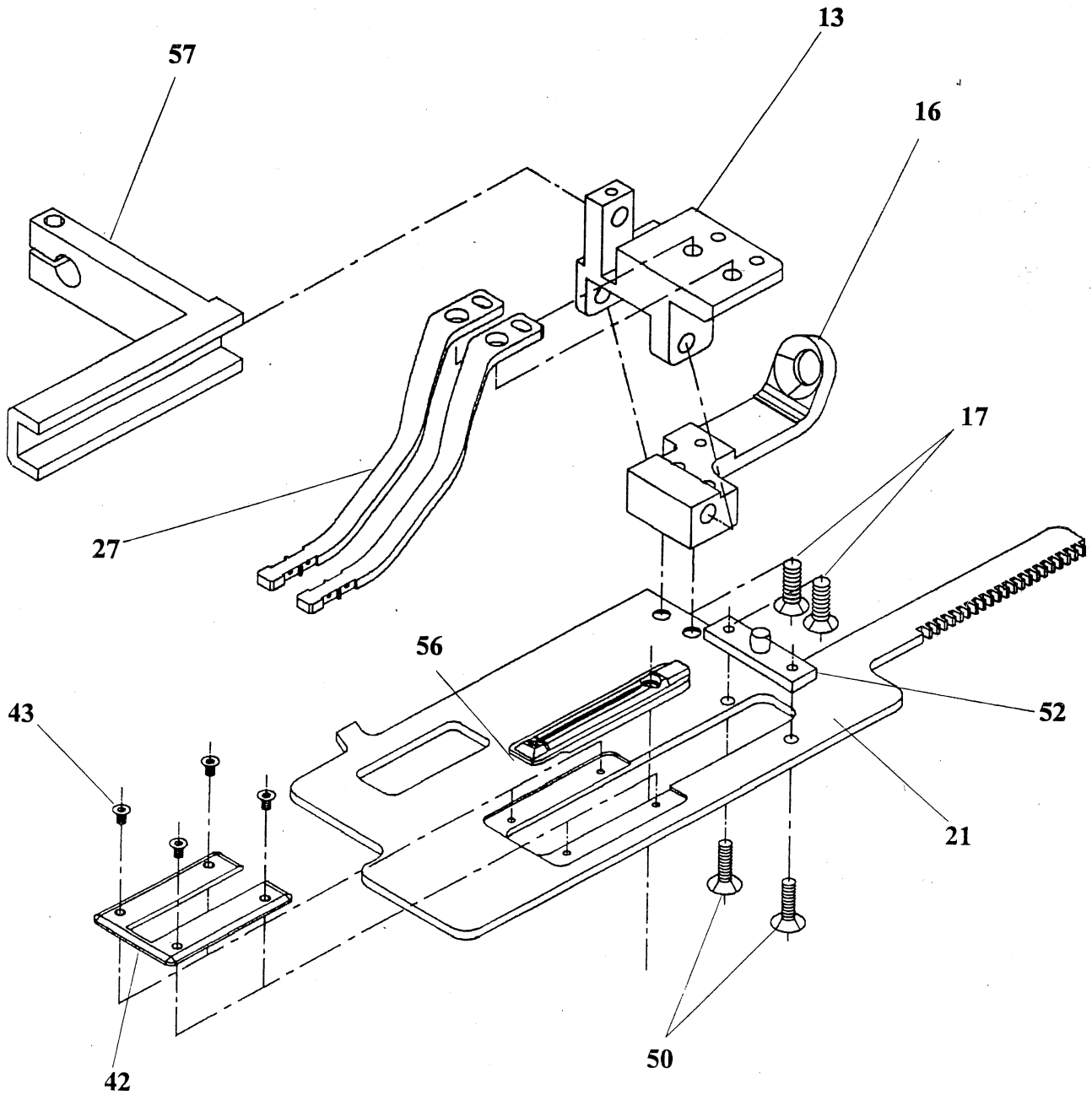

CLAMPING - ISBH MODELS

DET	PART NUMBER	DESCRIPTION
13	22.3026.1.000	Tail Pivot Clamp
16	22.3027.1.000	Tail Bracket Clamp
17	08.6100.5.012	M5 x 12 FH Screw
21	22.3028.1.000	Clamp Plate
27	22.3029.1.000	Clamp Arm (Left and Right)
42	22.0164.0.000	Clamp Mat
43	01.2376.0.000	4-60 Screw
52	22.3036.0.000	Indexer Bracket
56	22.2034.0.000	Throat Plate
57	22.0127.1.000	Clamp Actuation Lever

Revised 4/98

U.S. Phone (800) 237-3323 Fax (800) 432-4303

Outside U.S. Phone (804) 559-5000 Fax (804) 559-5290

PNEUMATICS - ISBH MODELS

**FRONT
 VIEW**

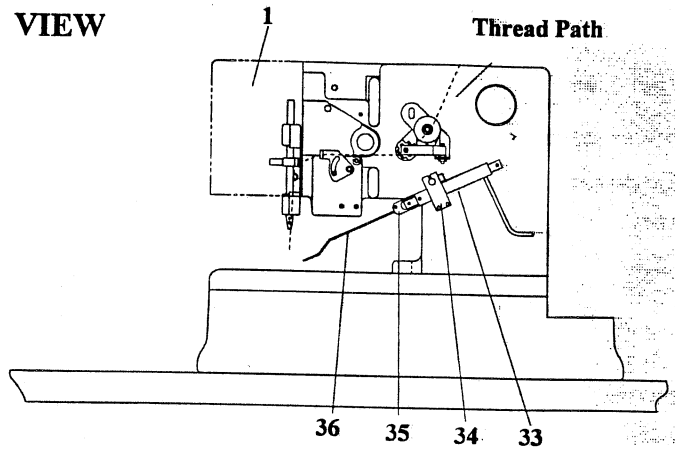

**BACK
 VIEW**

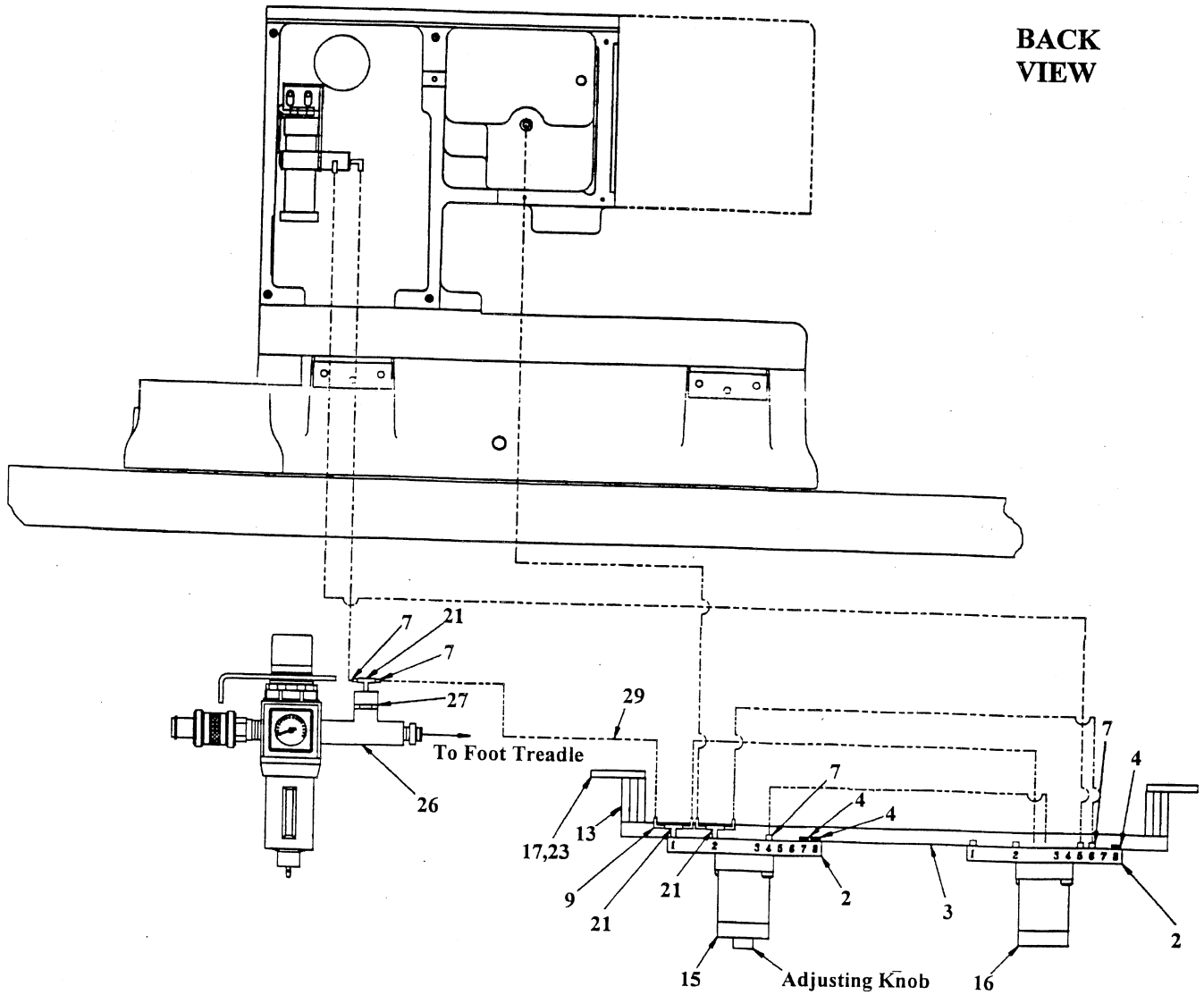

PNEUMATICS - ISBH MODELS

DET	PART NUMBER	DESCRIPTION
01	22.6000.1.000	S2000 ISBH Head
02	07.0120.0.000	Subplate
03	07.0298.0.000	Mounting Strip
04	22521-560	Plug
07	25521-562	#10-32 x 3/32 Connector
09	25521-569	#10-32 x 3/32 Elbow
13	07.0299.0.000	Stand Off Kit
15	07.0296.0.000	Time Delay Valve
16	07.0297.0.000	4-Way Valve
17	01.2713.0.000	#10-32 x 1/2 Screw
20	17.0008.3.071	Valve
21	01.7818.0.000	Tee
23	22.3016.0.000	Air Valve Mounting Plate
26	01.7815.0.000	Street Tee
27	01.7816.0.000	1/4 x #10 Reducing Bushing
29	22998-608	3/32 Tubing
33	12.0008.3.125	Air Cylinder
34	22.3057.0.000	Air Cylinder Bracket
35	17.0064.8.401	Thread Picker Mounting Bracket
36	22.3056.0.000	Thread Picker

Revised 4/98

U.S. Phone (800) 237-3323 Fax (800) 432-4303

Outside U.S. Phone (804) 559-5000 Fax (804) 559-5290

BASE - ISBH MODEL WITH INDEXER

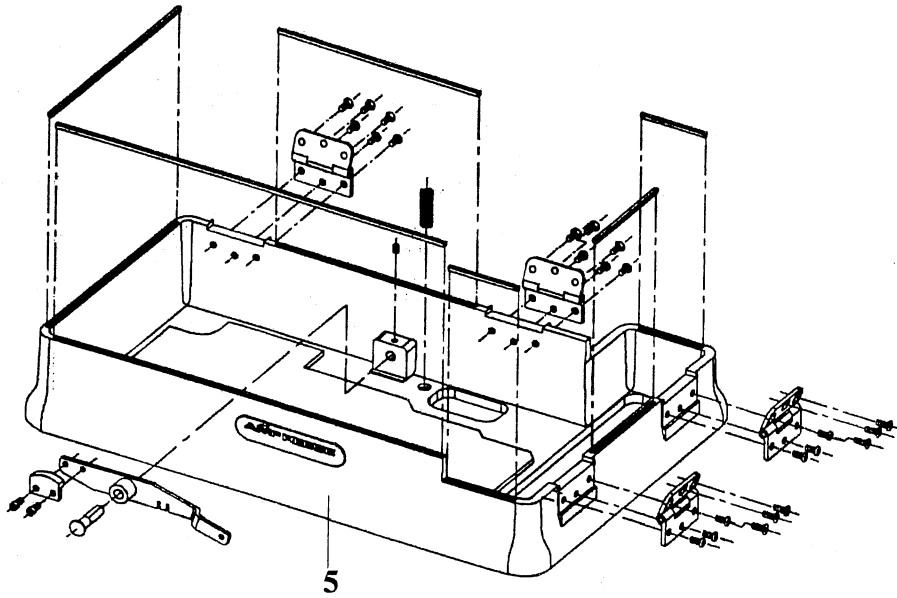

DET	PART NUMBER	DESCRIPTION
05	22.6005.1.000	ISBH with Indexer Base

BEDPLATE - ISBH MODEL WITH INDEXER

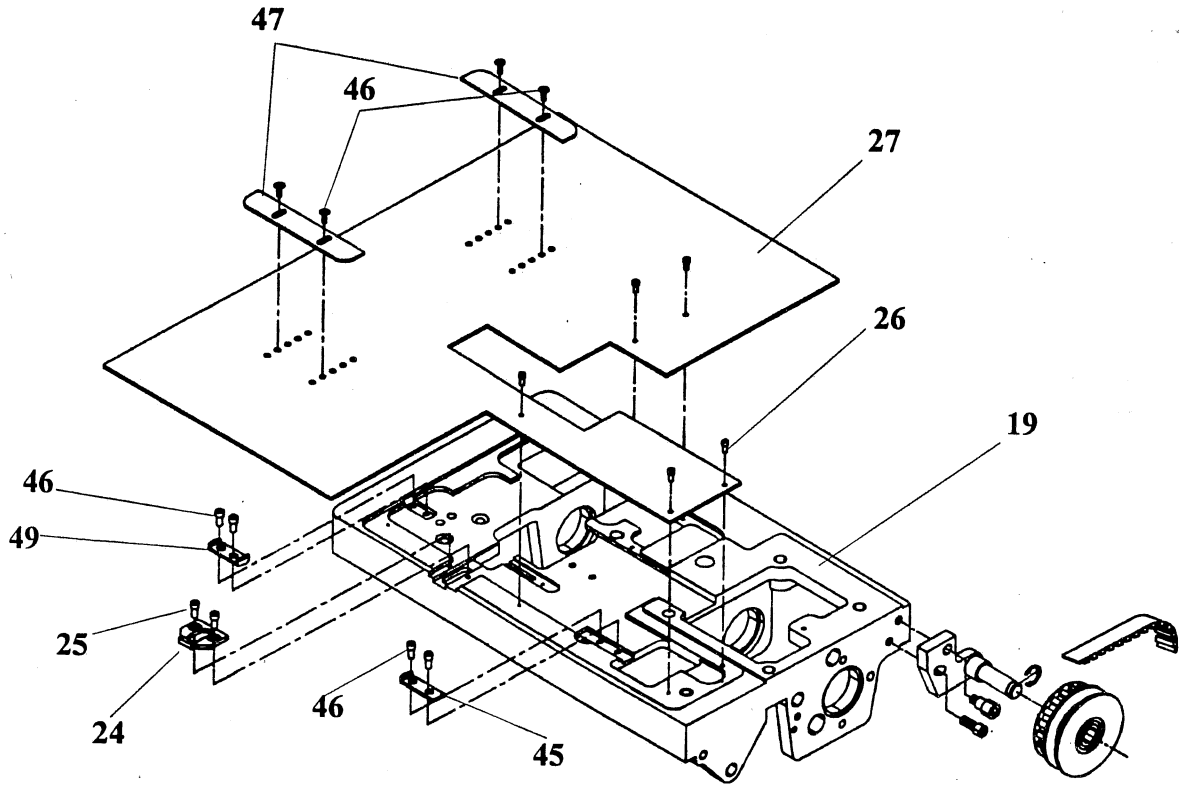

DET	PART NUMBER	DESCRIPTION
19	22.6100.1.000	Bedplate
24	22.0408.1.000	Trimmer Cover Plate
25	08.6100.4.006	M4 x 6 Screw
26	08.6200.3.008	M3 x 8 Screw
27	22.3055.0.000	ISBH with Indexer Cover Plate
45	22.0115.0.000	Stop
46	22.0143.0.000	Screw
47	22.3054.0.000	Material Guide
49	22.3022.0.000	Front Stop

Revised 4/98

U.S. Phone (800) 237-3323 Fax (800) 432-4303

Outside U.S. Phone (804) 559-5000 Fax (804) 559-5290

LUBRICATION

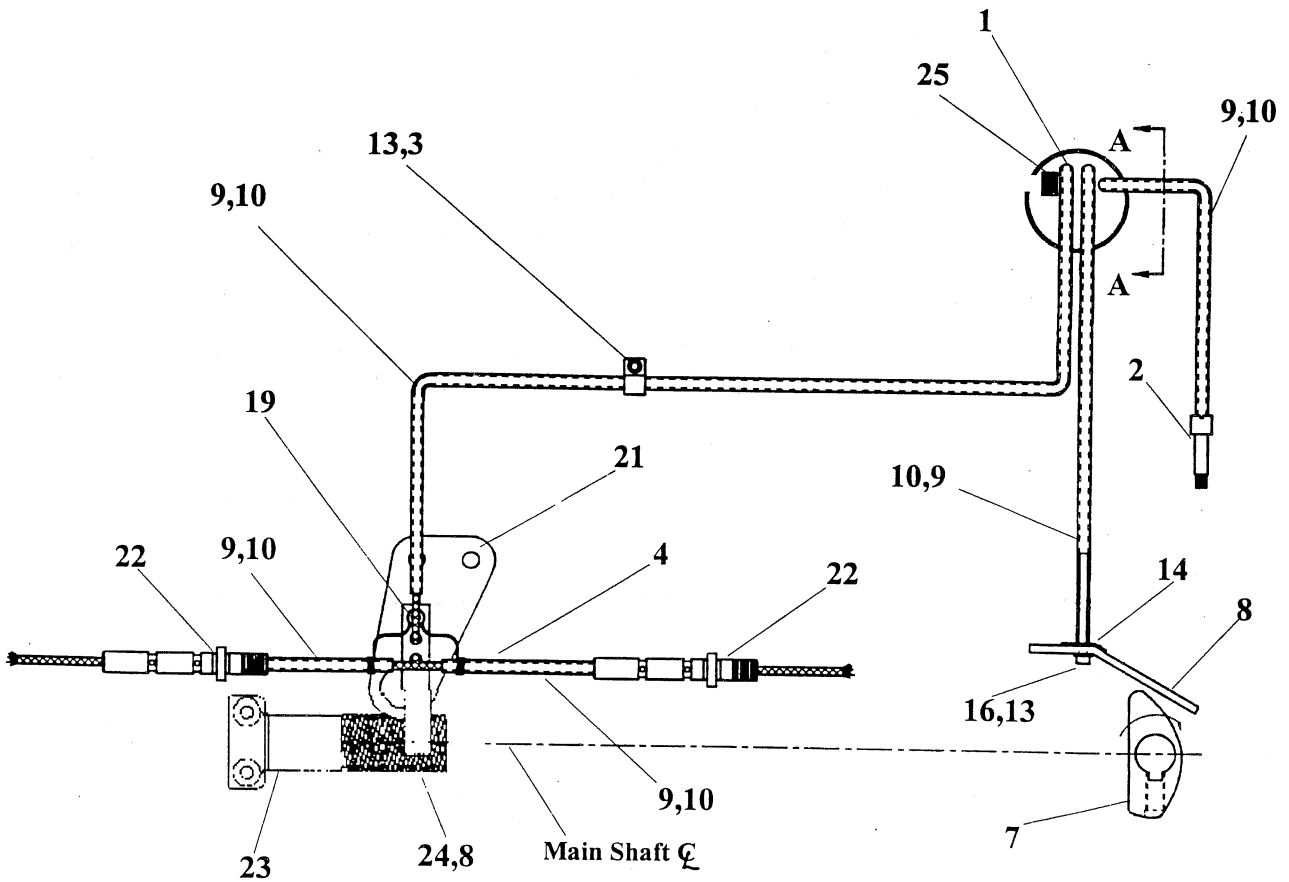
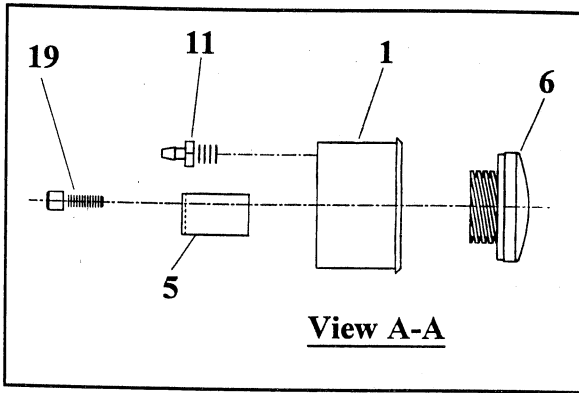

LUBRICATION

DET.	PART NUMBER	DESCRIPTION
01	22.0104.0.000	Oil Gauge Reservoir
02	22.0108.0.000	Wick Holder
03	17.0082.6.000	Clamp
04	17.0027.1.799	Wire
05	22.0120.0.000	Holder
06	17.0095.1.329	Oil Sight Gauge
07	22.6203.0.000	Stop Cam
08	17.0094.5.310	Felt
09	22.0141.0.000	Tubing
10	22.0139.0.000	Lubricating Wick
11	25521-536	Straight Fitting
13	08.6000.3.006	M3 x 6 Screw
14	22.0270.0.000	Bracket
16	08.6850.3.000	M3 Washer
19	08.6000.4.006	M4 x 6 Screw
21	22.0097.0.000	Main Cam Brace
22	22.0022.0.000	Looper Pivot Shaft/Feed Pivot Shaft
23	22.8400.0.000	Shaft Worm Gear
24	22.0107.0.000	Worm Gear Felt Retainer
25	01.2140.0.000	10-32 Plug

Revised 4/98

U.S. Phone (800) 237-3323 Fax (800) 432-4303

Outside U.S. Phone (804) 559-5000 Fax (804) 559-5290

NEEDLES

PART NO.	SIZE	TYPE	APPLICATIONS
02.0750.1.400 02.0750.0.000 02.0750.0.000	Extremely Fine Extra Fine Very Fine	Round Point Long Shank	Applicable to the majority of woven fabrics, knits and materials of similar consistency. These needles have a long shank that gives added stiffness to the blade permitting the use of one size smaller needle than would be normally required. Cannot be used on heavy materials that would be penetrated by the tapered portion of the needle's shank.
02.0750.2.110 02.0750.0.111 02.0750.3.112	Fine Medium Heavy	Round Point	Applicable to the majority of woven fabrics, knits and materials similar consistency.
02.0751.1.400 02.0751.1.000 02.0751.1.000	Extremely Fine Extra Fine Very Fine	Ball Point Long Shank	Applicable to tightly woven or knitted fabrics, particularly silks and synthetics when the fibers of the materials are subject to damage or fracture by conventional Round Point needles. The Long Shank of this needle gives it the advantages stated for Round Point Shank needles.
02.0751.0.110 02.0751.3.111	Fine Medium	Ball Point	Same application as the Long Shank Ball Point needle above.
02.0752.0.110 02.0752.3.111 02.0752.3.112	Fine Medium Heavy	Spear Point	Applicable to fabrics containing a high percentage of starch or similar substances that tend to cause needle heating or resistance to proper pulling up of the stitches.
02.0752.0.211 02.0752.0.212	Medium Heavy	Spear Point Double Groove	The Double Groove needle should be used only when the conditions justify it because it casts a smaller loop than standard needles and may introduce skipping. For this reason, looper points should be set close to the needle blade. This needle is used on materials that have a tendency to trap the thread in its descent into the work which affects the thread take-up, or causes the thread to break at the needle's eye.
02.0753.1.100	Very Fine Long Shank	Cross Point	Applicable to fine leather and similar materials as well as some types of plastics where conventional needles tend to leave excessive punctures. This needle permits a higher stitch density than Round Point needle. There may be a tendency in some cases for the materials to cling to this needle; therefore, it should be used only after comparative test with other needles. The Long Shank of this needle gives it the advantages stated for Round Point Long Shank needles.
02.0753.3.110 02.0753.0.112	Fine Heavy	Cross Point	The same applications as the Cross Point Long Shank needle above.
02.0754.0.110 02.0754.0.111	Fine Medium	Rocked Point	Applicable to leather and similar materials where conventional sharp pointed needles tend to leave excessive punctures. The slit made by the Rocked Point needle will tend to close up after penetration. This needle permits a higher stitch density than is possible in leather with a round point needle.

Needles for the AMF Reece Series S2000 machines are packaged and sold in boxes of 100, in the sizes and types listed. They are of superior struck groove construction, chrome plated and are spotted at the eye except in sizes 00 and finer. When ordering, specify quantity (100, 200, etc.) and give the needle part number.

NOTES

This page intentionally left blank.

Released 2/98

U.S. Phone (800) 237-3323 Fax (800) 432-4303

Outside U.S. Phone (804) 559-5000 Fax (804) 559-5290

3-55

LUBRICATION

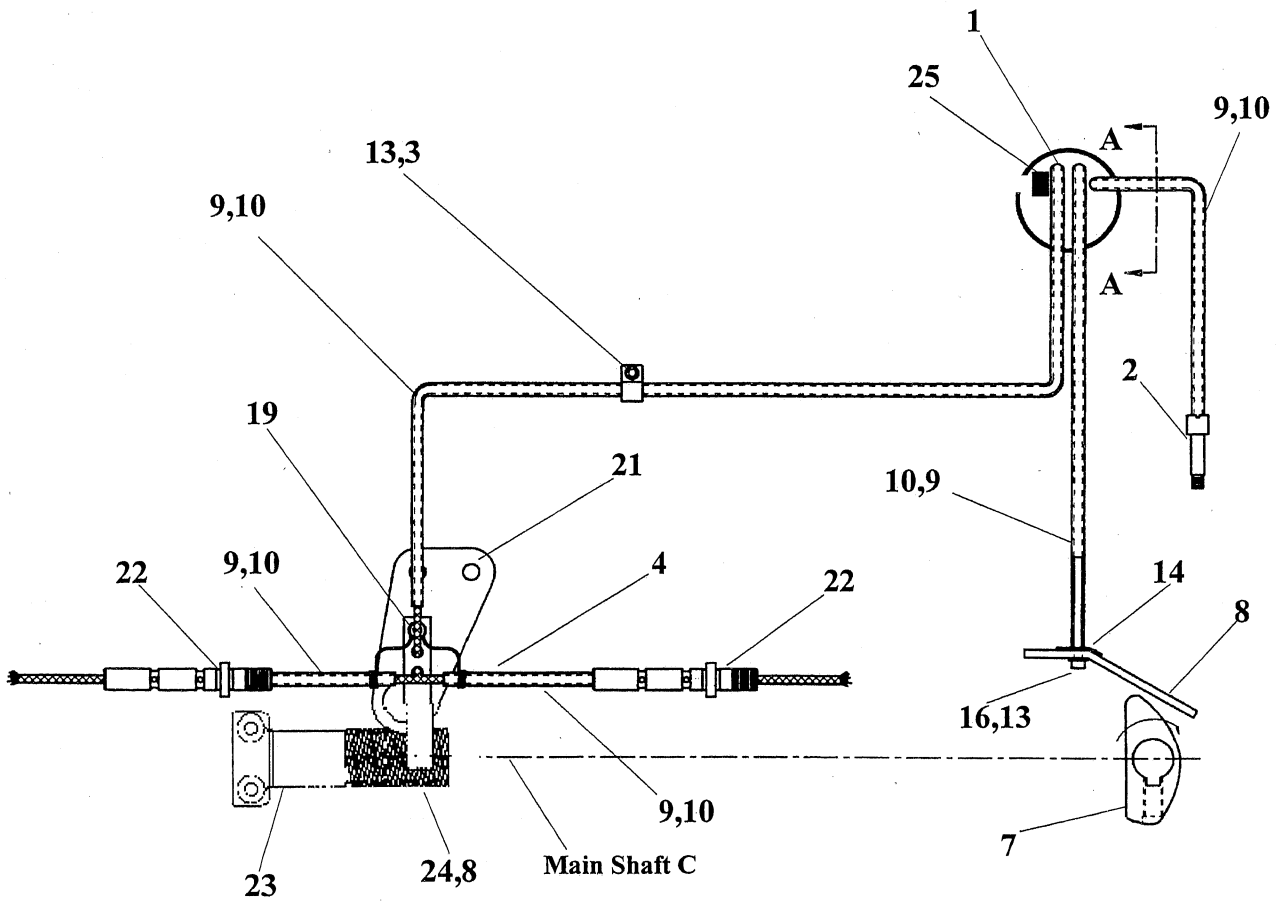
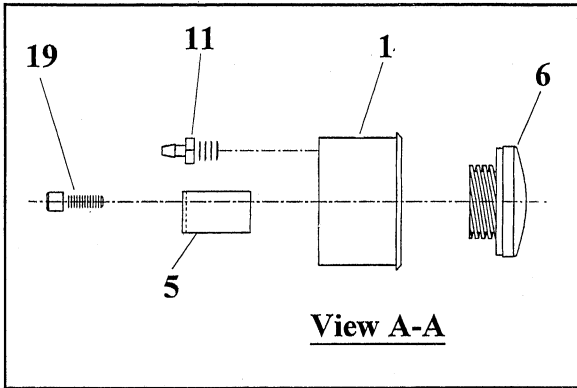

LUBRICATION

DET.	PART NUMBER	DESCRIPTION
01	22.0104.0.000	Oil Gauge Reservoir
02	22.0108.0.000	Wick Holder
03	17.0082.6.000	Clamp
04	17.0027.1.799	Wire
05	22.0120.0.000	Holder
06	17.0095.1.329	Oil Sight Gauge
07	22.6203.0.000	Stop Cam
08	17.0094.5.310	Felt
09	22.0141.0.000	Tubing
10	22.0139.0.000	Lubricating Wick
11	25521-536	Straight Fitting
13	08.6000.3.006	M3 x 6 Screw
14	22.0270.0.000	Bracket
16	08.6850.3.000	M3 Washer
19	08.6000.4.006	M4 x 6 Screw
21	22.0097.0.000	Main Cam Brace
22	22.0022.0.000	Looper Pivot Shaft/Feed Pivot Shaft
23	22.8400.0.000	Shaft Worm Gear
24	22.0107.0.000	Worm Gear Felt Retainer
25	01.2140.0.000	10-32 Plug

Released 2/98

U.S. Phone (800) 237-3323 Fax (800) 432-4303

Outside U.S. Phone (804) 559-5000 Fax (804) 559-5290

NEEDLES

PART NO.	SIZE	TYPE	APPLICATIONS
02.0750.1.400	Extremely Fine	Round Point	Applicable to the majority of woven fabrics, knits and materials of similar consistency. These needles have a long shank that gives added stiffness to the blade permitting the use of one size smaller needle than would be normally required. Cannot be used on heavy materials that would be penetrated by the tapered portion of the needle's shank.
02.0750.0.000	Extra Fine	Long Shank	
02.0750.0.000	Very Fine		
02.0750.2.110	Fine	Round Point	Applicable to the majority of woven fabrics, knits and materials similar consistency.
02.0750.0.111	Medium		
02.0750.3.112	Heavy		
02.0751.1.400	Extremely Fine	Ball Point	Applicable to tightly woven or knitted fabrics, particularly silks and synthetics when the fibers of the materials are subject to damage or fracture by conventional Round Point needles. The Long Shank of this needle gives it the advantages stated for Round Point Shank needles.
02.0751.1.000	Extra Fine	Long Shank	
02.0751.1.000	Very Fine		
02.0751.0.110	Fine	Ball Point	Same application as the Long Shank Ball Point needle above.
02.0751.3.111	Medium		
02.0752.0.110	Fine	Spear Point	Applicable to fabrics containing a high percentage of starch or similar substances that tend to cause needle heating or resistance to proper pulling up of the stitches.
02.0752.3.111	Medium		
02.0752.3.112	Heavy		
02.0752.0.211	Medium	Spear Point	The Double Groove needle should be used only when the conditions justify it because it casts a smaller loop than standard needles and may introduce skipping. For this reason, looper points should be set close to the needle blade. This needle is used on materials that have a tendency to trap the thread in its descent into the work which affects the thread take-up, or causes the thread to break at the needle's eye.
02.0752.0.212	Heavy	Double Groove	
02.0753.1.100	Very Fine Long Shank	Cross Point	Applicable to fine leather and similar materials as well as some types of plastics where conventional needles tend to leave excessive punctures. This needle permits a higher stitch density than Round Point needle. There may be a tendency in some cases for the materials to cling to this needle; therefore, it should be used only after comparative test with other needles. The Long Shank of this needle gives it the advantages stated for Round Point Long Shank needles.
02.0753.3.110	Fine	Cross Point	The same applications as the Cross Point Long Shank needle above.
02.0753.0.112	Heavy		
02.0754.0.110	Fine	Rocked Point	Applicable to leather and similar materials where conventional sharp pointed needles tend to leave excessive punctures. The slit made by the Rocked Point needle will tend to close up after penetration. This needle permits a higher stitch density than is possible in leather with a round point needle.
02.0754.0.111	Medium		

Needles for the AMF Reece Series S2000 machines are packaged and sold in boxes of 100, in the sizes and types listed. They are of superior struck groove construction, chrome plated and are spotted at the eye except in sizes 00 and finer. When ordering, specify quantity (100, 200, etc.) and give the needle part number.

Released 2/97

INDEX

PART NUMBER	DET	PAGE
22521560		
22521560	4	3-49
22998608	29	3-49
25521536	11	3-53
25521562	7	3-49
25521569	9	3-49
01.1382.0.000		
01.1382.0.000	04	3-15
01.1397.0.000	08	3-15
01.2084.0.000	29	3-29
01.2140.0.000	25	3-53
01.2193.0.000	02	3-3
01.2376.0.000	43	3-5
01.2376.0.000	43	3-47
01.2386.0.000	11	3-7
01.2713.0.000	17	3-49
01.4980.0.000	35	3-13
01.4980.0.000	23	3-15
01.4980.0.000	26	3-19
01.5033.0.000	05	3-7
01.5162.0.000	08	3-7
01.6551.0.000	30	3-23
01.6551.0.000	07	3-3
01.6551.0.000	13	3-45
01.7147.0.000	14	3-27
01.7149.0.000	18	3-27
01.7447.1.000	34	3-23
01.7447.1.000	04	3-3
01.7447.1.000	10	3-45
01.7622.0.000	03	3-29
01.7804.0.000	18	3-3
01.7805.0.000	07	3-29
01.7805.0.000	23	3-3
01.7806.0.000	21	3-27
01.7809.0.000	17	3-3
01.7815.0.000	26	3-49
01.7816.0.000	27	3-49
01.7818.0.000	21	3-49
02.0750.2.110	07	3-40
03.0018.0.000		
03.0018.0.000	01	3-40
03.0197.0.000	06	3-40
03.0198.0.000	06	3-40
03.0199.0.000	06	3-40
03.0200.0.000	06	3-40
03.6400.5.010	22	3-29

PART NUMBER	DET	PAGE
04.1956.0.000		
04.1956.0.000	20	3-33
04.9000.0.802	13	3-35
04.9000.0.802	13	3-39
05.1322.0.000	03	3-40
05.1391.0.000	12	3-17
05.4113.0.000	3	3-27
07.0120.0.000	02	3-49
07.0296.0.000	15	3-49
07.0297.0.000	16	3-49
07.0298.0.000	03	3-49
07.0299.0.000	13	3-49
07.6045.0.002		
07.6045.0.002	16	3-11
07.6045.0.009	32	3-13
07.6045.0.009	14	3-7
07.6045.0.034	30	3-13
07.6045.0.034	32	3-29
07.6045.0.037	53	3-13
07.6045.0.037	9	3-27
07.6045.0.037	21	3-29
07.6045.0.037	53	3-47
07.6045.0.037	53	3-52
07.6045.0.043	35	3-11
07.6045.0.046	47	3-5
07.6045.0.047	08	3-5
07.6045.0.049	13	3-7
07.6045.0.050	5	3-25
07.6045.0.053	23	3-27
07.6045.0.054	20	3-29
07.6242.0.000	36	3-29
07.6243.0.000	17	3-21
07.6321.0.001	30	3-25
07.6321.0.001	27	3-43
07.6321.0.003	06	3-21
07.6321.0.006	07	3-21
07.6321.0.025	18	3-13
07.6321.0.025	18	3-15
07.6321.0.025	11	3-19
07.6321.0.029	20	3-19
07.6440.0.018		
07.6440.0.018	23	3-13
07.6440.0.020	21	3-11
07.6440.0.021	38	3-11
07.6440.0.025	02	3-11
07.6440.0.027	10	3-11
07.6440.0.028	40	3-13
07.6440.0.028	18	3-19

PART NUMBER	DET	PAGE
07.6440.0.029		
07.6440.0.029	14	3-5
07.6440.0.030	18	3-5
07.6440.0.031	22	3-5
07.6440.0.032	04	3-21
07.6440.0.033	33	3-13
07.6440.0.034	25	3-23
07.6440.0.035	03	3-23
07.6440.0.035	37	3-45
07.6440.0.036	27	3-15
07.6440.0.037	24	3-25
07.6440.0.037	23	3-43
07.6440.0.039	02	3-17
07.6440.0.040	14	3-9
07.6440.0.041	44	3-13
07.6440.0.043	23	3-21
07.6440.0.044	48	3-5
07.6440.0.045	29	3-25
07.6440.0.045	28	3-43
07.6440.0.046	28	3-25
07.6440.0.051	6	3-27
07.6440.0.051	54	3-47
07.6850.6.000	07	3-37
07.7816.0.000	27	3-51
08.6000.3.006		
08.6000.3.006	25	3-3
08.6000.3.006	13	3-53
08.6000.3.010	50	3-13
08.6000.3.010	31	3-15
08.6000.3.010	27	3-19
08.6000.3.010	30	3-45
08.6000.3.012	11	3-35
08.6000.3.012	11	3-37
08.6000.3.016	03	3-31
08.6000.4.005	04	3-9
08.6000.4.006	07	3-31
08.6000.4.006	19	3-53
08.6000.4.008	08	3-17
08.6000.4.008	19	3-27
08.6000.4.008	39	3-5
08.6000.4.008	49	3-45
08.6000.4.010	22	3-11
08.6000.4.010	15	3-40
08.6000.4.010	34	3-45
08.6000.4.010	15	3-9
08.6000.4.012	43	3-23
08.6000.4.012	21	3-45
08.6000.4.012	01	3-9

INDEX

PART NUMBER	DET	PAGE
08.6000.4.014		
08.6000.4.014	12	3-13
08.6000.4.014	11	3-15
08.6000.4.014	05	3-19
08.6000.4.016	10	3-23
08.6000.4.020	23	3-23
08.6000.4.020	49	3-5
08.6000.4.025	06	3-35
08.6000.4.025	06	3-39
08.6000.5.008		
08.6000.5.008	28	3-23
08.6000.5.010	11	3-40
08.6000.5.012	29	3-11
08.6000.5.012	19	3-7
08.6000.5.016	30	3-27
08.6000.5.020	31	3-13
08.6000.5.020	34	3-5
08.6000.5.025	05	3-21
08.6000.5.025	01	3-7
08.6000.6.008	14	3-11
08.6000.6.008	26	3-5
08.6000.6.012	16	3-21
08.6000.6.018	24	3-23
08.6000.6.020	35	3-29
08.6000.6.020	07	3-33
08.6000.6.020	25	3-33
08.6000.6.020	12	3-37
08.6000.6.020	36	3-37
08.6000.6.025	02	3-19
08.6000.6.030	15	3-3
08.6000.8.025	25	3-27
08.6000.8.040	15	3-27
08.6000.8.055	19	3-40
08.6000.8.055	34	3-33
08.6000.8.055	03	3-37
08.6100.3.008	23	3-19
08.6100.3.030	36	3-13
08.6100.4.006	06	3-9
08.6100.4.006	25	3-29
08.6100.4.006	13	3-33
08.6100.4.006	13	3-37
08.6100.4.006	25	3-51
08.6100.4.010	30	3-5
08.6100.4.012	23	3-25
08.6100.4.012	22	3-43
08.6100.4.012	14	3-45
08.6100.5.010	10	3-25
08.6100.5.010	09	3-43

PART NUMBER	DET	PAGE
08.6100.5.012		
08.6100.5.012	11	3-17
08.6100.5.012	10	3-31
08.6100.5.012	17	3-47
08.6100.5.012	17	3-5
08.6100.5.020	02	3-15
08.6100.5.020	12	3-27
08.6100.6.012	19	3-21
08.6200.3.008		
08.6200.3.008	26	3-29
08.6200.3.008	09	3-45
08.6200.3.008	26	3-51
08.6200.4.006	15	3-23
08.6200.4.008	06	3-31
08.6200.4.008	32	3-45
08.6200.4.010	14	3-21
08.6200.4.010	35	3-23
08.6200.4.016	33	3-23
08.6200.5.008	22	3-27
08.6200.5.012	04	3-17
08.6200.5.060	28	3-37
08.6200.6.025	31	3-3
08.6302.6.025	31	3-37
08.6400.3.005	12	3-3
08.6400.3.005	38	3-45
08.6400.4.004	25	3-15
08.6400.4.004	37	3-23
08.6400.4.004	41	3-29
08.6400.4.004	21	3-3
08.6400.4.004	12	3-5
08.6400.4.005	08	3-13
08.6400.4.005	22	3-23
08.6400.4.005	52	3-45
08.6400.4.006	08	3-11
08.6400.4.006	44	3-29
08.6400.4.012	44	3-5
08.6400.4.020	23	3-11
08.6400.4.020	40	3-29
08.6400.4.020	33	3-45
08.6400.4.025	07	3-13
08.6400.5.005	28	3-13
08.6400.5.005	05	3-3
08.6400.5.006	42	3-45
08.6400.5.008	10	3-17
08.6400.5.008	20	3-21
08.6400.5.008	38	3-29
08.6400.5.010	24	3-27
08.6400.5.010	19	3-5

PART NUMBER	DET	PAGE
08.6400.5.012		
08.6400.5.012	17	3-52
08.6400.5.305	10	3-29
08.6400.5.305	49	3-45
08.6400.6.010	02	3-21
08.6400.8.008	06	3-29
08.6700.0.000	04	3-11
08.6700.3.000	07	3-35
08.6700.3.000	07	3-33
08.6700.4.000	44	3-23
08.6700.4.000	39	3-29
08.6700.4.000	03	3-45
08.6700.4.000	29	3-5
08.6700.5.000	07	3-19
08.6700.5.000	15	3-21
08.6700.5.000	21	3-21
08.6700.5.000	40	3-23
08.6700.5.000	21	3-25
08.6700.5.000	13	3-27
08.6700.5.000	20	3-43
08.6700.5.000	03	3-5
08.6700.5.000	46	3-5
08.6700.6.000	18	3-33
08.6700.8.000	51	3-13
08.6700.8.000	16	3-15
08.6702.5.000	19	3-37
08.6710.4.000	17	3-11
08.6710.5.000	16	3-13
08.6710.5.000	22	3-15
08.6710.6.000	22	3-21
08.6710.8.000	37	3-11
08.6710.8.400	34	3-11
08.6733.3.000	39	3-13
08.6800.4.000		
08.6800.4.000	52	3-13
08.6800.4.000	12	3-15
08.6800.4.000	32	3-23
08.6800.4.000	05	3-39
08.6800.4.000	45	3-45
08.6800.5.000	40	3-11
08.6800.6.000	13	3-11
08.6800.6.000	06	3-33
08.6800.6.000	09	3-37
08.6802.3.000	08	3-39
08.6802.5.000	21	3-37
08.6850.3.000	16	3-53
08.6850.4.000	31	3-23
08.6850.4.000	39	3-45

INDEX

PART NUMBER	DET	PAGE
08.6850.5.000		
08.6850.5.000	20	3-25
08.6850.5.000	29	3-27
08.6852.5.000	19	3-43
08.6850.6.000	05	3-33
08.6850.6.000	07	3-37
08.6852.5.000	22	3-37
08.6870.0.001	33	3-33
08.6870.0.001	04	3-37
08.6870.8.001	18	3-40
08.6900.3.020	36	3-11
12.0008.3.013		
12.0008.3.013	37	3-37
12.0008.3.075	11	3-33
12.0008.3.075	10	3-37
12.0008.3.083	40	3-33
12.0008.3.083	50	3-37
12.0008.3.084	10	3-35
12.0008.3.084	10	3-39
12.0008.3.085	15	3-33
12.0008.3.085	48	3-37
12.0008.3.086	24	3-33
12.0008.3.086	38	3-37
12.0008.3.087	29	3-33
12.0008.3.087	40	3-37
12.0008.3.089	23	3-33
12.0008.3.089	25	3-37
12.0008.3.091	39	3-33
12.0008.3.092	36	3-33
12.0008.3.092	45	3-37
12.0008.3.093	35	3-33
12.0008.3.094	26	3-37
12.0008.3.097	51	3-37
12.0008.3.125	33	3-49
12.0008.4.500	01	3-35
12.0008.4.500	01	3-37
12.0008.6.001	04	3-40
12.0008.6.500	41	3-33
12.0008.6.500	52	3-37
12.0008.6.501	01	3-35
12.0008.6.501	01	3-39
12.0008.6.502	02	3-35
12.0008.6.502	02	3-39
12.0008.6.503	03	3-35
12.0008.6.503	03	3-39
12.0008.6.900	02	3-33
12.0008.6.900	43	3-37
12.0008.6.901	30	3-33
12.0008.6.901	55	3-37

PART NUMBER	DET	PAGE
12.0008.6.902		
12.0008.6.902	10	3-33
12.0008.6.902	08	3-37
12.1011.0.001	28	3-27
12.1012.0.001	35	3-45
12.1015.0.001	26	3-27
12.1045.2.001	17	3-29
12.2080.1.001	29	3-45
12.2080.1.002	43	3-45
12.5050.1.000	49	3-37
12.5050.1.001	38	3-33
12.5050.1.001	49	3-37
12.5050.1.002	38	3-33
17.0007.8.171		
17.0007.8.171	19	3-33
17.0007.8.171	32	3-37
17.0007.8.172	19	3-33
17.0007.8.172	32	3-37
17.0007.8.173	19	3-33
17.0007.8.173	32	3-37
17.0008.3.071	20	3-49
17.0019.0.517	54	3-13
17.0019.2.057	41	3-13
17.0026.3.173	50	3-45
17.0027.1.799	04	3-53
17.0064.8.401	35	3-49
17.0082.6.000	03	3-53
17.0094.5.310	08	3-53
17.0095.1.272	44	3-33
17.0095.1.272	56	3-37
17.0095.1.272	17	3-40
17.0095.1.273	32	3-33
17.0095.1.273	05	3-37
17.0095.1.273	16	3-40
17.0095.1.329	06	3-53
20.0092.0.004	10	3-7
20.0093.2.004	09	3-40
20.0093.2.004	09	3-7
20.0094.0.000	05	3-15
20.0094.0.000	08	3-40
20.0094.1.000	08	3-40
20.0111.0.000	06	3-15
20.0112.0.000	09	3-15
20.0164.0.000	42	3-5
20.0196.1.330	40	3-5
20.0196.1.331	41	3-5
20.0196.1.336	40	3-5
20.0196.1.337	41	3-5
20.0587.0.000	08	3-3

PART NUMBER	DET	PAGE
22.0588.0.000		
20.0588.0.000	09	3-3
20.0641.2.000	04	3-7
22.0000.0.078		
22.0000.0.078	09	3-33
22.0000.0.078	06	3-37
22.0005.0.000	25	3-19
22.0006.0.000	11	3-29
22.0008.0.000	01	3-19
22.0008.0.000	42	3-37
22.0009.0.000	21	3-19
22.0010.0.000	12	3-40
22.0011.0.000	10	3-40
22.0012.0.000	14	3-40
22.0014.0.000	16	3-7
22.0016.0.000	31	3-5
22.0020.0.000	17	3-19
22.0021.0.000	13	3-13
22.0021.0.000	13	3-15
22.0022.0.000	14	3-13
22.0022.0.000	15	3-15
22.0022.0.000	22	3-53
22.0023.0.000	14	3-15
22.0024.0.000	24	3-15
22.0025.0.000	19	3-13
22.0026.0.000	21	3-13
22.0027.0.000	13	3-19
22.0028.0.000	12	3-19
22.0029.0.000	09	3-19
22.0030.0.000		
22.0030.0.000	10	3-19
22.0031.0.000	49	3-13
22.0031.0.000	19	3-15
22.0032.0.000	20	3-13
22.0032.0.000	17	3-15
22.0033.0.000	08	3-19
22.0034.0.000	18	3-23
22.0035.0.000	17	3-23
22.0037.0.000	02	3-31
22.0038.0.000	01	3-17
22.0040.0.000	21	3-23
22.0041.0.000	20	3-23
22.0042.0.000	01	3-23
22.0043.0.000	28	3-5
22.0044.0.000	13	3-40
22.0045.0.000	12	3-11
22.0046.0.000	29	3-23
22.0049.0.000	46	3-13

INDEX

PART NUMBER	DET	PAGE
22.0050.0.000		
22.0050.0.000	45	3-5
22.0051.0.000	06	3-17
22.0052.0.000	17	3-27
22.0053.0.000	16	3-27
22.0054.0.000	01	3-27
22.0055.0.000	20	3-27
22.0056.0.000	23	3-5
22.0057.0.000	08	3-31
22.0058.0.000	04	3-27
22.0060.0.000	10	3-21
22.0061.0.000	01	3-13
22.0062.0.000	07	3-27
22.0063.0.000	24	3-19
22.0064.0.000	19	3-19
22.0065.0.000	31	3-29
22.0066.0.000	19	3-23
22.0066.0.000	40	3-45
22.0068.0.000	02	3-5
22.0069.0.000	16	3-19
22.0070.0.000		
22.0070.0.000	31	3-33
22.0071.0.000	35	3-5
22.0072.0.000	38	3-5
22.0073.0.000	07	3-11
22.0074.0.000	17	3-7
22.0075.0.000	26	3-11
22.0076.0.000	11	3-11
22.0077.0.000	29	3-3
22.0078.0.050	33	3-29
22.0080.0.000	06	3-7
22.0082.0.000	02	3-7
22.0084.0.000	28	3-11
22.0088.0.000	09	3-17
22.0089.0.000	30	3-11
22.0090.0.050	04	3-33
22.0090.0.050	34	3-37
22.0091.0.000	38	3-23
22.0092.0.000	27	3-5
22.0093.0.000	20	3-5
22.0094.0.000	36	3-23
22.0095.0.000	27	3-11
22.0096.0.000	43	3-29
22.0097.0.000	2	3-25
22.0097.0.000	02	3-43
22.0097.0.000	21	3-53
22.0098.0.000	46	3-37

PART NUMBER	DET	PAGE
22.0100.0.000		
22.0100.0.000	09	3-11
22.0100.0.000	17	3-13
22.0100.0.000	21	3-15
22.0100.0.000	03	3-19
22.0104.0.000	01	3-53
22.0105.0.000	20	3-15
22.0106.0.000	3	3-25
22.0106.0.000	03	3-43
22.0107.0.000	24	3-53
22.0108.0.000	02	3-53
22.0110.0.000	15	3-13
22.0110.0.000	04	3-19
22.0111.0.000	13	3-17
22.0112.0.000	11	3-31
22.0114.0.000	42	3-13
22.0115.0.000	45	3-29
22.0115.0.000	45	3-51
22.0117.0.000	34	3-13
22.0119.0.000	05	3-31
22.0120.0.000	05	3-53
22.0121.0.000	06	3-13
22.0124.0.000	5	3-27
22.0125.0.000	21	3-5
22.0127.0.000	32	3-5
22.0127.1.000	57	3-47
22.0128.0.000	43	3-33
22.0137.0.000	9	3-25
22.0137.0.000	08	3-43
22.0139.0.000	10	3-53
22.0140.0.000	06	3-5
22.0141.0.000	09	3-53
22.0143.0.000	46	3-29
22.0143.0.000	46	3-51
22.0145.0.000	42	3-23
22.0148.0.000	27	3-37
22.0148.0.000	30	3-37
22.0153.0.000		
22.0153.0.000	37	3-29
22.0154.0.000	23	3-29
22.0157.0.000	13	3-5
22.0158.0.000	16	3-5
22.0159.0.000	24	3-5
22.0161.0.000	39	3-23
22.0163.0.000	24	3-21
22.0164.0.000	42	3-47
22.0166.0.000	07	3-7
22.0168.0.000	25	3-11

PART NUMBER	DET	PAGE
22.0170.0.000		
22.0170.0.000	07	3-5
22.0171.0.000	15	3-5
22.0173.0.000	11	3-5
22.0174.0.000	04	3-5
22.0175.0.000	27	3-3
22.0176.0.000	36	3-3
22.0177.0.000	35	3-3
22.0178.0.000	34	3-3
22.0179.0.000	33	3-3
22.0180.0.000	25	3-5
22.0181.0.000	18	3-7
22.0182.0.000	24	3-11
22.0182.0.000	1	3-25
22.0182.0.000	01	3-43
22.0183.0.000	22	3-13
22.0183.0.000	26	3-15
22.0183.0.000	06	3-19
22.0183.0.000	31	3-45
22.0184.0.000	24	3-13
22.0186.0.000	45	3-13
22.0188.0.000	16	3-23
22.0189.0.000	16	3-29
22.0190.0.000	30	3-29
22.0191.0.000	05	3-29
22.0194.0.000	54	3-37
22.0195.0.000	01	3-3
22.0197.0.000	42	3-33
22.0197.0.000	53	3-37
22.0198.0.000	27	3-33
22.0200.0.050		
22.0200.0.050	11	3-21
22.0203.0.000	04	3-35
22.0203.0.000	04	3-39
22.0204.0.000	08	3-33
22.0204.0.000	48	3-37
22.0205.0.000	13	3-21
22.0206.0.000	17	3-33
22.0206.0.000	44	3-37
22.0207.0.000	17	3-33
22.0207.0.000	44	3-37
22.0210.0.050	08	3-21
22.0211.0.000	41	3-23
22.0214.0.000	28	3-19
22.0215.0.000	12	3-21
22.0216.0.000	12	3-35
22.0216.0.000	12	3-39
22.0219.0.000	03	3-33
22.0219.0.000	02	3-37

INDEX

PART NUMBER	DET	PAGE
22.0220.0.000		
22.0220.0.000	09	3-21
22.0225.0.000	01	3-21
22.0235.0.000	03	3-21
22.0270.0.000	14	3-53
22.0280.0.000	18	3-21
22.0300.0.000	13	3-29
22.0305.0.000	25	3-13
22.0309.0.000	37	3-13
22.0312.0.000	05	3-13
22.0313.0.000	29	3-13
22.0315.0.000	04	3-13
22.0320.0.000	27	3-13
22.0325.0.000	26	3-13
22.0336.0.000	11	3-13
22.0351.0.000	02	3-13
22.0353.0.000	09	3-13
22.0354.0.000	03	3-13
22.0370.0.000	10	3-13
22.0400.0.000	07	3-9
22.0401.0.000	05	3-11
22.0402.0.000	06	3-11
22.0403.0.000	01	3-5
22.0404.0.000	09	3-5
22.0405.0.000	09	3-9
22.0406.0.000	36	3-5
22.0406.1.000	26	3-45
22.0407.0.000	10	3-5
22.0408.0.000	24	3-29
22.0408.1.000	24	3-51
22.0500.0.000		
22.0500.0.000	19	3-3
22.0505.0.000	26	3-3
22.0506.0.000	24	3-3
22.0510.0.000	03	3-3
22.0520.0.000	06	3-3
22.0525.0.000	16	3-3
22.0530.0.000	10	3-3
22.0535.0.100	30	3-3
22.0540.0.000	14	3-3
22.0541.0.000	13	3-3
22.0542.0.000	11	3-3
22.0544.0.000	20	3-3
22.0545.0.000	22	3-3
22.1000.0.000		
22.1000.0.000	15	3-29
22.1010.0.000	03	3-17

PART NUMBER	DET	PAGE
22.1400.0.000		
22.1400.0.000	28	3-3
22.1405.0.000	04	3-23
22.1406.0.000	05	3-23
22.1415.0.050	06	3-23
22.1416.0.000	11	3-23
22.1422.0.000	10	3-27
22.1426.0.000	14	3-23
22.1430.0.000	07	3-23
22.1436.0.000	08	3-23
22.1442.0.000	12	3-23
22.1443.0.000	13	3-23
22.1973.0.000	21	3-33
22.1973.0.010	33	3-37
22.1974.0.000	21	3-33
22.1974.0.001	21	3-33
22.1974.0.002	21	3-33
22.1974.0.010	33	3-37
22.1974.0.011	33	3-37
22.1974.0.012	33	3-37
22.2034.0.000		
22.2034.0.000	56	3-47
22.2400.0.000	18	3-29
22.2410.0.000	01	3-15
22.2425.0.050	29	3-15
22.2440.0.000	03	3-15
22.2442.0.000	30	3-15
22.2600.0.000	11	3-25
22.2607.0.000	27	3-25
22.2607.0.000	26	3-43
22.2610.0.000	22	3-25
22.2610.0.000	21	3-43
22.2620.0.000	14	3-25
22.2622.0.000	12	3-25
22.2624.0.000	18	3-25
22.2626.0.000	25	3-25
22.2626.0.000	24	3-43
22.2627.0.000	26	3-25
22.2627.0.000	25	3-43
22.2630.0.000	15	3-25
22.2630.1.000	14	3-43
22.2631.0.000	7	3-25
22.2631.0.000	06	3-43
22.2633.0.000	8	3-25
22.2633.0.000	07	3-43
22.2635.0.000	19	3-25
22.2635.0.000	18	3-43
22.2637.0.000	13	3-25
22.2637.0.000	12	3-43

PART NUMBER	DET	PAGE
22.2638.0.000		
22.2638.0.000	17	3-25
22.2638.0.000	16	3-43
22.2639.0.000	16	3-25
22.2639.0.000	15	3-43
22.2640.0.050	4	3-25
22.2640.0.050	04	3-43
22.2645.0.000	6	3-25
22.2651.0.000	10	3-9
22.2652.0.000	11	3-9
22.2653.0.000	12	3-9
22.2655.0.000	05	3-9
22.2656.0.000	03	3-9
22.2657.0.000	02	3-9
22.2664.0.000	13	3-9
22.2665.0.000	08	3-9
22.3000.0.000		
22.3000.0.000	13	3-43
22.3001.0.000	11	3-43
22.3002.0.000	10	3-43
22.3010.0.000	17	3-43
22.3016.0.000	23	3-49
22.3022.0.000	49	3-51
22.3026.1.000	13	3-47
22.3027.1.000	16	3-47
22.3028.1.000	21	3-47
22.3029.1.000	27	3-47
22.3036.0.000	52	3-47
22.3037.0.000	18	3-45
22.3038.0.000	25	3-45
22.3039.0.050	24	3-45
22.3040.0.000	17	3-45
22.3041.0.000	19	3-45
22.3042.0.000	23	3-45
22.3043.0.000	20	3-45
22.3044.0.000	15	3-45
22.3045.0.000	12	3-45
22.3046.0.000	08	3-45
22.3047.0.000	51	3-45
22.3049.0.000	11	3-45
22.3050.0.000	48	3-45
22.3052.0.000	07	3-45
22.3053.0.000	06	3-45
22.3054.0.000	47	3-51
22.3055.0.000	27	3-51
22.3056.0.000	36	3-49
22.3057.0.000	34	3-49
22.3063.0.000	53	3-45

