



SERIES S104-100

EYELET BUTTONHOLE MACHINE

PARTS AND SERVICE MANUAL

PART NUMBER 97. 1400.0.002

This manual is valid from the machine serial No.: H 141610



**S-104-100 EYELET BUTTONHOLE MACHINE
PARTS & SERVICE MANUAL**

P/N 97.1400.0.003



**S-104-100 EYELET BUTTONHOLE MACHINE
PARTS & SERVICE MANUAL**

P/N 97.1400.0.003



**S-104-100 EYELET BUTTONHOLE MACHINE
PARTS & SERVICE MANUAL**

P/N 97.1400.0.003



**S-104-100 EYELET BUTTONHOLE MACHINE
PARTS & SERVICE MANUAL**

P/N 97.1400.0.003



**S-104-100 EYELET BUTTONHOLE MACHINE
PARTS & SERVICE MANUAL**

P/N 97.1400.0.003



**S-104-100 EYELET BUTTONHOLE MACHINE
PARTS & SERVICE MANUAL**

P/N 97.1400.0.003



SERIES S104-100

EYELET BUTTONHOLE MACHINE

PARTS AND SERVICE MANUAL

PART NUMBER 97. 1400.0.002

This manual is valid from the machine serial No.: H 141610



LIMITED WARRANTY ON NEW AMF REECE EQUIPMENT

Warranty provisions:

A ninety (90) day limited service labor warranty to correct defects in installation, workmanship, or material without charge for labor. This portion of the warranty applies to machines sold as "installed" only.

A one (1) year limited material warranty on major component parts to replace materials with defects. Any new part believed defective must be returned freight prepaid to AMF Reece, Inc. for inspection. If, upon inspection, the part or material is determined to be defective, AMF Reece, Inc. will replace it without charge to the customer for parts or material.

Service labor warranty period shall begin on the completed installation date. Material warranty shall begin on the date the equipment is shipped from AMF Reece, Inc.

Exclusions:

Excluded from both service labor warranty and material warranty are: (1) Consumable parts which would be normally considered replaceable in day-to-day operations. These include parts such as needles, knives, loopers and spreaders. (2) Normal adjustment and routine maintenance. This is the sole responsibility of the customer. (3) Cleaning and lubrication of equipment. (4) Parts found to be altered, broken or damaged due to neglect or improper installation or application. (5) Damage caused by the use of non-Genuine AMF Reece parts. (6) Shipping or delivery charges.

There is no service labor warranty for machines sold as "uninstalled".

Equipment installed without the assistance of a certified technician (either an AMF Reece Employee, a Certified Contractor, or that of an Authorized Distributor) will have the limited material warranty only. Only the defective material will be covered. Any charges associated with the use of an AMF Reece Technician or that of a Distributor to replace the defective part will be the customer's responsibility.

NO OTHER WARRANTY, EXPRESS OR IMPLIED, AS TO DESCRIPTION, QUALITY, MERCHANTABILITY, and FITNESS FOR A PARTICULAR PURPOSE, OR ANY OTHER MATTER IS GIVEN BY SELLER OR SELLER'S AGENT IN CONNECTION HEREWITH. UNDER NO CIRCUMSTANCES SHALL SELLER OR SELLER'S AGENT BE LIABLE FOR LOSS OF PROFITS OR ANY OTHER DIRECT OR INDIRECT COSTS, EXPENSES, LOSSES OR DAMAGES ARISING OUT OF DEFECTS IN OR FAILURE OF THE EQUIPMENT OR ANY PART THEREOF.

WHAT TO DO IF THERE IS A QUESTION REGARDING WARRANTY

If a machine is purchased through an authorized AMF Reece, Inc. distributor, warranty questions should be first directed to that distributor. However, the satisfaction and goodwill of our customers are of primary concern to AMF Reece, Inc. In the event that a warranty matter is not handled to your satisfaction, please contact the appropriate AMF Reece office:

Europe
Prostejov, Czech Republic
Phone: (+420) 582-309-286
Fax: (+420) 582-360-608
e-mail: amfreece@amfreece.cz

Warranty Registration Card

(Please Fax or Mail immediately after installation)

Note: All Warranty Claims Void, unless Registration Card on file at AMF Reece HQ

Machine model number:

(S101, S100, S104, S105, S311, Decostitch, S4000 BH, EBS Mark II, etc)

Manufacturer's serial or production number:

Installation Site Information:

Customer's Name:

Customer's Mailing Address:

Customer's Telephone Number:

Supervising Mechanic's or Technician's Name:

Signature of Supervising Technician:

AMF Reece Technician's Name:

AMF Reece Technician's Signature:

Type of garment produced at this location?

Average Daily Production Expected from this machine?

(number of buttonholes, jackets sewn, pants produced, buttons sewn, etc)

Any special requirements required at this location?

What other AMF Reece Machines are at this location?

How can we serve you better?

Tovární 837, 798 11 Prostějov, Czech Republic

Fax: +420 582 360 606, e-mail: service@amfreece.cz, website: www.amfreece.com

Revised 08/2011

e-mail: service@amfreece.cz ; parts@amfreece.cz ; website: www.amfreece.com

Phone: +420 582 309 286; Fax: +420 582 360 606

MACHINE MODELS

116	AF.CA.R.RE
122	AF.CB.R.FE
130	AF.CB/CA.R.RE
130W	AF.CB/CA.R.RE.WAISTBAND
133	CT.CA.5/8.RE
134	CT.CA.5/8.LE
135	CT.CA.3/4.RE
136	CT.CA.7/8.RE
137	CT.CB.3/4.RE
138	CT.CB.5/8.RE
139	CT.CB.7/8.RE
152	RDE
170	AF.CA.ST.RE.ADJ.CT
190	AF.CB/CA.R.FE

Abbreviation Definitions:

ADJ	= ADJUSTABLE	FE	= FRENCH EYE
AF	= ADJUSTABLE FLY	LE	= LARGE EYE
CA	= CUT AFTER	R	= REGULAR TRAVEL (7MM TO 1-1/4)
CB	= CUT BEFORE	RDE	= ROUND EYE
CB/CA	= CUT BEFORE / CUT AFTER	RE	= REGULAR EYE (7MM TO 1-1/4)
CT	= CORD TRIM	ST	= SHORT TRAVEL (1/2 TO 7/8)

Revised 08/2011

e-mail: service@amfreece.cz ; parts@amfreece.cz ; website: www.amfreece.com

Phone: +420 582 309 286; Fax: +420 582 360 606

TABLE OF CONTENTS

EQUIPMENT FAMILIARIZATION	1-1
TABLE SET-UP AND ROTATION CHECK	1-2
BELT TENSION ADJUSTMENTS	1-3
COLOURED MARKING ON THE MACHINE	1-4
THREAD STAND INSTALLATION	1-5
LUBRICATION	1-6
MACHINE OPERATION	
THREADING THE MACHINE	1-8
STARTING THE MACHINE	1-10
BUTTONHOLE QUALITY FEATURS	1-11
PRINCIPLES OF SEWING	1-12
ADJUSTMENTS	
STOP MOTION ADJUSTMENTS	1-18
SLIT CLUTCH ADJUSTMENTS	1-37
RACE ADJUSTMENTS	1-38
ADJUSTABLE FLYBAR PINS SETTING - NO EYE	1-43
LOOPER AND NEEDLE ALIGNMENT	1-45
PRICK-IN	1-46
EYESHAPe ADJUSTMENT	1-48
CUTTING SPACE ADJUSTMENT	1-49
STITCH BITE WIDTH ADJUSTMENT	1-50
BUTTONHOLE LENGTH ADJUSTMENT	1-51
FLYBAR ADJUSTMENT	1-52
END STITCH ADJUSTMENT	1-53
STITCH COUNT ADJUSTMENT	1-54
CUTTING STEEL AND KNIFE ADJUSTMENT	1-55
CLAMPING	1-59
LOOPERS AND SPREADERS	1-72
UPPER TENSION THREAD RELEASE	1-77
TRIM KNIFE ADJUSTMENT	1-78
CORD TRIM ADJUSTMENTS	1-80

Revised 08/2011

e-mail: service@amfreece.cz ; parts@amfreece.cz ; website: www.amfreece.com

Phone: +420 582 309 286; Fax: +420 582 360 606

TABLE OF CONTENTS (Cont'd)

SELECTING CUT BEFORE (CB) OR CUT AFTER (CA)	1-90
PREVENTIVE MAINTENANCE	1-91
RECOMMENDED SPARE PARTS	1-92
NEEDLES	1-93
KNIVES AND CUTTING STEELS	1-94

EQUIPMENT FAMILIARIZATION

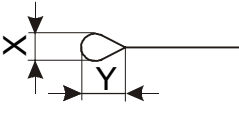
Description	Eyelet Buttonhole Sewing Machine
Sewing Speed	Up to 1,900 spm
Stitch Type	401 two thread chainstitch
Stitch Density	3 to 16 s/cm (7 to 40 spi)
Buttonhole Length	13 to 32 mm (1/2" to 1 1/4")
Automatic Cutting Length	N/A
Eye Shape (X; Y) mm	No Eye; 2,7 x 4,3
	
End Shape	flibar, open end
Stitch Bite	2 to 4 mm
Automatic Thread Trimming	AF - top thread only
Lubrication	Semi - automatic wicking system
Electrical Supply	230V, 50/60Hz, 3 Ph 400V, 50/60Hz, 3Ph 230V, 50/60Hz, 1Ph 110V 60Hz 1Ph
Dimensions (crated)	
Sewing Head	
Length	79 cm (31")
Width	64 cm (25")
Height	80 cm (31 1/2")
Weight	89 kg (196 lbs)
Table	
Length	114 cm (45")
Width	68 cm (27")
Height	40 cm (16")
Weight	69 kg (152 lbs)
Overall Dimensions	
Floor Plan	110 x 60 cm (43" x 24")
Table Height	70 cm (27 1/2") adjustable to 90 cm (35")

Revised 09/2004

e-mail: service@amfreece.cz; parts@amfreece.cz; website: www.amfreece.com

Phones: +420 582 309 146 (Service), +420 582 309 286 (Spare Parts); Fax: +420 582 360 606

TABLE SET-UP AND ROTATION CHECK

1. Unpack the table, connect electrical plug, and turn the main power on.
2. Make sure the left hand motor pulley rotates counterclockwise. Once this has been done, turn the main power off.
3. Place the rubber cushions **1** onto the top surface of the table.
4. Unpack the machine and set it on the table, lining the machine up with the four larger holes. Be sure to lift the machine by the base.

CAUTION: Do not lift the machine by the bedplate.

5. Place the machine **2** on rubber cushions **1**, screw the screws **3**, insert the cushions under them.

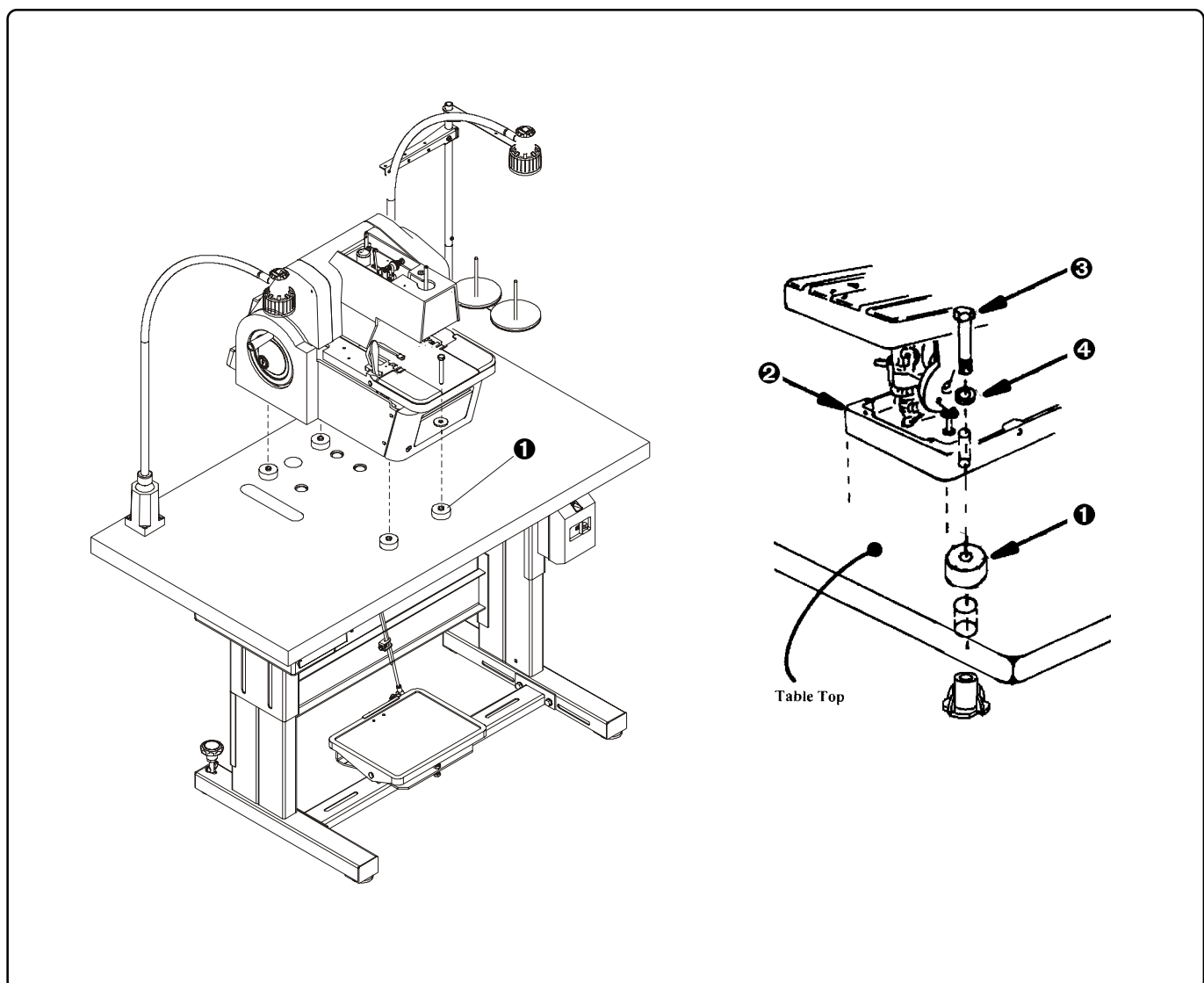

Revised 09/2004

BELT TENSION ADJUSTMENTS

BELT TENSION ASSEMBLY AND ADJUSTMENT

CAUTION: According to electrical power frequency is necessary to use the motor pulley ④ 50Hz or 60Hz. (If the motor rotations are higher then is recommended by the manufacturer, the machine can get damaged)

1. Remove the belt cover ① and the base ② . Put V-belt ③ on the pulley ④ and over the hole in stand plate on motor pulley ⑤ .
2. Loose the nut ⑥ and turn the motor ⑦ tighten the belt.
3. Check the tightening with 30N pressure. Belt sag should be around 20 mm.
4. Make sure pulley rotates counterclockwise.
5. Install belt ① and base ② covers.

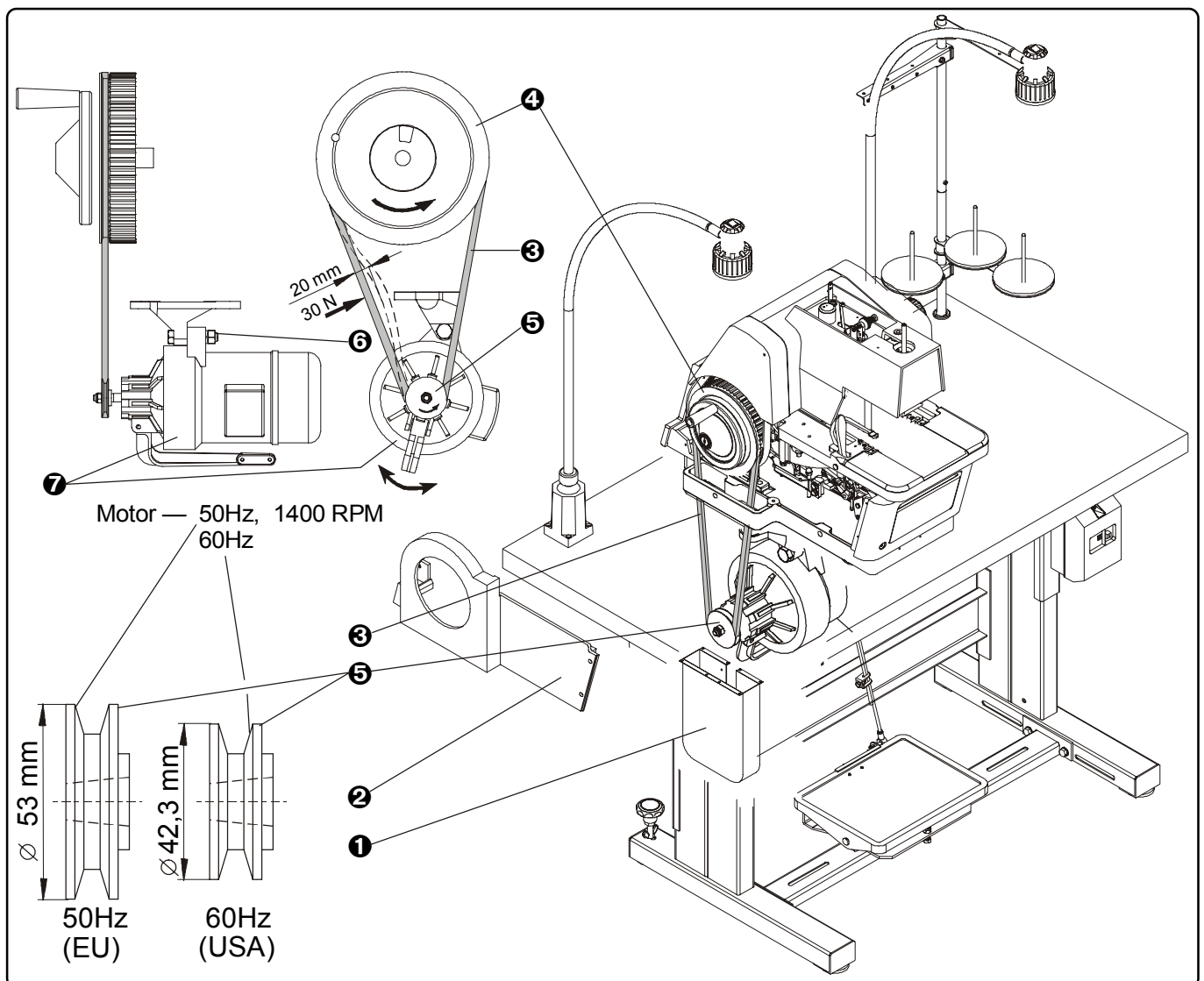

Revised 09/2004

e-mail: service@amfreece.cz; parts@amfreece.cz; website: www.amfreece.com

Phones: +420 582 309 146 (Service), +420 582 309 286 (Spare Parts); Fax: +420 582 360 606

COLOURED MARKING ON THE MACHINE

COLOURED MARKING

- Screw - top links: **Yellow marks** — 1. Loosing and following disassembly of this link causes distinctive intervention to the mechanism adjustment, that was done when assembled and sewed off at the factory.
2. After such an intervention to the mechanism, new adjustment of set mechanism needs to be done and complete check of whole machine adjustment as well.
- Blue marks** — Screws and nuts secured against loosing with glue „LOCTITE”.
- Lubrication locations: **Red marks** — **Caution:** *Lubrication regime adherence is necessary for protection of the reliable long-term machine operation.*

THREAD STAND INSTALLATION

THREAD STAND INSTALLATION

1. Put the thread stand together according to the drawing.
2. Position of the locking ring **1** allows assembly of the thread stand for various thickness of the table top. Threaded end of the post **6** must not extend more that 1 mm (1/32") through the locking nut **5**.
3. Insert the washer **2** and the post into the hole provided in the right rear of the table top **3**. Insert the washer **4** and tighten the nut **5**.

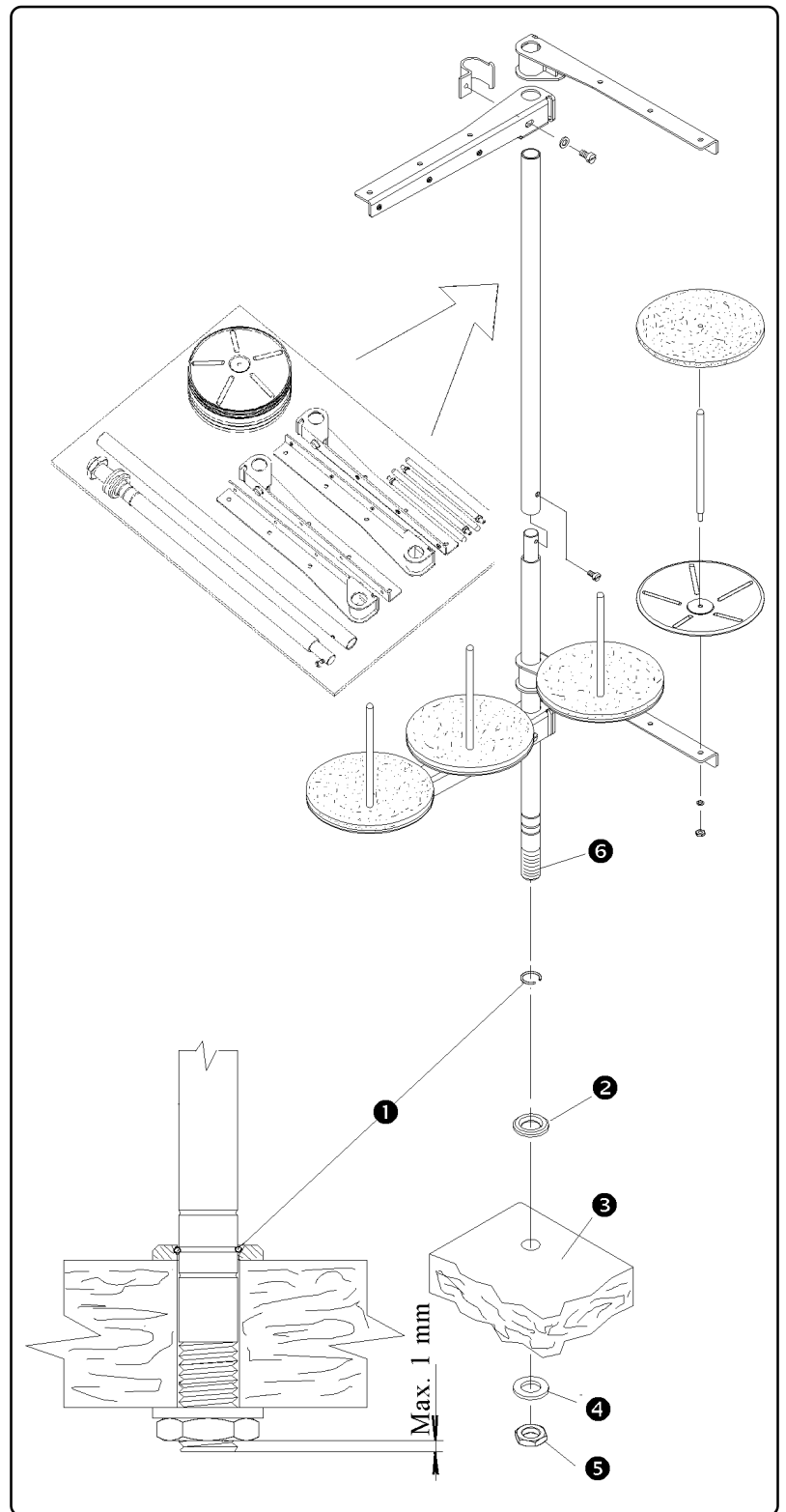

Revised 09/2004

e-mail: service@amfreece.cz; parts@amfreece.cz; website: www.amfreece.com

Phones: +420 582 309 146 (Service), +420 582 309 286 (Spare Parts); Fax: +420 582 360 606

LUBRICATION

1. Oil tank **1** , which is located on the top of the edge on the head, should be checked daily. It is supposed to be full at the beginning of each day.
2. Red marked places, pertinently the places with sticker with OIL description, must be regularly checked and lubricated, after every 30 hours of operating as of minimal. (*More often when necessary.*)
3. Let the machine cycle 20 times or more , so all excess oil can be removed.
4. Recommended lubricating oil TERESSTIC 68

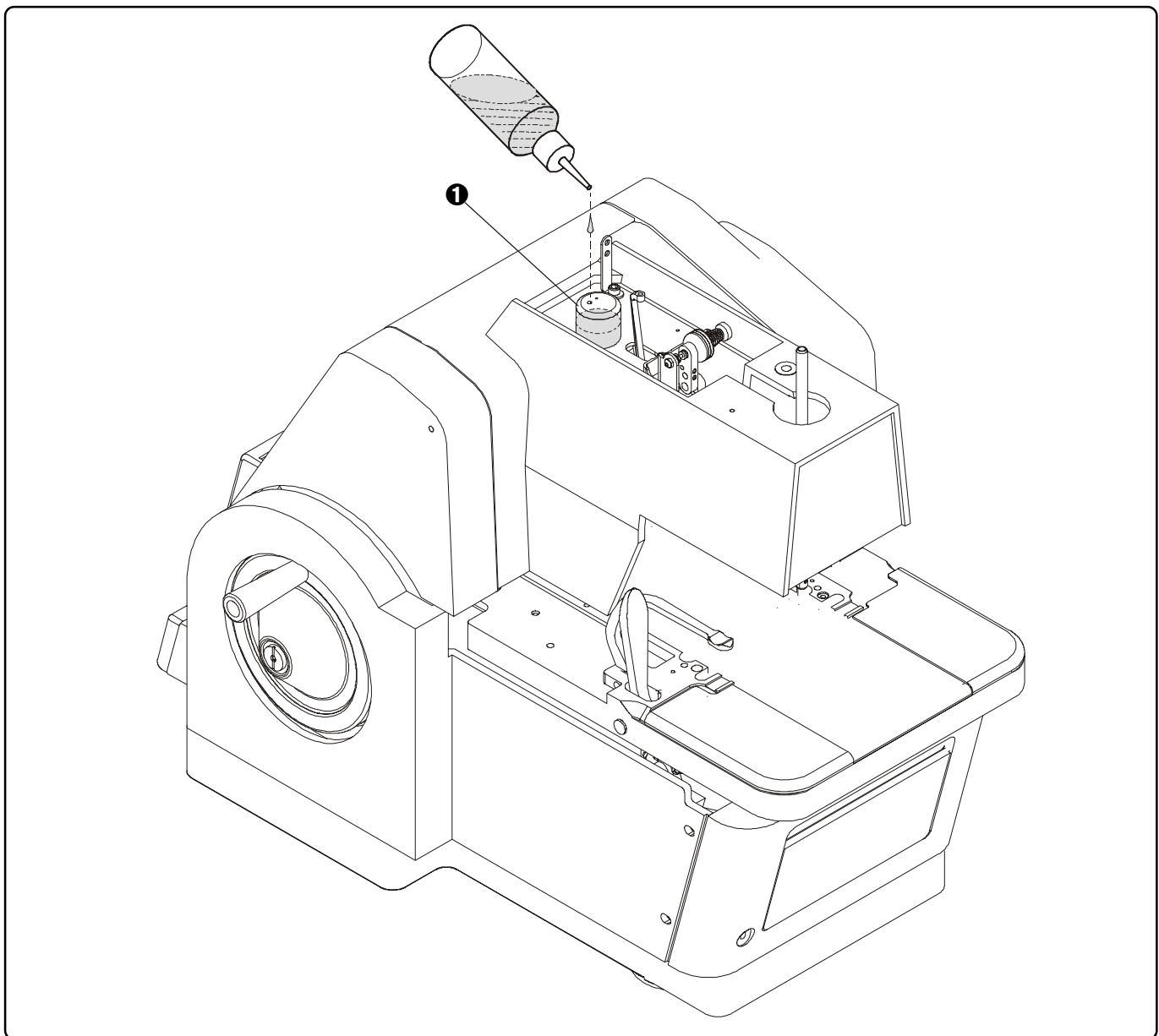

Revised 09/2004

e-mail: service@amfreece.cz; parts@amfreece.cz; website: www.amfreece.com

Phones: +420 582 309 146 (Service), +420 582 309 286 (Spare Parts); Fax: +420 582 360 606

LUBRICATION

SCHEME OF THE LUBRICATION DISTRIBUTION

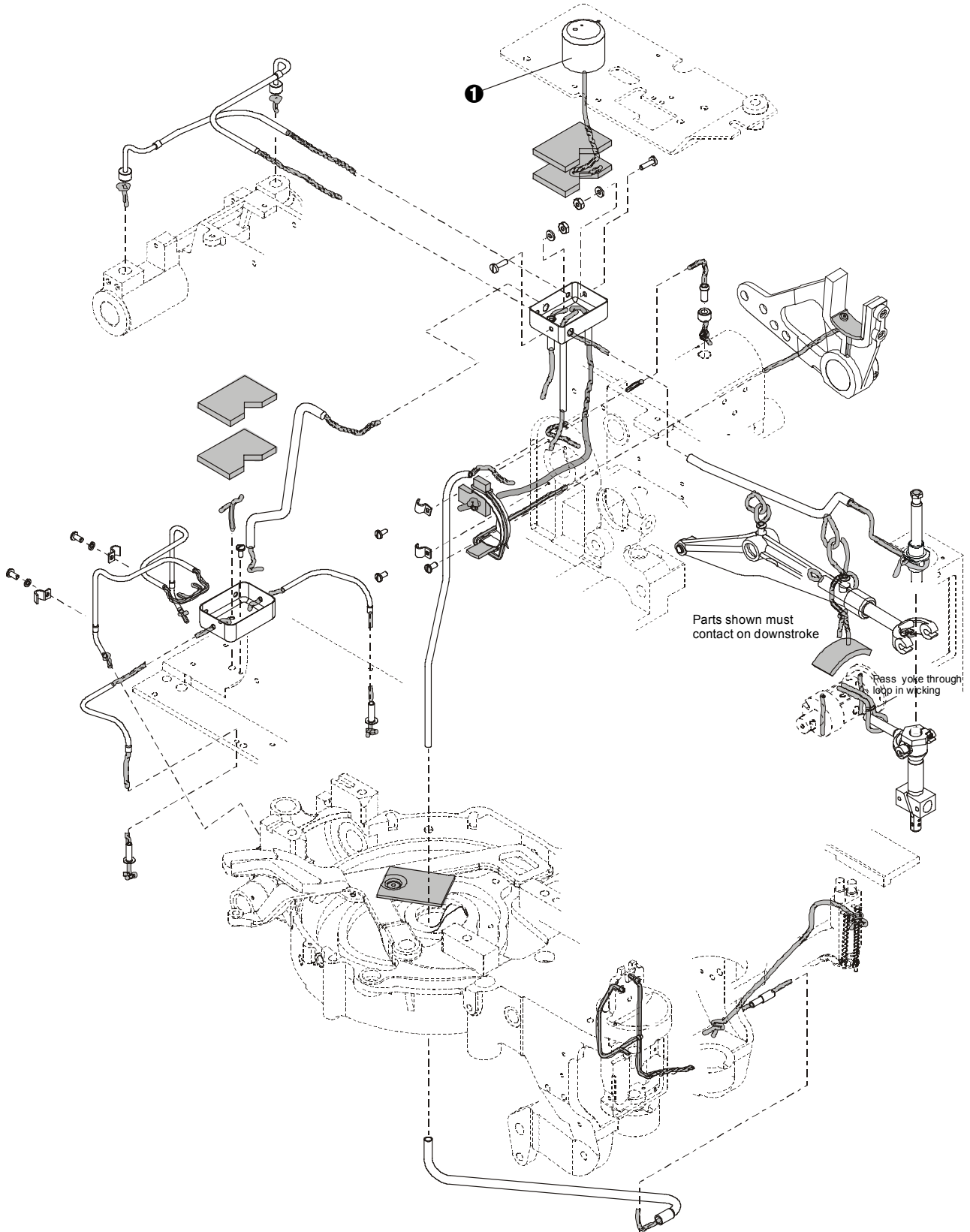

Revised 09/2004

e-mail: service@amfreece.cz; parts@amfreece.cz; website: www.amfreece.com

Phones: +420 582 309 146 (Service), +420 582 309 286 (Spare Parts); Fax: +420 582 360 606

MACHINE OPERATION

Threading the Machine

1. Make sure the power is turned OFF.
2. Turn the left hand crank through a cycle until the race is facing the rear of the machine.
3. Thread gimp A as shown below.

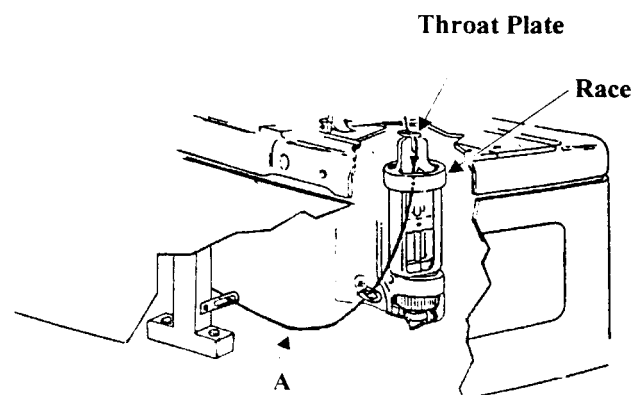
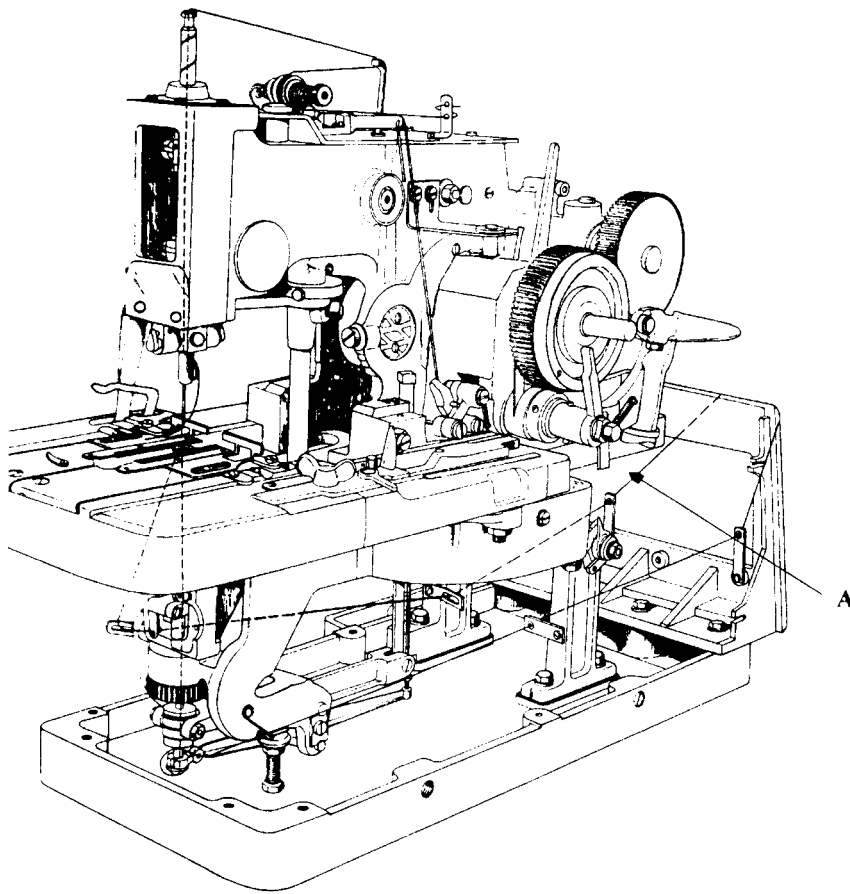

Revised 09/2004

e-mail: service@amfreece.cz; parts@amfreece.cz; website: www.amfreece.com

Phones: +420 582 309 146 (Service), +420 582 309 286 (Spare Parts); Fax: +420 582 360 606

MACHINE OPERATION

4. Thread top thread **B** as shown below.

5. Continue turning the left hand crank until the race faces the front of the machine. Thread bottom thread **C** as shown below.

Use T-20 threading wire for threading
needle and looper spindle

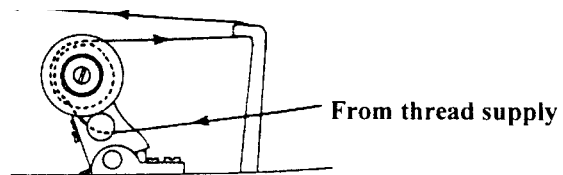

NOTE: Thread makes 1 1/2 turns around the roller

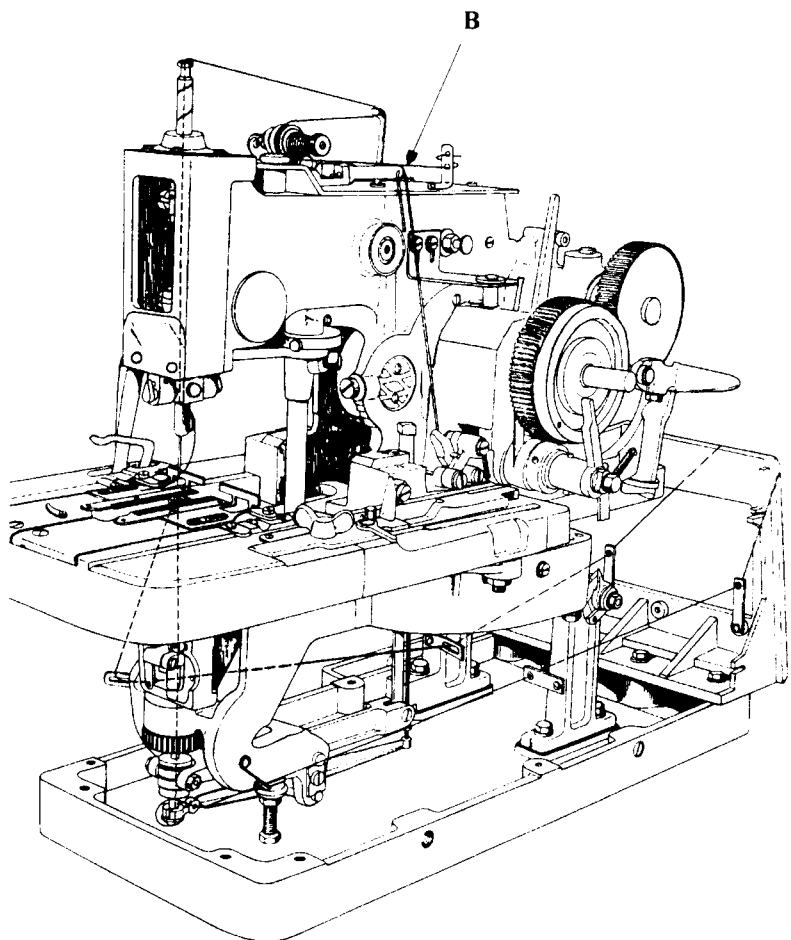
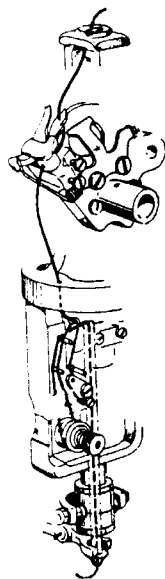
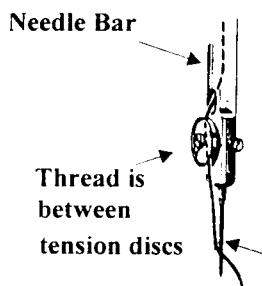

Revised 09/2004

e-mail: service@amfreece.cz; parts@amfreece.cz; website: www.amfreece.com

Phones: +420 582 309 146 (Service), +420 582 309 286 (Spare Parts); Fax: +420 582 360 606

MACHINE OPERATION

Starting the Machine

It is recommended that 20 buttonholes be sewn on a scrap piece of material before sewing on a garment. Doing this will remove all the oil and grease from the upper and lower tensions.

1. Place sewing work under clamp feet **A**. Pull hand clamping lever **B** forward. Clamp feet **A** will move down and hold sewing work in place.

2. Turn main power switch **C** on, and push down on the back of the foot pedal located on the treadle rail of the table stand. By doing this the power will be turned on and the brake will be released. Push down on starting lever **D**, this will start the machine sewing. **DO NOT TRY TO HOLD OR MOVE THE SEWING WORK WITH YOUR HANDS.** After the machine has stopped, remove the sewing work from under clamp feet **A**.

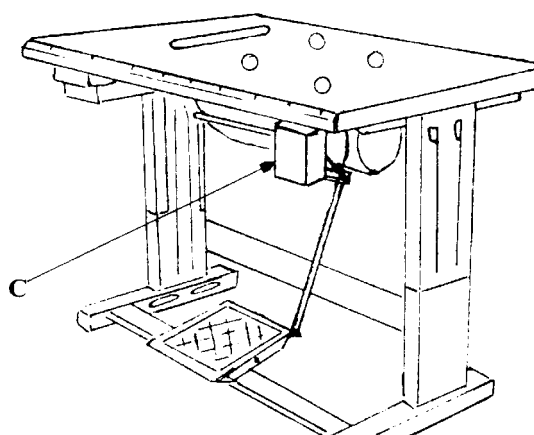
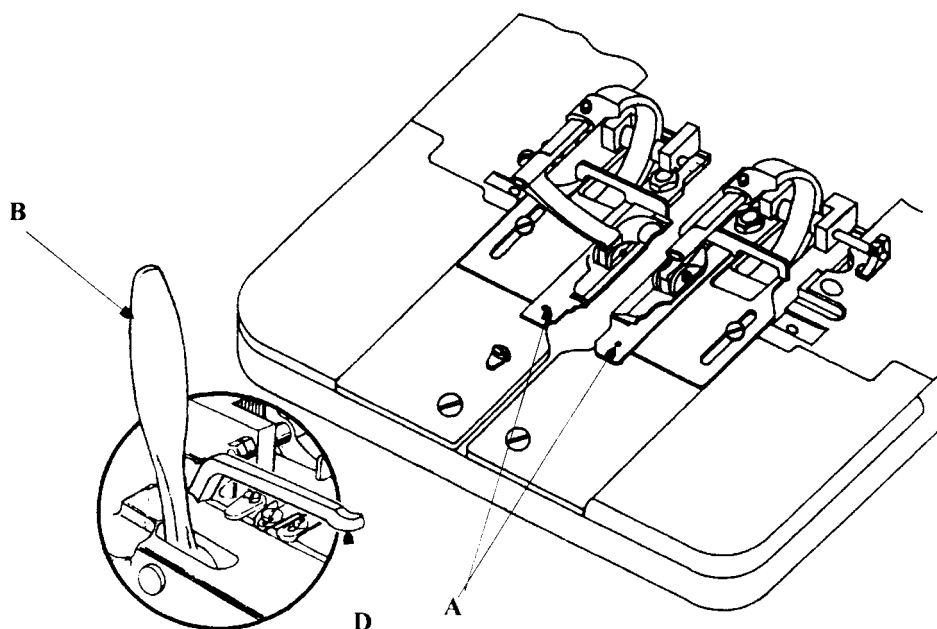

Revised 09/2004

e-mail: service@amfreece.cz; parts@amfreece.cz; website: www.amfreece.com

Phones: +420 582 309 146 (Service), +420 582 309 286 (Spare Parts); Fax: +420 582 360 606

BUTTONHOLE QUALITY FEATURES

The perfect buttonhole will feature:

- Uniform stitching.
- Consistent purl formation.
- Symmetrical eye shape.
- Proportional shape and size.
- Tacked/trimmed.

WHAT TO LOOK FOR

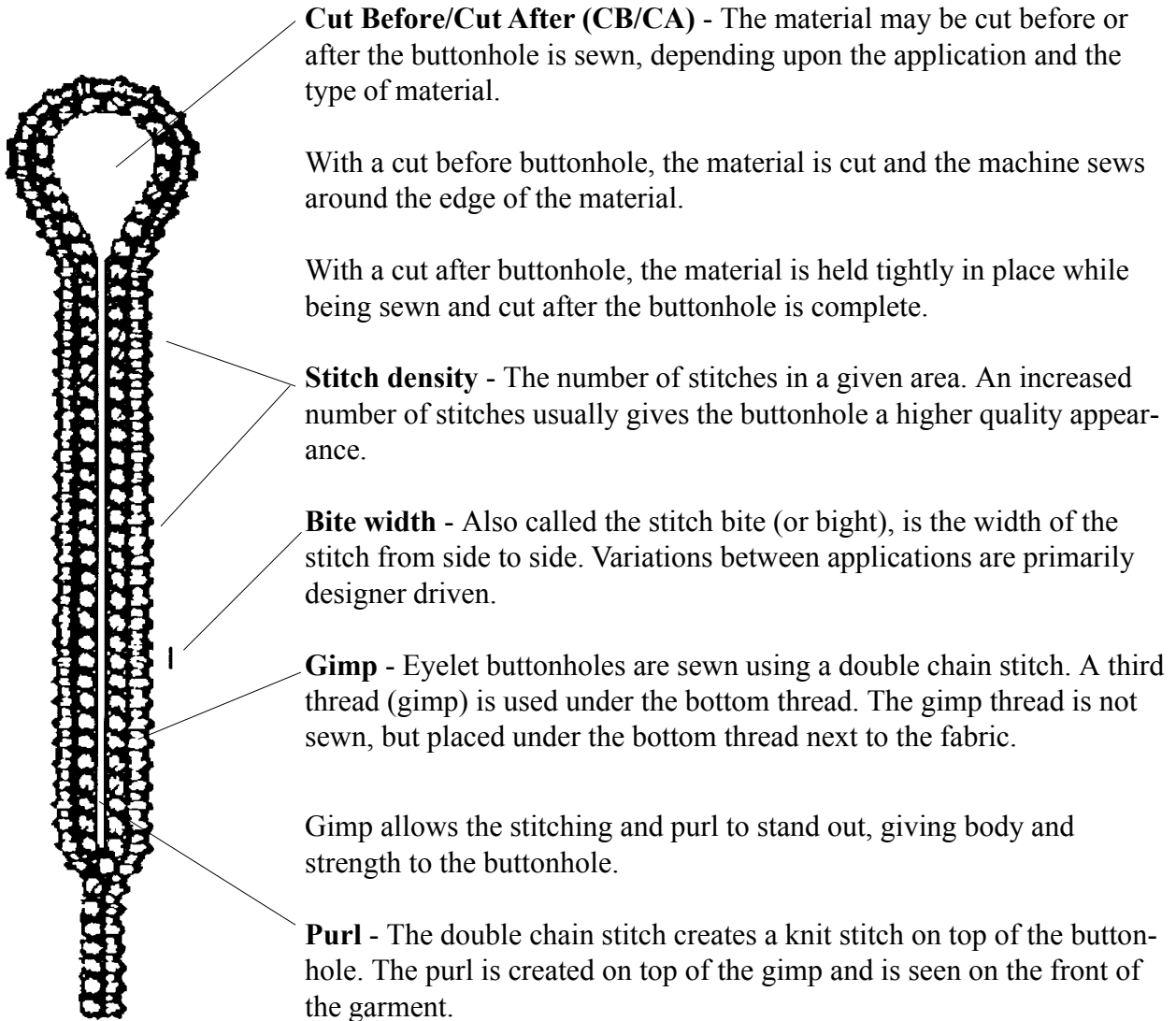

Cut Before/Cut After (CB/CA) - The material may be cut before or after the buttonhole is sewn, depending upon the application and the type of material.

With a cut before buttonhole, the material is cut and the machine sews around the edge of the material.

With a cut after buttonhole, the material is held tightly in place while being sewn and cut after the buttonhole is complete.

Stitch density - The number of stitches in a given area. An increased number of stitches usually gives the buttonhole a higher quality appearance.

Bite width - Also called the stitch bite (or bight), is the width of the stitch from side to side. Variations between applications are primarily designer driven.

Gimp - Eyelet buttonholes are sewn using a double chain stitch. A third thread (gimp) is used under the bottom thread. The gimp thread is not sewn, but placed under the bottom thread next to the fabric.

Gimp allows the stitching and purl to stand out, giving body and strength to the buttonhole.

Purl - The double chain stitch creates a knit stitch on top of the buttonhole. The purl is created on top of the gimp and is seen on the front of the garment.

Revised 09/2004

e-mail: service@amfreece.cz; parts@amfreece.cz; website: www.amfreece.com

Phones: +420 582 309 146 (Service), +420 582 309 286 (Spare Parts); Fax: +420 582 360 606

PRINCIPLES OF SEWING

A stitch is the unit of thread formed in the production of seams and stitching.

Stitching is defined as a series of stitches embodied in a material for ornamental purposes, for finishing an edge, or both.

The type of stitch used in the eyelet buttonhole machine is a two-thread, chain lock, purl stitch enveloping a reinforcing cord. When the thread, loopers, and spreaders create a buttonhole:

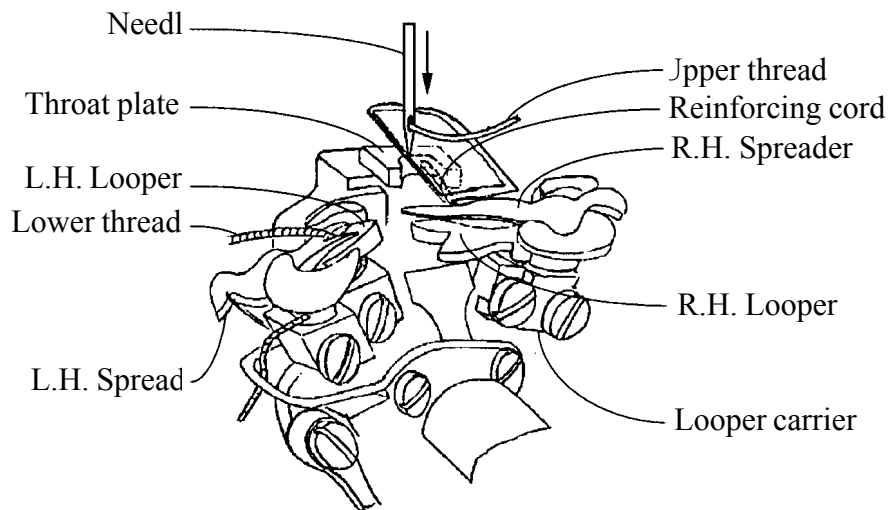

The needle lifts up and forms a loop. The looper carrier moves to the right and the left-hand looper enters the loop formed.

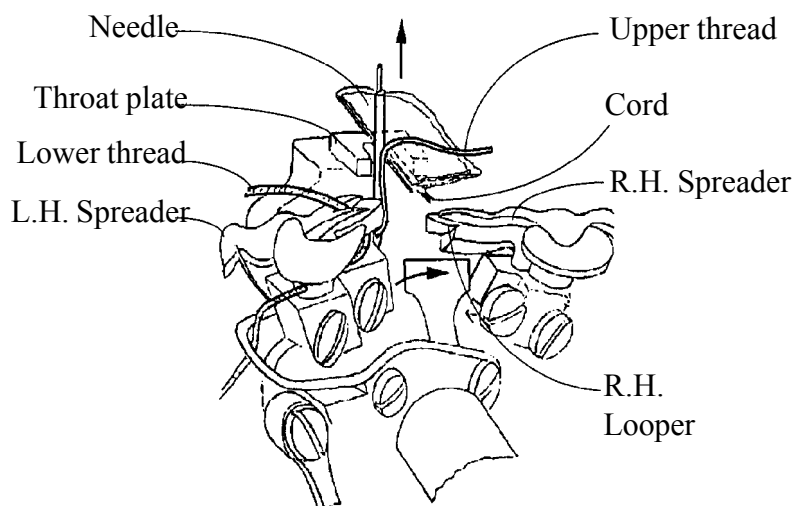

Revised 09/2004

e-mail: service@amfreece.cz; parts@amfreece.cz; website: www.amfreece.com

Phones: +420 582 309 146 (Service), +420 582 309 286 (Spare Parts); Fax: +420 582 360 606

PRINCIPLES OF SEWING

The looper carrier continues moving to the right, carrying the lower thread, the left-hand looper, and the spreader, fully into the loop formed.

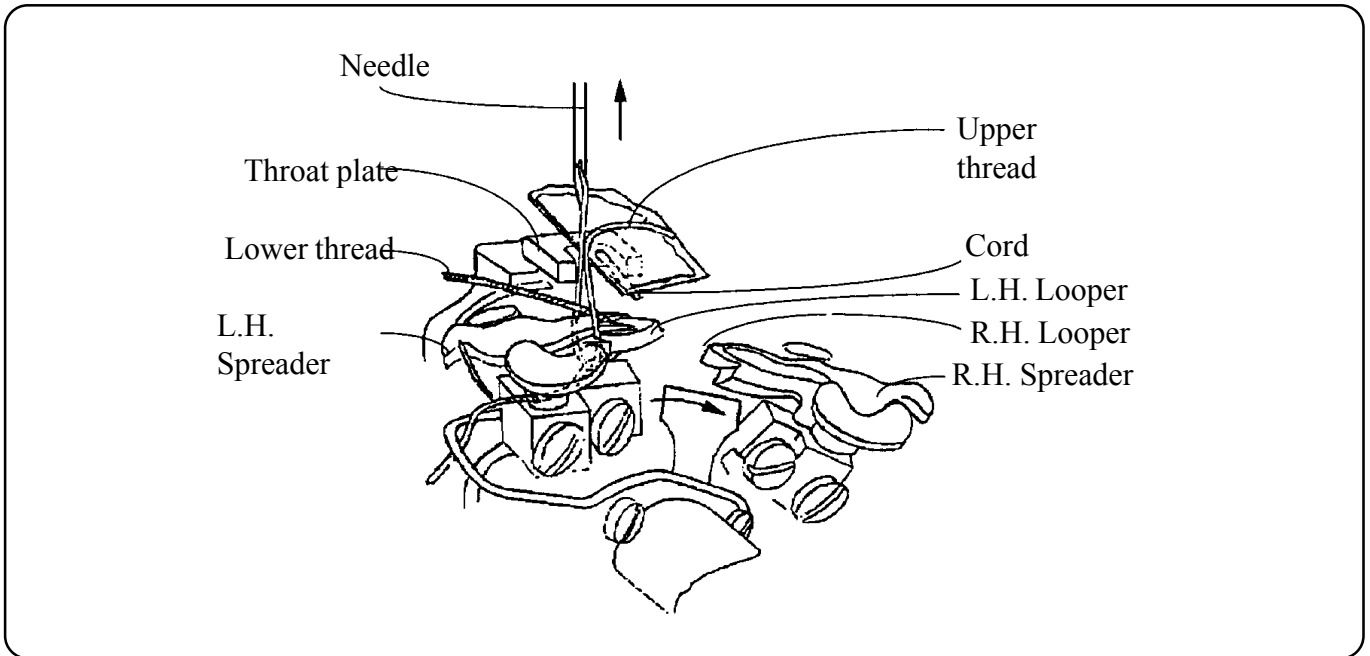

The left-hand spreader opens, making room for the needle to pass through the loop formed by the lower thread. This penetration, allows the needle to encompass the cord.

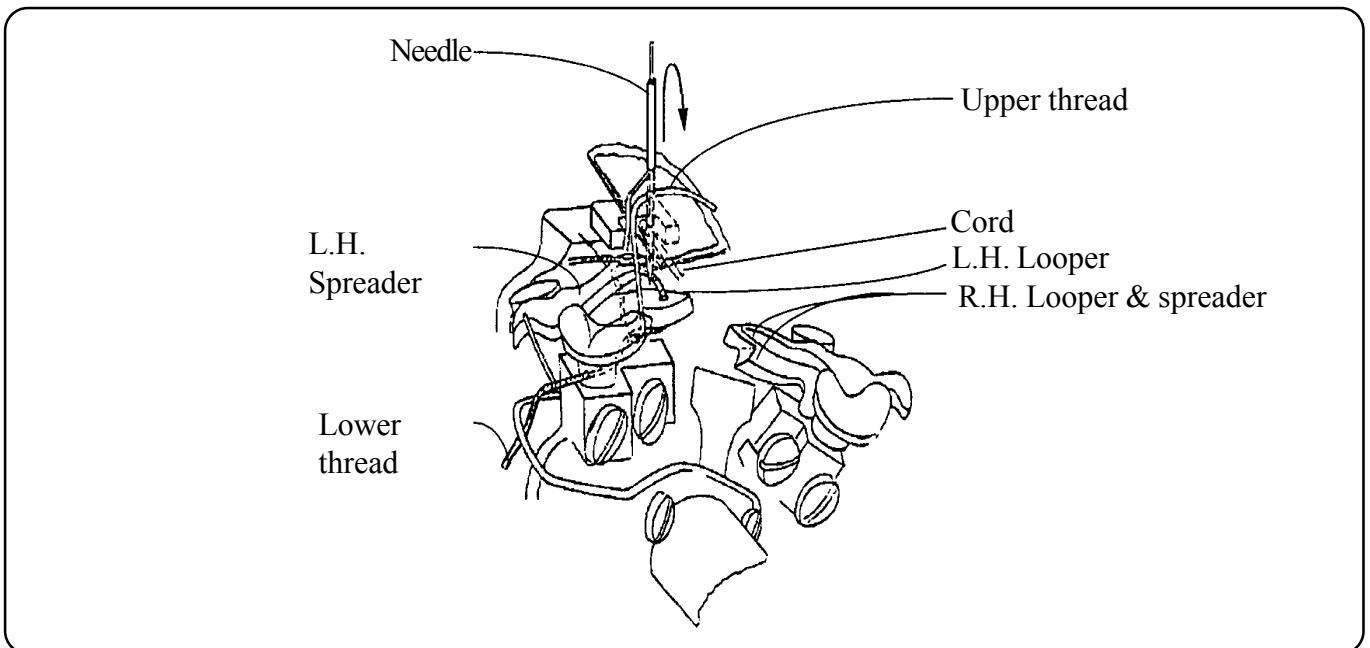

Revised 09/2004

e-mail: service@amfreece.cz; parts@amfreece.cz; website: www.amfreece.com

Phones: +420 582 309 146 (Service), +420 582 309 286 (Spare Parts); Fax: +420 582 360 606

PRINCIPLES OF SEWING

As the needle moves down to form a new loop, an implement called a take-up, pulls the upper thread up and into the material, bringing along the lower thread.

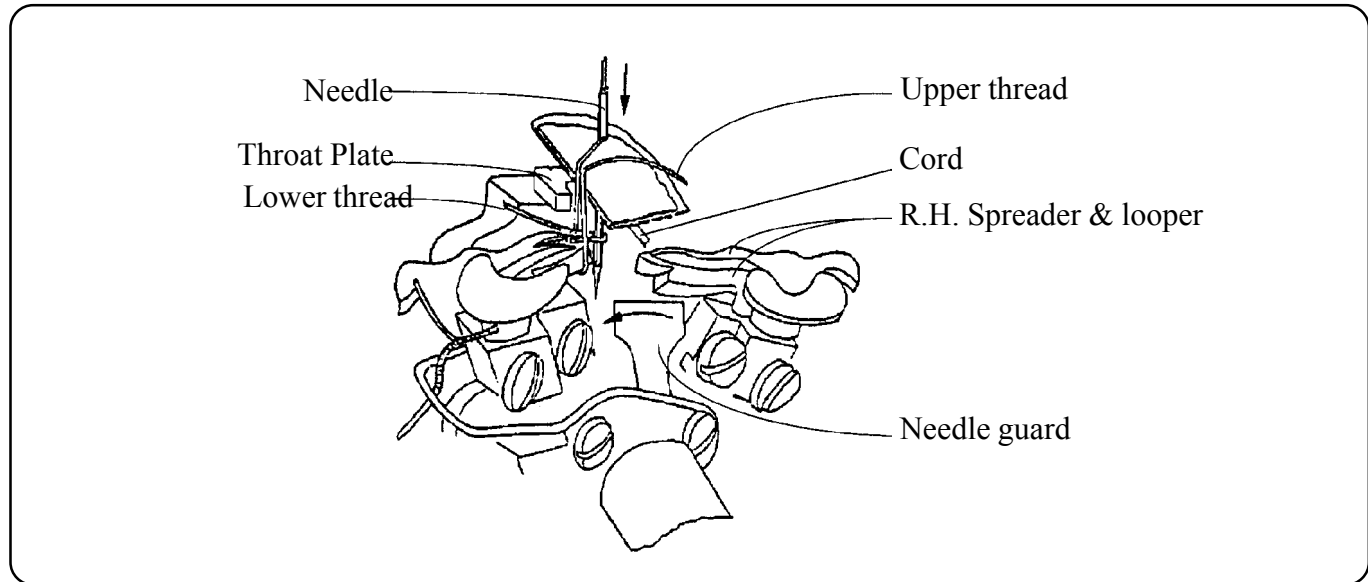

A loop is formed as the needle rises. The looper carrier continues moving to the left and the right-hand looper enters the new loop formed. The previous loop is pulled up tight against the material.

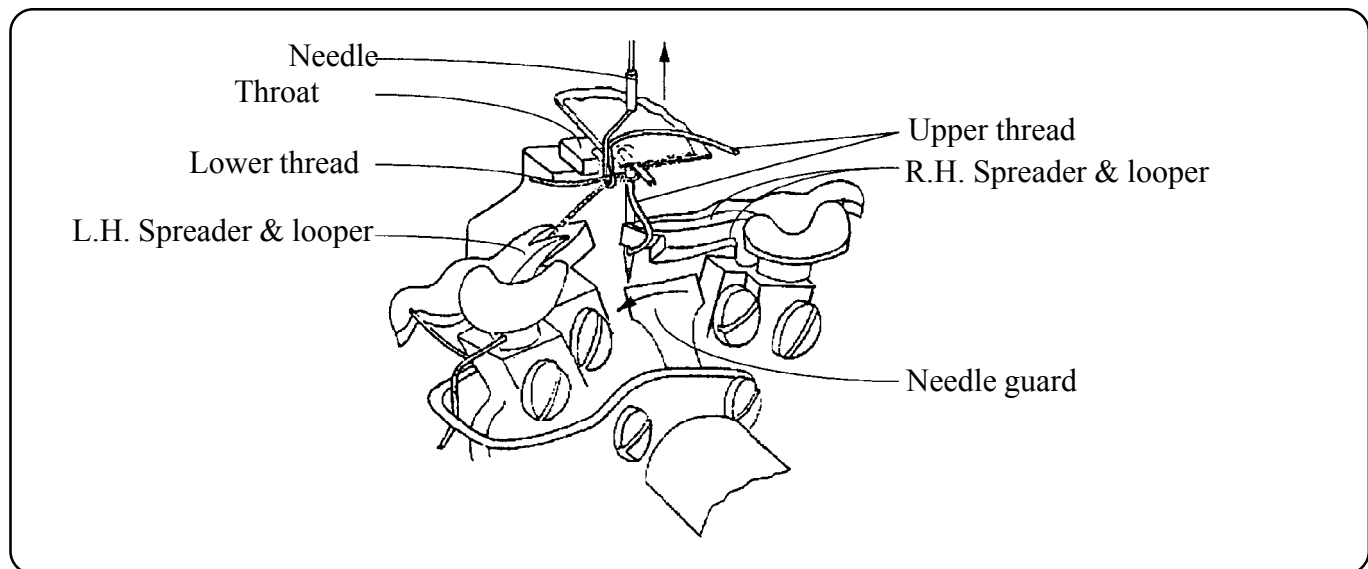

Revised 09/2004

e-mail: service@amfreece.cz; parts@amfreece.cz; website: www.amfreece.com

Phones: +420 582 309 146 (Service), +420 582 309 286 (Spare Parts); Fax: +420 582 360 606

PRINCIPLES OF SEWING

The looper carrier continues moving to the left. The right-hand looper and spreader fully enter the loop formed.

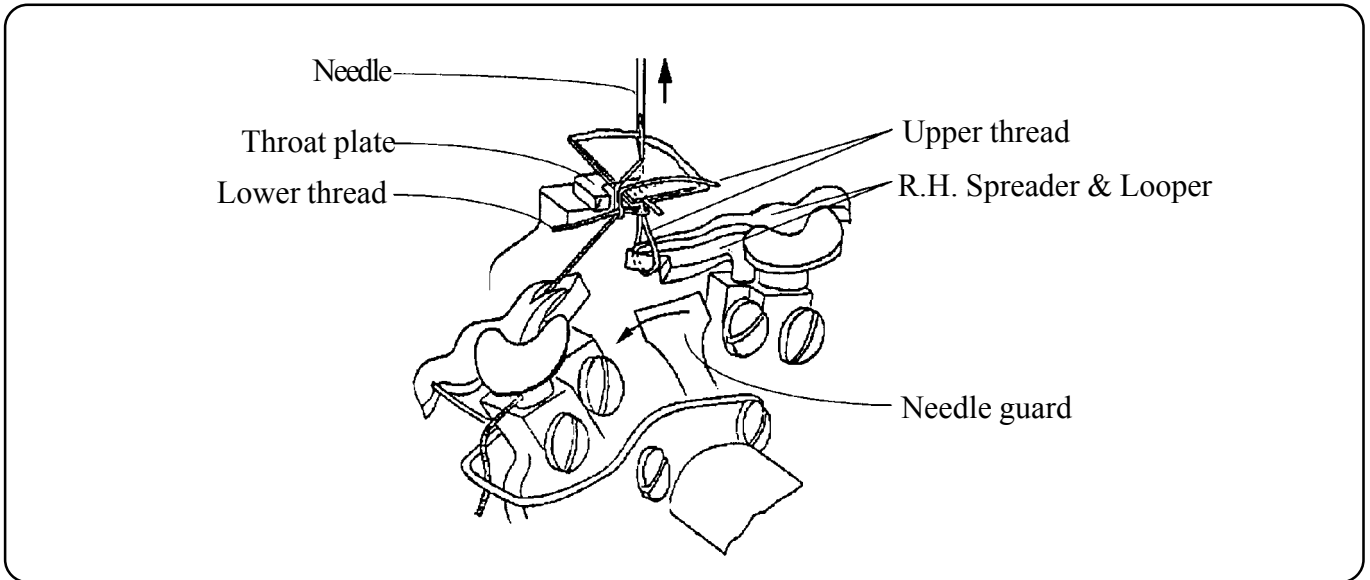

The right-hand spreader opens, making room for the needle to pass through a loop formed by the upper thread.

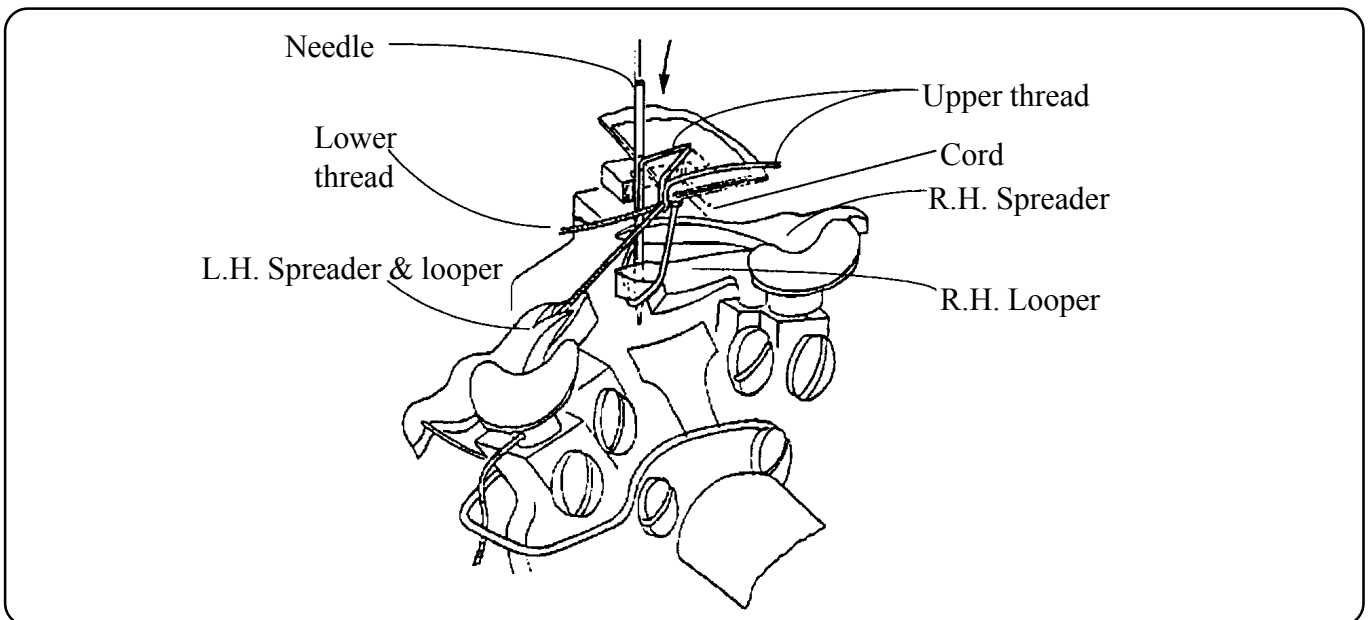

Revised 09/2004

e-mail: service@amfreece.cz; parts@amfreece.cz; website: www.amfreece.com

Phones: +420 582 309 146 (Service), +420 582 309 286 (Spare Parts); Fax: +420 582 360 606

PRINCIPLES OF SEWING

The looper carrier moves to the right as the needle “strips” the loop previously formed. The left-hand looper enters the new loop being formed.

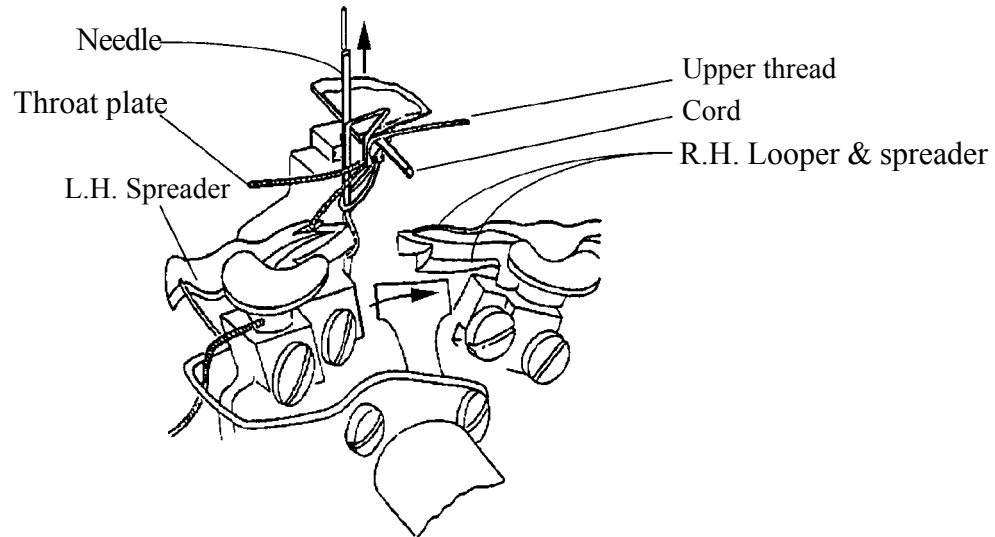

The lower thread forms a purl and along with the previously formed thread loop, is pulled up against the material. The enveloped cord provides body to the buttonholes.

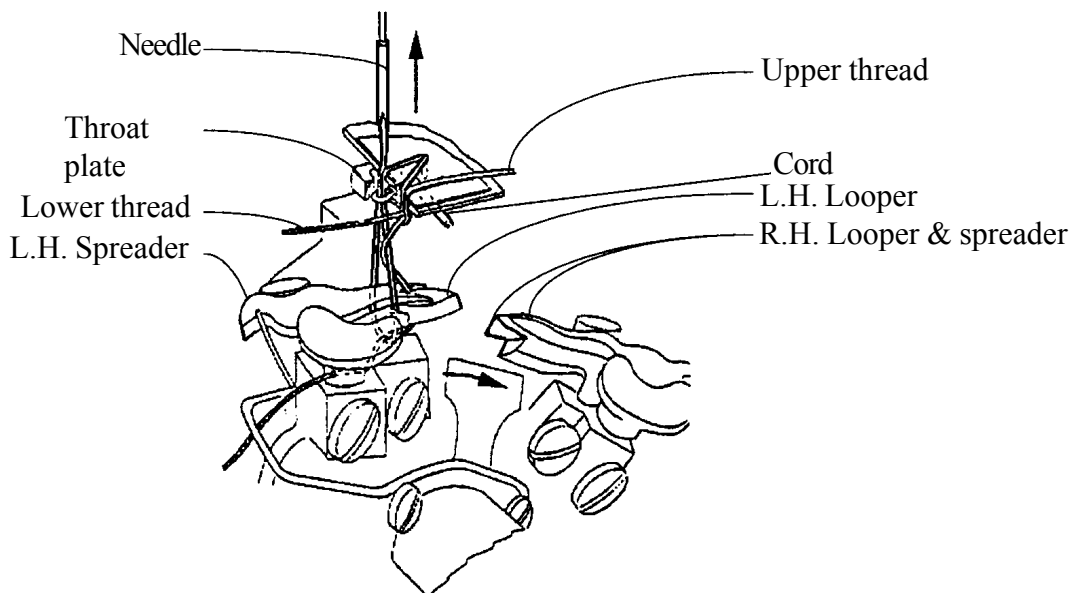

Revised 09/2004

e-mail: service@amfreece.cz; parts@amfreece.cz; website: www.amfreece.com

Phones: +420 582 309 146 (Service), +420 582 309 286 (Spare Parts); Fax: +420 582 360 606

PRINCIPLES OF SEWING

The AMF Reece two-thread, chain lock, purl stitch with reinforcing cord.

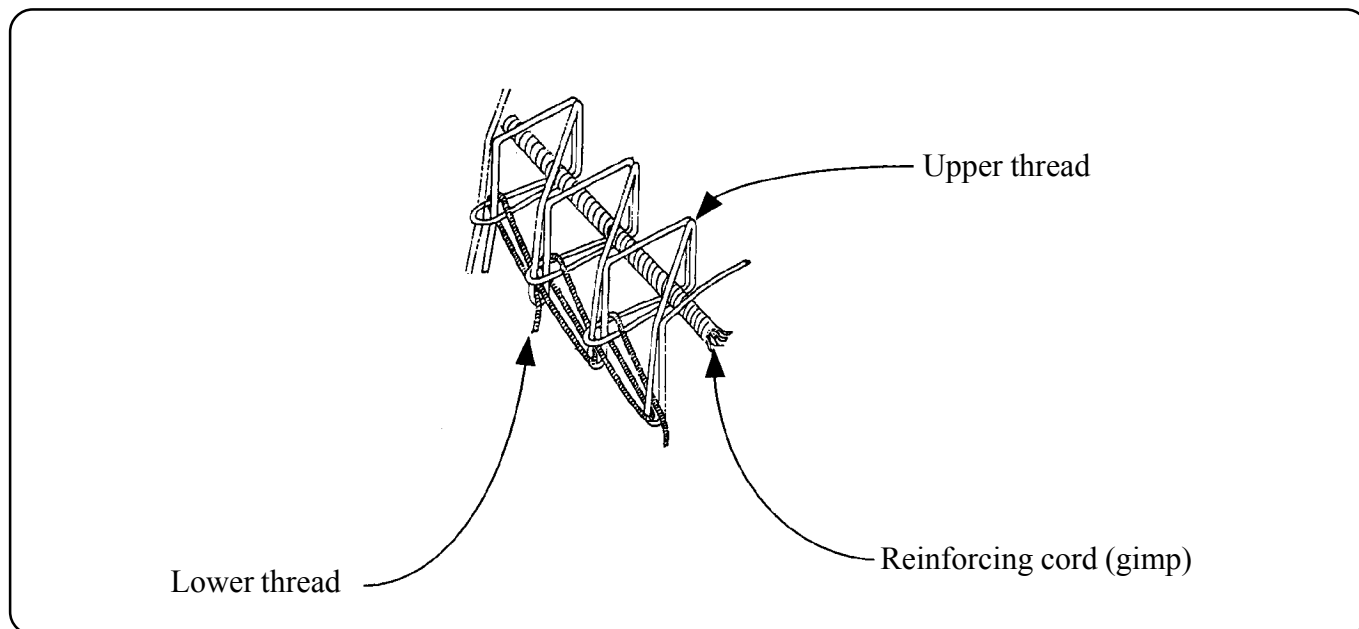

Revised 09/2004

e-mail: service@amfreece.cz; parts@amfreece.cz; website: www.amfreece.com

Phones: +420 582 309 146 (Service), +420 582 309 286 (Spare Parts); Fax: +420 582 360 606

STOP MOTION ADJUSTMENTS

The majority of adjustments are started when the machine is in the home position. The home position is reached by turning the left hand crank slowly through a cycle. Halfway through the cycle, the bedplate will start moving towards the rear of the machine. Once the bedplate has stopped moving to the rear, it is in home position. It is recommended that every time the machine is brought to the home position that the right hand stop wheel be locked. This is done by turning the wheel counterclockwise.

There are two different types of stop motions: roller controlled and flyover lever. There are definite advantages to the newer roller controller model:

- softer, more positive stops
- fewer adjustments
- less down time

A conversion kit, P/N 03.5361.0.000, may be purchased to convert the flyover lever to roller controlled.

NOTE: Before performing the following adjustments, ensure that the needle and the left hand lower drive belt have been removed.

Ensure you use the correct stop motion procedures for your style machine.

Roller Controlled Stop Motion

When setting this stop motion, the CB/CA style machines must be set in the CA mode (see page 1-92).

1. Make sure main power is off.
2. Turn left hand crank **A** until the machine is in the home position. Once in the home position, turn the right hand stop wheel **B** counterclockwise until it locks.

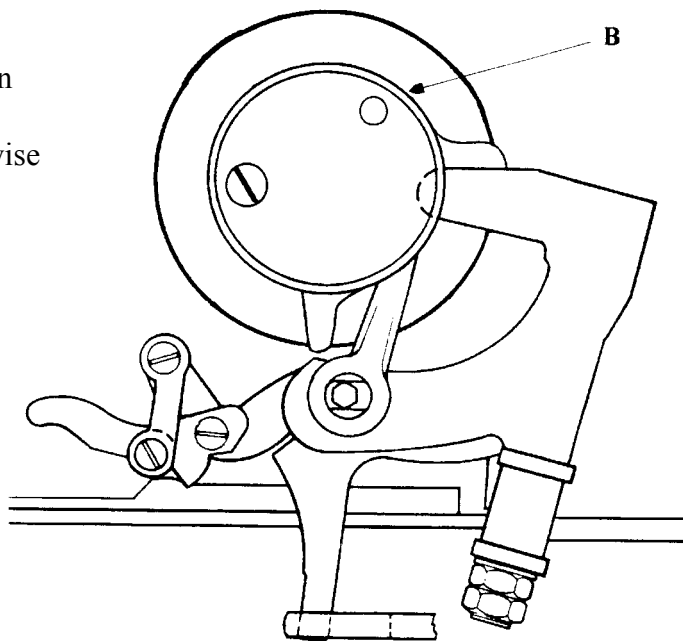
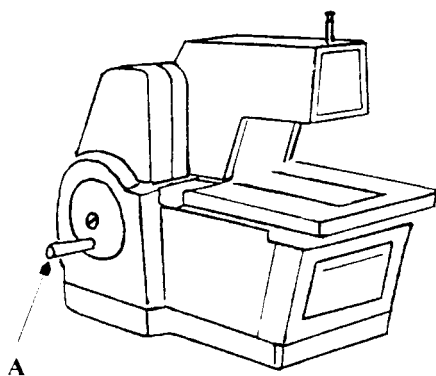

Revised 09/2004

e-mail: service@amfreece.cz; parts@amfreece.cz; website: www.amfreece.com

Phones: +420 582 309 146 (Service), +420 582 309 286 (Spare Parts); Fax: +420 582 360 606

STOP MOTION ADJUSTMENTS

3. Loosen nut **M**, and move rocking lever **N** slightly to the rear. Push link **C** back; lever **D** will latch over roller stud **E**. A clearance of between 0.03 and 0.07 mm (.001 and 0.003") must be maintained between roller **F** and length gauge **G**. To adjust, loosen lock nut **H**, adjust screw **I** up or down (up will decrease the clearance, down will increase the clearance) as necessary. Use a feeler gauge to check. Once the adjustment has been made, re-tighten lock nut **H**.

4. Adjust bumper **J** by loosening screw **K** so that bumper **J** lightly contacts the pin of roller stud **E**. Once this has been done, re-tighten screw **K**.

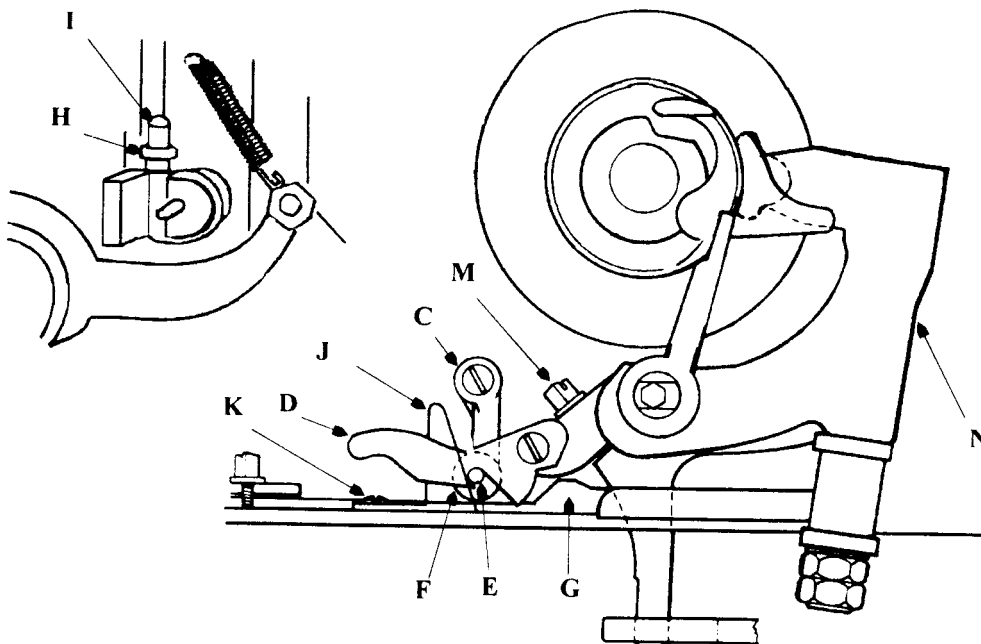

Revised 09/2004

e-mail: service@amfreece.cz; parts@amfreece.cz; website: www.amfreece.com

Phones: +420 582 309 146 (Service), +420 582 309 286 (Spare Parts); Fax: +420 582 360 606

STOP MOTION ADJUSTMENTS

5. The clearance between brake shoe **L** and right hand stop wheel **B** should be 0.25 mm (.010"). To adjust, place the appropriate feeler gauge between brake shoe **L** and right hand stop wheel **B**. Pull rocking lever **N** all the way forward, holding it forward, turn right hand stop wheel **B** counterclockwise until it locks.

6. Ensure all end play between three fork lever **O** and rocking lever **N** has been removed. This is done by sliding the rocking lever shaft all the way to the casting. Move the three fork lever to the right, which will remove all the end play. Re-tighten screw **M**. Remove the feeler gauge.

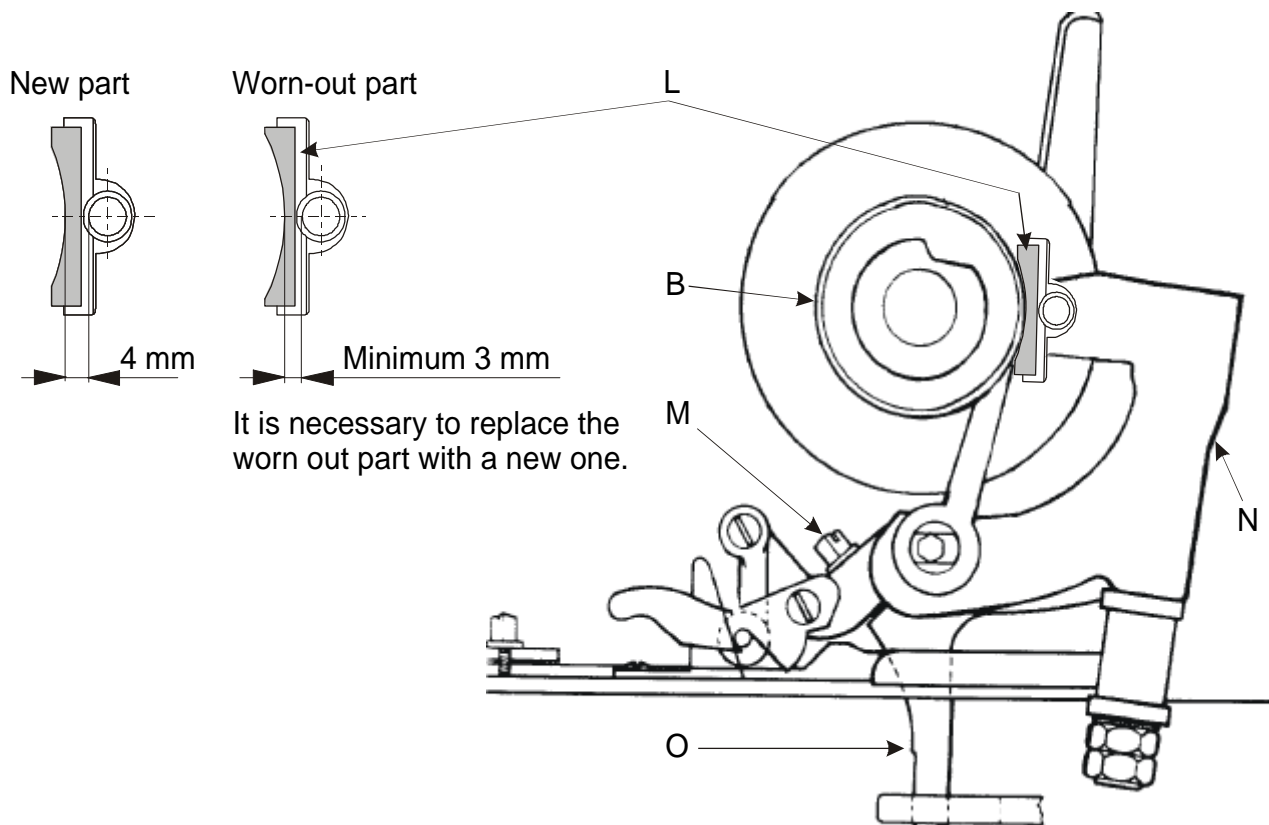

Revised 09/2004

e-mail: service@amfreece.cz; parts@amfreece.cz; website: www.amfreece.com

Phones: +420 582 309 146 (Service), +420 582 309 286 (Spare Parts); Fax: +420 582 360 606

STOP MOTION ADJUSTMENTS

7. While applying slight pressure counterclockwise on the hand grip of right hand stop wheel **B**, turn left hand crank **A** until stop dog **O**, located on the right hand stop wheel, is released. Once the dog is released, stop turning the hand crank immediately.

8. A clearance of up to 0.13 mm (.005") should exist between drive hub **P** and dog **Q**, located on left hand cutting wheel **R**. Set the clearance between dogs by loosening screw **S** and sliding the cutting wheel in or out as necessary. Once the adjustment has been made, re-tighten screw **S**.

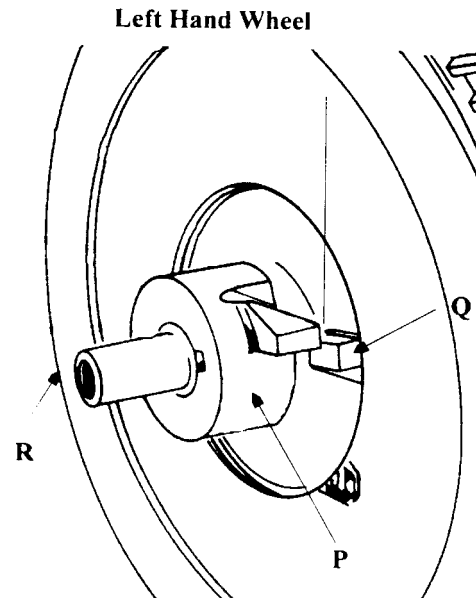
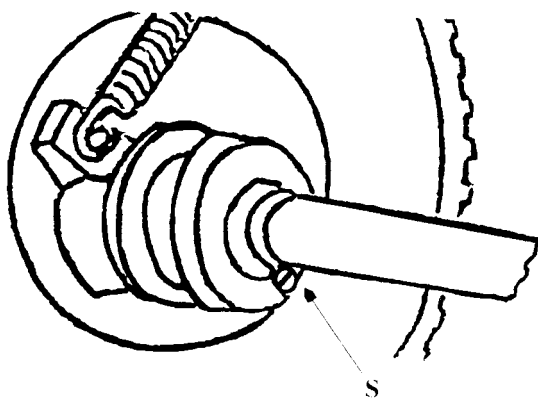
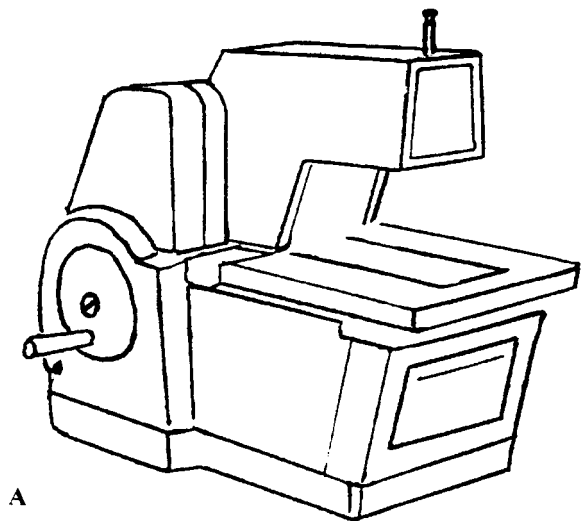
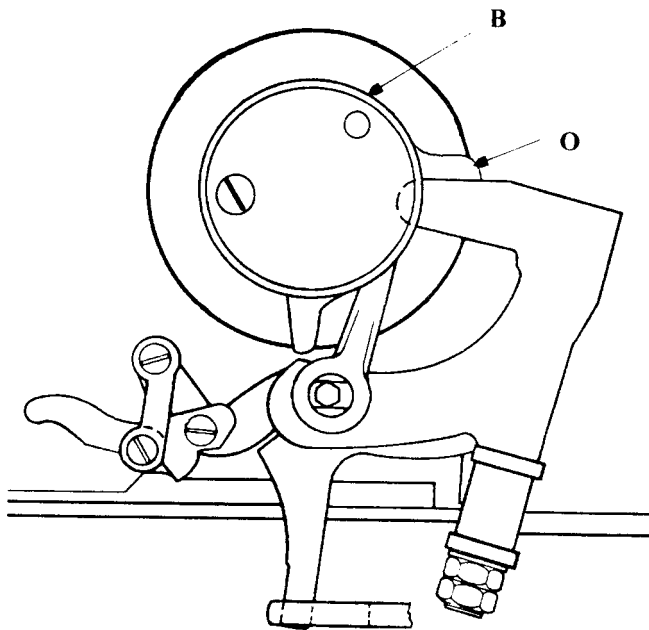

Revised 09/2004

e-mail: service@amfreece.cz; parts@amfreece.cz; website: www.amfreece.com

Phones: +420 582 309 146 (Service), +420 582 309 286 (Spare Parts); Fax: +420 582 360 606

STOP MOTION ADJUSTMENTS

9. Turn right hand stop wheel **B** until stop dog **O** is at 12 o'clock.

10. Turn the left hand crank until roller **F** reaches the high point of length gauge **G**, which is the farthest movement to the rear the rocking lever can make.

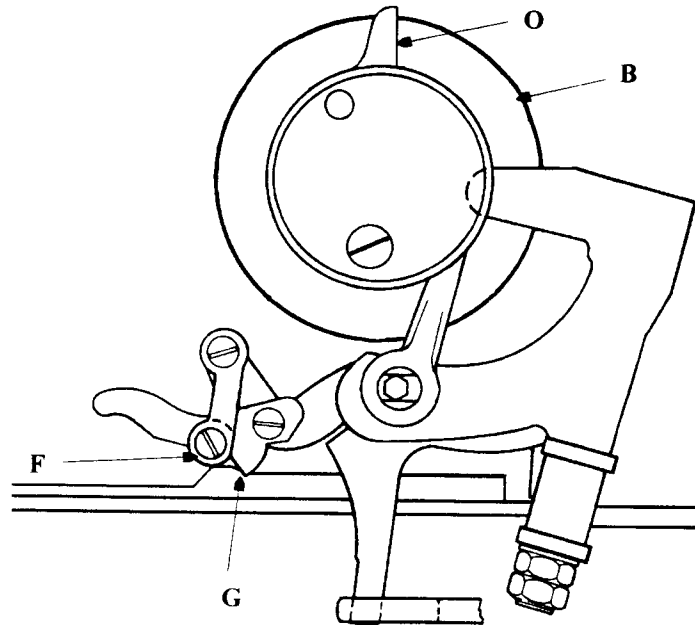

11. Continue turning the left hand crank until lever **D** starts to make an upward movement. At this point, stop turning the left hand crank immediately.

12. The lower portion of trip lever **T** must rest squarely on dog **U**. To adjust, loosen nut **V**. Move trip lever **T** up or down as necessary. Once adjustment has been made, re-tighten nut **V**.

13. Continue turning the left hand crank until roller **F** releases from the length gauge.

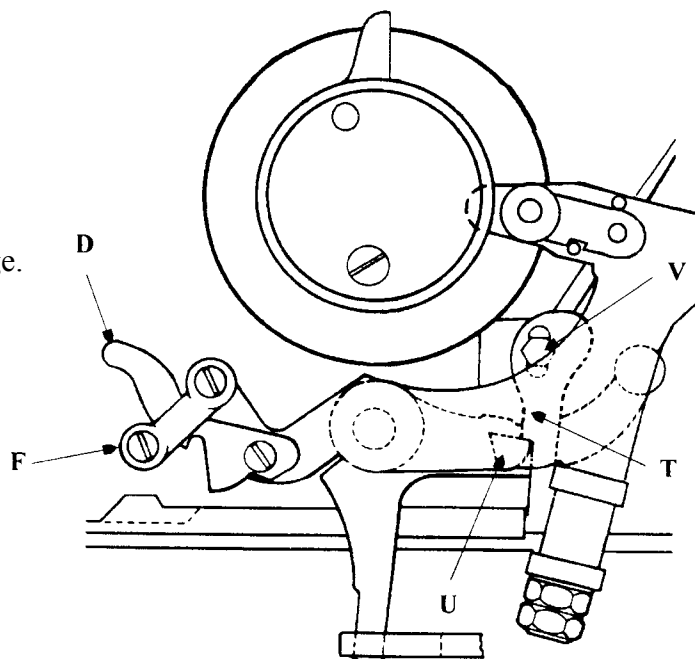

Revised 09/2004

e-mail: service@amfreece.cz; parts@amfreece.cz; website: www.amfreece.com

Phones: +420 582 309 146 (Service), +420 582 309 286 (Spare Parts); Fax: +420 582 360 606

STOP MOTION ADJUSTMENTS

14. Release trip lever **T** by pulling it forward. Turn right hand stop wheel **B** one full rotation until brake shoe **L** rests tightly against the stop wheel. The clearance between drive hub **P** and dog **Q**, located on left hand cutting wheel **R**, should be between 0.25 and 0.38 mm (.010 and .015"). If they do not have the proper clearance, repeat steps 7 through 14.

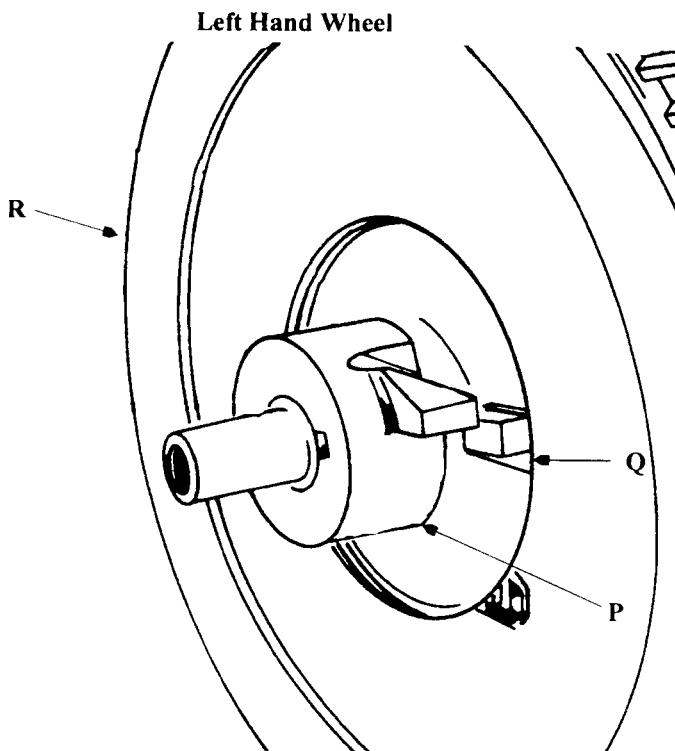
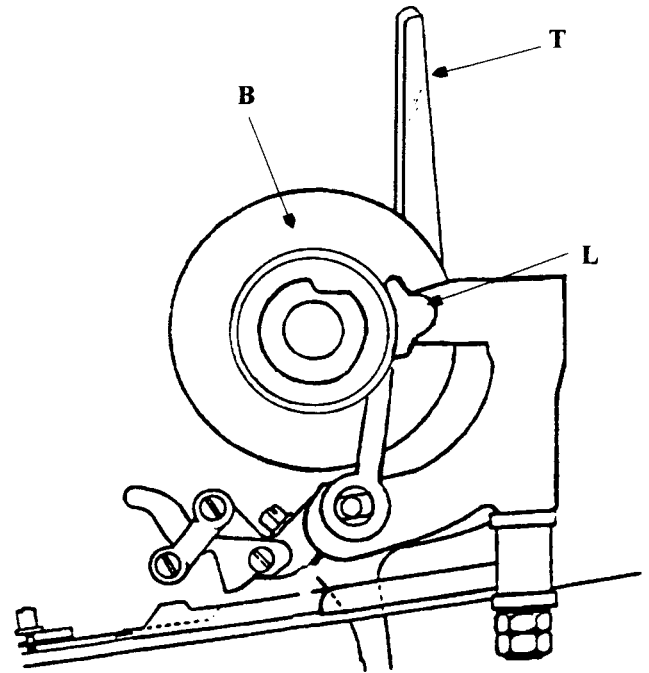

Revised 09/2004

e-mail: service@amfreece.cz; parts@amfreece.cz; website: www.amfreece.com

Phones: +420 582 309 146 (Service), +420 582 309 286 (Spare Parts); Fax: +420 582 360 606

STOP MOTION ADJUSTMENTS

15. Turn right hand stop wheel **B** until the stop dog **O** is locked. Turn the left hand crank until the machine is in home position. A clearance of approximately 0.50 mm (.20") should be maintained between drive hub **P** and dog **Q**, located on left hand cutting wheel **R**. To adjust, loosen nut **W**, move stud **X** forward or backward (forward decreases the gap between dogs; backward increases the gap between dogs) as necessary. Once the adjustment has been made, re-tighten nut **W**.

16. The above adjustment may need to be repeated several times in order to establish the proper home position. To check if the machine is stopping in home position, turn the main power on and cycle the machine. If the machine is not stopping in home position, repeat step 15 (increasing the clearance between dogs will stop the machine sooner, decreasing the clearance will stop the machine later).

17. Once the machine is stopping properly in home position, continue cycling. This is to ensure the machine is starting as well as stopping correctly, and all the adjustments have been done properly. If the machine is not starting and / or stopping correctly - re-check each step to ensure adjustment has been done accurately.

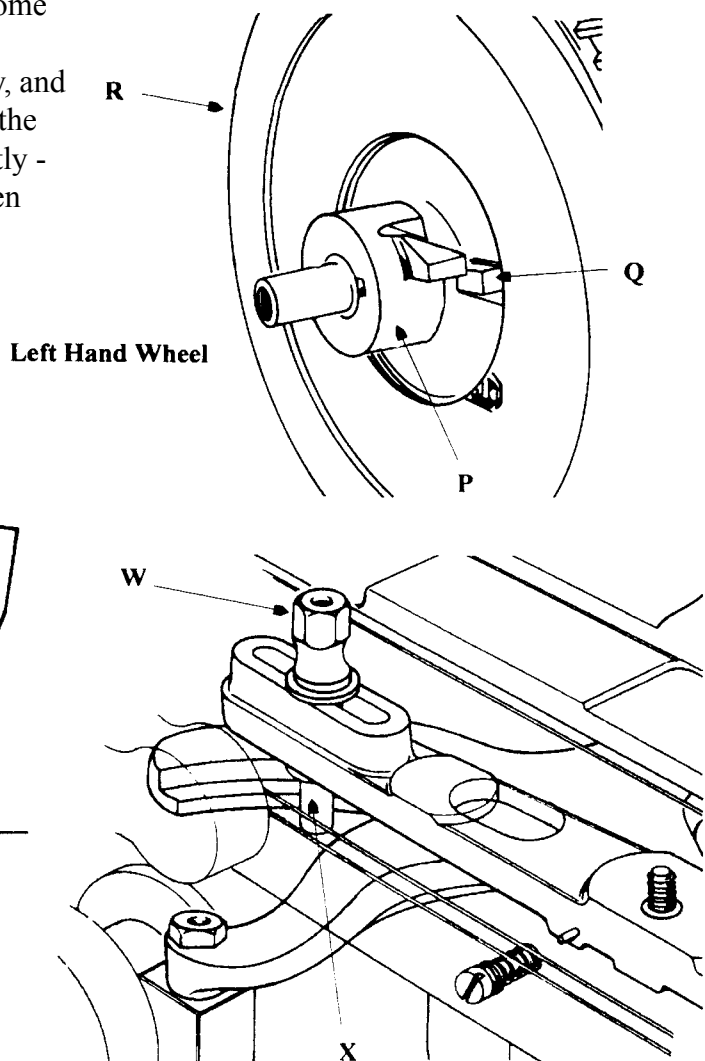

Left Hand Wheel

Revised 09/2004

e-mail: service@amfreece.cz; parts@amfreece.cz; website: www.amfreece.com

Phones: +420 582 309 146 (Service), +420 582 309 286 (Spare Parts); Fax: +420 582 360 606

STOP MOTION ADJUSTMENTS

Ensure you use the correct stop motion procedures for your style machine.

Flyover Lever Stop Motion

When setting the stop motion the CB/CA style machines must be set in CA mode (see page 1-92).

1. Make sure the main power is OFF.
2. Turn the left hand crank until the machine is in home position. Once in the home position, turn right hand stop wheel **B** until it locks in place.
3. Loosen screw **M** and move rocking lever **N** slightly to the rear. Push link **C** back, lever **D** will latch over roller stud **E**. A clearance of between 0.03 and 0.07 mm (.001 and .003”) must be maintained between roller **F** and length gauge **G**. To adjust, loosen lock nut **H**, adjust screw **I** up or down (up will decrease the clearance; down will increase the clearance as necessary. Use a feeler gauge to check. Once the adjustment has been made, re-tighten lock nut **H**.
4. Adjust bumper **J** by loosening screw **K** so that bumper **J** lightly contacts the pin of roller stud **E**. Once this has been done, re-tighten screw **K**.

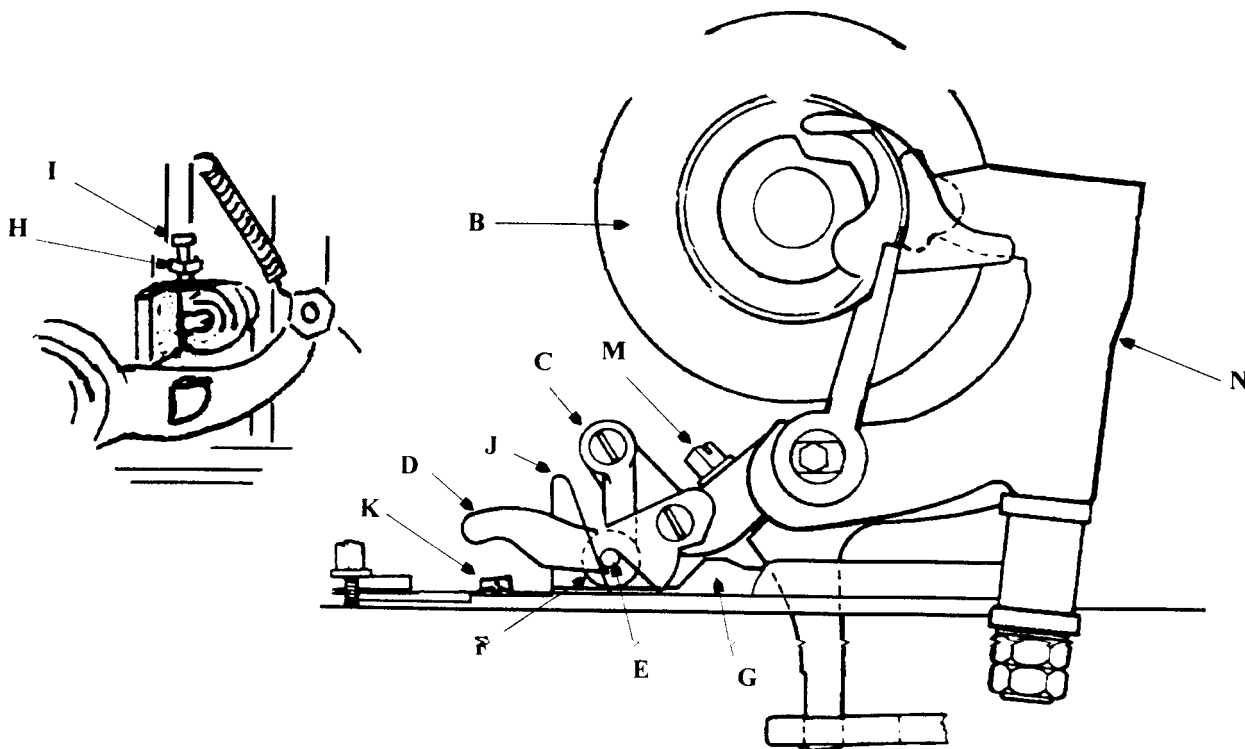

Revised 09/2004

e-mail: service@amfreece.cz; parts@amfreece.cz; website: www.amfreece.com

Phones: +420 582 309 146 (Service), +420 582 309 286 (Spare Parts); Fax: +420 582 360 606

STOP MOTION ADJUSTMENTS

5. A clearance between brake pad **L** and right hand stop wheel **B** should be 0.25 mm (.010"). To adjust, place the appropriate feeler gauge between the brake shoe and the right hand stop wheel. Pull rocking lever all the way forward; holding it forward, turn the right hand stop wheel counterclockwise until it locks.

6. Ensure all end play between three fork lever **O** and rocking lever **N** has been removed. This is done by sliding the rocker lever shaft all the way to the casting. Move the three fork lever to the right, which will remove all the end play. Re-tighten screw **M**. Remove the feeler gauge. Re-check clearance set in step 3, re-set if necessary.

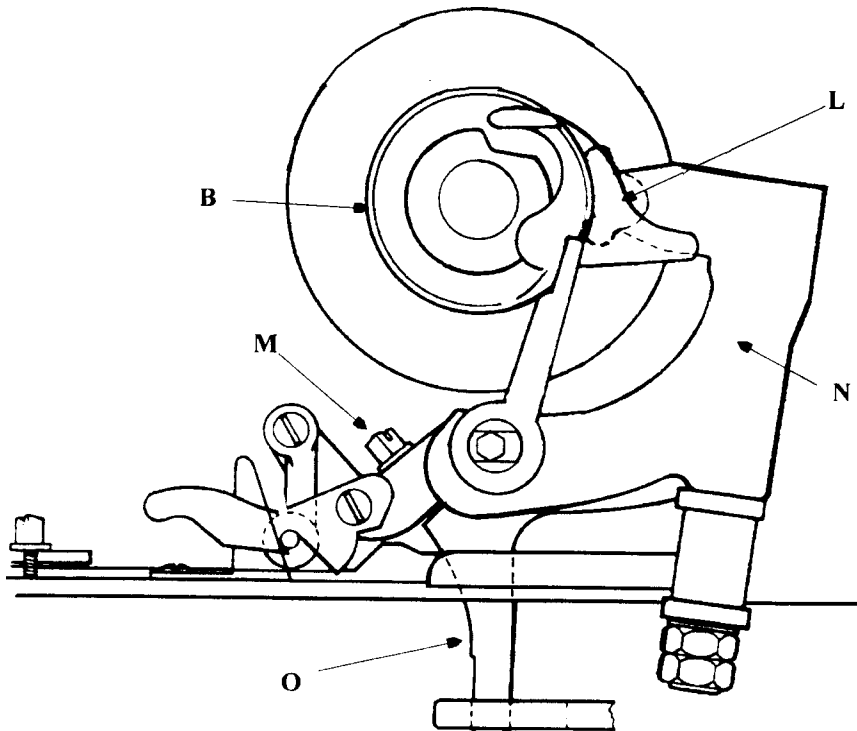

Revised 09/2004

e-mail: service@amfreece.cz; parts@amfreece.cz; website: www.amfreece.com

Phones: +420 582 309 146 (Service), +420 582 309 286 (Spare Parts); Fax: +420 582 360 606

STOP MOTION ADJUSTMENTS

Adjust latch **P** so right hand stitch pulley **Q** is allowed to turn freely. This is done by loosening screw **R** and rotating eccentric bushing **S** so that the wide side is towards the rear of the machine. Latch **P** is against the ledge of right hand stop wheel **B**. Move clutch dog **T** approximately one-half way between the drive cam **U** and the high point of the outside diameter of the right hand stitch pulley **Q**. Once the adjustment has been made, re-tighten screw **R**.

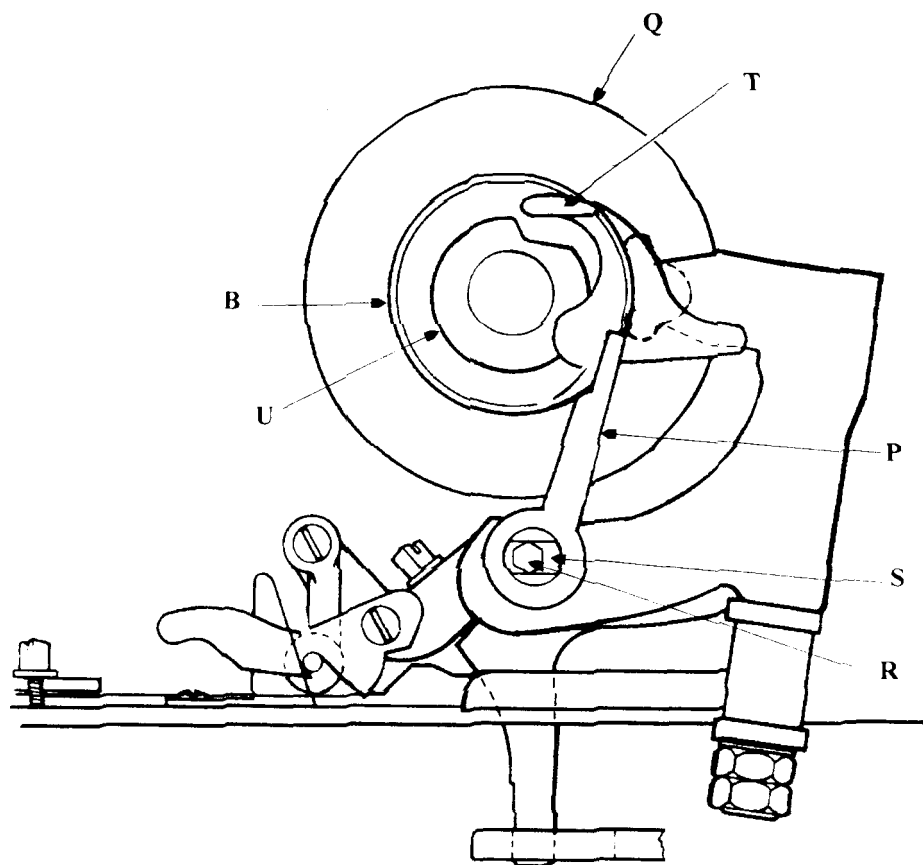

Revised 09/2004

e-mail: service@amfreece.cz; parts@amfreece.cz; website: www.amfreece.com

Phones: +420 582 309 146 (Service), +420 582 309 286 (Spare Parts); Fax: +420 582 360 606

STOP MOTION ADJUSTMENTS

8. Apply slight pressure counterclockwise on hand grip **B**. Turn the left hand crank until stop dog **V** is released. Once the dog has been released, stop turning the hand crank immediately. A clearance of up to 0.13 mm (.005") should exist between drive hub **W** and dog **X**, located on left hand cutting wheel **Y**. To adjust, loosen screw **Z**, and slide the left hand cutting wheel in or out as necessary. Once the adjustment has been made, re-tighten screw **Z**.

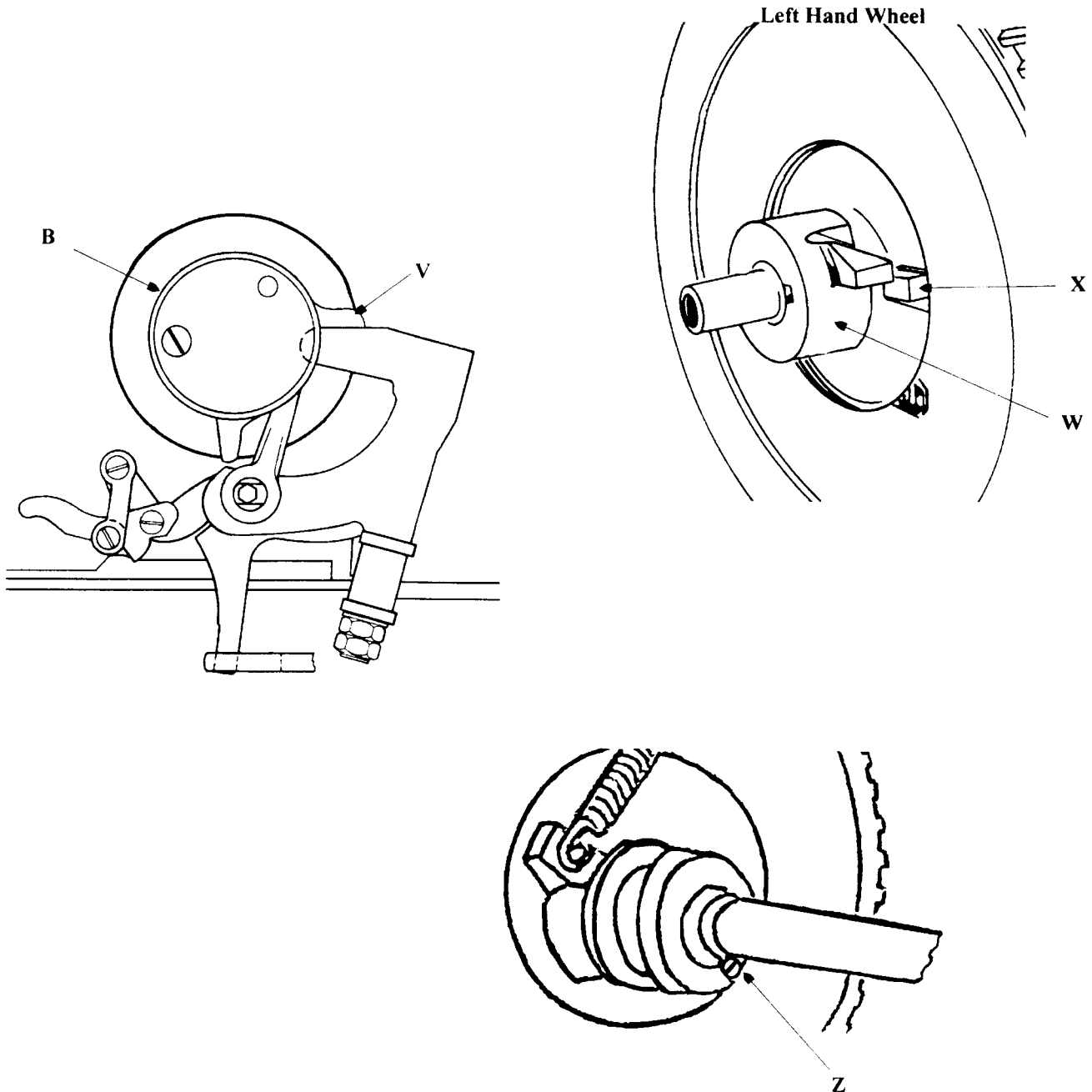

Revised 09/2004

e-mail: service@amfreece.cz; parts@amfreece.cz; website: www.amfreece.com

Phones: +420 582 309 146 (Service), +420 582 309 286 (Spare Parts); Fax: +420 582 360 606

STOP MOTION ADJUSTMENTS

9. Turn the left hand crank until roller **F** reaches the high point of length gauge **G**. Turn right hand stop wheel **B** until the dog is at 6 o'clock. At this point, there should be a clearance of 1.59 mm (.062") between dog **AA** and the end of flyover lever **BB**. To adjust, loosen screw **CC** and move flyover lever **BB** forward or backward as necessary. Once the adjustment has been made, re-tighten screw **CC**.

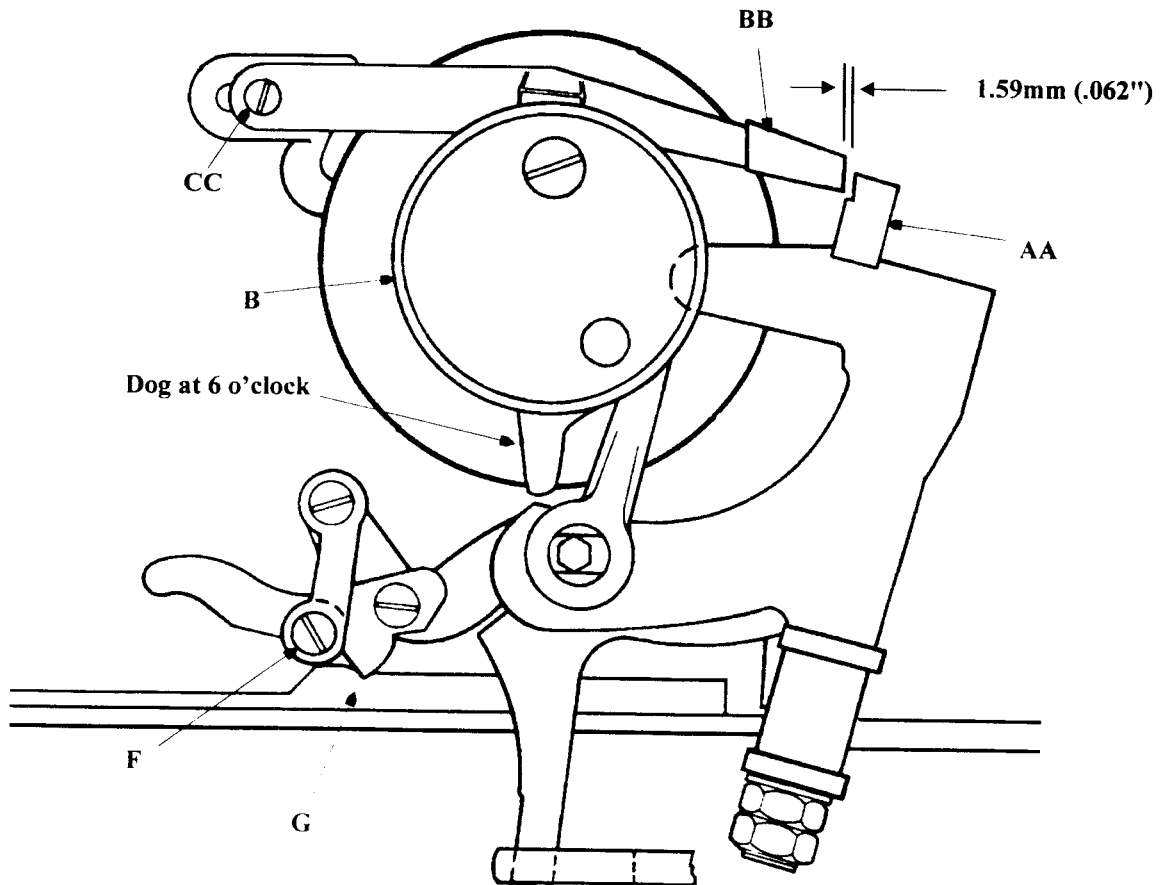

Revised 09/2004

e-mail: service@amfreece.cz; parts@amfreece.cz; website: www.amfreece.com

Phones: +420 582 309 146 (Service), +420 582 309 286 (Spare Parts); Fax: +420 582 360 606

STOP MOTION ADJUSTMENTS

10. A clearance of 0.40 mm (.016") should exist between dog **AA** and flyover lever **BB** after rocking lever **M** has moved forward. To adjust, loosen nut **DD** and move link **EE** down until it is sitting squarely on the top of dog **II**. Re-tighten nut **DD** just enough to hold link **EE** lightly in place. Lift **D** and allow roller **F** to release from length gauge **G**. At this time, rocking lever **M** will move slightly forward. Using a hammer, tap rocking lever **M** forward until the proper clearance has been obtained. Once the proper clearance has been obtained, finish re-tightening nut **DD**.

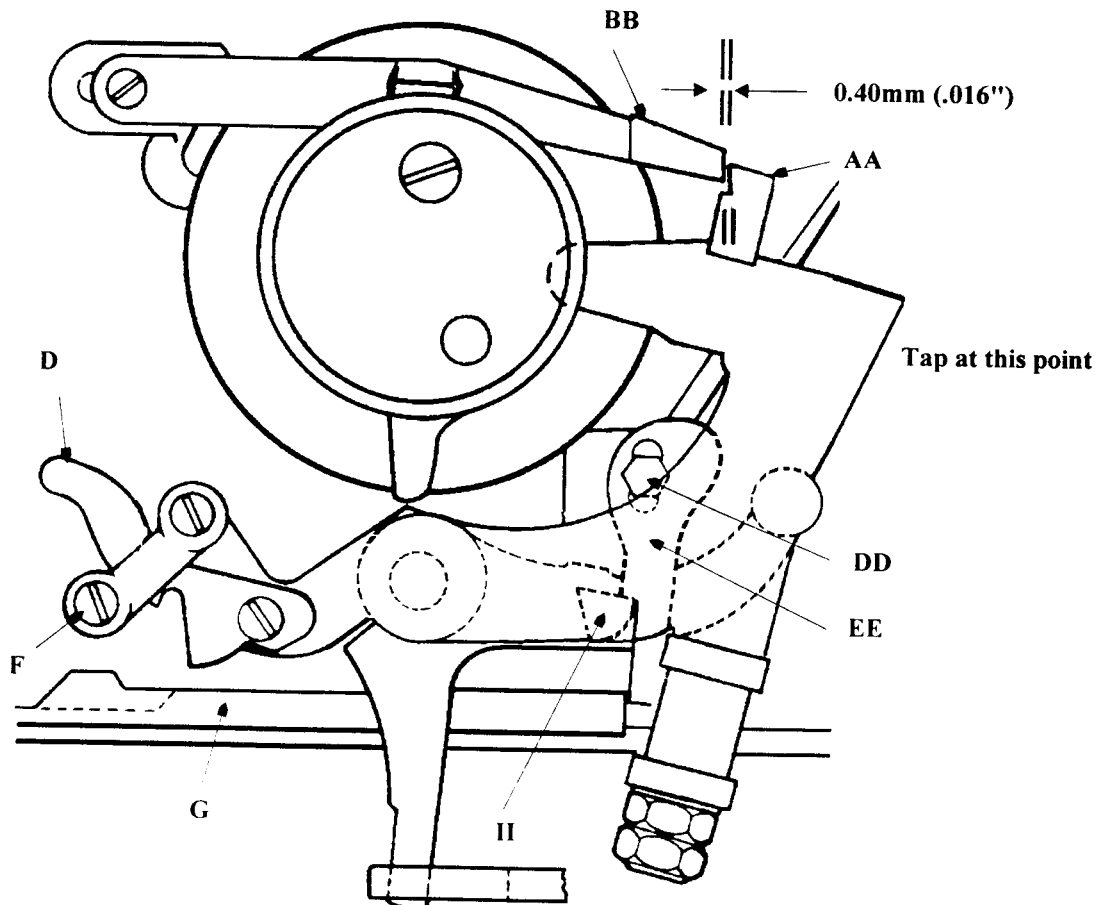

Revised 09/2004

e-mail: service@amfreece.cz; parts@amfreece.cz; website: www.amfreece.com

Phones: +420 582 309 146 (Service), +420 582 309 286 (Spare Parts); Fax: +420 582 360 606

STOP MOTION ADJUSTMENTS

11. Turn right hand stop wheel **B** until the dog is at 12 o'clock. Pull the top portion of trip lever **EE** forward until it releases. At this point, dog **AA** should just touch the underside of flyover lever **BB** without lifting it. To adjust, with a hammer lightly tap top bracket **FF** to the machine head up or down (up decreases the gap; down increases the gap) as necessary.

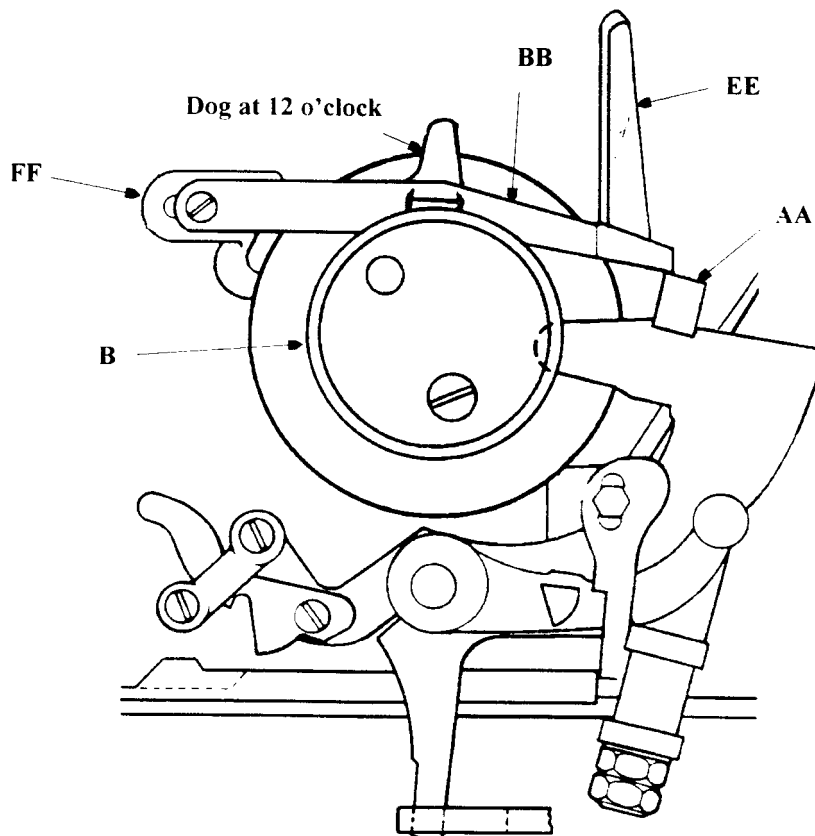

Revised 09/2004

e-mail: service@amfreece.cz; parts@amfreece.cz; website: www.amfreece.com

Phones: +420 582 309 146 (Service), +420 582 309 286 (Spare Parts); Fax: +420 582 360 606

STOP MOTION ADJUSTMENTS

12. Turn the left hand crank until the machine has moved through the eye position. Left hand dogs **X** and drive hub **W** should have an approximate clearance of up to 0.40 (.016"). If the proper clearance does not exist between left hand dogs and drive hub, repeat steps 6 through 8.

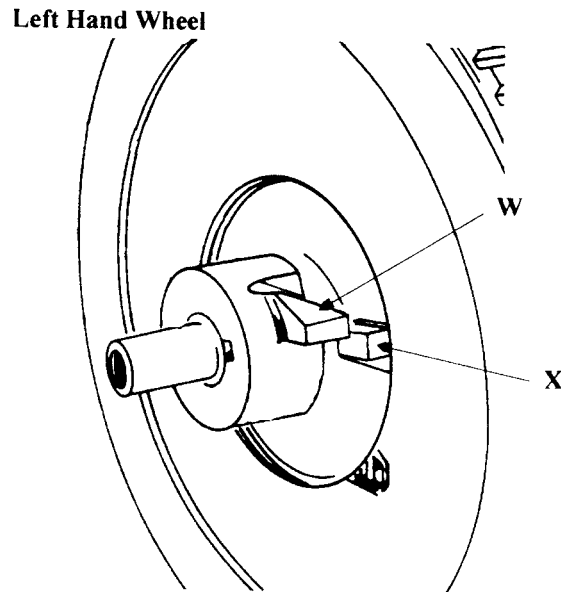

STOP MOTION ADJUSTMENTS

13. Turn the right hand stop wheel until it locks in place. Turn the left hand crank until the machine is in home position. A clearance of approximately 0.50 mm (.020") is required between drive hub **W** and left hand dog **X**. To adjust, loosen nut **GG**, move stud **HH** forward or backward (forward decreases the gap; backward increases the gap) as necessary. Once the adjustment has been made, re-tighten nut **GG**.
14. Turn the main power on and cycle the machine to ensure that it is stopping in home position. If it is not stopping in home position, repeat step 13 to increase or decrease the clearance (increasing the clearance will stop the machine sooner, decreasing the clearance will stop the machine later) as necessary.
15. Once the machine is stopping properly in the home position, continue cycling the machine. This is done to ensure it is starting as well as stopping correctly and that all adjustment have been done properly. If the machine is not starting and/or stopping correctly, re-check each step to ensure correct adjustments have been made.

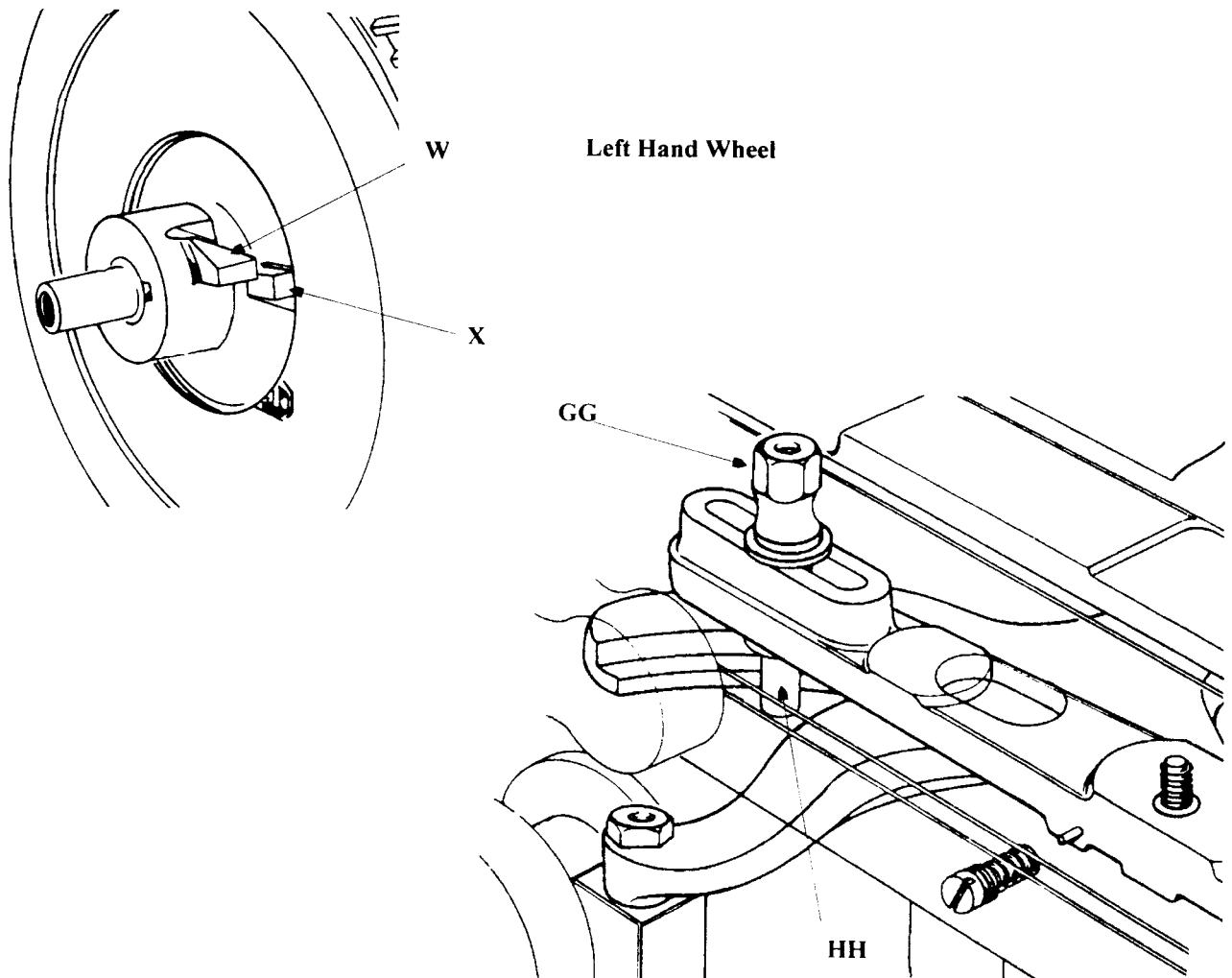

Revised 09/2004

e-mail: service@amfreece.cz; parts@amfreece.cz; website: www.amfreece.com

Phones: +420 582 309 146 (Service), +420 582 309 286 (Spare Parts); Fax: +420 582 360 606

STOP MOTION ADJUSTMENTS

Ensure you use the correct stop motion procedures for your style machine.

Round Eye Stop Motion

Home position is after the upper thread trimming action has occurred. The bedplate will travel a short distance to the rear of the machine and stop. The race will be facing the left side of the machine.

1. Turn the left hand crank until the machine reaches home position. Turn the right hand stop wheel until it locks.
2. Turn the left hand crank until stitch rod **A** reaches its highest point. Turn the right hand stop wheel until stop dog **B** is at 12 o'clock. Visually check to make sure a clearance between roller **C** and the right hand stop wheel is between 0.39 and 0.77 mm (.015 and .030"). To adjust, loosen clamp bolt **D** and move rocking lever **E** forward or backward until clearance has been obtained. Once the clearance has been obtained, re-tighten clamp bolt **D**.

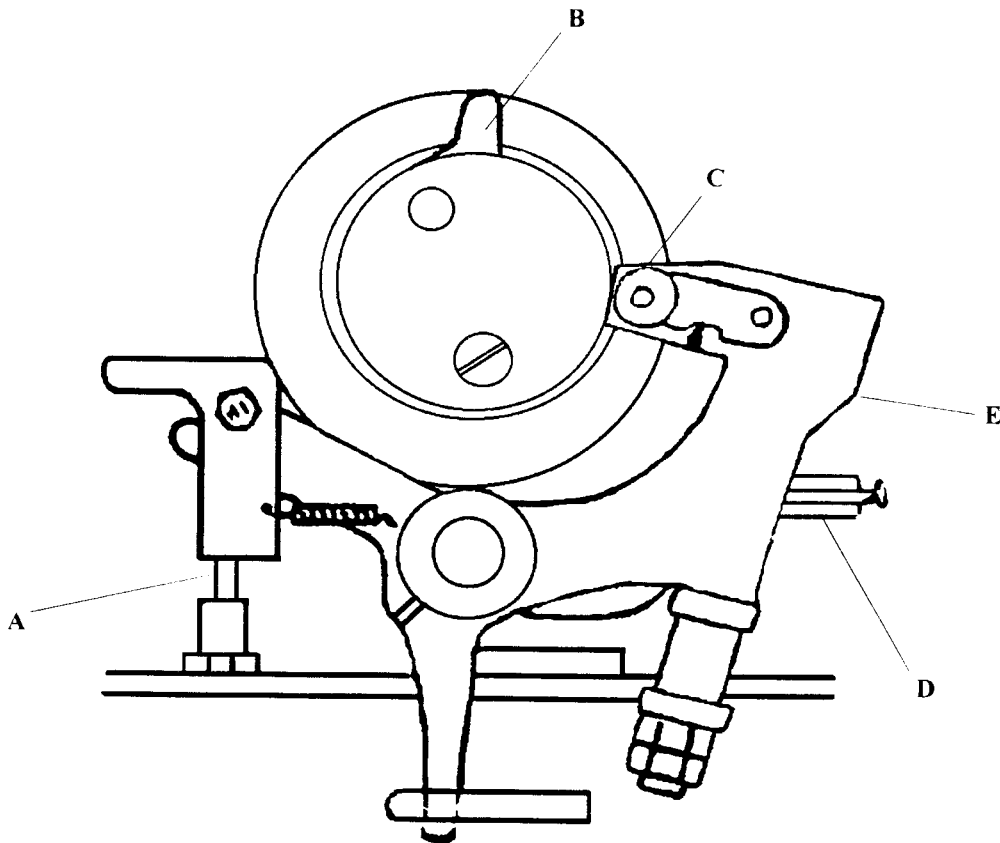

Revised 09/2004

e-mail: service@amfreece.cz; parts@amfreece.cz; website: www.amfreece.com

Phones: +420 582 309 146 (Service), +420 582 309 286 (Spare Parts); Fax: +420 582 360 606

STOP MOTION ADJUSTMENTS

3. Turn the left hand crank until the machine reaches the home position. Turn the right hand stop wheel until it locks. Continue turning the left hand crank until stop dog **B** is released from the right hand stop wheel. Once dog is released, stop turning crank immediately. A clearance of 0.13 mm (.005") must be maintained between the dog on the left hand wheel and drive hub **F**. To adjust, loosen screw **G** and move the left hand wheel in or out as necessary. Check with a feeler gauge for the proper clearance. Once the proper clearance has been obtained, re-tighten screw **G**.

4. Turn the left hand crank until machine is in the home position. Turn the right hand stop wheel until it locks. A clearance of approximately 0.50 mm (.020") should be maintained between drive hub **F** and dog **H**. To adjust, loosen nut **J**, move stud **K** forward or backward (forward decreases the gap; backward increases the gap) as necessary. Once the adjustment has been made, re-tighten nut **J**.

NOTE: It is not uncommon when a 3-fork lever has been replaced, the clearance between drive hub **G** and dog **H** may not be able to be obtained without bending the lower leg of the 3-fork lever.

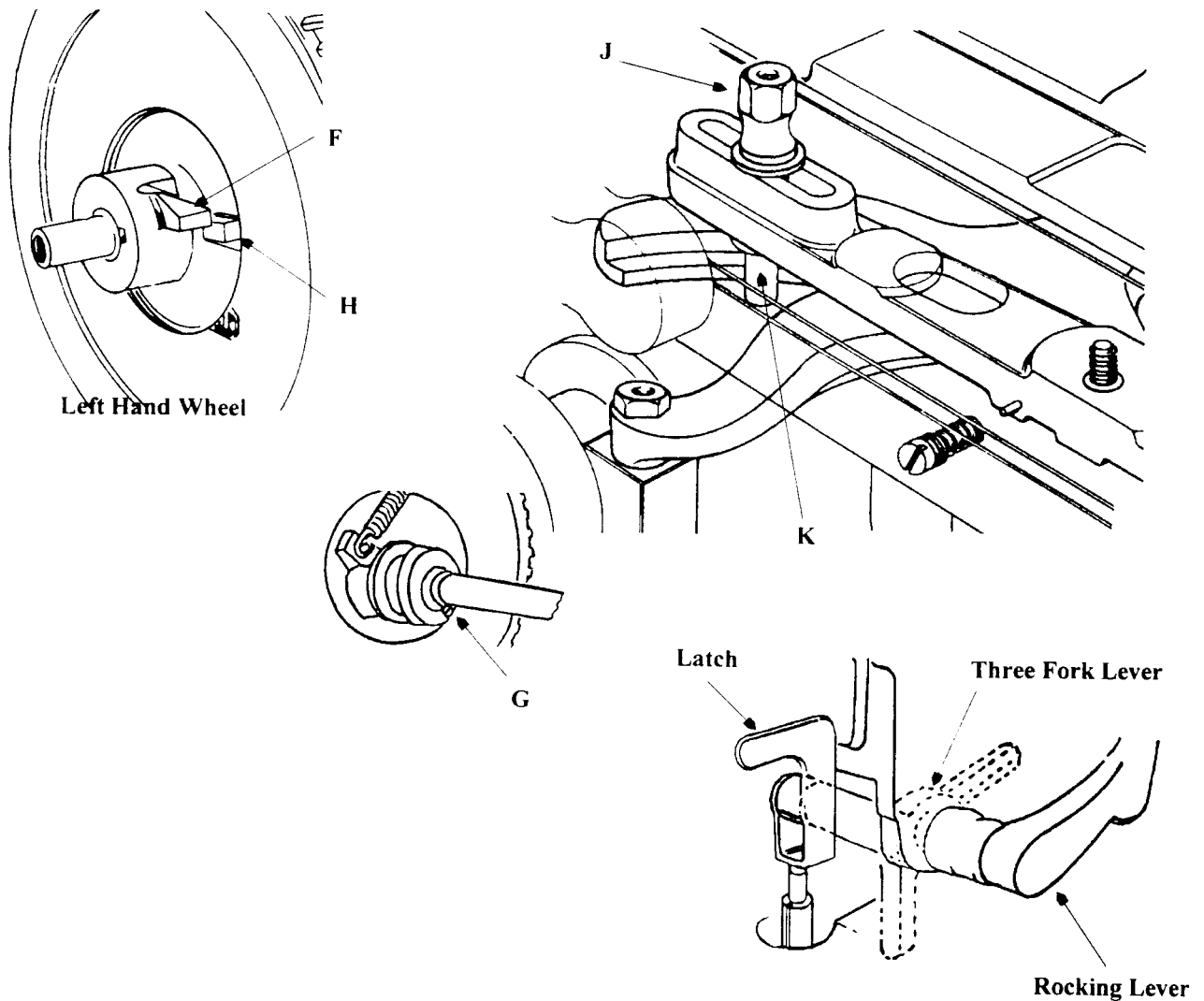

Revised 09/2004

e-mail: service@amfreece.cz; parts@amfreece.cz; website: www.amfreece.com

Phones: +420 582 309 146 (Service), +420 582 309 286 (Spare Parts); Fax: +420 582 360 606

STOP MOTION ADJUSTMENTS

5. The adjustment described in step 4 may need to be repeated several times in order to establish the proper home position. To check, turn main power on and cycle the machine to ensure that it is stopping in the home position. If it is not stopping in the home position, repeat step 4 (increasing the clearance between dogs will stop the machine sooner; decreasing the clearance will stop the machine later).
6. Once the machine stopping properly in the home position, continue cycling. This is to ensure it is starting as well as stopping correctly, and that all adjustments have been done properly. If the machine is not starting and / or stopping correctly, re-check each step to ensure adjustments have been done accurately.
7. If an emergency stop is required, lifting the latch will stop the stitching and allow the machine to return to the home position. Before starting the next buttonhole, ensure the latch is positioned squarely over the stitch rod. If it is not squarely over the stitch rod, push rocking lever to the rear until the latch positions itself over the stitch rod.

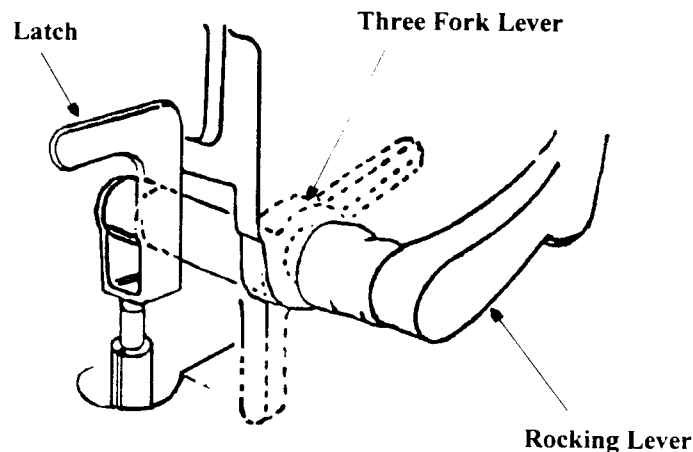

Revised 09/2004

e-mail: service@amfreece.cz; parts@amfreece.cz; website: www.amfreece.com

Phones: +420 582 309 146 (Service), +420 582 309 286 (Spare Parts); Fax: +420 582 360 606

SLIP CLUTCH ADJUSTMENTS

The slip clutches are factory set to absorb starting load by slipping 45 to 100 degrees upon pick-up of the first stitch. The clutch may slip within this range without any problem, but needs to be periodically checked with gauge 03.0403.0.000. To check the amount of slippage, perform the following steps:

1. Put a mark on spur gear **A** in relation to the position of the lockwasher tab **B**.
2. Turn the power on. Cycle the machine through one stitching cycle. Turn the power off.
3. Check the amount of slippage by lining up the '0' marking on gauge **C** to lockwasher tab **B**, and bend the gauge around spur gear **A**. Read the amount of slippage on gauge corresponding to the mark put on the drive hub.
4. If the mark falls short of the 45 degree position, open lockwasher tab **B** and move lock nut **D** approximately 15 degrees counterclockwise and bend lockwasher tab **B** onto slot of lock nut **D**. Repeat step 3.
5. If the mark is beyond the 100 degree position, open lockwasher tab **B** and move lock nut **D** approximately 15 degrees clockwise and bend lockwasher tab **A** onto slot of lock nut **D**. Repeat step 3.
6. Although the machine will function with a tight clutch (under 45 degree slippage), it will cause excessive wear on all stitch drive parts. Eventually, it will break the clutch dog.

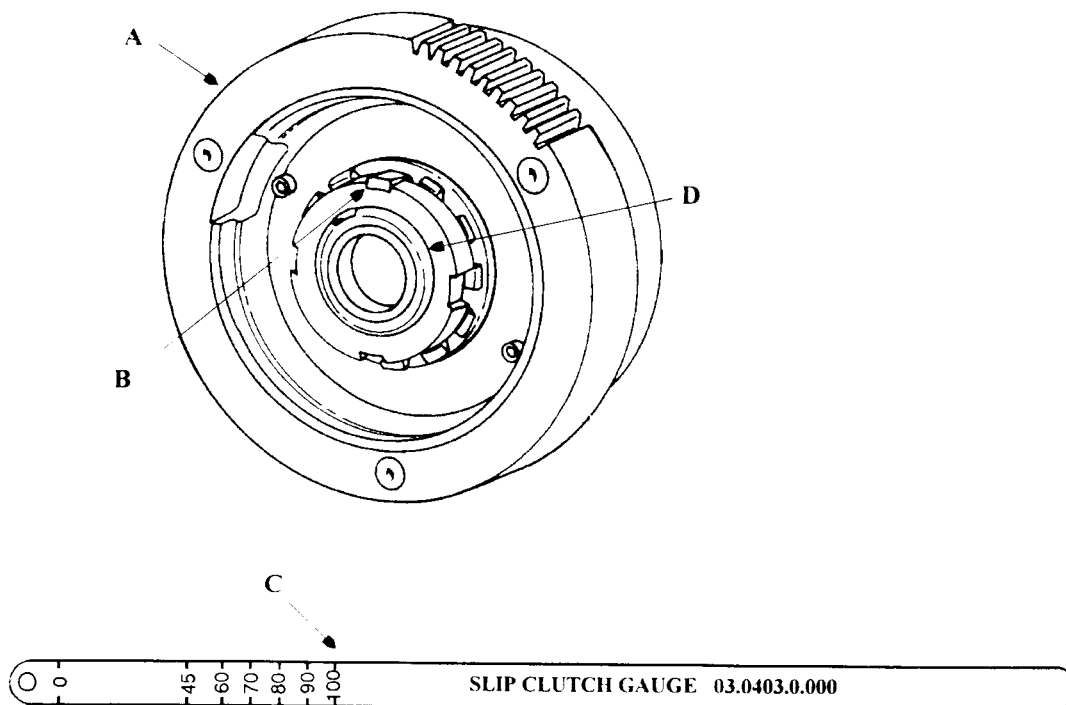

Revised 09/2004

e-mail: service@amfreece.cz; parts@amfreece.cz; website: www.amfreece.com

Phones: +420 582 309 146 (Service), +420 582 309 286 (Spare Parts); Fax: +420 582 360 606

RACE ADJUSTMENTS

Race to Side of Bedplate

1. Remove the throat plate, loopers and spreaders.
2. Set the machine in the eye mode, using eye / no-eye shifter **A** located in the rear of the bedplate.
3. Turn the left hand crank, stopping once to ensure that holes **B** (located on the head and bedplate) are in alignment.
4. Locate scribe line **C** on the rear of the bedplate. Using a straight edge, mark a matching scribe line onto the head at position **D**. Slowly continue to turn the left hand crank until the machine has started into the eye portion of the cycle. Stop turning the left hand crank once scribe lines **C** and **D** are in alignment.

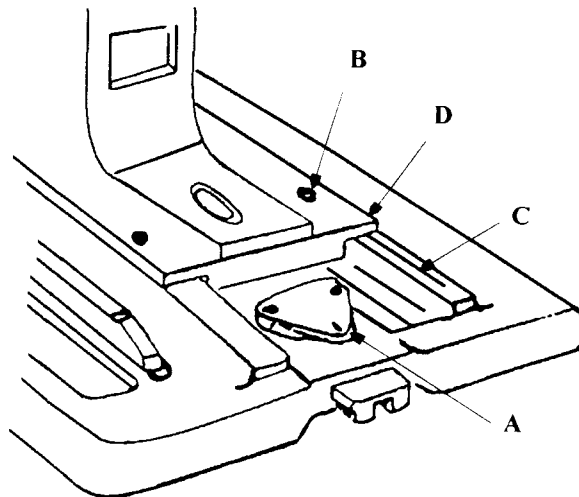

RACE ADJUSTMENTS

5. Race should have traveled 90 degrees to the bedplate, as shown below. If the race did not travel 90 degrees, perform steps 6 and 7.
6. Place a straight edge across the front of the race and check distance on both sides of the race to the side of the bedplate.
7. Lift the machine. Loosen allen cap screw **E** and move it either up or down (up moves the race to the left, down moves the race to the right) as necessary. Once the adjustment has been made, re-tighten screw **E**.

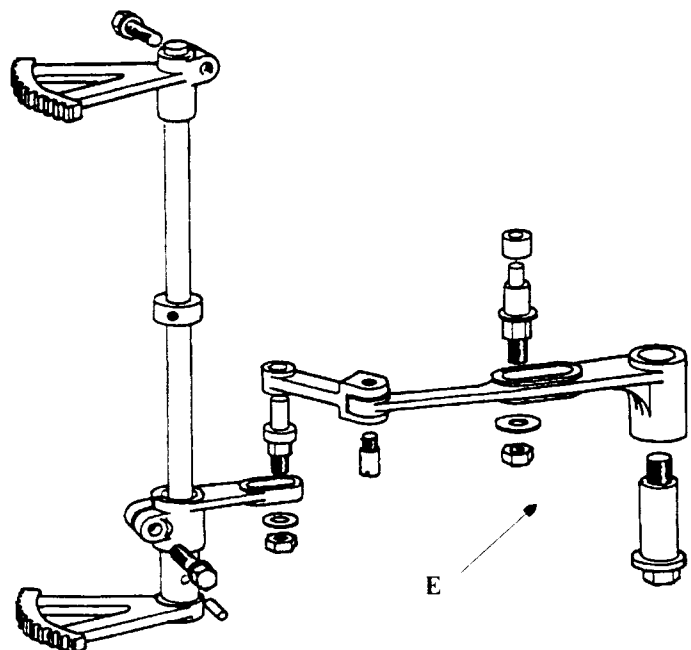
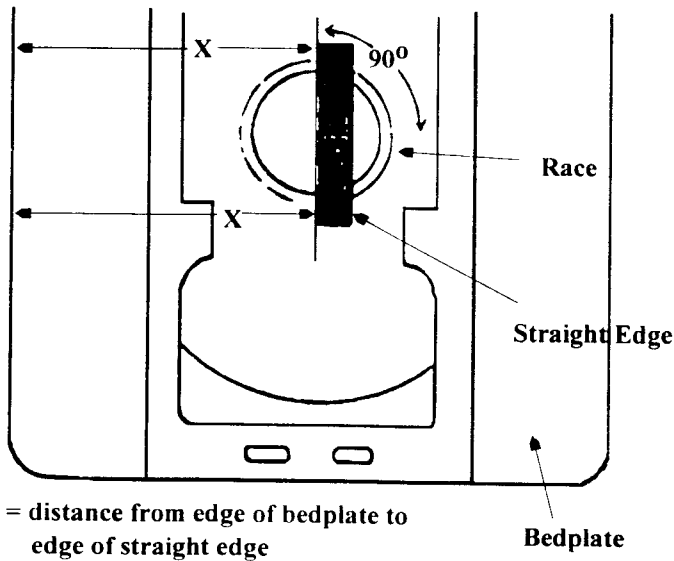

Revised 09/2004

e-mail: service@amfreece.cz; parts@amfreece.cz; website: www.amfreece.com

Phones: +420 582 309 146 (Service), +420 582 309 286 (Spare Parts); Fax: +420 582 360 606

RACE ADJUSTMENTS

Race to Needle Bar Gears

With race at 90 degrees, upper vibrator block should be visually square to race. To adjust, loosen nut **F**, and rotate upper sector gear **G** to square it off. Once this has been done, re-tighten nuts **F**.

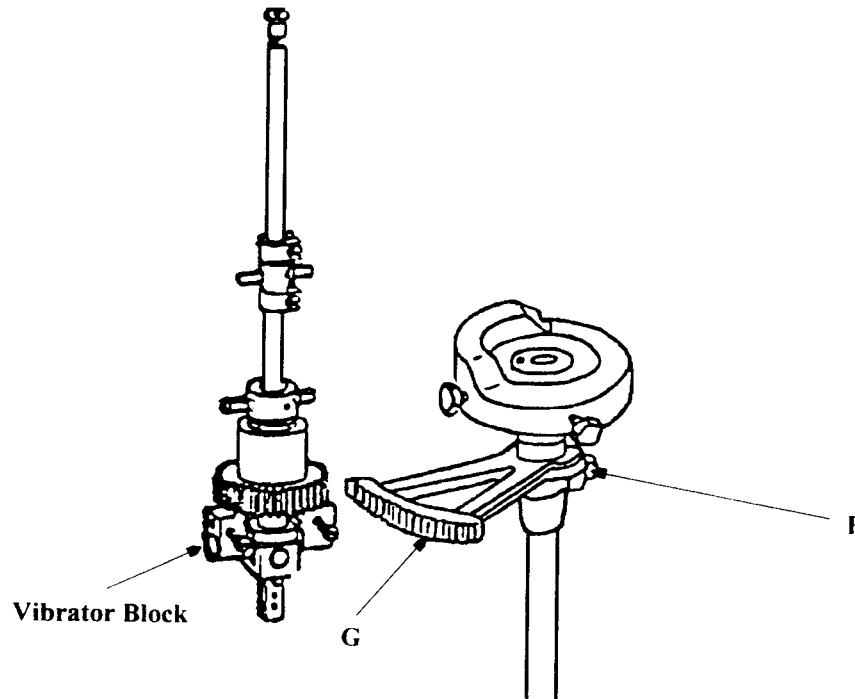

Race 180 degree travel

1. Lower the machine. Turn the left hand crank until the machine is in the home position. Once at home, continue turning the left hand crank, stopping 1/2 way along the first row of stitches.

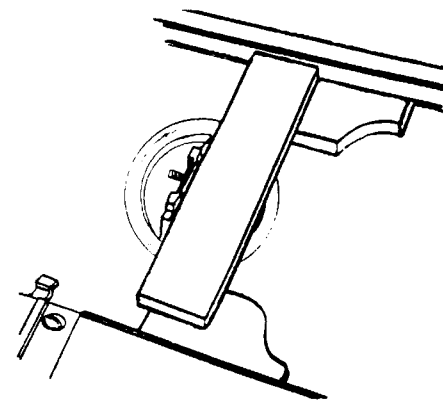
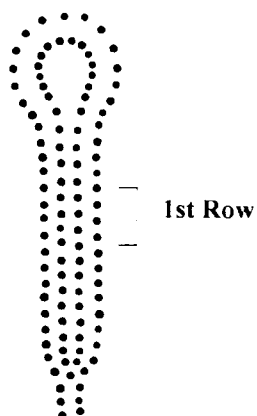

2. Place a straight edge across the front of the race. Look at the race in relation to the straight edge - note the distance, if any, between the two.

Revised 09/2004

e-mail: service@amfreece.cz; parts@amfreece.cz; website: www.amfreece.com

Phones: +420 582 309 146 (Service), +420 582 309 286 (Spare Parts); Fax: +420 582 360 606

RACE ADJUSTMENTS

3. Continue turning the left hand crank through the eye of the buttonhole, stopping at the second row of stitches.

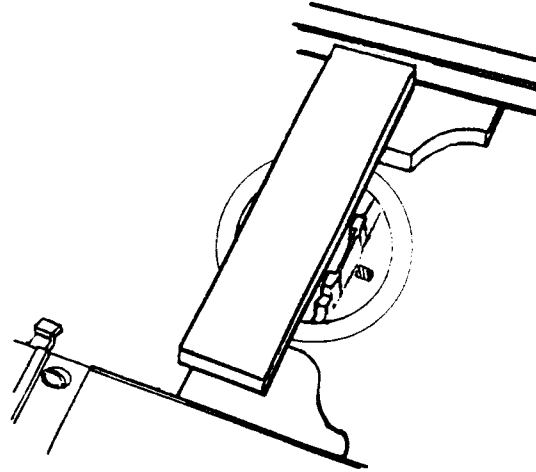
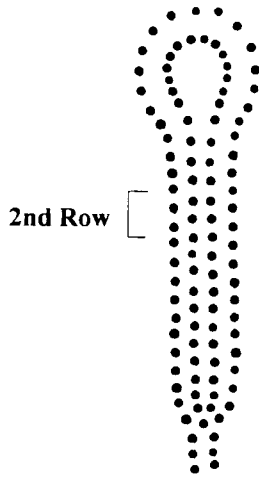

4. Place a straight edge across the front of the race. Look at the race in relation to the straight edge - note the distance, if any, between the two.

5. If there is no distance between race and straight edge on either position, the travel is correct. If there is a distance between the race and the straight edge, perform steps 6 through 9.

Revised 09/2004

e-mail: service@amfreece.cz; parts@amfreece.cz; website: www.amfreece.com

Phones: +420 582 309 146 (Service), +420 582 309 286 (Spare Parts); Fax: +420 582 360 606

RACE ADJUSTMENTS

6. Lift the machine. Loosen nut **H**, and move up or down (up moves the race clockwise; down moves the race counterclockwise) equaling 1/2 distance between the straight edge and the race. Once the adjustment has been made, re-tighten nut **H**.

7. Repeat steps 1 and 2.

8. Lift the machine. Loosen nut **I**, and rotate the race either right or left as necessary in order to square race to straight edge. Once the adjustment has been made, re-tighten nut **I**.

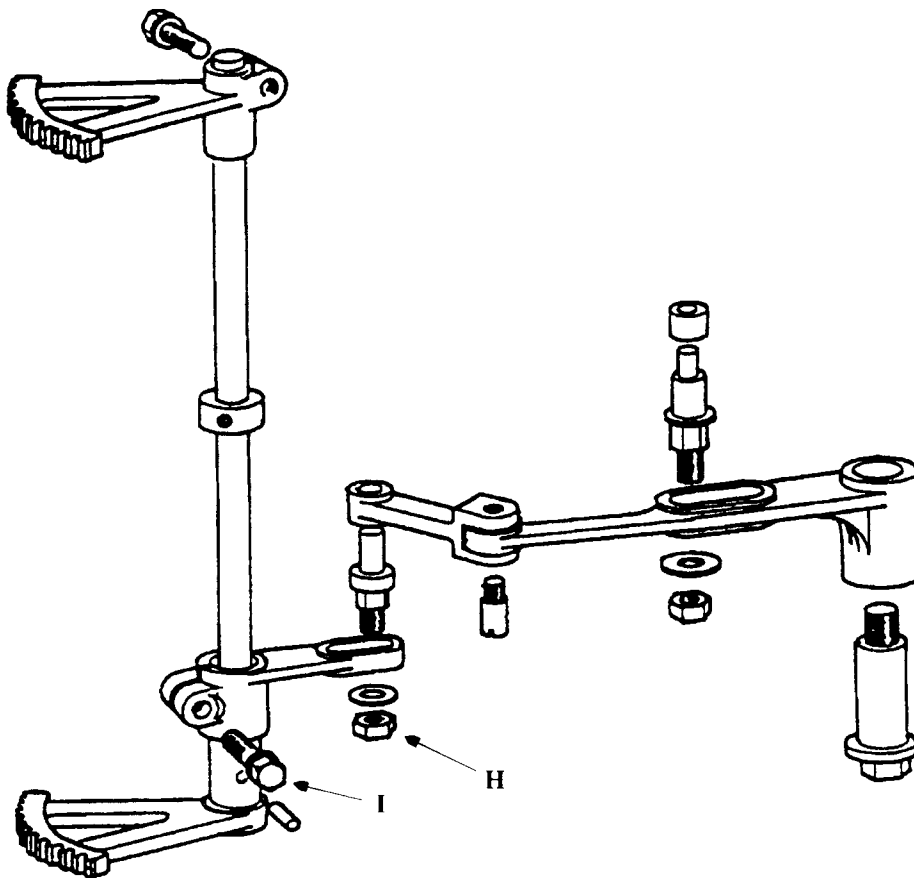

9. Re-check 90 and 180 degree movement of the race, reset if required.

NOTE: It is not uncommon to have to repeat these steps several times.

ADJUSTABLE FLYBAR PINS SETTINGS - NO EYE

NOTE: The flybar brackets have been adjusted and pinned in the factory. If the pins are working freely, no adjustment is necessary. If they are not working freely, perform the following steps:

1. Set the machine to the no-eye position using the eye/no-eye shifter located in the rear of the bedplate.
2. Turn the left hand crank until the race is 90 degrees to the bedplate.
3. Lift the machine. Remove springs **B**, loosen clamp **C** by loosening screw **D**. This will allow the clamp to fall back.
4. Slide left flybar actuator **F**, to the left, repeat for the right flybar actuator **F**. This will free flybar pins **G** so they can easily slide in and out of flybar bracket **H**. **PINS MUST SLIDE FREELY WITHIN BRACKET.**
5. Ensure that both pins will fit into cam plate slots **I** freely. If they don't, adjust by loosening hex bolts, and attaching flybar bracket **H** to the cam case. Remove the tapered pin located through the cam case and flybar bracket **H**.

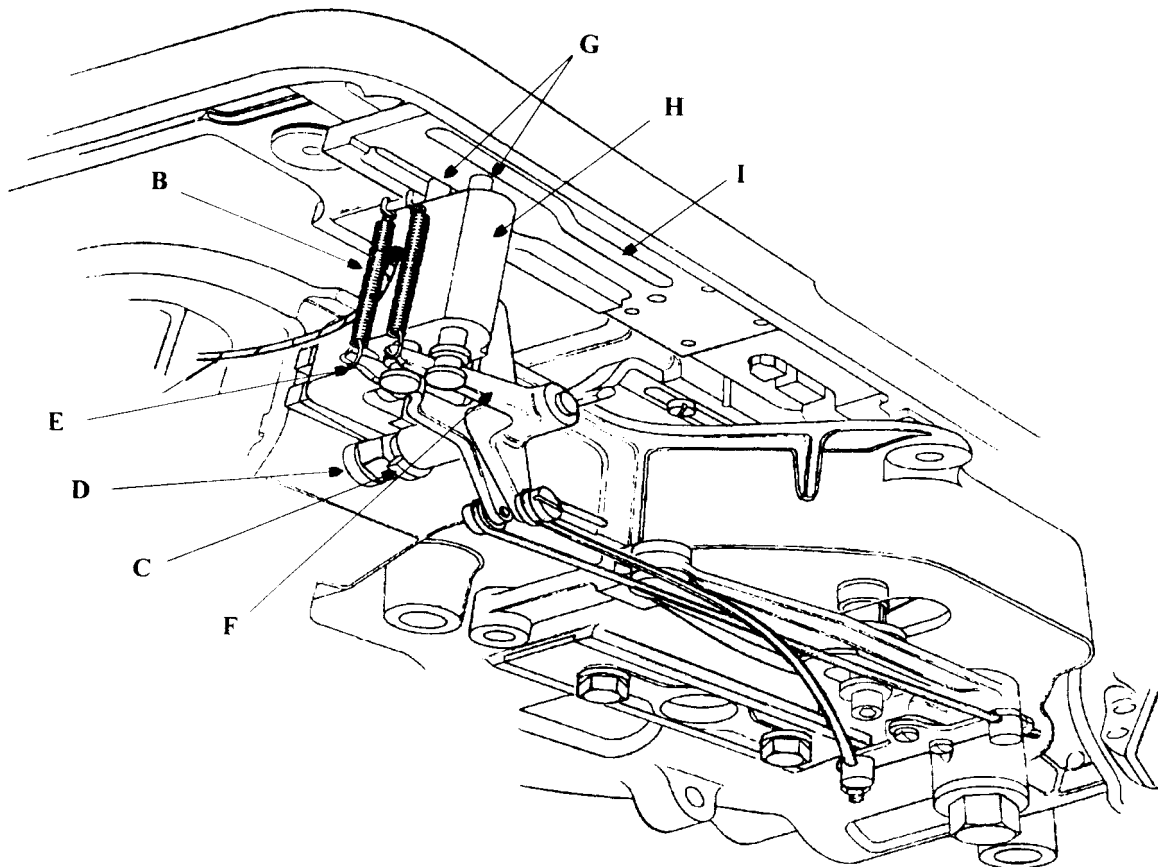

Revised 09/2004

e-mail: service@amfreece.cz; parts@amfreece.cz; website: www.amfreece.com

Phones: +420 582 309 146 (Service), +420 582 309 286 (Spare Parts); Fax: +420 582 360 606

ADJUSTABLE FLYBAR PINS SETTINGS - NO EYE

6. Move spacer wedges **J** close together or further apart (closer moves flybar bracket to the right; further moves the bracket to the left) so that flybar pins **G** will line up to fit into cam plate slots **I**.

7. Re-tighten the hex bolts. Check the fit of flybar pins **G** into cam plate slots **I**. If pins do not fit or are not working freely, repeat steps 5 and 6. If they do fit and are working freely, reattach flybar actuators **E** and **F**, as well as clamp **C**. Re-tighten screw **D**, and re-attach springs **B**.

8. Flybar pin **G** should enter cam plate slots **I** at a maximum depth of 1/8 inch. To adjust, tighten nuts **J** and move in or out (in will decrease the depth the pin travels into cam plate slot, out will increase the depth) as necessary.

9. Turn the left hand crank until the roll on lateral lever is captured in peak of main cam. At this point, flybar pin should have withdrawn from slot of cam plate. To adjust, loosen screw **K** and move bracket **L** up or down (moving bracket up will cause the pin to exit sooner, moving bracket down will cause the pin to exit later) as necessary. Once this adjustment has been made, re-tighten screw **K**.

10. Cycle the machine to ensure the left hand flybar pin exits properly. If it does not exit properly, repeat steps 9.

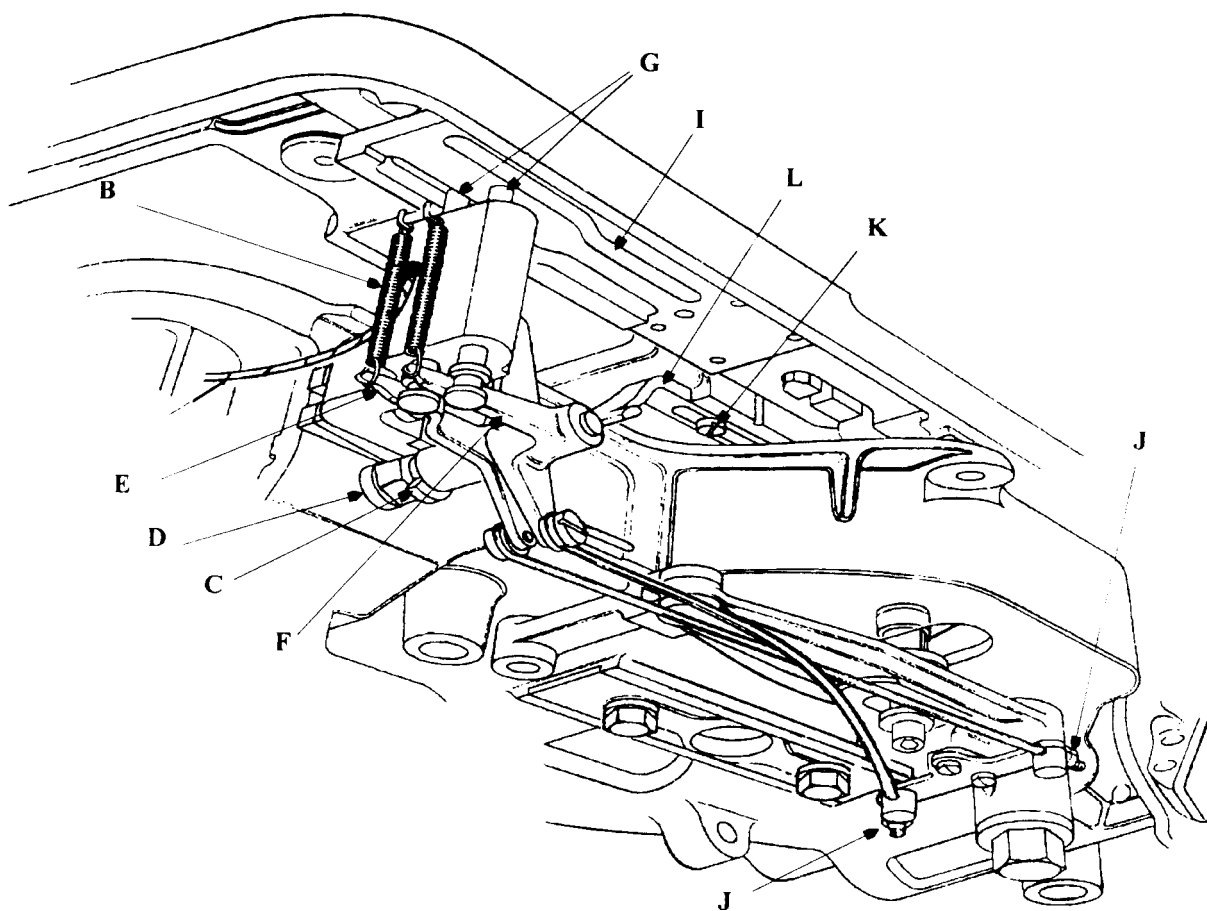

Revised 09/2004

e-mail: service@amfreece.cz; parts@amfreece.cz; website: www.amfreece.com

Phones: +420 582 309 146 (Service), +420 582 309 286 (Spare Parts); Fax: +420 582 360 606

LOOPER AND NEEDLE ALIGNMENT

1. Make sure the main power is **OFF**. Turn the left hand crank until the machine is in home position. Insert a needle. Re-install the left hand looper.
2. Turn the right hand stitch wheel until the needle aligns with the tip of the left hand looper.
3. Turn the left hand crank until machine cycles approximately 1/2 way through the 1st row of stitches. Note the distance between the needle and looper. A magnifying glass may be necessary (the distance is difficult to see with the naked eye). Continue turning the left hand crank until the machine cycles 1/2 way around the eye. Note the distance between the needle and looper. Continue turning the left hand crank until the machine cycles 1/2 way through the 2nd row of stitches. Note the distance between the needle and looper. An equal distance should be maintained at all 3 stopping points.
4. If an equal distance has not been maintained, adjust by loosening screws **A** located on needle bar cap, so they are just snug. Lightly tap the top of the needle bar to align the needle with the looper. This must be done at each of the 3 machines stopping positions as described in step 3. The starting position is with the machine 1/2 way through the 1st row of stitches.
5. Once the needle and looper are in alignment in all 3 of machine stopping positions described in step 3, re-tighten screws **A** and re-check the alignment. Repeat the above steps as necessary.

Left Hand Looper

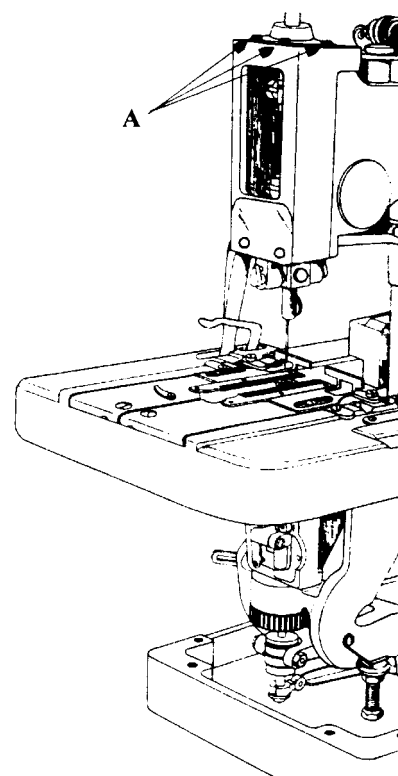
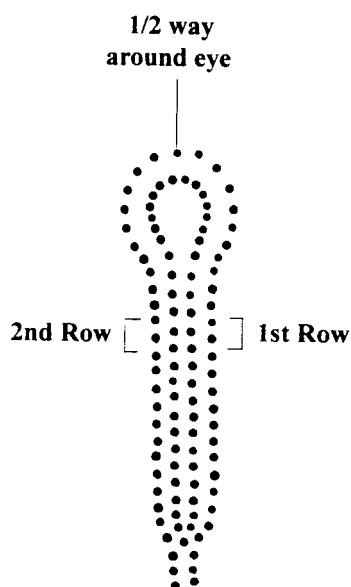
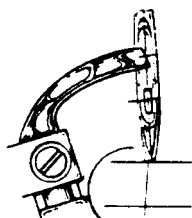

Revised 09/2004

e-mail: service@amfreece.cz; parts@amfreece.cz; website: www.amfreece.com

Phones: +420 582 309 146 (Service), +420 582 309 286 (Spare Parts); Fax: +420 582 360 606

PRICK IN

Prick-in is a method used to view the make-up of a buttonhole by creating a stitch pattern on a piece of paper before actually sewing on a garment. The result of the prick-in will be used as a benchmark for all adjustments.

1. The following are things to look for when doing a “prick-in”:

- A Eye Shape
- B Cutting Space
- C Stitch Bite
- D Length of Buttonhole
- E Length of Flybar
- F Last Stitch
- G Stitch Count
- H Position of Knives / Central Stitching

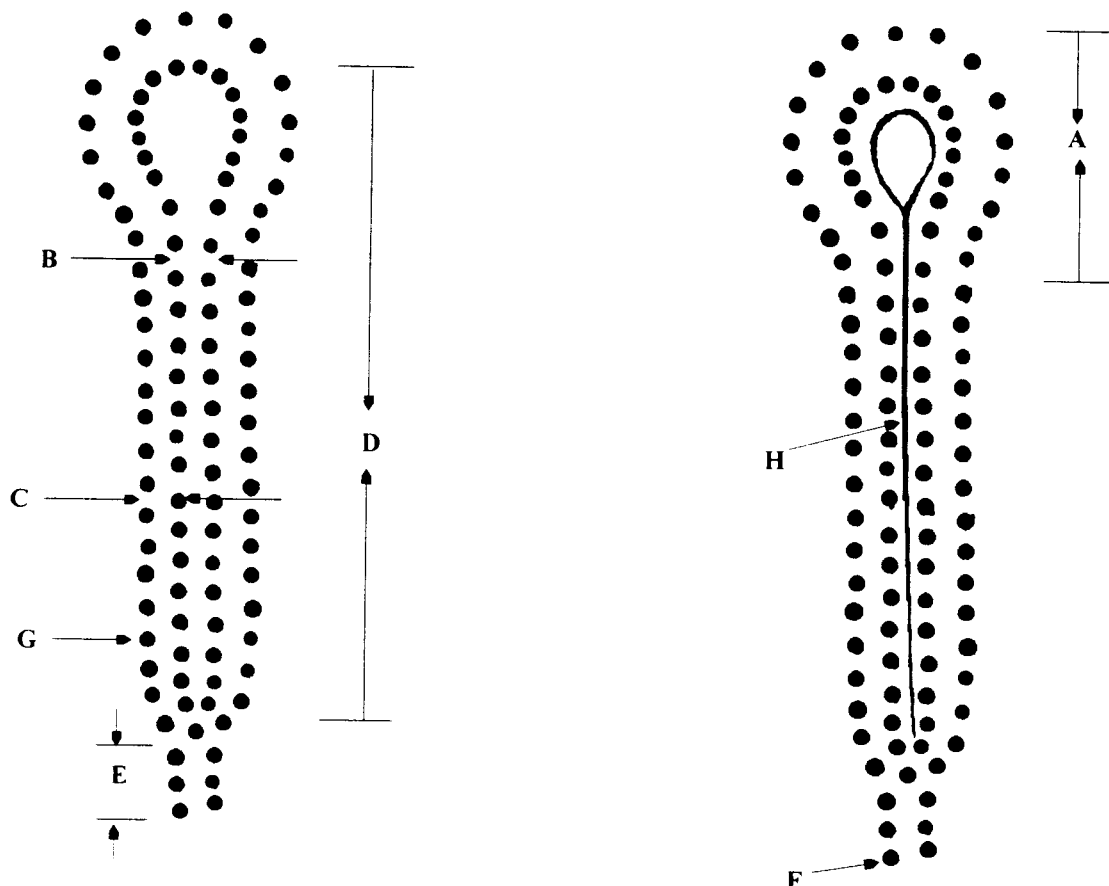

Revised 09/2004

e-mail: service@amfreece.cz; parts@amfreece.cz; website: www.amfreece.com

Phones: +420 582 309 146 (Service), +420 582 309 286 (Spare Parts); Fax: +420 582 360 606

PRICK IN

2. Install the throat plate. Insert prick-in needle 02.0001.0.000 into the needle bar. The depth of the needle into the needle bar should be set to allow just the point of the needle to penetrate the paper. Place a piece of paper across the clamp area of the bedplate.

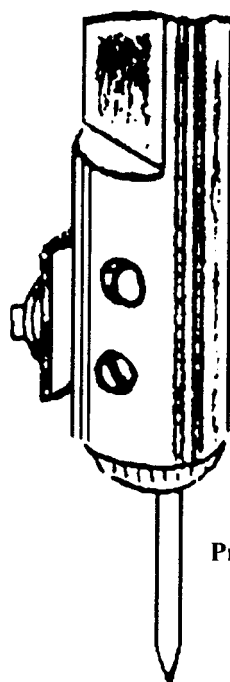

Prick-in Needle 02.0001.0.000

3. Turn the power on. Holding the piece of paper in place, cycle the machine to show the stitching pattern.

Revised 09/2004

e-mail: service@amfreece.cz; parts@amfreece.cz; website: www.amfreece.com

Phones: +420 582 309 146 (Service), +420 582 309 286 (Spare Parts); Fax: +420 582 360 606

EYESHape ADJUSTMENT

1. Looking at the newly created stitch pattern, determine which way nut **A** should be moved in order for a correct eye shape to be obtained. Use the examples below as a guide.
 2. To adjust for the eye shape, loosen nut **A** located on the combination lever **B**. Move nut up or down as necessary. If the shape of the eye looks like Example 1, move nut down; if the shape of the eye looks like Example 2, move nut up.
 3. Once the adjustment has been made, re-tighten nut **B**. Cycle the machine to ensure correct stitch pattern has been obtained. If the correct stitch pattern has not been obtained, repeat the above steps.
- NOTE:** It is not uncommon to repeat the above steps several times.

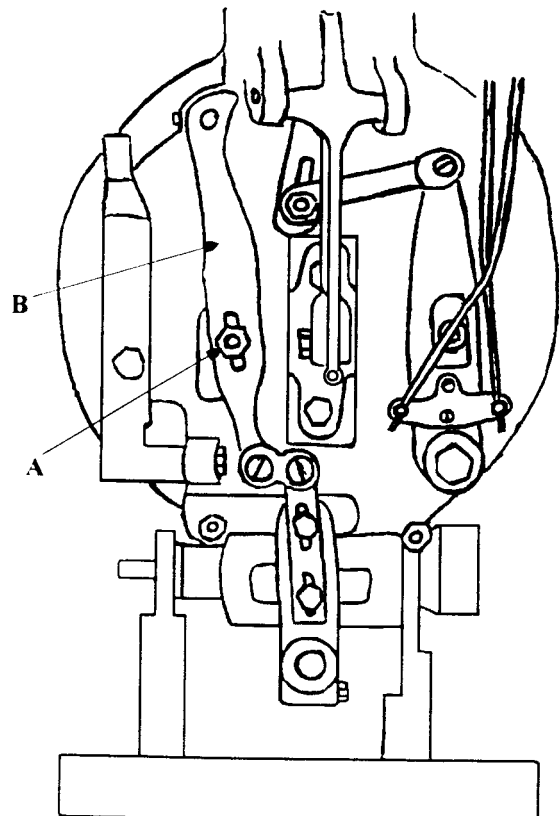
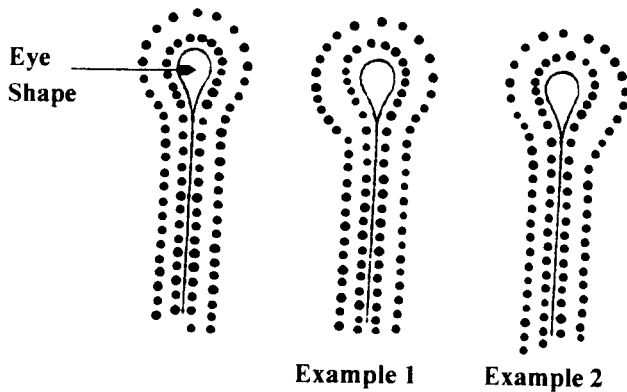

CUTTING SPACE ADJUSTMENT

Cutting space is the distance between the two rows of stitches. The distance will vary with different types of materials. The cutting space sets the boundaries for the knife when cutting the buttonhole. The proper cutting space sets these boundaries without damaging the stitches. An example of cutting space is shown below.

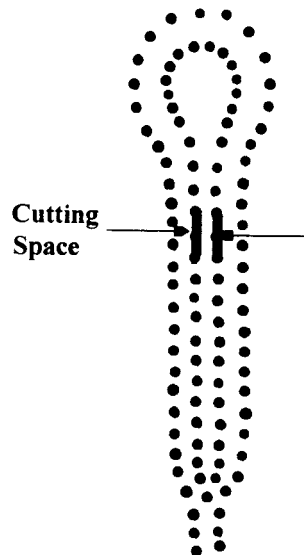

To adjust, loosen bolt A. Move bolt down for more cutting space; move the bolt up for less cutting space. Once the adjustment has been made, re-tighten nut A.

NOTE: When the cutting space is changed, the looper timing will need to be re-checked.

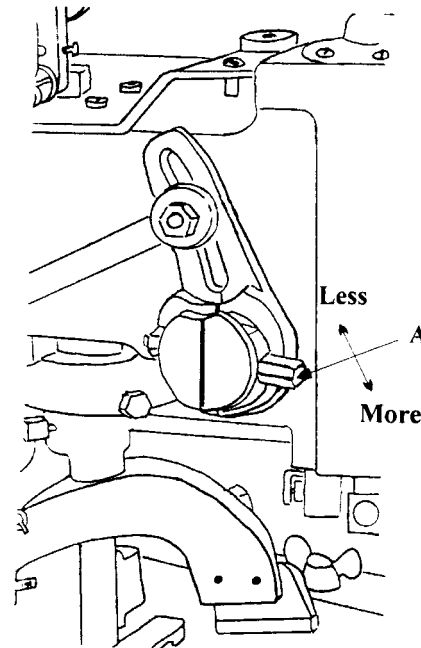

Revised 09/2004

e-mail: service@amfreece.cz; parts@amfreece.cz; website: www.amfreece.com

Phones: +420 582 309 146 (Service), +420 582 309 286 (Spare Parts); Fax: +420 582 360 606

STITCH BITE WIDTH ADJUSTMENT

The stitch bite is the width of the stitch. The width will vary with different types of materials. An example of the stitch bite is shown below.

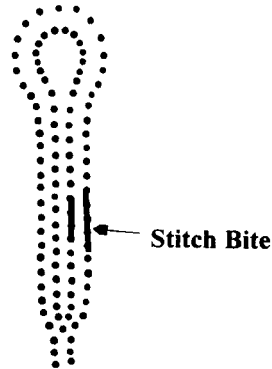

To adjust, loosen nut **A**, and move drag link **B** up or down (up decreases stitch bite; down increases stitch bite) as necessary. Once the adjustment has been made, re-tighten nut **A**.

NOTE: When setting this adjustment, check the position of the needle to the gimp hole on the throat plate. The point of the needle should be just to the right of the gimp hole. This is to ensure that the needle does not pass through the gimp during sewing. Also when the stitch bite is change, the looper timing will need to be re-checked.

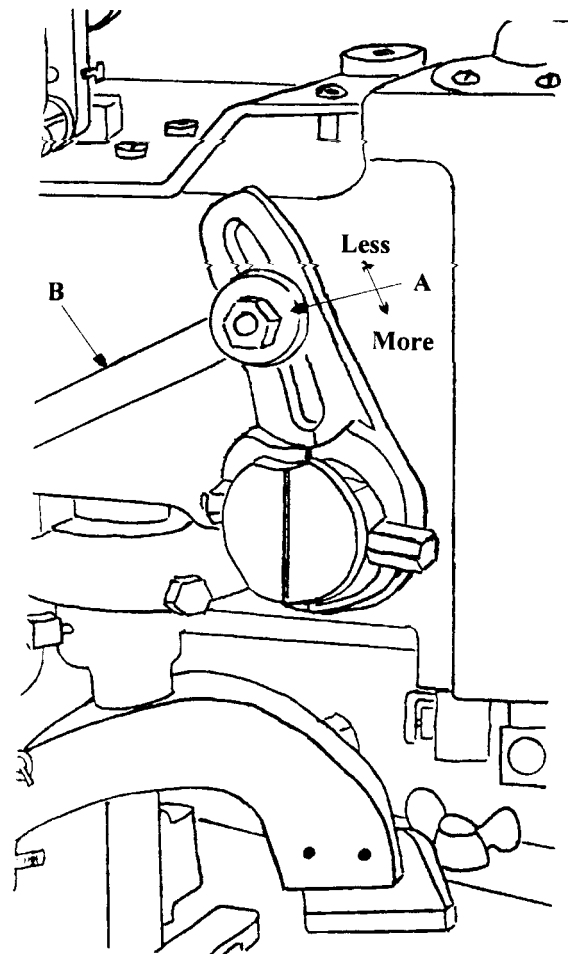

Revised 09/2004

e-mail: service@amfreece.cz; parts@amfreece.cz; website: www.amfreece.com

Phones: +420 582 309 146 (Service), +420 582 309 286 (Spare Parts); Fax: +420 582 360 606

BUTTONHOLE LENGTH ADJUSTMENT

Loosen wing nut **A**, move length gauge **B** so that it is aligned with the size of the desired buttonhole engraved on the length indicator **C**. The length indicator is used to show the length of the buttonhole. Once the adjustment has been made, re-tighten wing nut **A**.

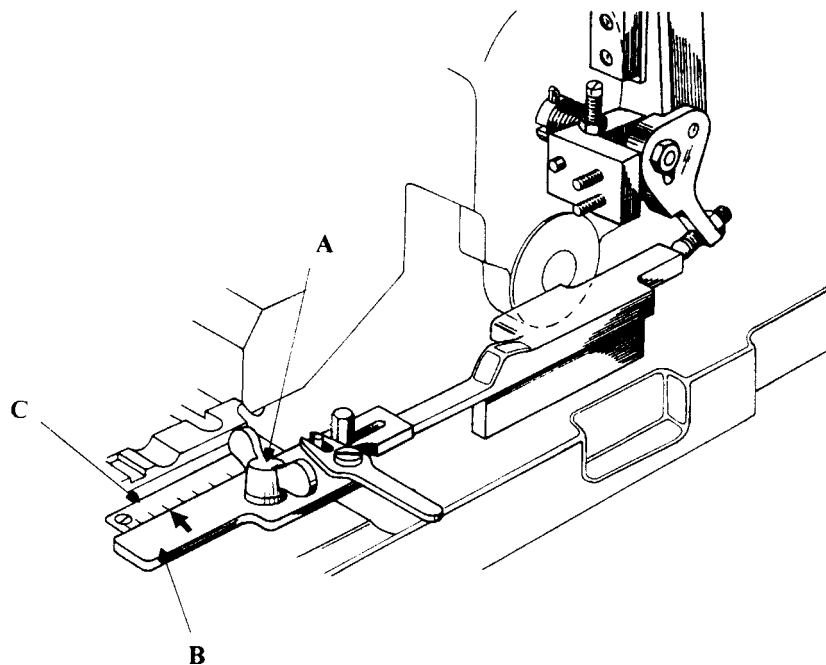
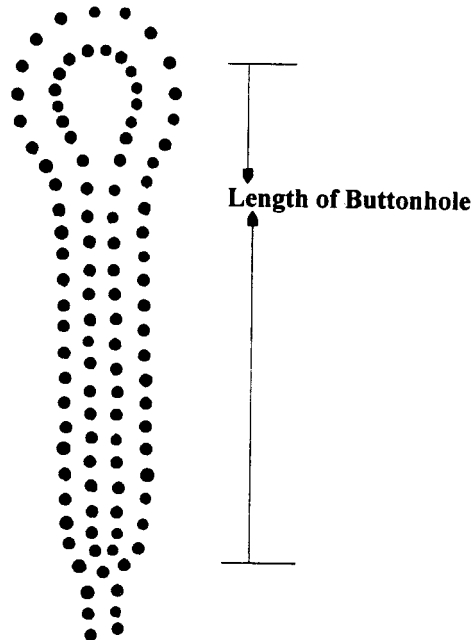

Revised 09/2004

e-mail: service@amfreece.cz; parts@amfreece.cz; website: www.amfreece.com

Phones: +420 582 309 146 (Service), +420 582 309 286 (Spare Parts); Fax: +420 582 360 606

FLYBAR ADJUSTMENT

The flybar is the position of the buttonhole where the second row of stitches crosses over the first row of stitches, as shown in the example below.

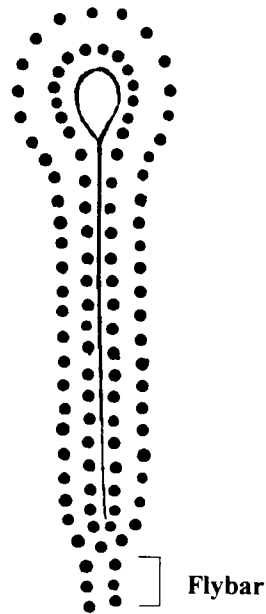

The length of the flybar can range from 0 to 3/8 of an inch. To adjust, loosen nut A, and move lever B forward or backward (move lever forward for a shorter flybar; move lever backward for a longer flybar) as necessary. Once the adjustment has been made, re-tighten nut A.

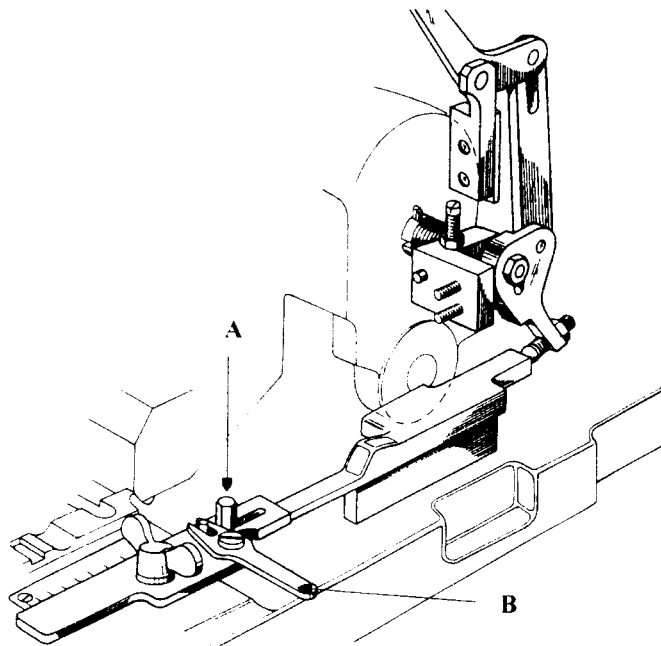

Revised 09/2004

e-mail: service@amfreece.cz; parts@amfreece.cz; website: www.amfreece.com

Phones: +420 582 309 146 (Service), +420 582 309 286 (Spare Parts); Fax: +420 582 360 606

END STITCH ADJUSTMENT

1. Loosen nut **A**. Adjust screw **B** for proper stopping by turning the screw in or out (in will make the machine stop *sooner*; out will make the machine stop *later*) as necessary.
2. Once screw **B** has been adjusted, re-tighten nut **A**.

Examples of Stitches

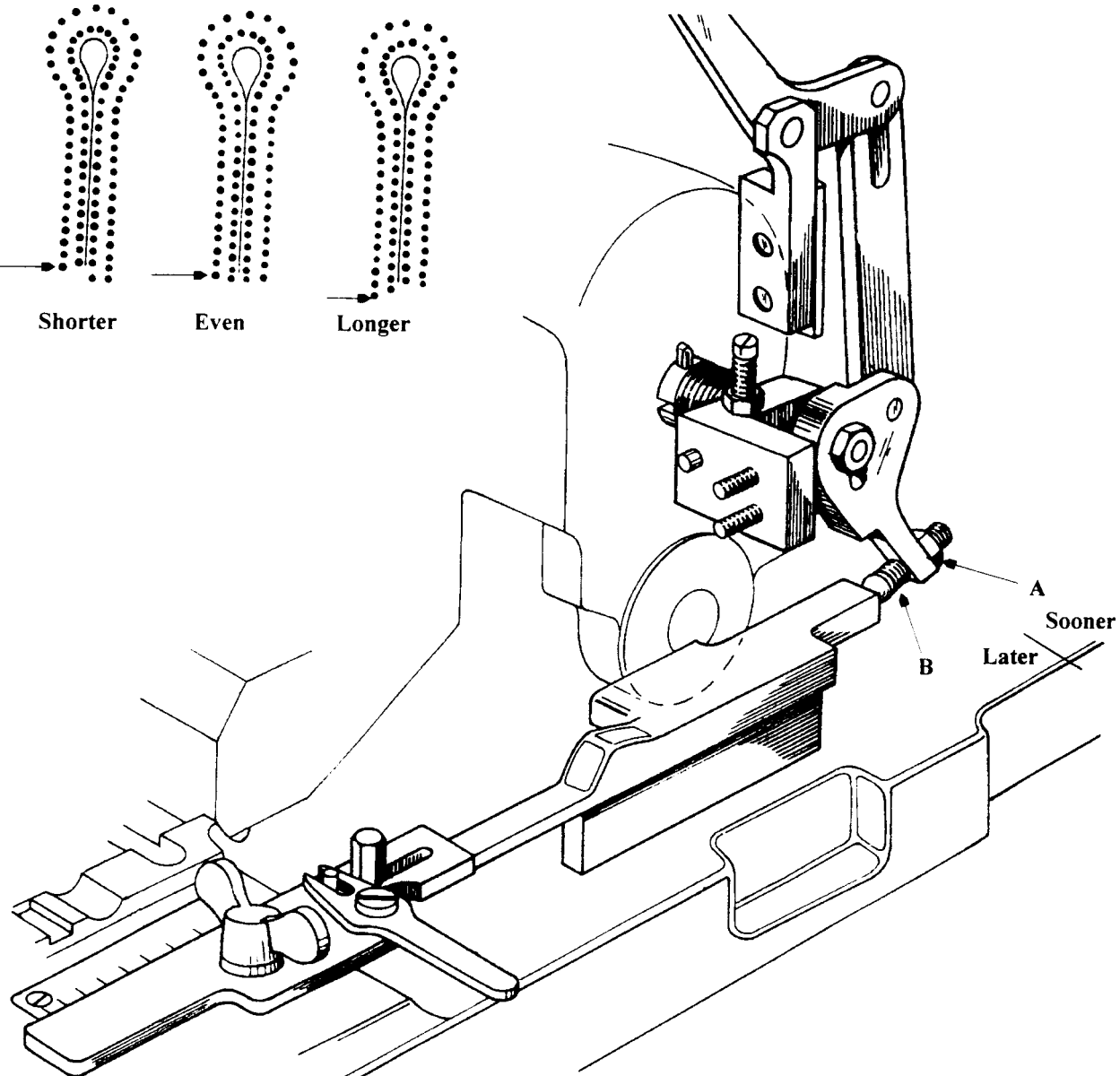
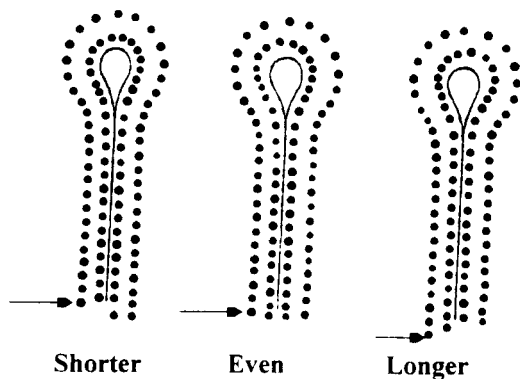

Revised 09/2004

e-mail: service@amfreece.cz; parts@amfreece.cz; website: www.amfreece.com

Phones: +420 582 309 146 (Service), +420 582 309 286 (Spare Parts); Fax: +420 582 360 606

STITCH COUNT ADJUSTMENT

To adjust the stitch count, loosen nut **A** and move slide link **B** forward or backward (forward *increases* the number of stitches; backward *decreases* the number of stitches) as necessary. Once the adjustment has been made, re-tighten nut **A**.

To *increase* or *decrease* the number of stitches in the eye portion of the buttonhole, perform the following steps:

No eye buttonholes (Adjustable Flybar Only)

Change the selector lever, located in the rear of the bedplate, to the “NO EYE” position by moving lever **C** forward to the “No Eye “ position. Loosen screw **D** and move wedge **E** forward or backward (forward increases the number of stitches, backward decreases the number of stitches.) This is done to control the descent of roll **F** on the beveled portion of the wedge while the race is turning, and the buttonhole is being sewn. Once the adjustment has been made, re-tighten screw **D**.

Eye Buttonholes (Adjustable Flybar Only)

Change the selector lever, located in the rear of bedplate, to the “Eye” position by moving the lever **C** backward to the “Eye” position. The desired number of stitches in the eye is obtained by the position of stop screw **H**. To adjust, loosen jam nut **G**, and move stop screw **H** in or out (in will increase the number of stitches; out will decrease the number of stitches). This is done to control the descent of roll **F** on the beveled portion of the wedge. Once the adjustment has been made, re-tighten jam nut **G**.

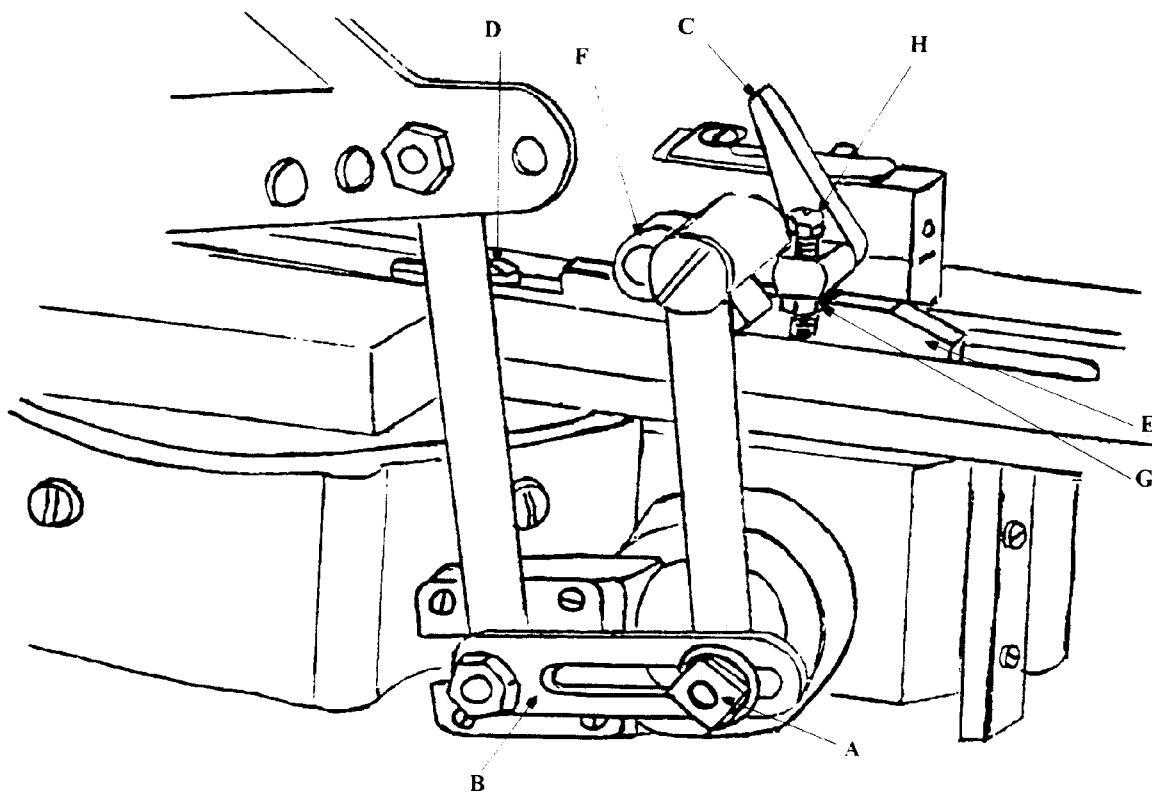

Revised 09/2004

e-mail: service@amfreece.cz; parts@amfreece.cz; website: www.amfreece.com

Phones: +420 582 309 146 (Service), +420 582 309 286 (Spare Parts); Fax: +420 582 360 606

CUTTING STEEL AND KNIFE ADJUSTMENTS

Knife and Cutting Lever Adjustment

1. Ensure cutting steel **A** is properly inserted into the cutting lever. To insert, loosen screw **D** and slide the new steel in. It must be squared with the lever and seated all the way back to the locating pin. Once the steel is in place, re-tighten screw **D**. Manually lower cutting lever **C** to ensure knife **B** and cutting steel **A** are in alignment.

NOTE: When replacing the cutting steel, back off the cutting pressure as described on page 1-57, fit the cutting steel to the machine, then re-adjust the pressure accordingly.

2. Perform “prick-in” as described on page 1-46 and 1-47. Remove cutting pressure.

3. Looking at the newly created buttonhole pattern, check to see if the knife cut is centered to buttonhole. If the knife pattern is **not** centered to the buttonhole, perform following steps:

4. Loosen nut **E**, located on both sides of the machine; using studs **F**, move cutting lever **C** to the right or left as necessary in order to center the cut to the buttonhole. Once the adjustment has been made, fasten the studs in place by re-tightening nuts **E**.

5. Once the nuts have been re-tightened, ensure cutting lever moves freely up and down, and there is no side movement.

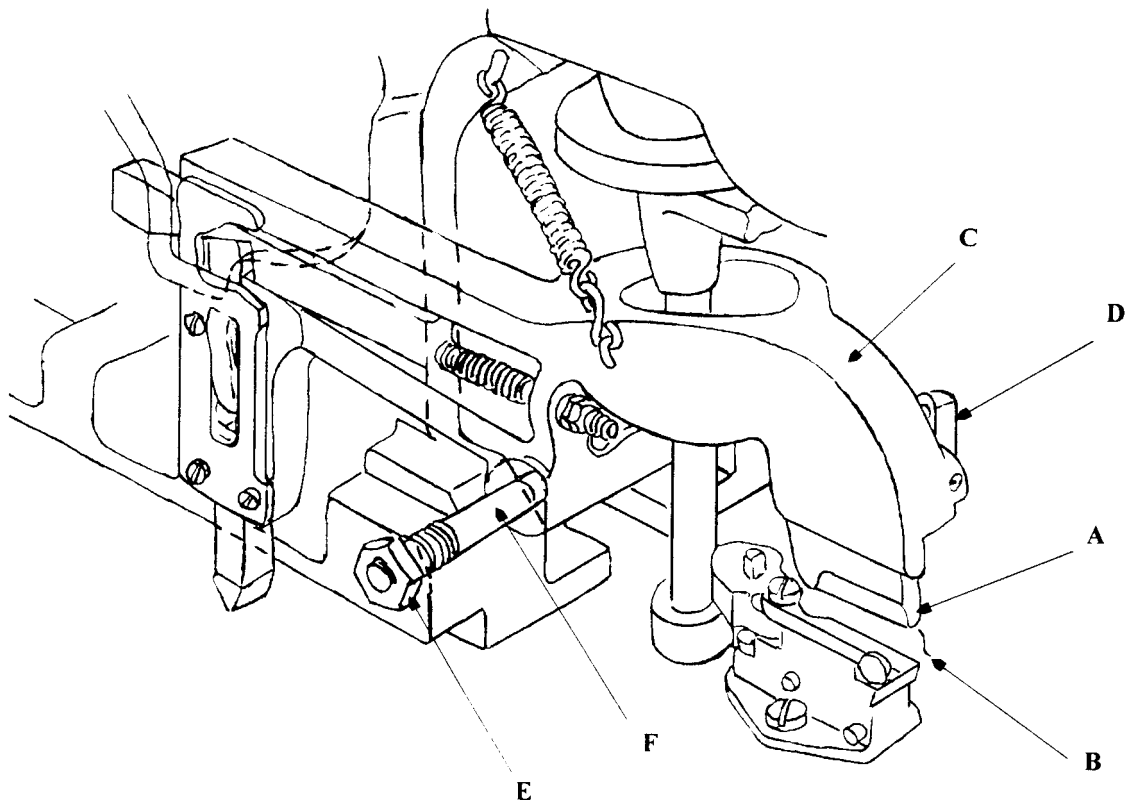

Revised 09/2004

e-mail: service@amfreece.cz; parts@amfreece.cz; website: www.amfreece.com

Phones: +420 582 309 146 (Service), +420 582 309 286 (Spare Parts); Fax: +420 582 360 606

CUTTING STEEL AND KNIFE ADJUSTMENTS

6. Knife holder **G** (with knife inserted) must line up with the center of the prick-in. If it does not, loosen screw **H** and screw **I** (located on both sides of the knife holder), and slide knife holder left or right as necessary. Once the adjustment has been made, re-tighten screw **H** and **I**.

7. The cutting lever must be in alignment with the knife. To check, manually pull the lever down. If not in alignment with the knife, repeat step 4.

NOTE: The knife must be lined up in the center of the cutting steel. The cutting lever should be free of binds and have no side play. In order to visually check the impression made by the knife onto the cutting steel, the machine may be cycled under power without stitching. This is done by raising lever **J** for a short period of time, pressing start lever, and the machine will quickly make one complete cycle. See page 1-94 for knife ordering instructions.

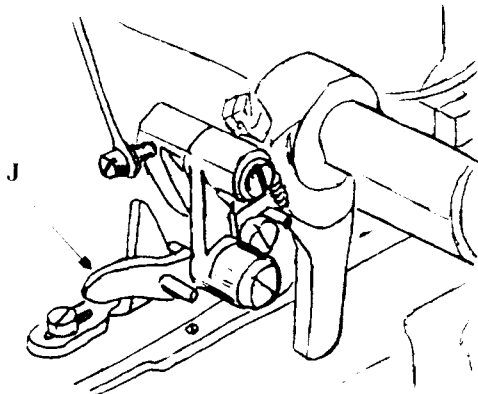
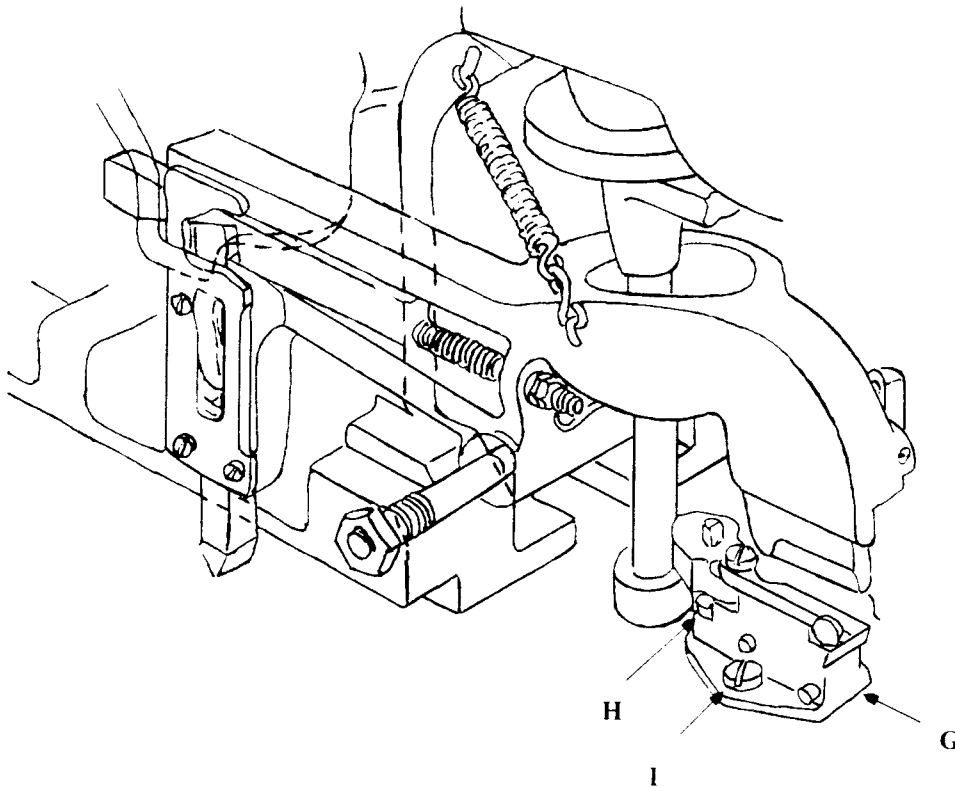

Revised 09/2004

e-mail: service@amfreece.cz; parts@amfreece.cz; website: www.amfreece.com

Phones: +420 582 309 146 (Service), +420 582 309 286 (Spare Parts); Fax: +420 582 360 606

CUTTING STEEL AND KNIFE ADJUSTMENTS

Adjusting the Cutting Pressure

The cutting pressure should be adjusted when the cutting steel is replaced or the material being sewn has been changed. To change the cutting pressure, perform the following steps.

1. Loosen jam nuts A and move in or out (in will increase the cutting pressure; out will decrease the cutting pressure) as necessary. Once the correct amount of pressure has been obtained, re-tighten nuts A.

CAUTION: The pressure should be minimized. If the pressure is too high, it can cause breakage of the castings and damage to the cutting lever, as well as the cam followers.

2. If unable to obtain adequate cutting pressure by performing step 1 above, the cutting cam follower or cutting cam may need to be replaced.

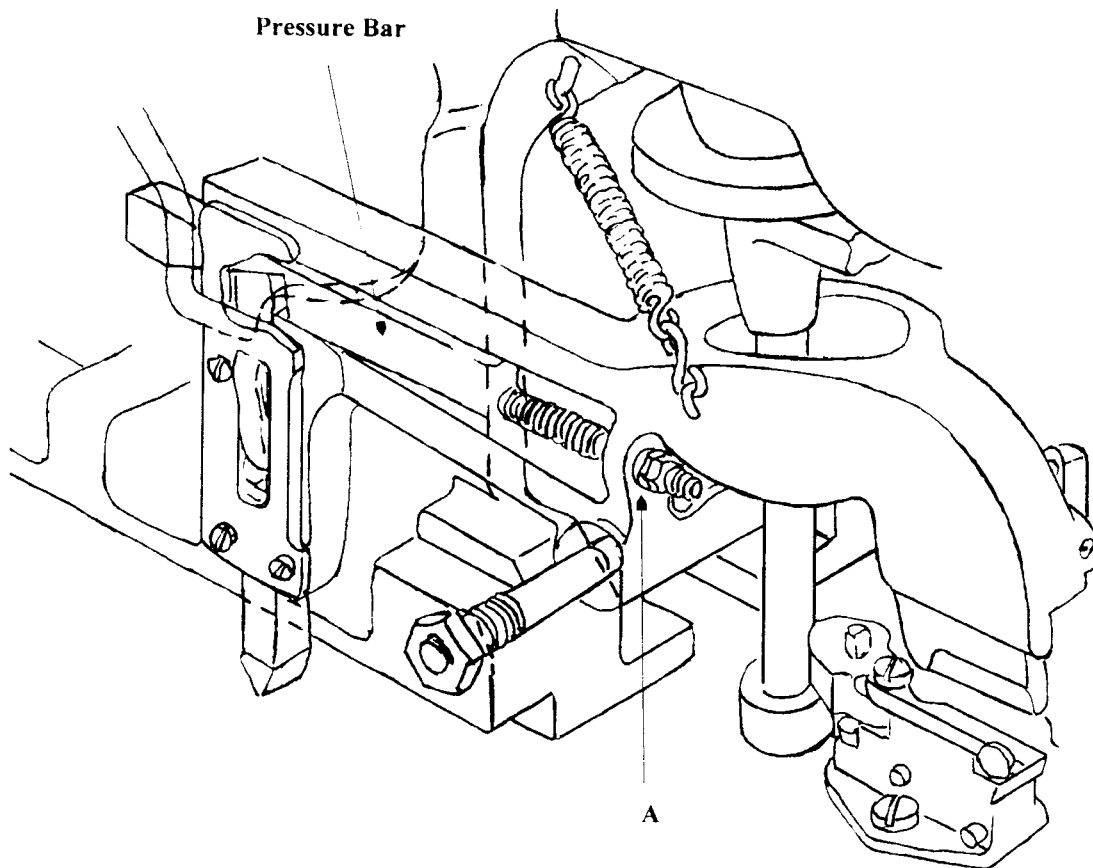

Revised 09/2004

e-mail: service@amfreece.cz; parts@amfreece.cz; website: www.amfreece.com

Phones: +420 582 309 146 (Service), +420 582 309 286 (Spare Parts); Fax: +420 582 360 606

CUTTING STEEL AND KNIFE ADJUSTMENTS

Replacing the Cutting Steel

To replace cutting steel A, perform the following steps:

1. Install cutting steel **A** into cutting lever **C** by loosening screw **D** and sliding new steel in. It must be seated all the way back to the location pin. Once the steel is in place, re-tighten screw **D**.
2. Manually lower cutting lever **C** to ensure cutting steel **A** is centered over knife **E**. If it is not centered, loosen nuts **F**, located on both sides of the machine; using studs **G**, move cutting lever **C** to the right or left as necessary. The cutting lever should be free of binds and have no side play. Once the adjustment has been made, fasten the studs in place by re-tightening nuts **F**.
3. Back off the cutting pressure until a light pressure is felt when cutting steel **A** meets knife **E**. This is done by loosening jam nuts **B**, moving nuts out to decrease the cutting pressure (move nuts in to increase the cutting pressure), and turning the left hand crank to cycle machine,, checking for the slight pressure between the cutting steel and knife.
4. It is important to visually check the impression made by the knife onto the cutting steel. The impression is made by cycling the machine under power without stitching. This is done by turning on the main power, raising lever **H**, and pressing the start lever. Lever **H** should be held for approximately 1/2 of a cycle. The machine will make one complete cycle without stitching. Repeat for 5 cycles. Turn off the main power.
5. Remove cutting steel **A** and inspect the impression on the bottom surface of the steel made by knife **E**. Lightly file any high spots on the cutting steel until an **even** impression is former representing the entire length of the knife. When an uneven impression has been formed, the high spot is the area on the cutting steel which left the impression. This is the area of the cutting steel which touched the knife. The low spot of a cutting is where the impression can not be seen because it never touched the knife. The low spot should not be filed. Steps 4 and 5 may need to be repeated until the desired impression is achieved.
6. Once the desired impression has been achieved, re-install the cutting steel and adjust the cutting pressure (see step 3) until the cut of the fabric is clean.

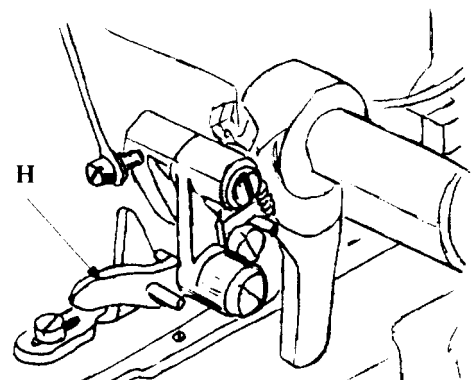
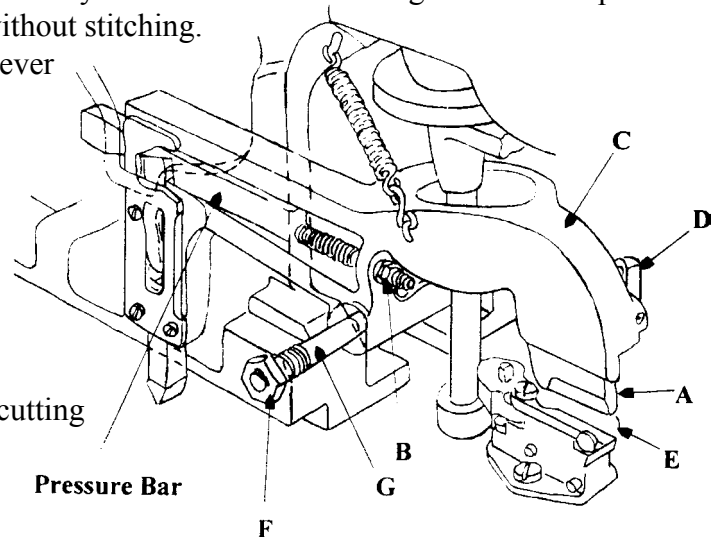

NOTE: See page 1-94 for ordering instructions.

Revised 09/2004

CLAMPING

Alignment of Clamp Plates to Bedplate

1. Make sure the machine is in the home position.
2. Install clamp plates **A**, making sure that the clamp plates are parallel to the bedplate on both sides. If they are not, perform steps 3 through 5.
3. Loosen screw **B** on outstop **C**, and screw **D** on instop **E**.
4. Manually push the right clamp towards the side of the bedplate. To adjust, loosen post **F**, slide it to the right or left as necessary. Once the adjustment has been made, re-tighten post **F**.
5. Repeat steps 3 and 4 for the other clamp.

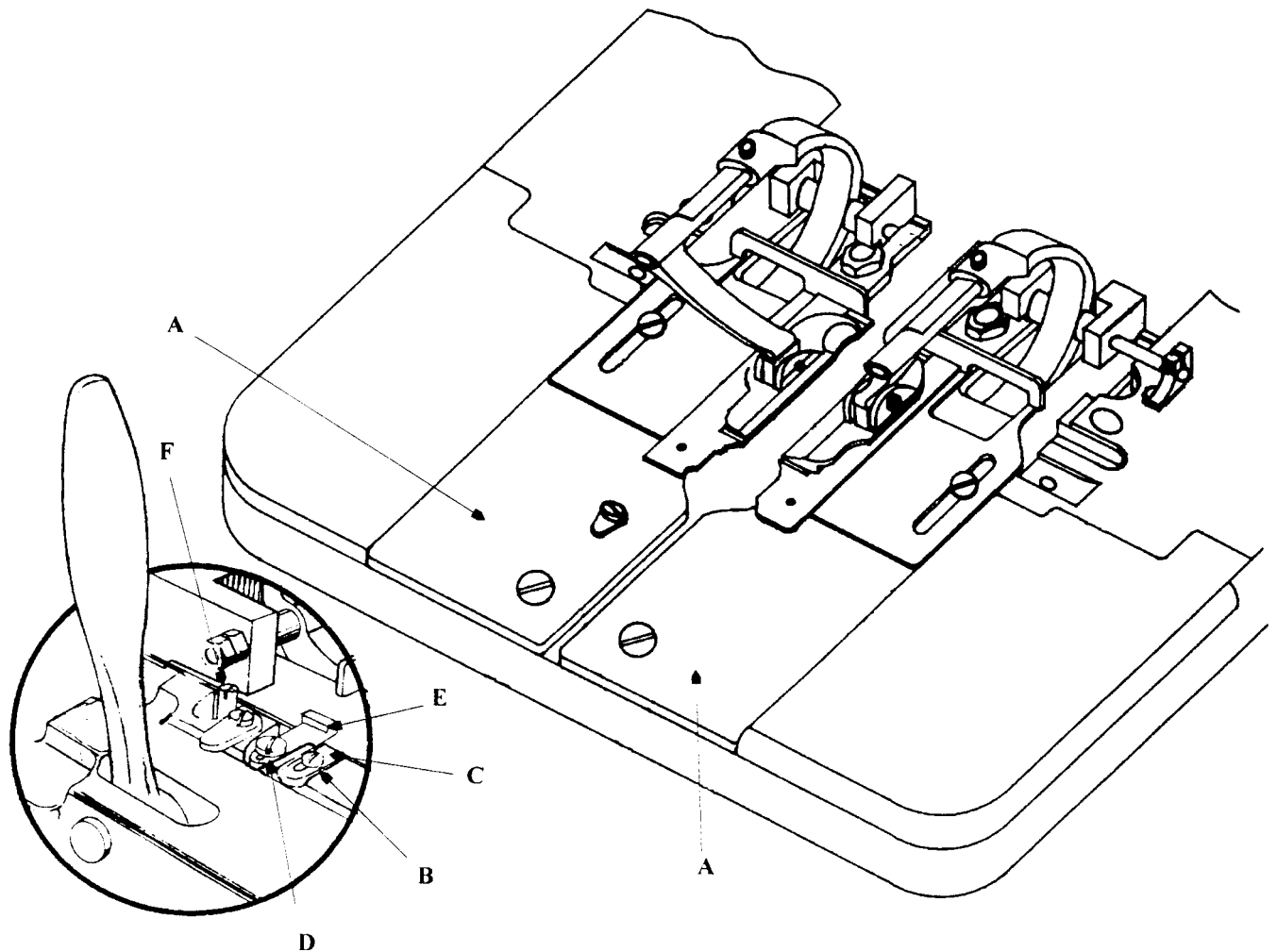

Revised 09/2004

e-mail: service@amfreece.cz; parts@amfreece.cz; website: www.amfreece.com

Phones: +420 582 309 146 (Service), +420 582 309 286 (Spare Parts); Fax: +420 582 360 606

CLAMPING

Adjusting the Clamp Plate Spread

1. Turn the left hand crank until the rollers on clamp plates **A** are positioned to the widest part of spreader block **G**, which is located on the rear of the knife holder. Move the clamp plates side to side in order to center them to the middle of bedplate.
2. Gently press outstop **C** against the side face of clamp plate **A**, and re-tighten screw **B**.
3. Repeat steps 1 and 2 for the other clamp.

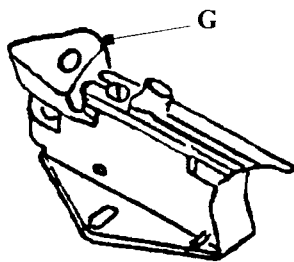

Knife Holder

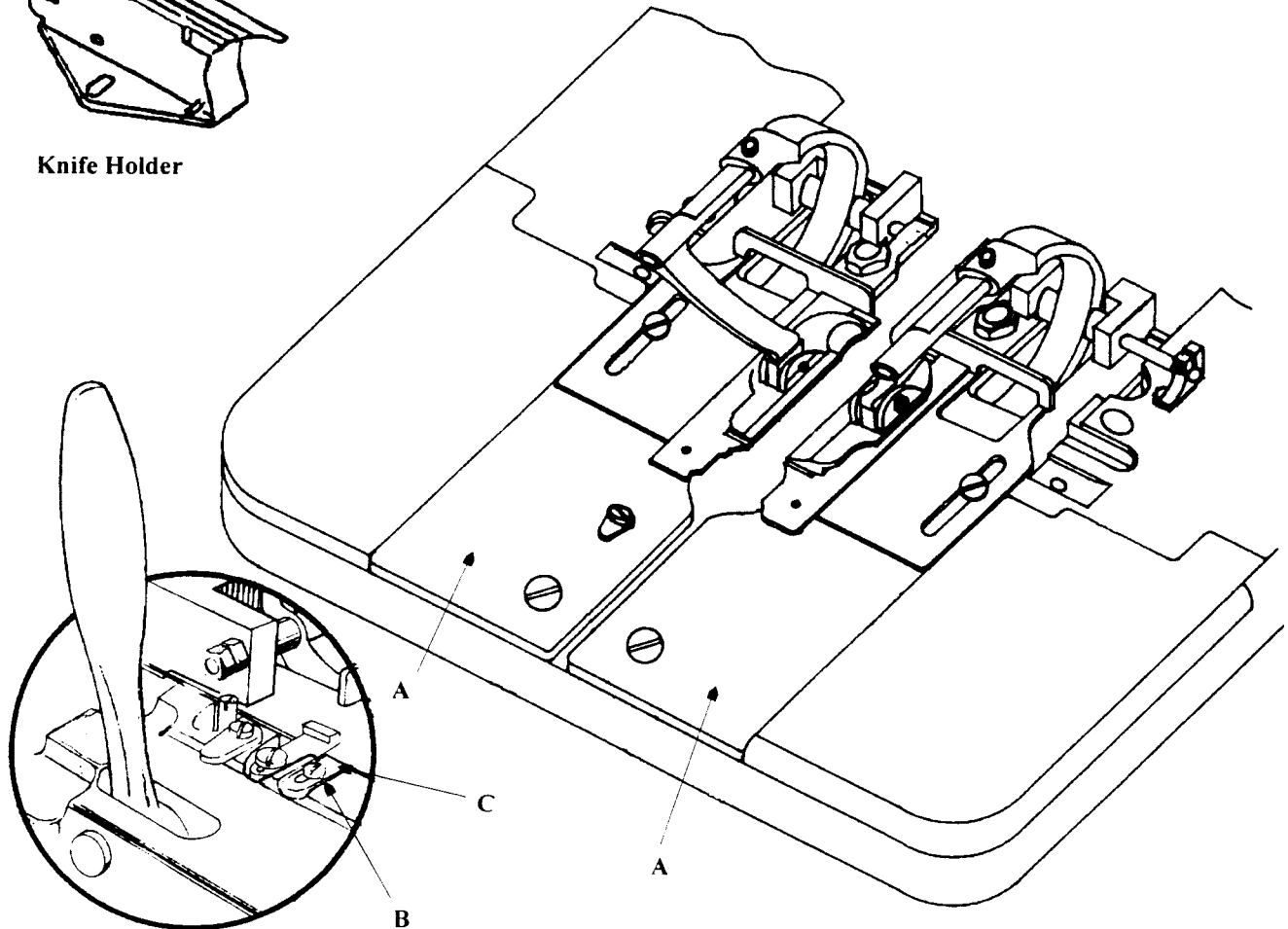

Revised 09/2004

e-mail: service@amfreece.cz; parts@amfreece.cz; website: www.amfreece.com

Phones: +420 582 309 146 (Service), +420 582 309 286 (Spare Parts); Fax: +420 582 360 606

CLAMPING

Setting the Spread of the Clamp Plates

The distance of the spread will be determined by the sewing application. The standard clearance between the edge of clamp plate **A** and outstop **C** is 0.76 mm (.030"). To adjust, perform the following steps:

1. Turn the left hand crank so that the clamp rolls are not resting on the spreader block. Place the feeler gauge between the edge of clamp plate **A** and outstop **C**. Slide the clamp plate towards the outstop until it can no longer move. Holding the clamp plate against the feeler gauge using a screwdriver, slide instop **E** outward. Once the instop is over as far as it will go, tighten screw **D**. Once the clearance has been obtained, remove the feeler gauge.
2. Repeat step 1 to obtain clearance between the other clamp plate and the outstop.

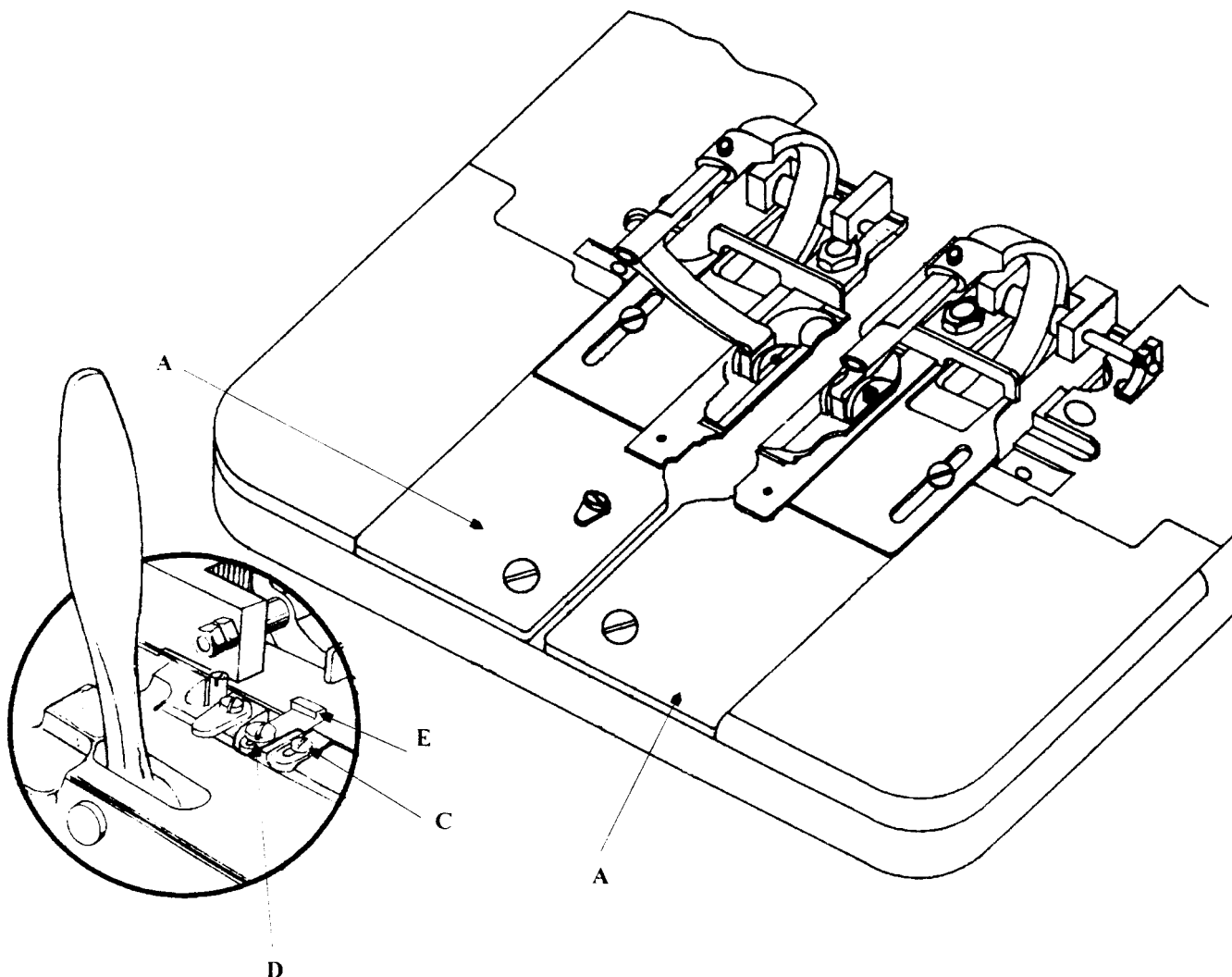

Revised 09/2004

e-mail: service@amfreece.cz; parts@amfreece.cz; website: www.amfreece.com

Phones: +420 582 309 146 (Service), +420 582 309 286 (Spare Parts); Fax: +420 582 360 606

CLAMPING

Spread Locking

As the clamps are brought down, the spread locks compress the spread locking pins. As the clamps move outward to their maximum spread, the locks move along with the clamp plates. This allows the pins to release, locking the clamps in position until they are released.

1. Turn the left hand crank until the rollers on the clamp plate are at the widest part of the spreader block (see page 1-61).
2. Engage clamps **A** by pulling clamp lever **H** forward. Slide the clamp plates toward outstop **C**. Spread locks **I** should just be touching the flat side of locking pin **J**, without restricting the movement of the locking pin. To adjust, loosen screw **K** and move spread locks **I** in or out as necessary. Once the adjustment has been made, re-tighten screw **K**.

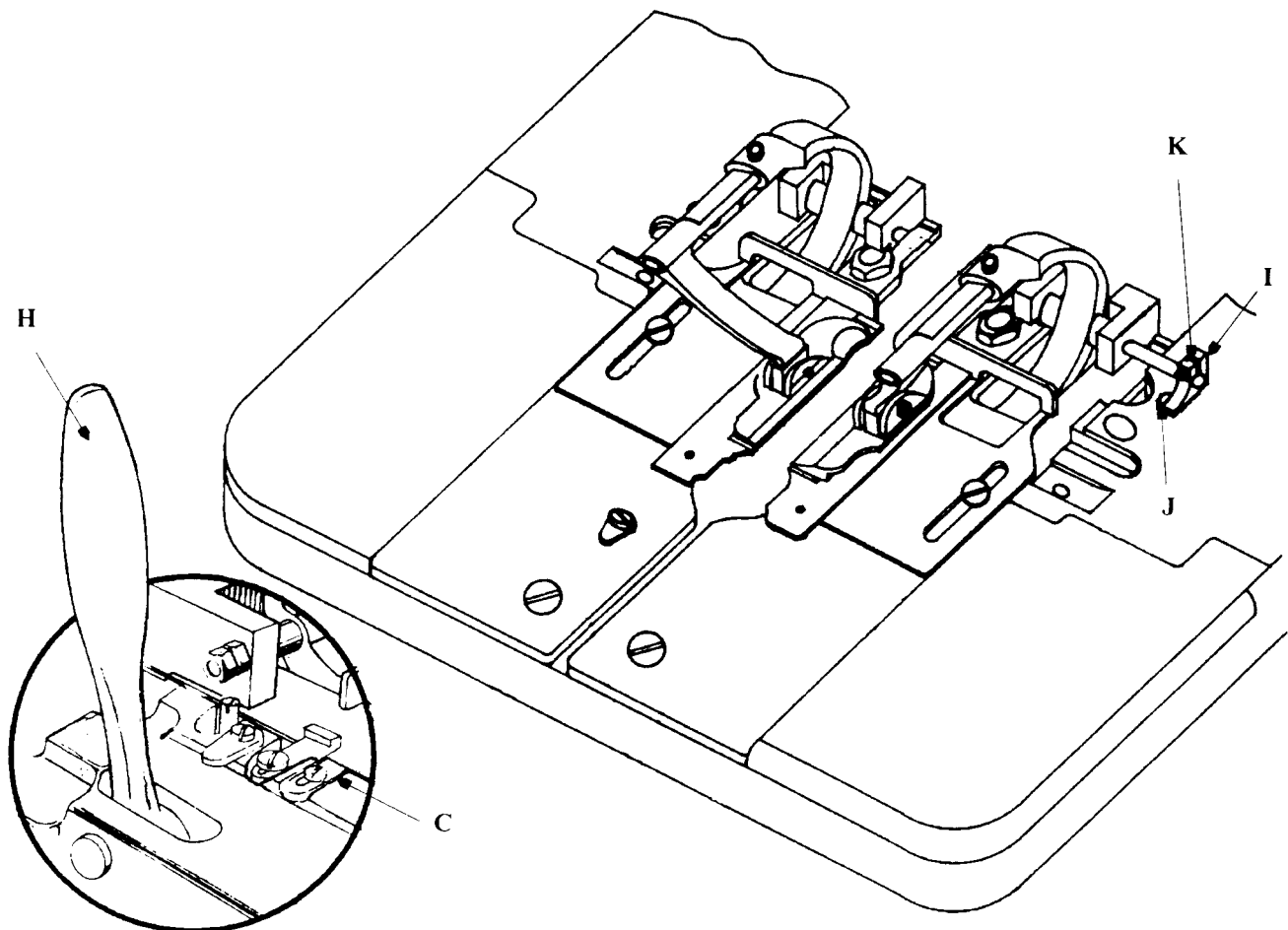

Revised 09/2004

e-mail: service@amfreece.cz; parts@amfreece.cz; website: www.amfreece.com

Phones: +420 582 309 146 (Service), +420 582 309 286 (Spare Parts); Fax: +420 582 360 606

CLAMPING

Adjusting the Clamp Pressure

The clamp foot pressure has been factory set for medium / heavy weight materials. Additional pressure may be required for light weight materials. To adjust, perform the following steps:

1. Loosen nut **A**, **B** and turn adjustment screw **C** up or down (up increases clamp pressure; down decreases clamp pressure) as necessary.
2. The correct amount of pressure is obtained when the material is held firmly by the clamp foot. Once this has been achieved, re-tighten nuts **A** and **B**.

CAUTION: Avoid using excessive pressure.

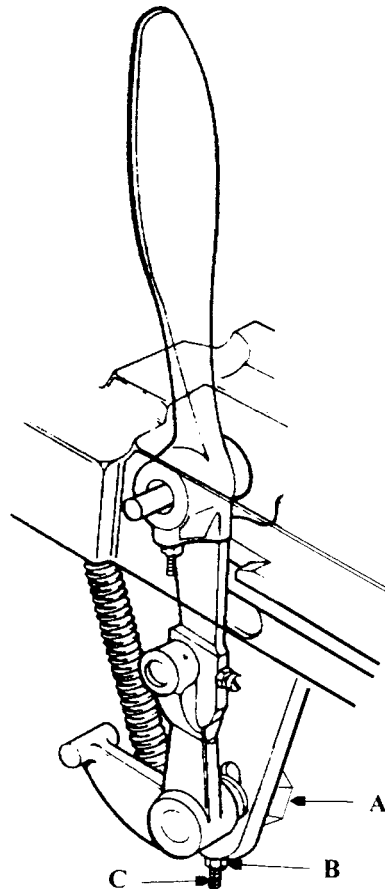

Revised 09/2004

e-mail: service@amfreece.cz; parts@amfreece.cz; website: www.amfreece.com

Phones: +420 582 309 146 (Service), +420 582 309 286 (Spare Parts); Fax: +420 582 360 606

CLAMPING

Clamp Foot Position and Needle Entry Point

The clamp feet must be adjusted so the needle is not allowed to strike the clamp foot on the right hand stroke of the needle bar. To adjust, loosen screw A in mounting base B of clamp arm C. Move the mounting base of the clamp arm in either direction 1 or 2 (moving the mounting base in direction 1 will decrease the distance between the needle and the clamp foot; moving it in direction 2 will increase the distance). Once the adjustment has been made, fasten the mounting base of the clamp arm in place.

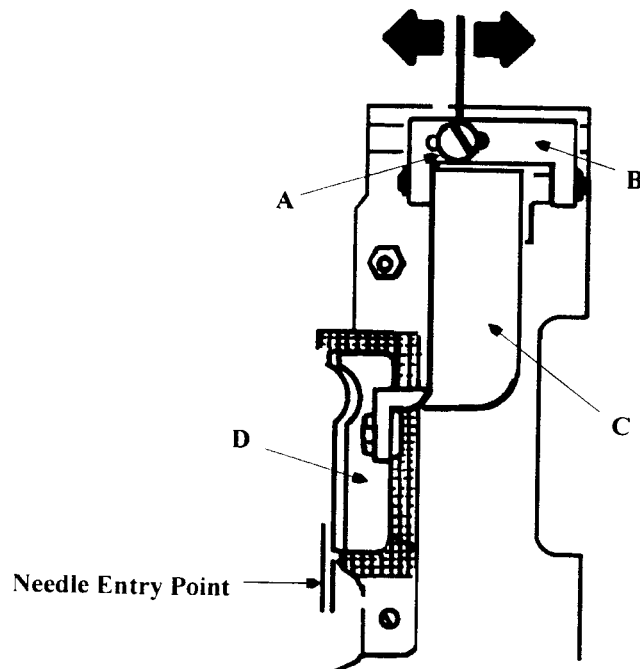

Revised 09/2004

e-mail: service@amfreece.cz; parts@amfreece.cz; website: www.amfreece.com

Phones: +420 582 309 146 (Service), +420 582 309 286 (Spare Parts); Fax: +420 582 360 606

CLAMPING

Disengagement of Clamp Arms

Disengagement of the clamps is automatic when the machine is under power. If the clamps are not disengaging properly, check the clearance between toggle lever **A** and clamp arm tip **B**. The clearance should be 0.40 mm (.016"). To adjust, perform the following steps:

Turn the left hand crank until the cutting lever and the trimming action have been completed. Continue turning the left hand crank until the bedplate stops traveling, however before it reaches the home position. Loosen nut **D**, and move clamp arm **C** backward or forward as necessary. Once the proper clearance has been maintained, re-tighten nut **D**.

NOTE: The clamp arms **MUST** disengage before the shearing action occurs. If they don't, repeat the above steps.

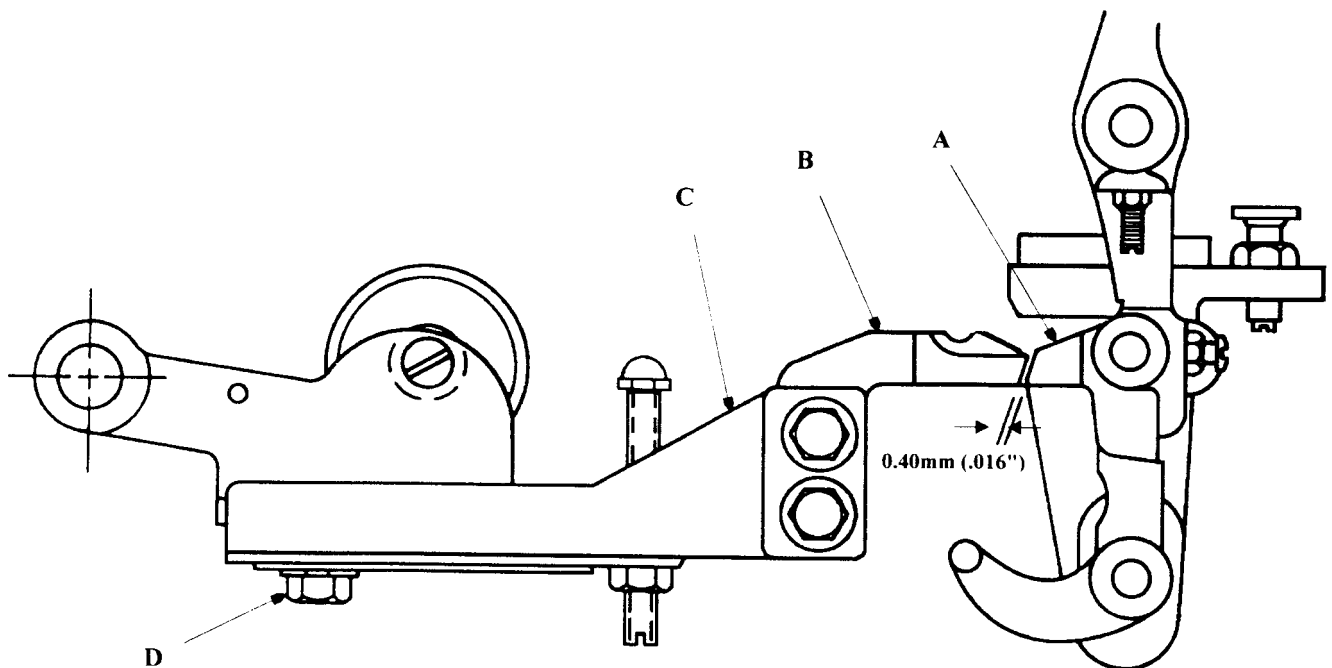

Revised 09/2004

e-mail: service@amfreece.cz; parts@amfreece.cz; website: www.amfreece.com

Phones: +420 582 309 146 (Service), +420 582 309 286 (Spare Parts); Fax: +420 582 360 606

CLAMPING

Engagement of Clamp Arms

The engagement of the clamp is automatic when the machine is under power. The clamps engage when the tip of the clamping lever pushes down on the toggle lever, which in turn locks the clamps in place for sewing. To adjust, perform the following steps:

1. Turn the left hand crank until machine is in home position. Manually bring down the clamps by pulling lever **D** forward.
2. Continue to turn the left hand crank until the under side of clamping arm tip **B** engages with lower end of toggle lever **A**. This should happen without binding the machine. If this causes binding, or clamp arm does not engage with toggle lever, loosen screws **C** and move clamp arm tip **B** up or down as necessary. Once the adjustment has been made, re-tighten screw **C**.

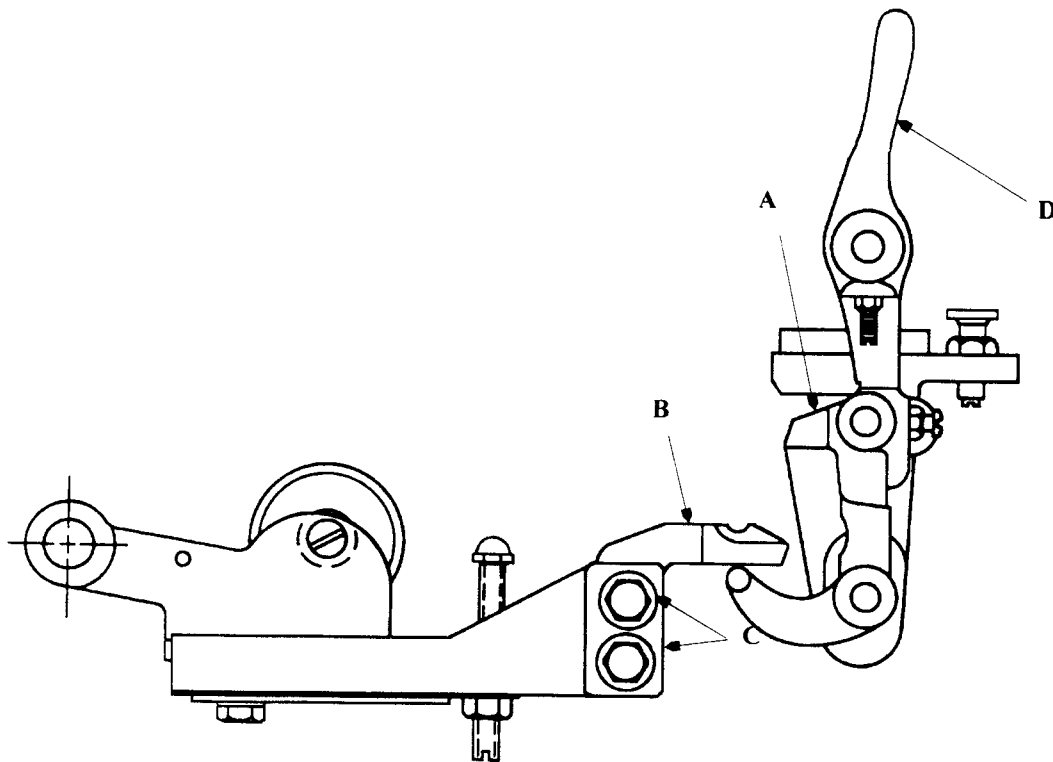

Revised 09/2004

e-mail: service@amfreece.cz; parts@amfreece.cz; website: www.amfreece.com

Phones: +420 582 309 146 (Service), +420 582 309 286 (Spare Parts); Fax: +420 582 360 606

CLAMPING

Unclamping for CB/CA

1. Lift the machine. In the CA position, turn the left hand crank until the cutting lever starts its downward movement, and the bedplate has stopped moving. The unclamping wedge located on the main cam will drive clamp lever assembly **A** down. As it returns upward, it will lift safety latch **B** up and out of the way.
2. A clearance of 0.40 mm (.016") must be maintained between clamping arm tip **C** and toggle lever **D**. To adjust, loosen bolt **E** and screws **F**, move clamp lever assembly **A** forward or backward as necessary. Holding clamp lever assembly **A** in place, move slide **G** to the rear of the machine until elongated slot comes in contact with bolt **E**. Once the above adjustments have been made, re-tighten screws **F** and bolt **E**.

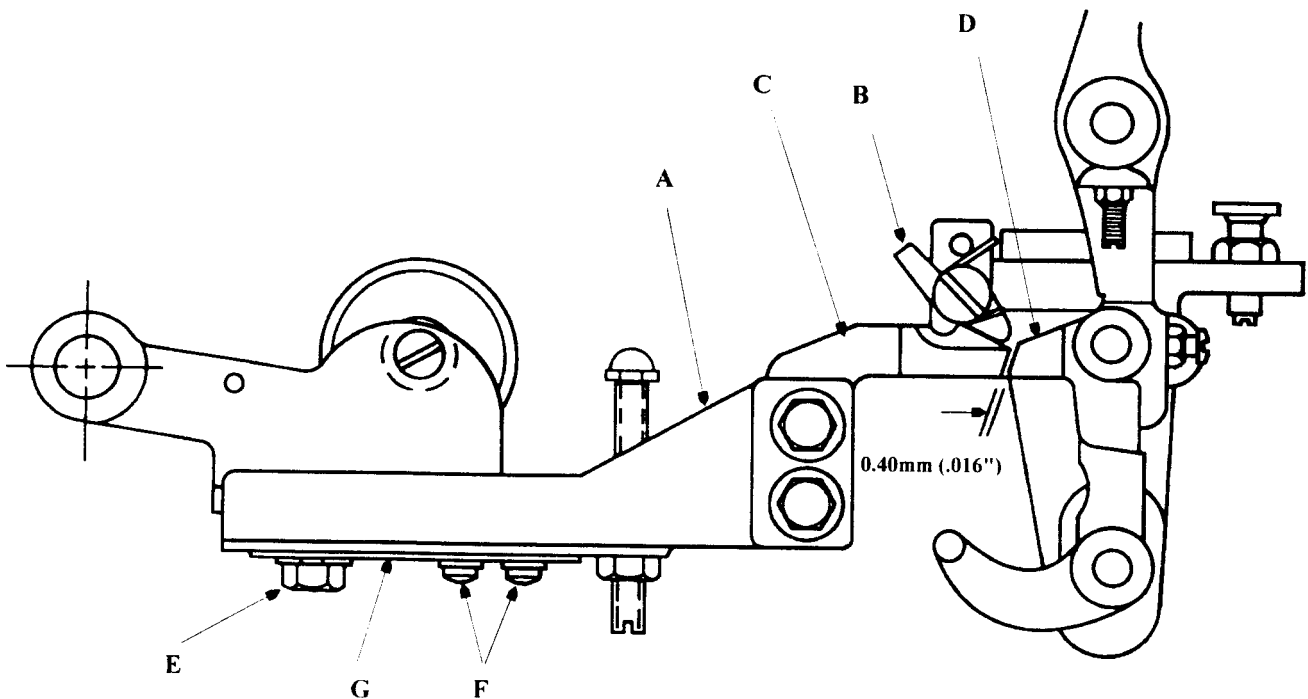

Revised 09/2004

e-mail: service@amfreece.cz; parts@amfreece.cz; website: www.amfreece.com

Phones: +420 582 309 146 (Service), +420 582 309 286 (Spare Parts); Fax: +420 582 360 606

CLAMPING

Clamping Pressure for CB/CA

In addition to adjusting the pressure as described on page 1-63, it may be necessary to adjust clamping arm tip A in order to balance the clamping pressure between CB and CA. To adjust, loosen screws B and position clamping arm tip A up or down as necessary, in order to produce a light toggle clamp force. Once the adjustment has been made, re-tighten screws B.

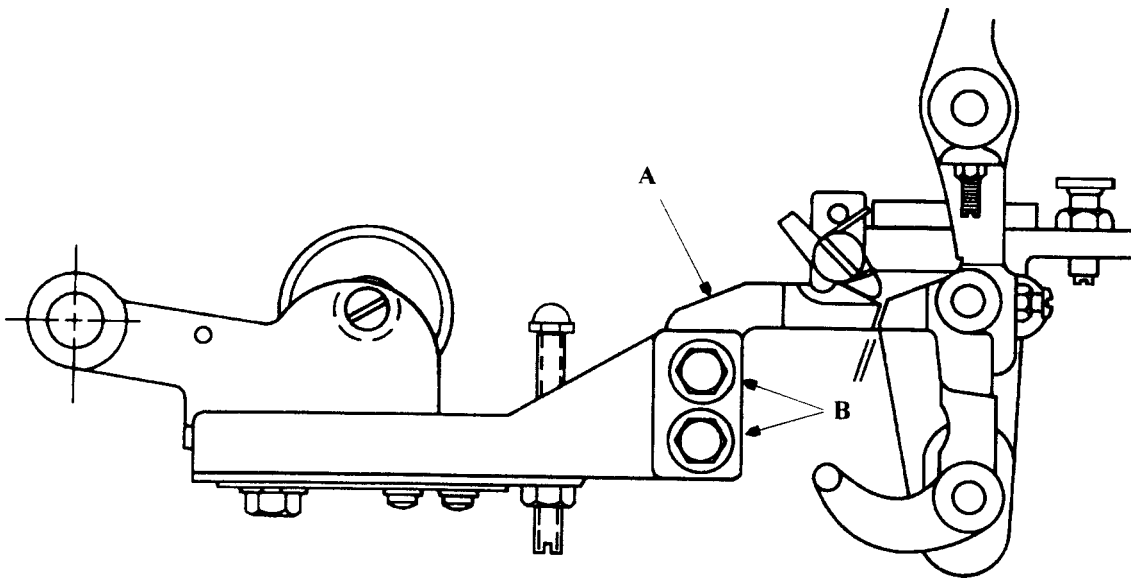

CLAMPING

Adjustment of the Safety Latch

1. Turn the left hand crank. As the machine reaches home position and the clamps disengage, safety latch **A** should fit into notch located on clamp tip **B**. To adjust, loosen screws **C** and slide bracket **E** backward or forward as necessary in order to position safety latch **A** to fit into notch. Once the adjustment has been made, re-tighten screws **C**.
2. A minimum clearance of 0.79 mm (.031") is required between toggle lever and clamp arm tip. To adjust, loosen screws **C** and turn eccentric nut **D** as necessary. Once the adjustment has been made, re-tighten screws **C**.

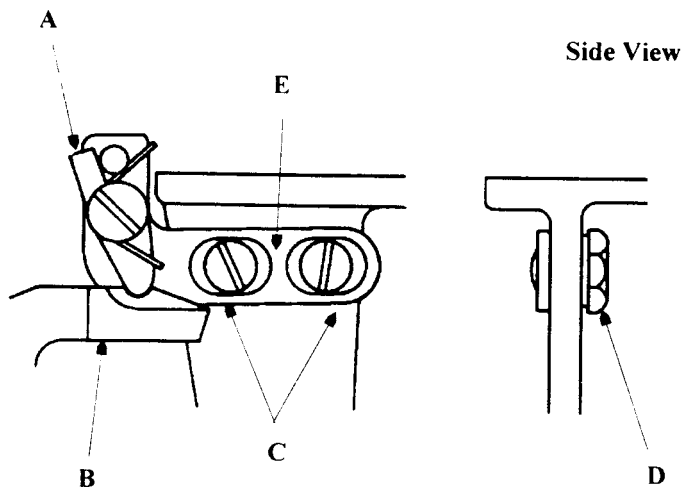

Revised 09/2004

e-mail: service@amfreece.cz; parts@amfreece.cz; website: www.amfreece.com

Phones: +420 582 309 146 (Service), +420 582 309 286 (Spare Parts); Fax: +420 582 360 606

LOOPERS AND SPREADERS

Adjusting the Needle Bar Height

The needle bar setting is standard to most threads and materials. However, changes to the needle bar height may be required when certain materials and threads are used.

1. Remove the throat plate. Turn the left hand crank until the right hand stop wheel releases.
2. Bring needle bar **A** down to its lowest point of the stroke by turning right hand stop wheel counter-clockwise. Set needle bar height to $7/32''$ by loosening screws **B** and moving needle bar up or down as necessary. Once the adjustment has been made, re-tighten screws **B**.

NOTE: After screws are tightened, make sure there is no play between nuts **C** and gimble **D**.

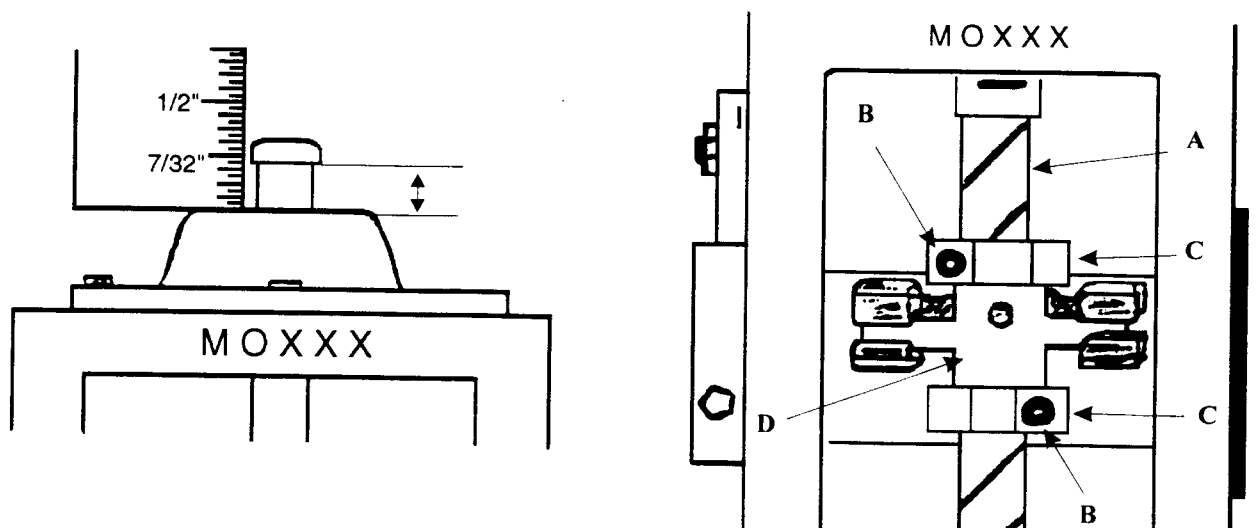

3. Bring needle bar up to its highest point, re-install the throat plate and insert a needle. Lower needle bar, checking position of the needle to gimp hole in throat plate. Needle should pass just to the right of the gimp hole on the right hand stroke of the needle bar. If adjustment is required, refer to stitch bite adjustment on page 1-50.

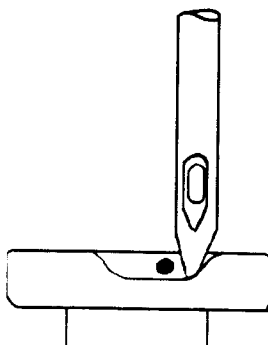

Revised 09/2004

e-mail: service@amfreece.cz; parts@amfreece.cz; website: www.amfreece.com

Phones: +420 582 309 146 (Service), +420 582 309 286 (Spare Parts); Fax: +420 582 360 606

LOOPERS AND SPREADERS

Adjusting Clearance between Loopers and Needle

Before performing the following adjustment, ensure the looper and needle are in alignment (see page 1-45), the throat plate has been removed and the right and left looper have been installed.

To install the loopers, loosen screws **B** and **C**. Install the loopers. Do not re-tighten screws at this time.

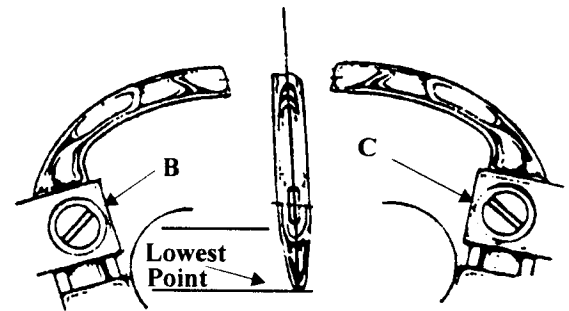

1. Turn the right hand stop wheel counterclockwise, bringing needle bar down to its lowest point.

2. Loosen screw **A** located on the back side of the race. Move the looper carrier to the right until it reaches the center of the needle. Re-tighten screw **B** slightly. The left hand looper and the needle must have a clearance of between 0.03 and 0.11 mm (.001 and .004"). To adjust, move the left hand looper in or out as necessary. Once the proper clearance has been obtained, re-tighten screw **B**.

3. Move the looper carrier to the left. The right hand looper must have a clearance of between 0.03 and 0.11 mm (.001 and .004"). To adjust, move the right hand looper in or out as necessary. Once the proper clearance has been obtained, re-tighten screw **C**.

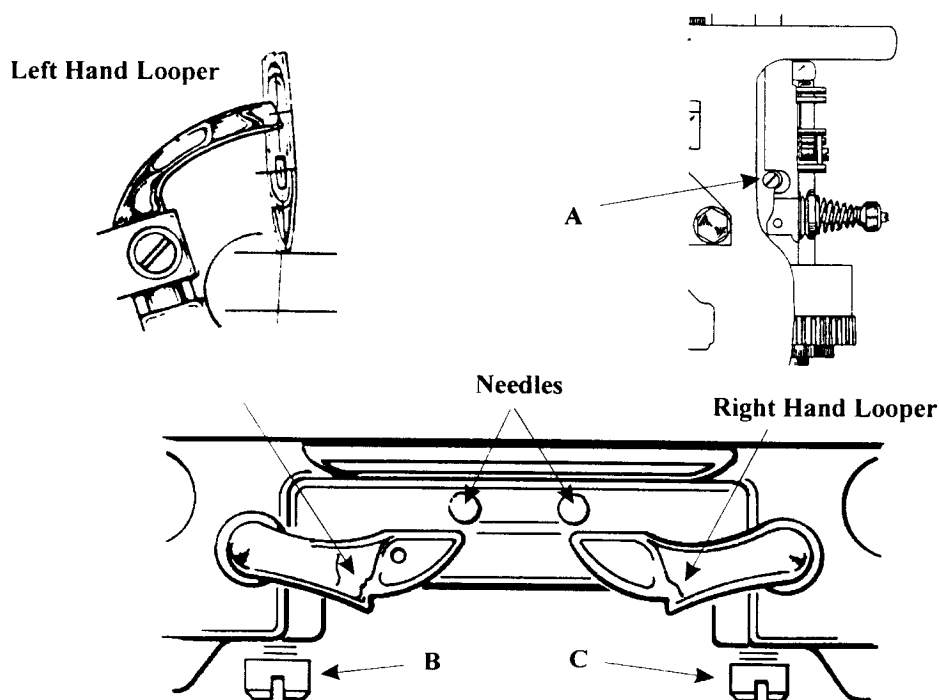

Revised 09/2004

e-mail: service@amfreece.cz; parts@amfreece.cz; website: www.amfreece.com

Phones: +420 582 309 146 (Service), +420 582 309 286 (Spare Parts); Fax: +420 582 360 606

LOOPERS AND SPREADERS

Equalization of Loopers

There are two methods of equalizing the loopers: one method utilizes the 6" scale, and the other method utilizes the timing gauge.

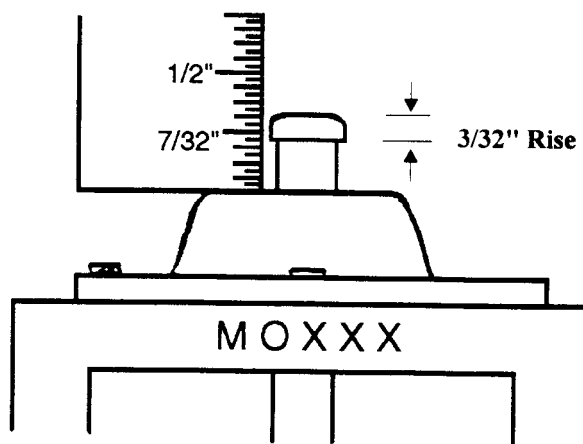
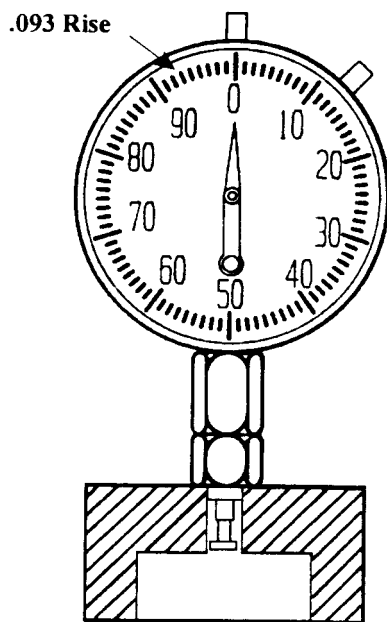

Timing Gauge - 05.0702.0.000

Measure rise using timing gauge, zero out gauge at lowest point of needle bar stroke, measure for rise of .093 on timing gauge.

NOTE: It is not important that the looper reach the center of the needle at this time. It is important that both loopers are equalized after rising .093" or 3/32" on both the needle bar strokes.

1. With the looper carrier still loose, turn the left hand crank until the right hand stop wheel releases.
2. Turn the right hand stop wheel, bringing the needle bar down to its lowest point of the left hand stroke. Continue turning the right hand stop wheel, bringing the needle bar up to a rise of .093" or 3/32", using either the timing gauge or the 6" scale.
3. Move the looper carrier back to the right, and position the point of the left hand looper to the center line of the needle. Re-tighten screw A located on the back side of the race.
4. Continue turning right hand stop wheel, bringing the needle bar to the lowest point of the right hand stroke. Continue turning the right hand stop wheel, bringing the needle bar up to a rise of .093" or 3/32" using either the timing gauge or the 6" scale.

6" Scale

Measure rise using 6" scale, rise is 3/32" from the lowest point of needle bar

Revised 09/2004

e-mail: service@amfreece.cz; parts@amfreece.cz; website: www.amfreece.com

Phones: +420 582 309 146 (Service), +420 582 309 286 (Spare Parts); Fax: +420 582 360 606

LOOPERS AND SPREADERS

5. Loosen screw **A** and move the left hand looper 1/2 the distance noted in step 3. Once the looper has been moved, re-tighten screw **A**. Step 2 through 5 may need to be repeated in order to obtain equalization of the loopers.

6. Moving the left hand looper away from the needle will bring the right hand looper closer to the needle. Moving the left hand looper closer to the needle will move the right hand looper away from the needle.

Left Hand Looper

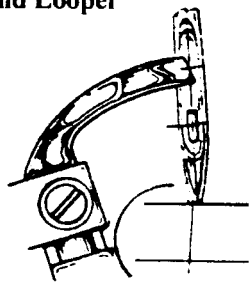

Right Hand Looper

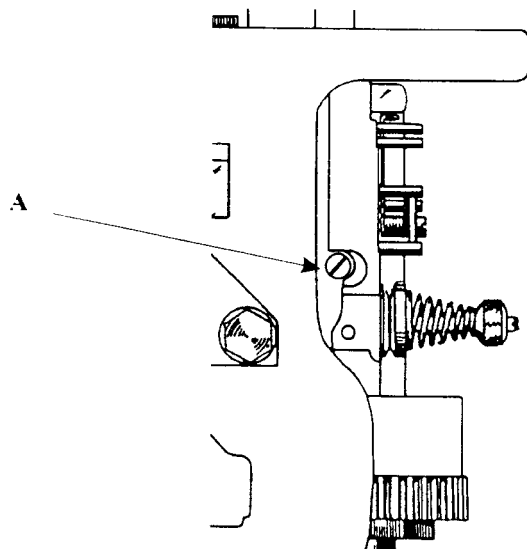
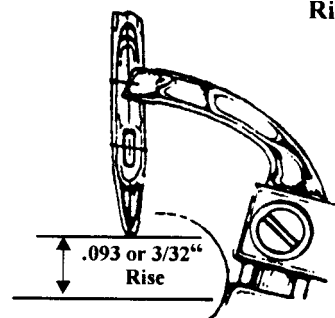

Revised 09/2004

e-mail: service@amfreece.cz; parts@amfreece.cz; website: www.amfreece.com

Phones: +420 582 309 146 (Service), +420 582 309 286 (Spare Parts); Fax: +420 582 360 606

LOOPERS AND SPREADERS

Travel of Loooper to Center of Needle

The loopers must travel to the center part of the needle. To adjust, perform the following steps:

1. Loosen screw **A** and rotate core **B** clockwise or counterclockwise slightly (rotating the core clockwise will move looper toward the needle; rotating the core counterclockwise will move the looper away from the needle). Once the adjustment has been made, re-tighten screw **A**.

NOTE: Make sure screw has been re-tightened before continuing on. If it has not been re-tightened, step 1 **will have** to be repeated.

2. Turn the right hand stop wheel through both needle bar strokes, stopping after the needle bar has risen .093" or 3/32" on both strokes. Check looper to needle to ensure adjustments are correct. If the travel of the loopers is not to the center of the needle, repeat equalizations steps on pages 1-72 and 1-73, and repeat step 1 above.

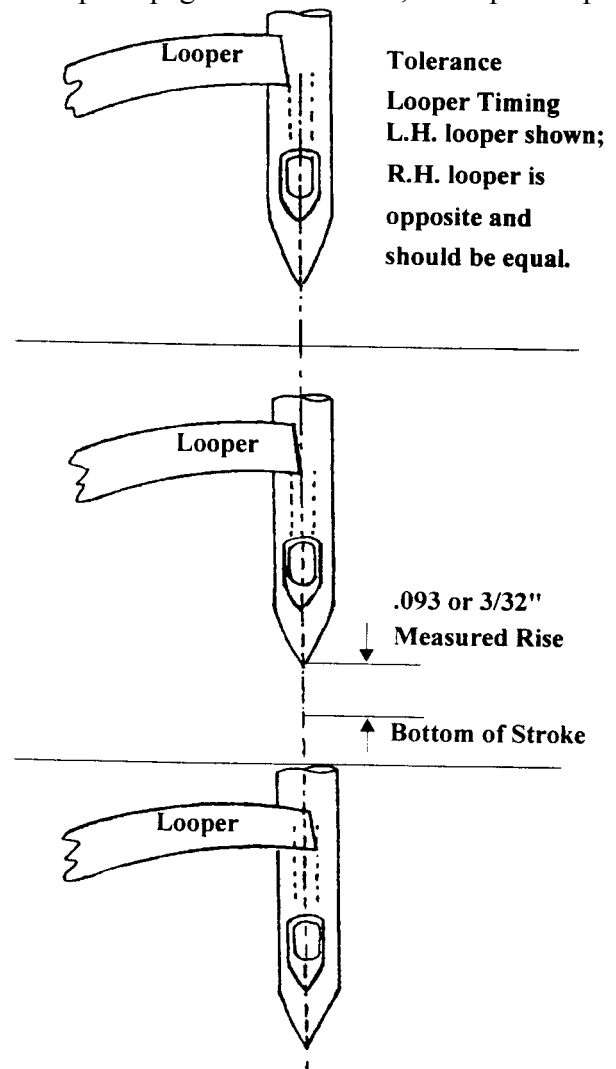
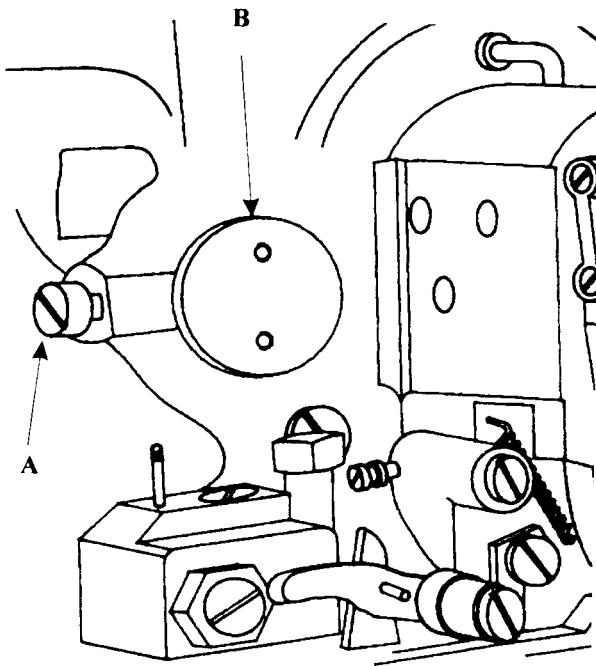

Revised 09/2004

e-mail: service@amfreece.cz; parts@amfreece.cz; website: www.amfreece.com

Phones: +420 582 309 146 (Service), +420 582 309 286 (Spare Parts); Fax: +420 582 360 606

LOOPERS AND SPREADERS

Adjusting Spreader Clearance

1. Install left and right hand spreader and spreader stop.

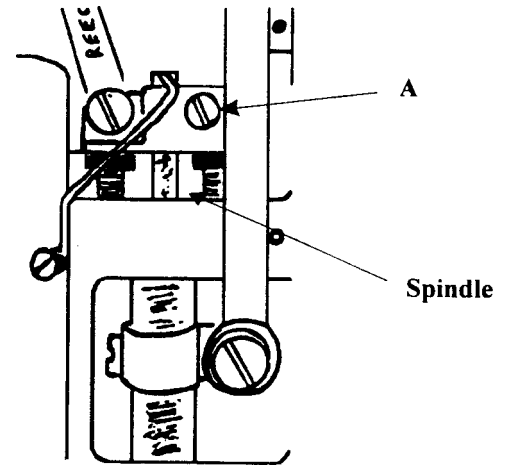

The spreader spindle must be set to approximately 0.79 mm (0.031") above crosshead. To adjust, loosen screw **A** and move the spindle up or down as necessary.

3. Set the left hand spreader stop so that the fork of the left hand spreader straddles to hole in the left hand looper.
4. Set the right spreader stop so that the inner face of the right spreader is flush with the corresponding inner face of the right hand looper.
5. Check the action of both spreaders to ensure that they do not bind against the top surface of the loopers or the spreader stops.
6. Check that spreaders do not move up or down. If there is movement, move the stops down to eliminate the movement.

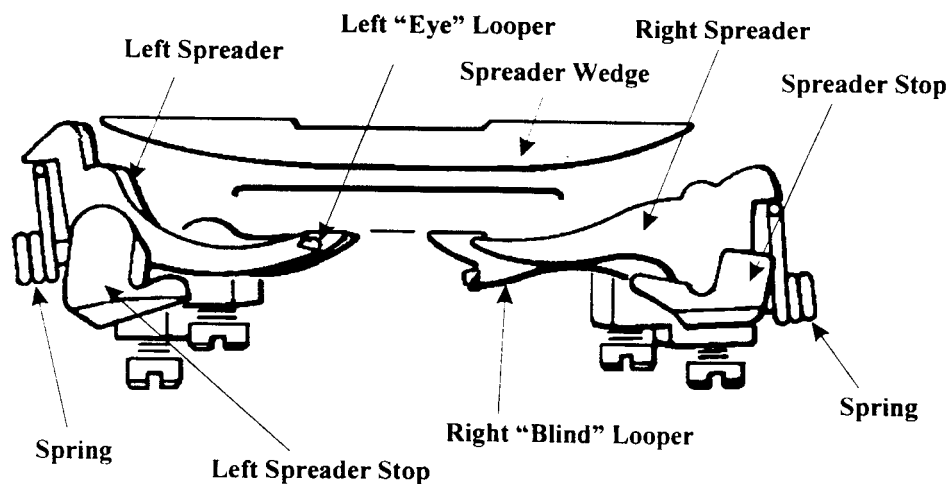

Revised 09/2004

e-mail: service@amfreece.cz; parts@amfreece.cz; website: www.amfreece.com

Phones: +420 582 309 146 (Service), +420 582 309 286 (Spare Parts); Fax: +420 582 360 606

LOOPERS AND SPREADERS

7. As the needle bar moves downward on each stroke and the loopers are moving away from the needle, equal clearance must be obtained between the needle and the spreaders. If clearance is not equal, perform step 8 below.
8. Turn right hand stop wheel until the needle bar goes down on right hand stroke. At this time, the left hand looper is moving away from the needle and the left hand spreader passes the needle. There must be a clearance of between 0.40 and 0.79 mm (.016 and .031") between the spreader and needle. To adjust, loosen nut **B** and move ball stud **C** in or out as necessary. Once the proper clearance has been obtained, re-tighten nut **B**.
9. Continue turning the right hand stop wheel until the needle bar goes down on the left hand stroke. The clearance between the right hand spreader and the needle should be the same as the clearance between the left hand spreader and needle; if the clearance is not the same, repeat step 8 above.
10. Once the correct clearances have been obtained, thread the machine and "sew-off".

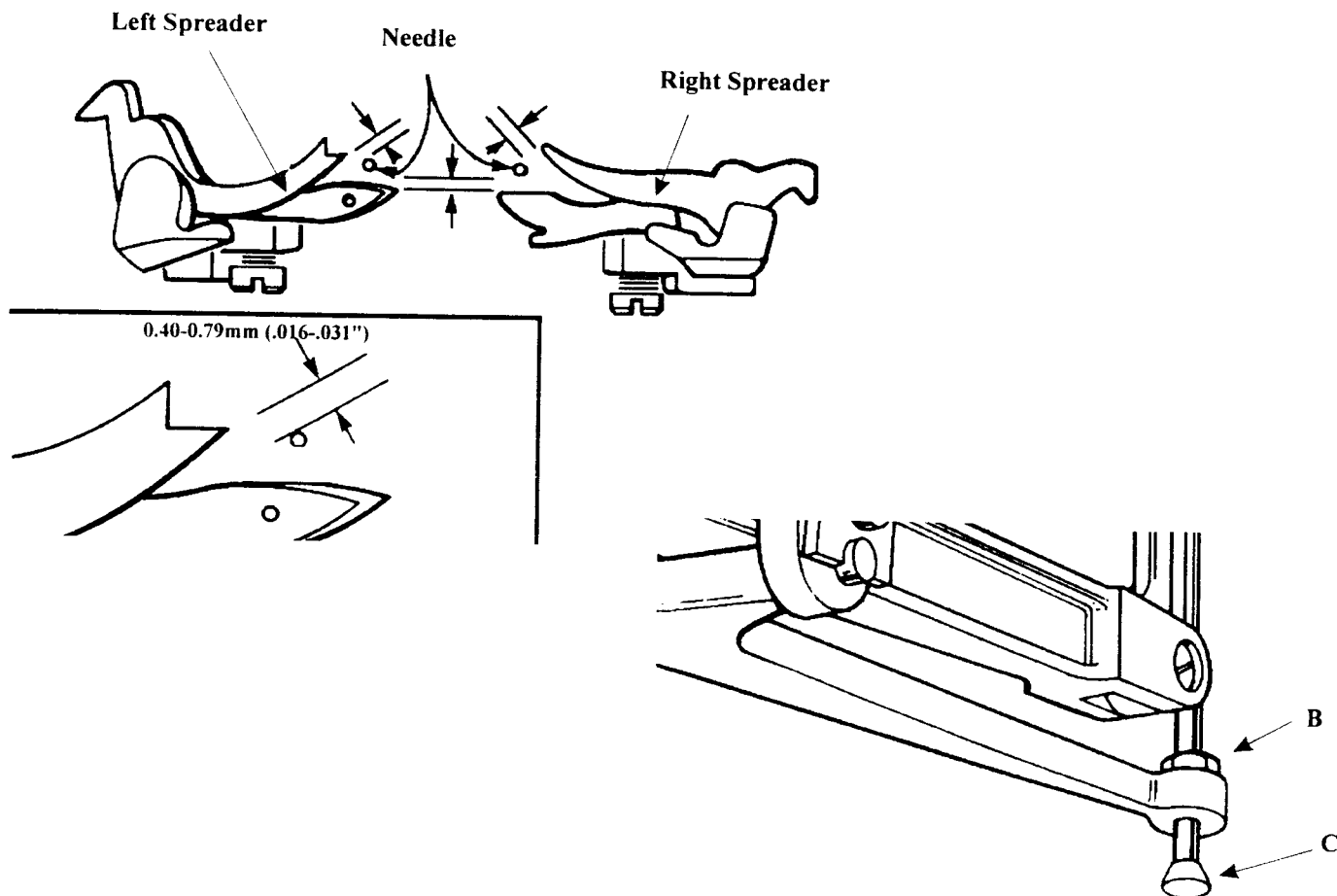

Revised 09/2004

e-mail: service@amfreece.cz; parts@amfreece.cz; website: www.amfreece.com

Phones: +420 582 309 146 (Service), +420 582 309 286 (Spare Parts); Fax: +420 582 360 606

UPPER TENSION THREAD RELEASE

On Cut-After machines, a thread draw-off cam, turning with the upper sector shaft, pivots with the rocking tension assembly forward. During this time, the race is turning to form the eye. When the stitching ends, the race reverses, allowing the rocking tension to fall back. This releases additional slack thread for starting the next buttonhole.

On Cut-Before machines, the cycle ends with the race still facing backward and the tension assembly rocked forward and additional slack starting thread is provided.

To adjust the amount of starting thread after the eye has been completed, stop the machine at any point while stitching the second side of the buttonhole. Loosen screws **A** and turn thread draw-off cam **B** clockwise until rod **C** is at the top of the rise, or counterclockwise until rod **C** is at the low point of the rise (clockwise will increase the amount of starting thread; counterclockwise will decrease the amount of starting thread) as necessary.

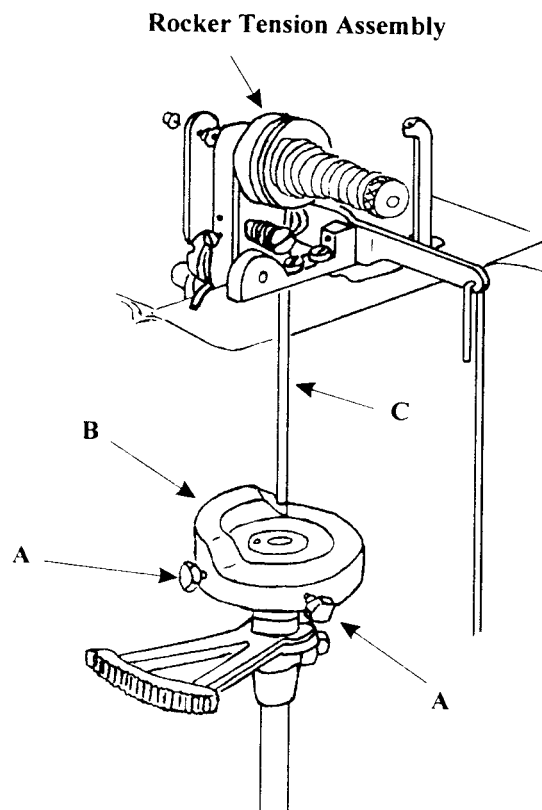

Revised 09/2004

e-mail: service@amfreece.cz; parts@amfreece.cz; website: www.amfreece.com

Phones: +420 582 309 146 (Service), +420 582 309 286 (Spare Parts); Fax: +420 582 360 606

TRIM KNIFE ADJUSTMENT

Adjusting for the relaxed position

The “relaxed” position is when the trim knife assembly is located over the right hand spreader stop and away from the throat plate.

To adjust, loosen nut **A** and turn screw **B** counterclockwise or clockwise (counterclockwise will move the trim knife assembly to the right; clockwise will move the trim knife assembly to the left) as necessary. Once the adjustment has been made, re-tighten nut **A**.

Needle to Trim Knife

Lower the needle bar. The Knife should be set to pass by the needle without touching it. To adjust, loosen screw **C** and move knife in or out as necessary. Once the adjustment has been made, re-tighten screw **C**.

Height of Trim Knife

The knife should be set so it clears the underside of the throat plate, as well as the top of the right hand spreader stop. To adjust, loosen screw **D** and move up or down as necessary. Once the adjustment has been made, re-tighten screw **D**.

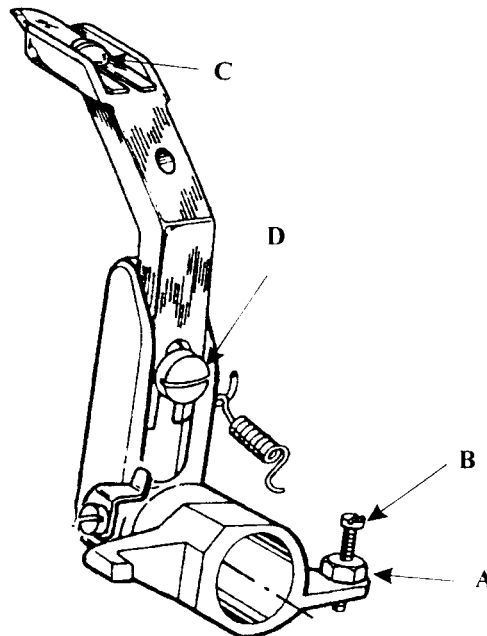

Revised 09/2004

e-mail: service@amfreece.cz; parts@amfreece.cz; website: www.amfreece.com

Phones: +420 582 309 146 (Service), +420 582 309 286 (Spare Parts); Fax: +420 582 360 606

TRIM KNIFE ADJUSTMENT

Upper Thread Trimming for Adjustable Fly

During the machine cycle, when the sewing ends, the machine returns to the home position. However, before reaching the home position, the needle thread trim action trims the front leg of the thread loop. To check for the correct timing of the trimming action, perform the following steps:

1. Turn the left hand crank through a cycle until trip lever has been released. Turn the right hand stop wheel until it locks. Continue turning the left hand crank until the cutting lever starts its downward motion. The lower thread trimming action should start its travel to the right. If the travel does not begin, loosen screws **A**, and slide trip lever **B** forward or backward (forward will delay the trimming action; backward will activate the trimming action earlier) as necessary. Once the adjustment has been made, retighten screws **A**.
2. The travel of the trim knife assembly must be adjusted so the point of the knife does not travel beyond the point of the left hand looper. To adjust, loosen screws **C** (located under actuator **D**) and rotate the actuator **D** forward or backward (forward will increase the amount of travel; backward will decrease the amount of travel) as necessary.
3. A minimum clearance of approximately 0.40 mm (.016") must be maintained between the underside of the cap of actuator **E** and the trim knife assembly. This clearance must exist when the trim knife assembly is located over the right hand spreader stop, and away from the throat plate. To adjust, loosen nut **F** and turn actuator **E** up or down to obtain proper clearance. Once the proper clearance has been obtained, retighten nut **F**.

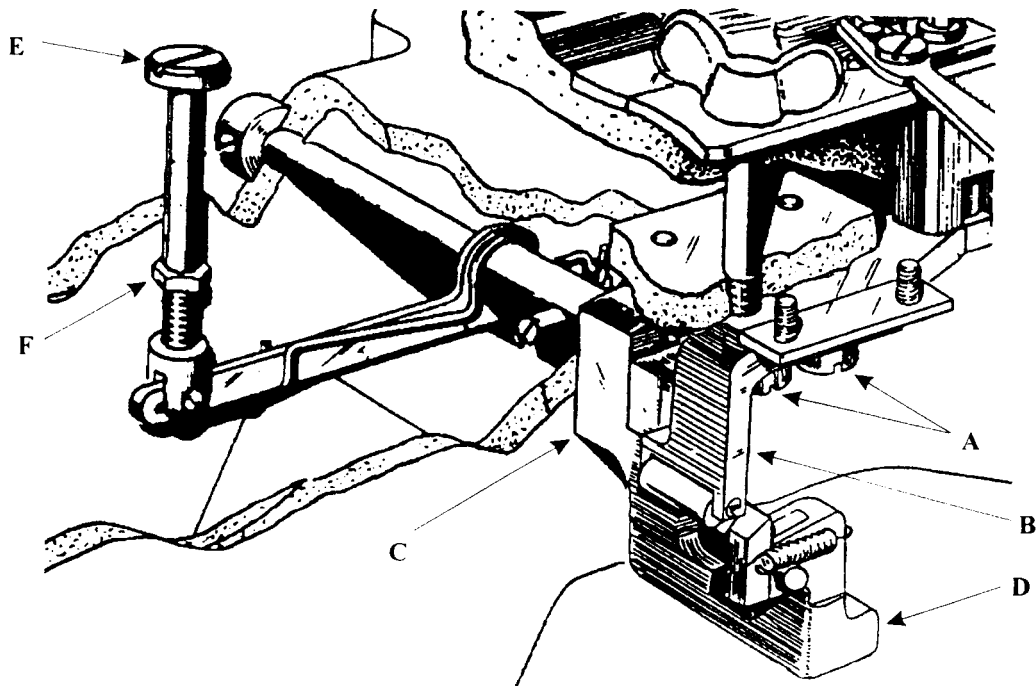

Revised 09/2004

e-mail: service@amfreece.cz; parts@amfreece.cz; website: www.amfreece.com

Phones: +420 582 309 146 (Service), +420 582 309 286 (Spare Parts); Fax: +420 582 360 606

CORD TRIM ADJUSTMENTS

Trim Knife Adjustment

Adjusting for the relaxed position

The “relaxed” position is when the trim knife assembly is located over the right hand spreader stop and away from the throat plate.

To adjust, loosen nut **A** and turn screw **B** counterclockwise or clockwise (counterclockwise will move the trim knife assembly to the right; clockwise will move the trim knife assembly to the left) as necessary. Once the adjustment has been made, re-tighten nut **A**.

Needle to Trim Knife

Lower the needle bar. The knife should be set to pass by the needle as close as possible without touching it. To adjust, loosen screw **C** and move the knife in or out as necessary. Once the adjustment has been made, re-tighten screw **C**.

Height of Trim Knife

The knife should be set so it clears the underside of the throat plate as well as the top of the right hand spreader stop. To adjust, loosen screw **D** and move up or down as necessary. Once the adjustment has been made, re-tighten screw **D**.

Adjusting the Thread Retainer

Thread retainer **E** must rest squarely on the front face of the throat plate. This retains the trimmed thread for the next buttonhole. During the trim knife action, the retainer must be able to travel across the throat plate without binding. To adjust, loosen nut **F** and move screw **G** in or out as necessary. Once the adjustment has been made, re-tighten nut **F**.

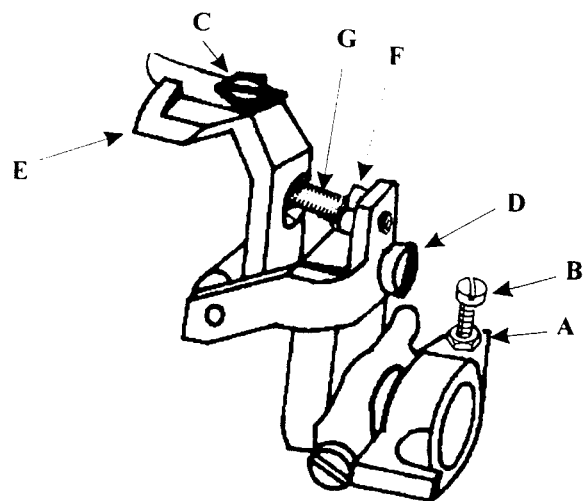

Trim Knife Assembly

Revised 09/2004

e-mail: service@amfreece.cz; parts@amfreece.cz; website: www.amfreece.com

Phones: +420 582 309 146 (Service), +420 582 309 286 (Spare Parts); Fax: +420 582 360 606

CORD TRIM ADJUSTMENTS

Upper Thread Trimming

During the machine cycle, when the sewing ends, the machine returns to the home position. However, before returning home, the needle thread trim action trims the front leg of the thread loop. To check for the correct timing of the trimming action, perform the following steps:

1. Turn the left hand crank through a cycle until the trip lever has been released. Turn the right hand stop wheel until it locks. Continue turning the left hand crank until the cutting lever starts its downward motion. The lower thread draw-off should start moving to the left with the race facing the rear of the machine. The top thread trimming action should start its travel to the right. If the travel does not begin, turn the left hand crank until wedge **H**, located on cam **I**, can be seen through the open area of the cam case, in front of the stitch feed assembly on the right hand side of the machine. Once the wedge can be seen, loosen screws **J** and move wedge either forward or backward (forward will make the trimming action happen sooner; backward will make the trimming action happen later) as necessary. Once the adjustment has been made, re-tighten screws **J**.

2. As the machine travels through its cycle, wedge **H** lifts lever **K** which causes the downward movement of actuator **L**. This downward movement determines the amount of travel of trim knife assembly. The travel must not be adjusted so the point of the knife does not travel beyond the point of the left hand looper. A minimum clearance of approximately 0.40 mm (.016") must be maintained between the underside of the cap of the actuator and the trim knife assembly when the trim knife assembly is positioned over the right hand spreader stop and away from the throat plate. To adjust, loosen nut **M** and turn actuator **L** counterclockwise or clockwise (counterclockwise will decrease the amount of travel; clockwise will increase the amount of travel). Once the adjustment has been made, re-tighten nut **M**.

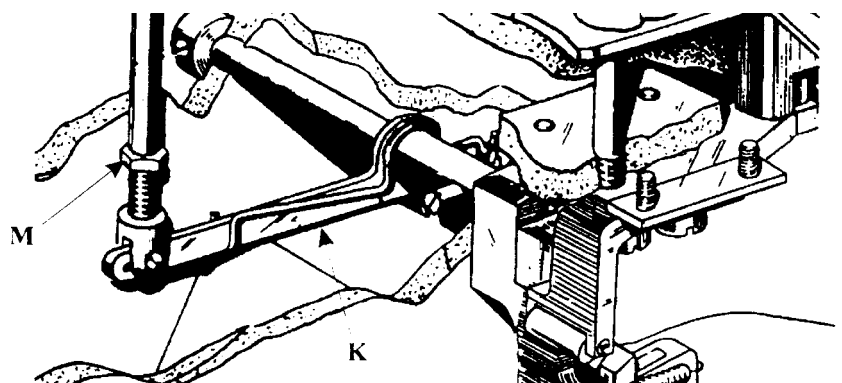
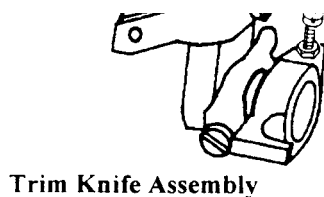
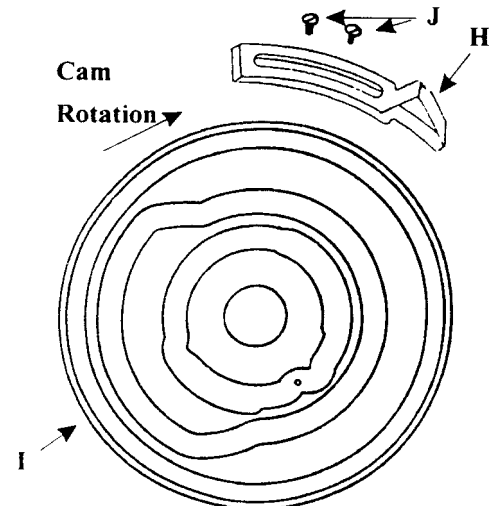

Revised 09/2004

e-mail: service@amfreece.cz; parts@amfreece.cz; website: www.amfreece.com

Phones: +420 582 309 146 (Service), +420 582 309 286 (Spare Parts); Fax: +420 582 360 606

CORD TRIM ADJUSTMENTS

Upper Thread Trimming for - 170 Short Travel Cord Trim

During the machine cycle, the sewing ends and the machine returns to the home position. However, before returning home, the needle thread trim action trims the front leg of the thread loop. To check for the correct timing of the trimming action, perform the following steps:

1. Turn left hand crank until the trip lever has been released and the right hand stitch wheel locks. Continue turning the left hand crank until the cutting lever starts its downward motion. The lower thread draw-off should start moving to the left and the race should be facing the rear of the machine. The top thread trimming action should start its travel. The race should still be facing the rear of the machine, and the travel should begin to the right. If the travel does not begin, loosen screws **N**, and slide trip lever **O** forward or backward (forward will delay the trimming action: backward will activate the trimming action earlier) as necessary. Once the adjustment has been made, re-tighten screws **N**.

2. The travel of the trim knife assembly must not go beyond the outside left edge of the trim knife assembly. To adjust, loosen screws **P** (located under actuator **Q**), and rotate actuator **Q** forward or backward (forward will increase the amount of travel; backward will decrease the amount of travel) as necessary.

1. A minimum clearance of approximately 0.40 mm (.016") must be maintained between the underside of the cap of actuator **L** and the trim clearance must exist when trim knife assembly is located over the right hand spreader stop and away from the throat plate area. To adjust, loosen nut **M** and turn actuator **L** up or down to obtain proper clearance. Once the proper clearance has been obtained, re-tighten nut **M**.

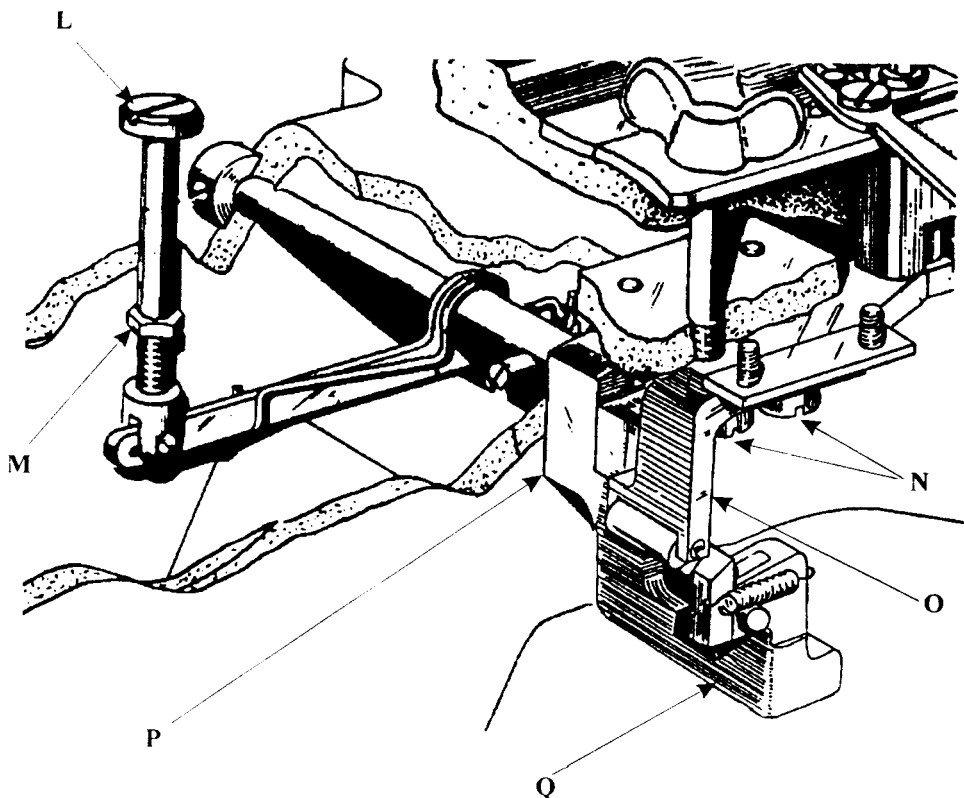

Revised 09/2004

e-mail: service@amfreece.cz; parts@amfreece.cz; website: www.amfreece.com

Phones: +420 582 309 146 (Service), +420 582 309 286 (Spare Parts); Fax: +420 582 360 606

CORD TRIM ADJUSTMENTS

Lower Thread Draw-off

The lower thread draw-off is used to supply enough lower thread into the buttonhole as it is forming the stitch. This allows the thread to be trimmed and still have enough thread retained for the next buttonhole. To adjust, perform the following step:

1. Actuator assembly **B** may need to be adjusted for correct tension release. The correct adjustment is when actuator assembly **B** is resting against the race, and the lower tension disc is closed. When the actuator is moved approximately 1/8" away from the race, the lower tension disc is opened. To adjust, loosen screw **C** and move block **D** left or right as necessary.
2. The travel of the actuator assembly **B** must be correct. To adjust, loosen nut **A** and move stud up or down as required. The standard setting for travel will have edges **E** and **F** parallel to each other once actuator assembly **B** has completed its full travel. Once the correct travel has been obtained, re-tighten nut **A**.

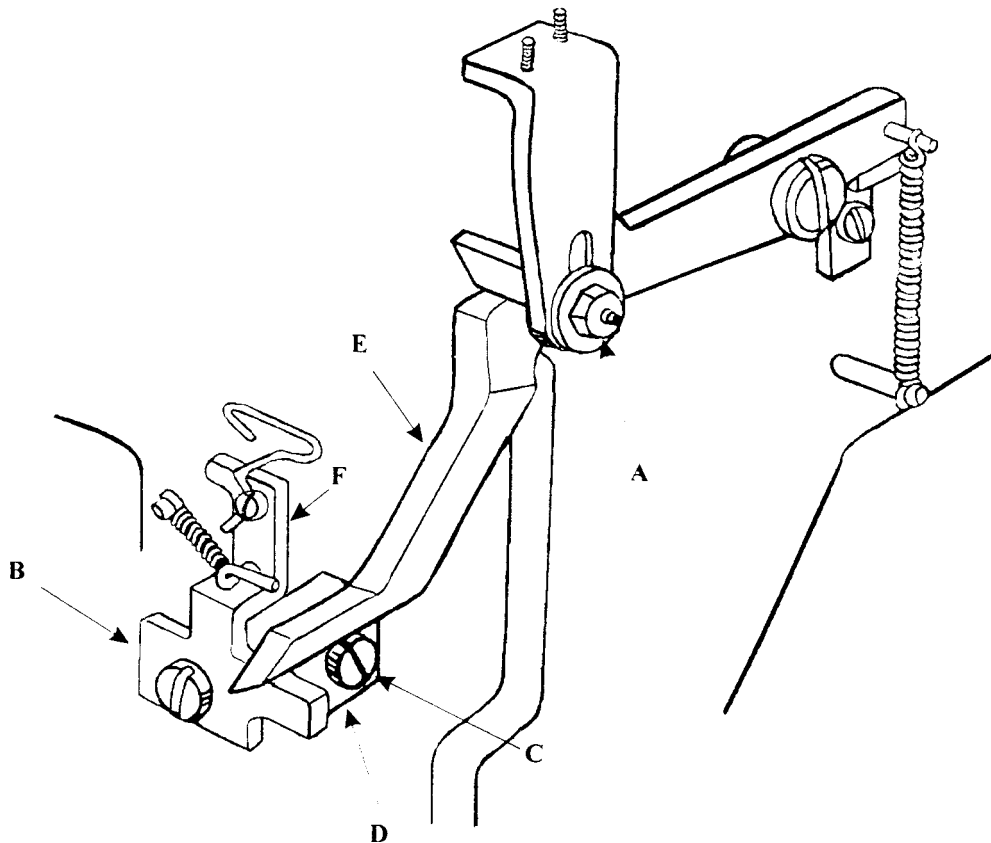

Revised 09/2004

e-mail: service@amfreece.cz; parts@amfreece.cz; website: www.amfreece.com

Phones: +420 582 309 146 (Service), +420 582 309 286 (Spare Parts); Fax: +420 582 360 606

CORD TRIM ADJUSTMENTS

Adjustment of the Clamp Hold-Down Fingers

The fingers hold the garment in place during the shear trimming action. Without the finger, the garment would be permitted to move, causing failure to trim the lower threads, in addition to damaging the garment.

The fingers become engaged after the clamp arms are released and as the bedplate is moving to the rear. At this time, the fingers have moved down, holding the garment in place during the shearing action. Pressure of the fingers and the height of the fingers are two areas in which adjustments need to be made. Both adjustments require that the ball end of the screw **B** must be able to pass over wedge **C** without binding or damaging parts.

1. To adjust the pressure of the hold down fingers, loosen nut **A** and move screw **B** up or down (up will decrease the pressure; down will increase the pressure) as necessary.
2. To adjust the height of fingers, turn the left hand crank until the machine is in the home position. Loosen nut **D** and turn screw **E** in or out (in will decrease height; out will increase the height) as necessary.

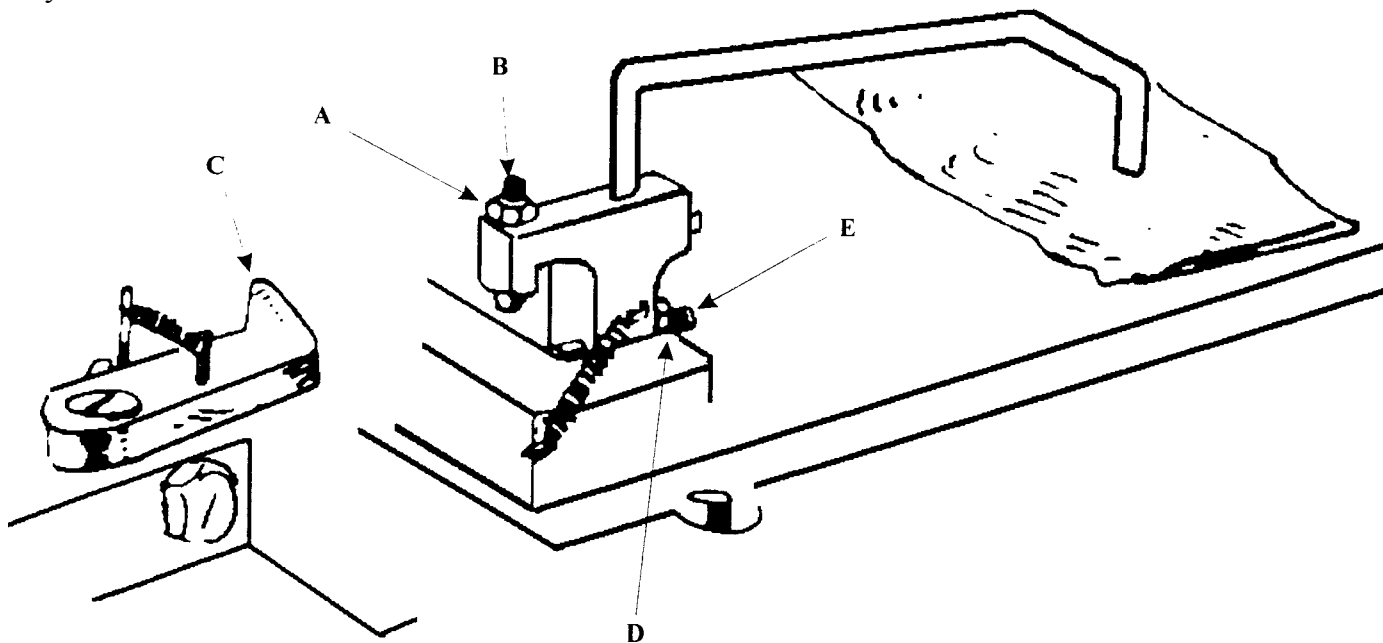

Revised 09/2004

e-mail: service@amfreece.cz; parts@amfreece.cz; website: www.amfreece.com

Phones: +420 582 309 146 (Service), +420 582 309 286 (Spare Parts); Fax: +420 582 360 606

CORD TRIM ADJUSTMENTS

Adjustment of the Shear Sets

The Cord Trim shears are designed like a pair of scissors. The edge must cross over each other. However, too much cross-over will cause the machine to malfunction, thus damaging key parts. For this reason, it is **imperative** that the correct adjustment be maintained.

Installation of shears to clamp plates

1. Holding the clamp plate, insert spring **A** into the circle cut-out area of the clamp plate.
2. Place lower shear **B** over the spring. Place upper shear **C** on top of the lower. Insert shoulder screw **D** in the circle cut-out area of the clamp plate through the upper and lower shears and spring. Turn the upper and lower shears to ensure shoulder screw has gone through all the parts without binding.

NOTE: Add a few drops of oil during step 2.

3. Tighten screw **D** and attach springs **E** to the outside edges of the upper and lower shears.
4. Turn the clamp plate over and install nut **F** onto screw **D**. Using your fingers, turn nut as far as it will turn, without tightening.
5. Turn clamp plate top up, facing forward, using your thumb to move actuator **G** to the left to close the shears.
6. If the shears are locked into position, turn screw **D** just enough to allow shears to open. Once this has occurred, turn the screw counterclockwise approximately 1/4 of a turn.
7. Turn plate over; holding screw **D** in place not allowing it to turn, tighten nut **F**. Re-check shears to ensure that they cross over each other, and return to the open position. This is done by repeating step 5.
8. Install the cover plate. Re-check shears once again to ensure they cross over each other, and return to the open position. If they do not cross over and return to the open position, repeat step 6.

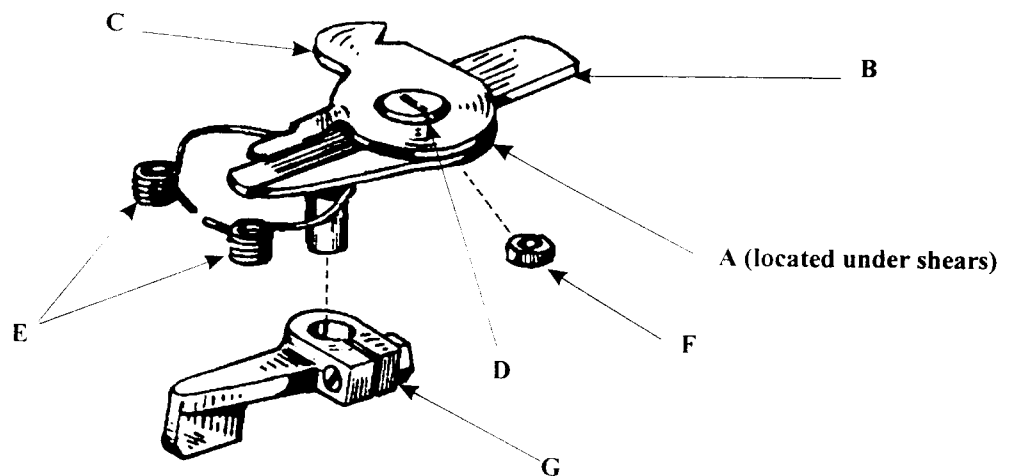

Revised 09/2004

e-mail: service@amfreece.cz; parts@amfreece.cz; website: www.amfreece.com

Phones: +420 582 309 146 (Service), +420 582 309 286 (Spare Parts); Fax: +420 582 360 606

CORD TRIM ADJUSTMENTS

Shear Cross-Over

Knife actuator **G** is adjusted to run parallel to the edge of the clamp plate. The shears are activated when the race starts to turn back to the home position. As the race turns the paddle, located on the rear of the race, engages the knife actuator which causes the shears to cross-over. Having the actuator parallel brings the cutting edges together without causing a bind in the machine. If the shears are forced to cross-over more than required (edges crossing over until they meet at the point), the machine will bind and damage key parts, including the main cam. Below is an example of the shears when they are in the correct parallel position.

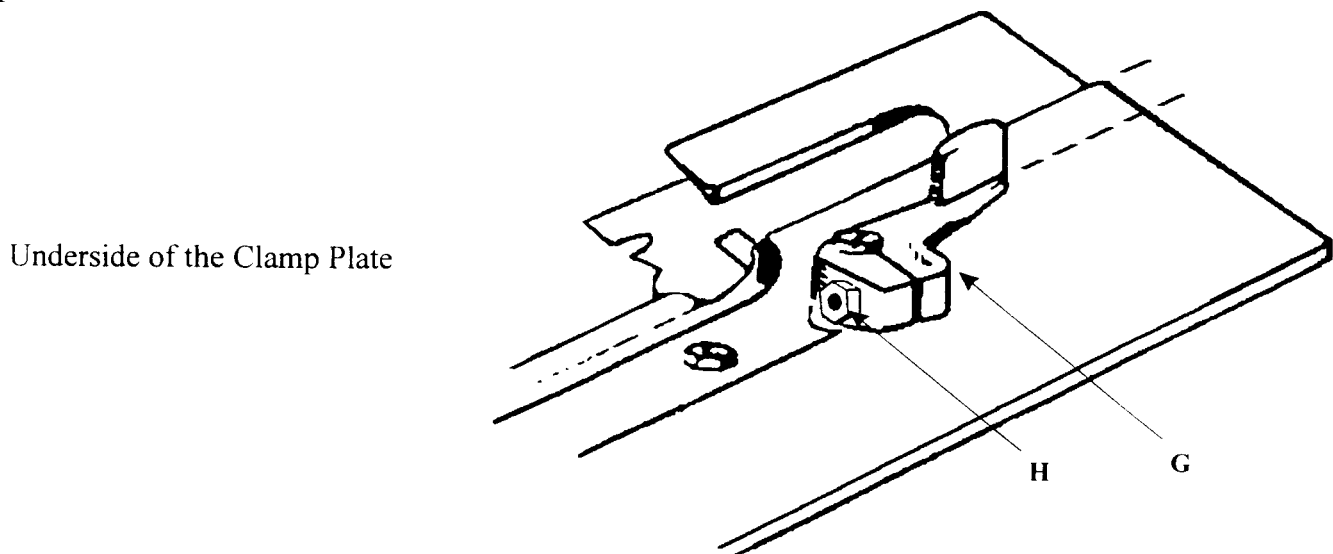

To adjust, loosen nut **H** and rotate actuator to correct position. Once the correct position has been obtained, re-tighten nut **H**.

NOTE: The correct buttonhole lengths must be maintained. Long sewing of the buttonhole will cause the needle to strike the shears, causing damage to both the needle bar and shears.

CORD TRIM ADJUSTMENTS

Shears Cross-Over for - 170 Short Travel Cord Trim

The short travel cord trim may require the adjustment of actuator **G**. The adjust would be approximately 15 degree off the parallel adjustment, as described for standard cord trim on page 1-86. To adjust, loosen nut **H** and rotate actuator to correct position. Once the proper position has been obtained, re-tighten nut **H**.

This change may be required when sewing the short buttonhole (1/2"). The shear action must be delayed to allow the clamp arms enough time to disengage before the shearing action begins.

NOTE: Turn the left hand crank through cycle to ensure that the shears do not strike the clamp feet. **DO THIS BEFORE CYCLING THE MACHINE UNDER POWER.**

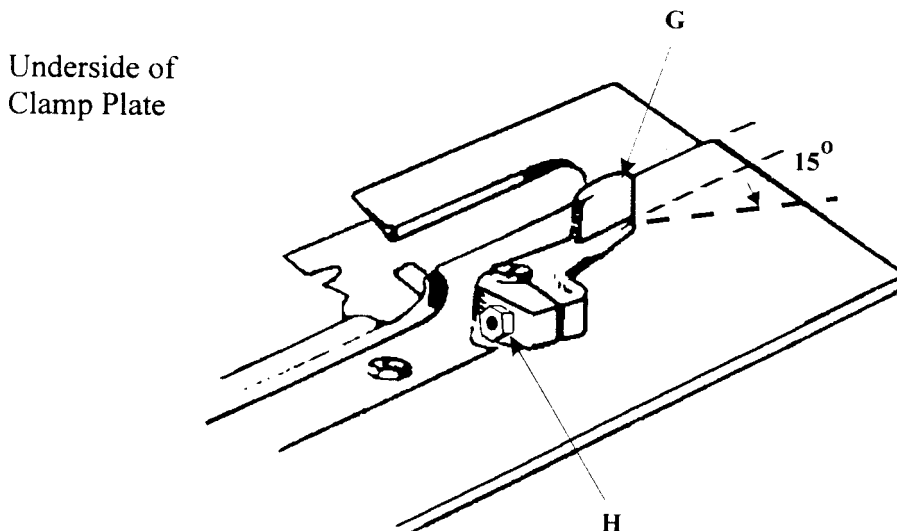

Revised 09/2004

e-mail: service@amfreece.cz; parts@amfreece.cz; website: www.amfreece.com

Phones: +420 582 309 146 (Service), +420 582 309 286 (Spare Parts); Fax: +420 582 360 606

CORD TRIM ADJUSTMENTS

Gimp Pull Back

A gimp pull back is provided to ensure that there is enough gimp to start the next buttonhole. Spring **A** acts as a clamp and also adds tension on gimp. Before performing this adjustment, remove gimp pull back assembly **B** from the machine by pressing inward on floating pin **C**, which is located on the race. Loosen screw **D** and move the spring up or down until its top edge is slightly under the top of the gimp hole. The gimp should slide through the hole freely, but not be able to be pulled back through the hole. Once the gimp can slide through the hole freely, re-tighten screw **D**.

If tension is incorrect, adjust by slightly bending spring **A** in or out (in creates more tension; out creates less tension) as necessary.

Weight **E** pulls gimp back through the hole in throat plate at the end of the cycle. If the weight is adjusted forward, it increases the amount of starting gimp; if the weight is adjusted so it sits back, it decreases the amount of starting gimp. To adjust the length of the starting gimp, loosen screw **F** and move stop **G** up or down to obtain the desired amount of starting gimp.

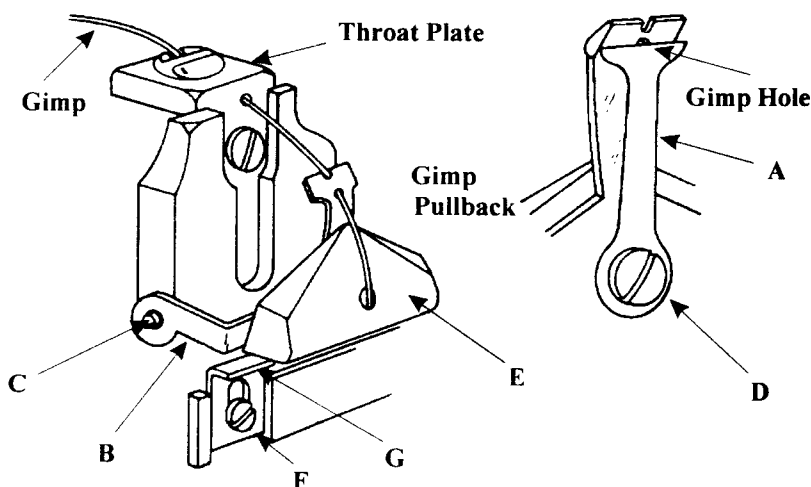

Stitch Increase / Decrease Wedge

Wedge **A** is used to add or remove stitches to / from the eye of the buttonhole. To adjust, turn the left hand crank until roll **C** is located on the ramp of the wedge. Loosen screw **B** and move the wedge forward or backward (moving the wedge forward increases the number of stitches backward decreases the number of stitches) as necessary.

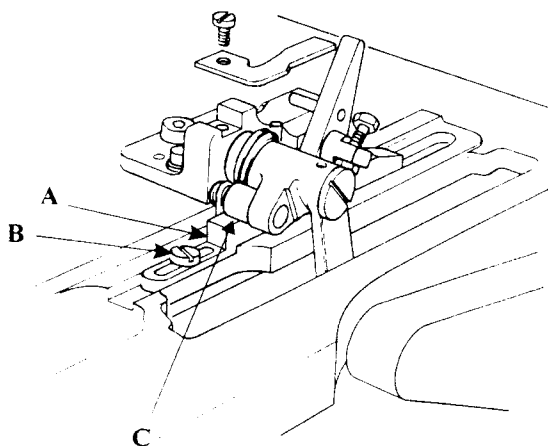

Revised 09/2004

e-mail: service@amfreece.cz; parts@amfreece.cz; website: www.amfreece.com

Phones: +420 582 309 146 (Service), +420 582 309 286 (Spare Parts); Fax: +420 582 360 606

CORD TRIM ADJUSTMENTS

Top Thread Pick-Up

The thread pick-up hook is activated by the downward movement of the cutting lever. Turn the left hand crank until the machine has completed a cycle. Observe the thread pick-up hook as it makes its downward plunge. The amount of travel required is just enough to reach the point of the needle, just passing beyond the needle thread. To adjust, loosen pivot screw **A**, and move swing plate **B** up or down (up allows the pick-up hook more of a reach; down allows the pick-up hook less of a reach) as necessary. Once the adjustment has been made, re-tighten screw **A**.

The thread pick up hook should line up with the needle's center line. To adjust, bend the thread pick-up hook left or right as necessary. Use a pair of long needle nose pliers.

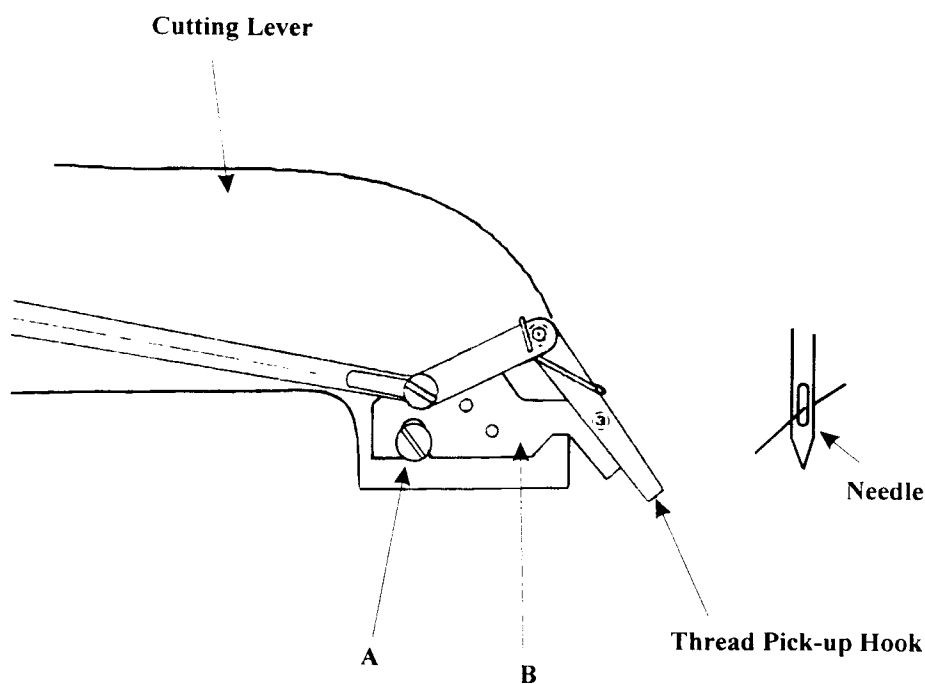

Revised 09/2004

e-mail: service@amfreece.cz; parts@amfreece.cz; website: www.amfreece.com

Phones: +420 582 309 146 (Service), +420 582 309 286 (Spare Parts); Fax: +420 582 360 606

SELECTING CUT BEFORE (CB) OR CUT AFTER (CA)

Selecting Cut Before (CB) or Cut After (CA)

Change from CB to CA

1. Move the bedplate to its home position.
2. Move the selector lever **A**, located on the left to the rear of the machine head, to the CA position.
3. Loosen bolt **B** and slide clamping arm **C** to the rear for the CA position. Once the clamping arm has been moved backward, re-tighten bolt **B**.

Change from CA to CB

1. Move the bedplate to its home position.
2. Move selector lever **A**, located on the left to the rear of the machine head, to the CB position.
3. Loosen bolt **B** and slide clamping arm **C** forward for the CB position. Once the clamping arm has been moved forward, re-tighten bolt **B**.

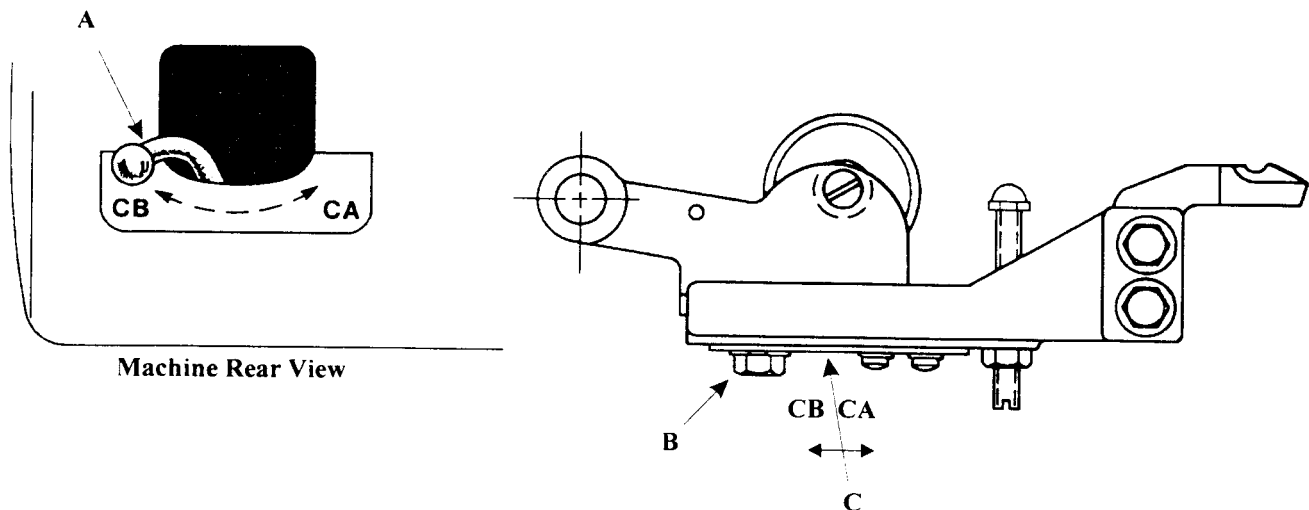

Revised 09/2004

e-mail: service@amfreece.cz; parts@amfreece.cz; website: www.amfreece.com

Phones: +420 582 309 146 (Service), +420 582 309 286 (Spare Parts); Fax: +420 582 360 606

PREVENTIVE MAINTENANCE

It is necessary to establish a good preventive maintenance program and adhere to it. It is necessary that the oil is checked and replenished when needed, and the machine be freed of any pieces of material and loose thread on a daily basis. To do this, it is recommended that you have the following items on hand for the everyday upkeep and cleaning of your machine.

oil
vacuum cleaner / paint brush / parts brush

NOTE: DO NOT use an air blower in place of a vacuum. The air blower could blow particles into the cam, thus damaging it.

Below is a Periodic Maintenance Checklist which lists the types of preventive maintenance to be done, and how often they need to be done”

<u>DAILY</u>	Oil machine
	Remove lint from loopers and spreaders
<u>WEEKLY</u>	Check belt tension
	Inspect and replace (if necessary) knife and block
<u>MONTHLY</u>	Check Stop Motion
	Check for loose hardware, replace parts as necessary
	Check throat plate for wear, replace if necessary

Revised 09/2004

e-mail: service@amfreece.cz; parts@amfreece.cz; website: www.amfreece.com

Phones: +420 582 309 146 (Service), +420 582 309 286 (Spare Parts); Fax: +420 582 360 606

1-91

RECOMMENDED SPARED PARTS

It is recommended that the following spare parts and quantities be kept in stock. These parts are sold individually.

<u>Part Number</u>	<u>Description</u>	<u>Qty</u>
01.2193.0.000	Needle Screw	1
01.2001.0.000	Looper and Spreader Screw	2
01.2056.0.000	Throat Plate Screw	1
10.1030.0.017	Screw	1
01.2102.0.000	Screw	1
01.2667.0.000	Screw	1
10.1029.1.000	Tension Disc	2
14.4009.1.000*	Forked Spreader	1
14.4005.0.000*	Eye Looper	1
14.4008.1.000*	Right Spreader	1
14.4004.0.000*	Blind Looper	1
14.4009.1.350**	Lg. Diameter Thread Eye Looper	1
14.4005.0.350**	Single Thread Round Eye Looper	1
01.5620.0.000	Left Spreader Spring	2
01.5619.0.000	Right Spreader Spring	2
01.5167.0.000	Spring	1
01.5433.0.000	Spring	1
14.1092.1.000	Brake Shoe	1
01.5606.0.000	Stop Motion Spring	1
14.1197.0.000	Trimming Knife	1
10.3553.0.003**	3/32 Round Eye Knife	1
10.3553.0.004**	1/8 Round Eye Knife	1
17.0064.5.XXX***	Eye Knife	1
10.4012.0.004**	Adjustable Fly CB/CA Throat Plate	1
10.4012.0.001**	Adjustable Fly Throat Plate	1
14.4012.0.015**	Cord Trim Throat Plate	1
10.4012.0.019**	Round Eye Throat Plate	1

* The parts can be sold as a kit. The kit number is 03.5250.0.000.

** These parts are only utilized by certain models machines. Only keep on hand if you are using that model machine which requires that style part.

*** The last three numbers of the part number will vary depending upon the type of knife used. See page 1-96 for ordering instruction.

Revised 09/2004

e-mail: service@amfreece.cz; parts@amfreece.cz; website: www.amfreece.com

Phones: +420 582 309 146 (Service), +420 582 309 286 (Spare Parts); Fax: +420 582 360 606

NEEDLES

Below is a chart listing needles and their description available for the AMF Reece eyelet machines. They are of superior struck groove construction, and chrome plated. They vary in size and type as listed below. These needles can be purchased by the box (100/box) through the Part Department.

<u>TYPE</u>	<u>APPLICATION</u>	<u>PART NUMBER</u>
Round Point Long Shank	Applicable to the majority of woven fabrics, knits and other materials of similar consistency. The long shank needles have added stiffness in the blade which permits	02.0500.1.100 Very Fine
Round Point	the use of one size smaller needle than would be normally required. Long shank needles can not be used on heavy material that would be penetrated by the tapered portion of the needle shank.	02.0501.0.111 Medium 02.0501.3.112 Heavy 02.0501.3.113 Very Heavy
Round Point Double Groove	The double groove needle should be used only when the looper points are set close to the needle blade. This needle is used on materials having a tendency to trap the thread in its descent into the work which affects the thread take-up or causes the thread to break at the needle's eye.	02.0503.3.111 Medium 02.0503.0.112 Heavy 02.0503.3.113 Very Heavy
Extra Long Point Ball Eye	Applicable to fabrics which offer high resistance to needle penetration. Also recommended in cases where fast trimming of the loopers is necessary. This needle differs from the 501 type needle only in length from the eye point.	02.0504.3.111 Medium 02.0504.0.112 Heavy 02.0504.3.113 Very Heavy 02.0504.0.114 Heavy Denim
Ball Point Long Shank	Applicable to synthetic fabrics, particularly of the tightly woven or tightly knitted where the fibers of the material are subject to damage by conventional sharp pointed needles.	02.0505.1.100 Very Fine 02.0505.3.110 Fine
Ball Point Rocked Point Ball Eye	Applicable to leather and similar materials where conventional sharp pointed needles tend to leave excessive punctures. The split made by rocked point needles in leather will tend to close up after penetration. This needle permits a higher stitch density than is possible in leather with a round point needle.	02.0505.0.111 Medium 02.0506.0.111 Medium 02.0506.3.112 Heavy 02.0506.3.113 Very Heavy
Spear Point	Applicable to fabrics containing a high percentage of starch or similar substances which tend to cause needle heating or resistance to proper pulling up of the stitches.	02.0508.0.110 Fine 02.0508.0.111 Medium 02.0508.0.112 Heavy 02.0508.0.113 Very Heavy

Revised 09/2004

e-mail: service@amfreece.cz; parts@amfreece.cz; website: www.amfreece.com

Phones: +420 582 309 146 (Service), +420 582 309 286 (Spare Parts); Fax: +420 582 360 606

KNIVES AND CUTTING STEELS

The knives and cutting steels are stamped with the last four digits of this part number. The cutting steels are also stamped with its size. To reorder original knives or cutting steels, give the first six digits of the part number, plus the last four digits stamped on the original part. The following is an examples of eye styles, knives and cutting steels.

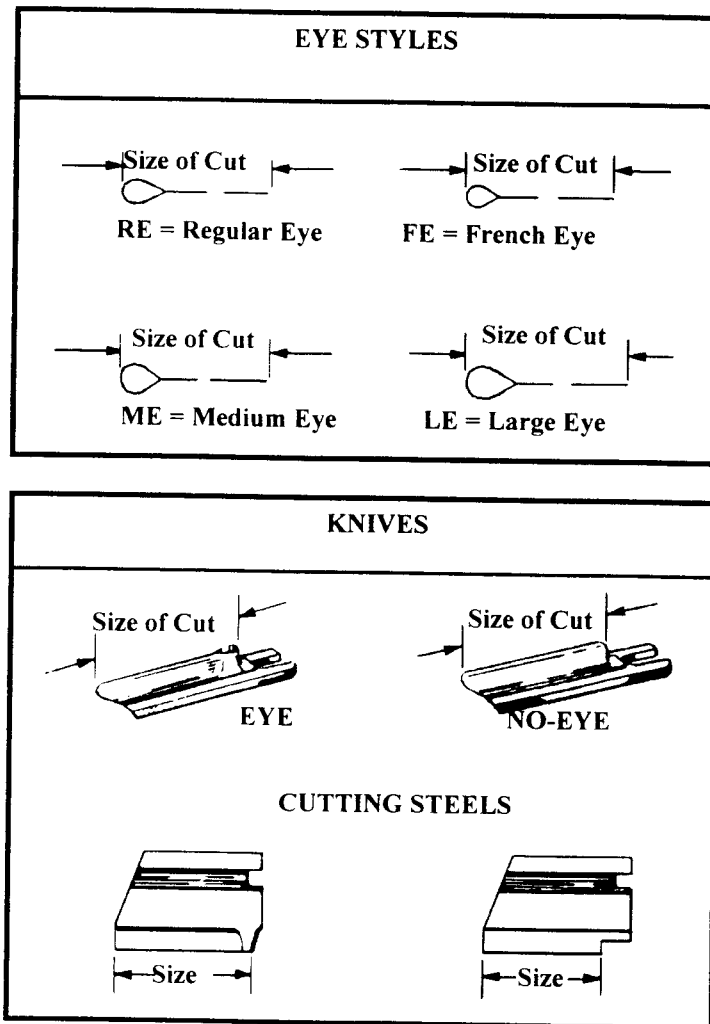

Revised 09/2004

e-mail: service@amfreece.cz; parts@amfreece.cz; website: www.amfreece.com

Phones: +420 582 309 146 (Service), +420 582 309 286 (Spare Parts); Fax: +420 582 360 606

TROUBLESHOOTING

Reversing Direction of the Main Cam

In the event that something becomes lodged between the main cam and the roller, the rotation of the main cam can be reversed so the object lodged can be removed. This can be done without having to disassemble the machine. The following procedure may be performed on both the 104-100 and 104-200 machines.

1. Remove the stitch feed located in the lower right corner of the machine by removing nut and washer **A** and nut **B**. Remove arm **C**. Remove link **D** by removing stud **E** located behind cam follower **F**. At this point, the slide stud located on the lower end of link **D** can be removed from the stitch feed housing.
2. Remove stud **G** located on the lower end of link **H** by pushing link forward, clearing stitch feed assembly. Slide the stud out.
3. Remove snap ring **I** which holds the stitch feed housing onto the end of the shaft. Push link **H** forward, and slide the housing off the shaft.

NOTE: DO NOT lose washer, located behind the snap ring, when sliding the housing off the shaft.

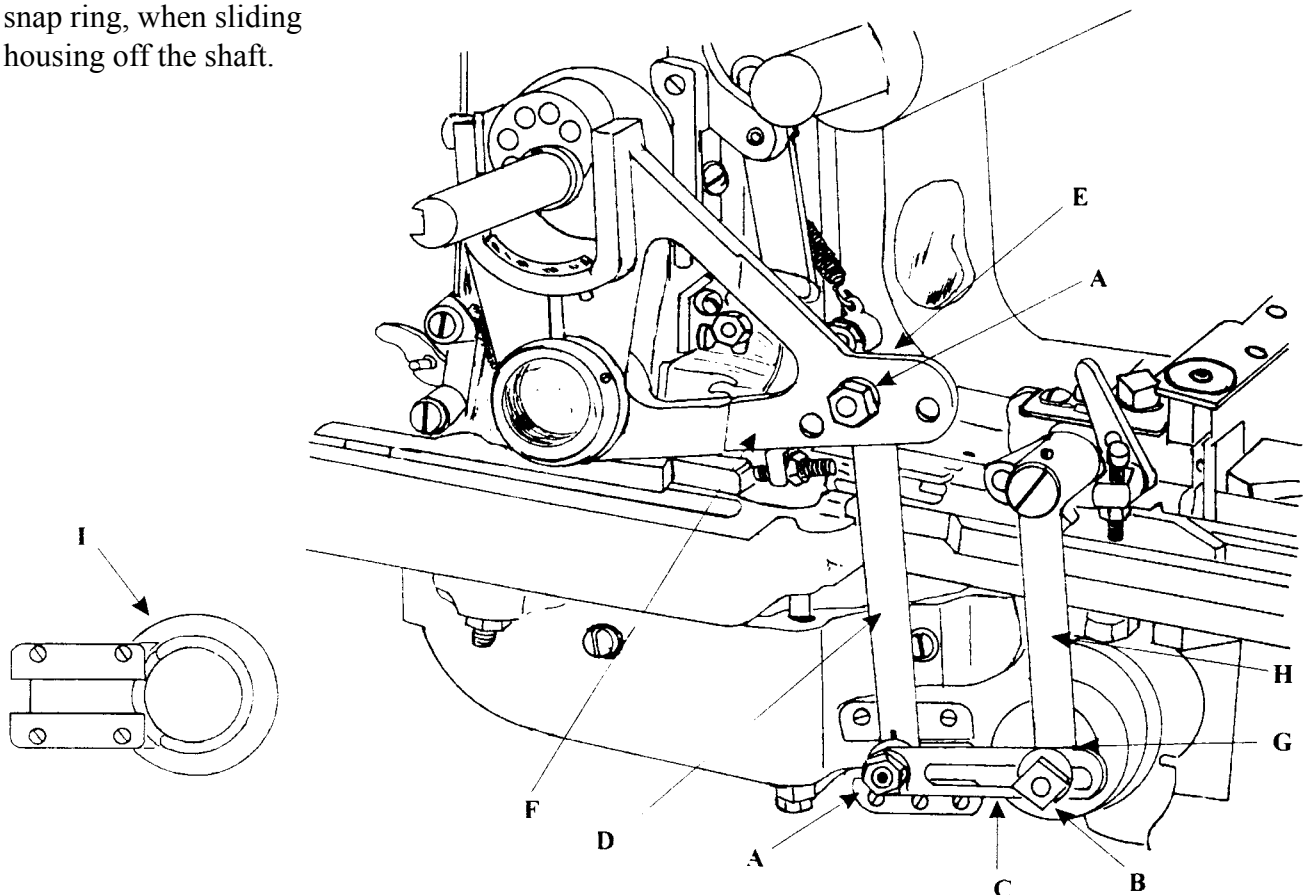

Revised 09/2004

e-mail: service@amfreece.cz; parts@amfreece.cz; website: www.amfreece.com

Phones: +420 582 309 146 (Service), +420 582 309 286 (Spare Parts) ; Fax: +420 582 360 606

TROUBLESHOOTING

4. Remove the left hand wheel by removing screw **J** and sliding the wheel off. Remove the handle by removing screw **K** located inside the handle. Re-install the handle on the opposite side of the left hand wheel. Re-install hand wheel reversed on shaft as shown below.

5. When the hand wheel is turned, it will reverse the rotation of the main cam. The obstruction may be removed. Once the obstruction has been, re-install the left hand wheel and the stitch feed housing by starting with step 4 and working back to step 1.

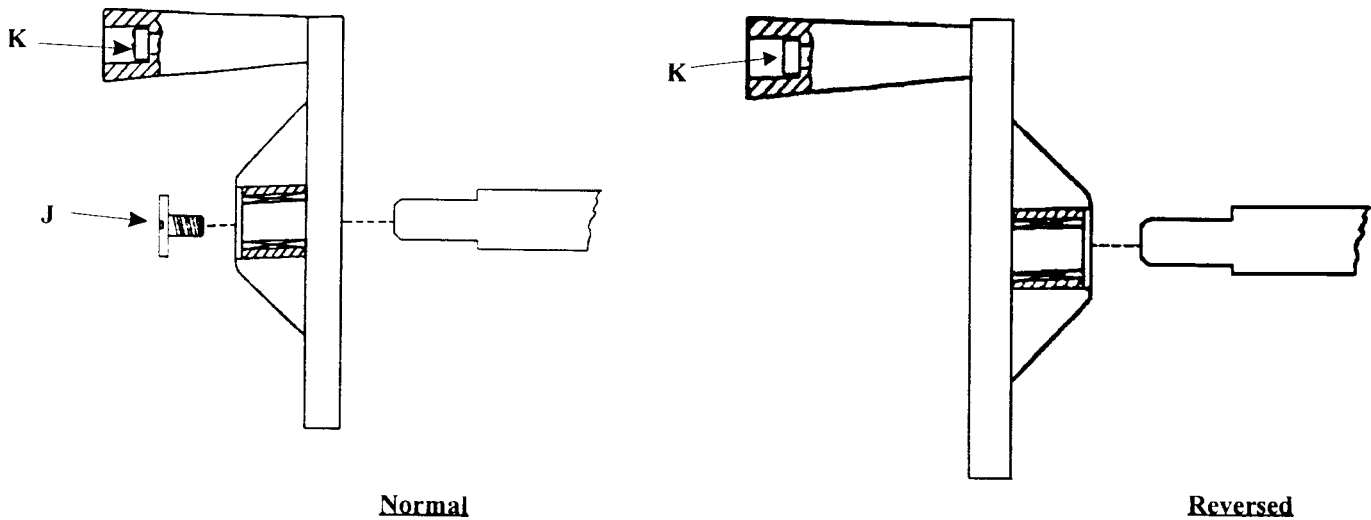

Normal

Reversed

TROUBLESHOOTING

SYMPTOM	POSSIBLE CAUSE	POSSIBLE SOLUTION
Motor fails to start.	No power to the motor	Check electrical plug and wiring
	Incorrect voltage	Check with a voltage meter
	Transformer	Check transformer output
	Faculty motor starter	Replace starter
Motor started and ran for a short period of time, then stopped.	Left wheel dog will not engage drive hub.	Recheck stop motion
	Spring on shifting lever weak or broken.	Check and replace
	Drive hub broken	Replace the drive hub
	Clamp screw on shifter spool loose	Adjust and tighten the timing on the left hand wheel in relation to rocker shaft and lever.
	Excessive cutting pressure	Re-adjust cutting pressure
	Belt tension is not correct	Re-adjust tension
	Rocker arm out of adjustment	Adjust roll pressure on length gauge Adjust rocker arm and stop motion Adjust timing of left hand wheel in relation to stop wheel release
	Spring on clutch is broken	Replace spring
The machine fails to cycle	Dirt in sector teeth	Clean sector teeth and test by rotating complete assembly back and forth
	Incorrect motor rotation	Check power supply and wiring
	Belts has fallen off	Re-install belt

Revised 09/2004

e-mail: service@amfreece.cz; parts@amfreece.cz; website: www.amfreece.com

Phones: +420 582 309 146 (Service), +420 582 309 286 (Spare Parts) ; Fax: +420 582 360 606

TROUBLESHOOTING

SYMPTOM	POSSIBLE CAUSE	POSSIBLE SOLUTION
Uneven feeding	Left wheel does not turn freely on lower rear shaft	Oil thoroughly hole in screw located on left hand end of shaft
	Main cam friction too tight or too loose	Adjust
	Improperly set friction collar	Adjust compression
	Feed clutch worn	Replace
Machine turning hard at eye	Dirt lodged between upper and lower sector teeth	Remove dirt
	Adjusting collar is too tight (14.4023)	Loosen nut slightly
Machine fails to stitch during cycle	Stop Motion incorrect	Check and re-adjust stop motion as needed
	Spring on clutch dog is broken	Replace spring
	Pivot of clutch dog not working freely in hole of stop wheel	Smooth pivot and clean hole in stop wheel
	Pivot pin of clutch dog broken	Replace clutch dog
	Spring on lever 10.1118 is broken	Replace spring
	Bumper faulty or not correctly adjusted	Replace or re-adjust bumper (see stop motion adjustment)
	Trip lever out of adjustment	Adjust trip lever and make sure bracket is securely against casting
	Dog 10.1117 not square to trip lever	Re-adjust dog
Noise in stop motion	Stop motion out of adjustment	Adjust stop motion

Revised 09/2004

e-mail: service@amfreece.cz ; parts@amfreece.cz ; website: www.amfreece.com

Phones: +420 582 309 146 (Service), +420 582 309 286 (Spare Parts) ; Fax: +420 582 360 606

TROUBLESHOOTING

SYMPTOM	POSSIBLE CAUSE	POSSIBLE SOLUTION
Machine fails to stop stitching	Stop motion incorrectly adjusted	Re-adjust stop motion
	Rocking lever shaft binding in head casting	Free the shaft
	Excessive side play in rocker	Adjust rocker arm; before doing so, ensure the pressure on length gauge is correct
Machine does not reach home position	Drive belts worn	Replace belts
	Excessive cutting pressure	Re-adjust cutting knife and block pressure
	Stop motion incorrectly adjusted	Re-adjust stop motion
Machine fails to stop	Stop Motion incorrectly adjusted	Re-adjust stop motion
	Switching lever spring tension too weak	Re-adjust spring tension
	Switching lever spring damaged	Replace spring
	Switching lever binding or damaged	Remove bind; replace lever
	Stud on switching lever damaged	Replace stud
	Shifter shoe worn or binding	Replace shifter shoe or remove bind
Machine fails to grip material or releases prematurely	Clamp mechanism incorrectly adjusted	Re-adjust clamp
Machine fails to release material	Machine not reaching home position	Check stop motion
	Clamp disengagement incorrectly adjusted	Re-adjust clamp disengagement

Revised 09/2004

e-mail: service@amfreece.cz; parts@amfreece.cz; website: www.amfreece.com

Phones: +420 582 309 146 (Service), +420 582 309 286 (Spare Parts) ; Fax: +420 582 360 606

TROUBLESHOOTING

SYMPTOM	POSSIBLE CAUSE	POSSIBLE SOLUTION
Uneven pressure of clamp feet	Clamp pull downs not correctly	Re-adjust clamp yoke as aligned needed
	Clamp pull downs are loose or broken	Re-tighten screws and nuts or replace
Machine fails to cut material	Damaged knife	Replace knife
	Cutting block damaged	Repair or replace cutting block
	Insufficient cutting pressure	Re-adjust pressure on cutting knife and block
	Cutting lever damaged	Replace cutting lever
	Cutting cam damaged	Replace cutting cam
	Cam follower on cutting lever damaged	Replace cam follower
Cutting lever sticks and fails to return	Faculty extension spring	Replace spring
	Sticking of pins	Re-adjust and/or lubricate pins
	Excessive pressure on cutting lever	Adjust cutting lever pressure
Uneven cutting	Clamp spreading uneven	Adjust clamp spreading
	Cutter not centered	Adjust cutter
	Cuttings steels installed incorrectly	Re-install cutting steels
	Cuttings steels not fitted to knife	See Replacement of Cutting Steel adjustment, page 1-60

Revised 09/2004

e-mail: service@amfreece.cz ; parts@amfreece.cz ; website: www.amfreece.com

Phones: +420 582 309 146 (Service), +420 582 309 286 (Spare Parts) ; Fax: +420 582 360 606

TROUBLESHOOTING

SYMPTOM	POSSIBLE CAUSE	POSSIBLE SOLUTION
Cutting stitches on a Cut After machine	Thread tension is loose	Tighten thread tension
	Insufficient clamp spreading	Adjust clamp spread
	Clamps not holding work correctly	Adjust clamps
	Cutting knife not centered	Adjust cutting knife
	Cutting steel not centered to knife	Adjust cutting steel
	Cutting of stitches occurring on both sides	Adjust the bite and cutting space Re-check looper and spreader timing
	Length of buttonhole is incorrect	Adjust the length of the buttonhole
Skipping at the junction of the “Y” of the flybar	Improper cutting space	Adjust cutting space
	Cord very hard and heavy, causing deflection of needle	Slightly increase the bite size Re-adjust loopers and spreaders
Skipping stitches	Needle incorrectly inserted	Re-insert needle
	Bent needle or burr on needle point	Check and replace needle
	Needle deflection	Correct the cause of deflection
	Too much clearance between looper and needle	Re-adjust clearance
	Incorrect timing between looper and needle	Re-adjust looper timing
	Excessive end play in looper carrier	Check for worn parts, and replace as necessary Adjust looper carrier
	Loopers are bent or worn	Replace loopers
Spreader timing incorrectly adjusted	Re-adjust spreader timing	

Revised 09/2004

e-mail: service@amfreece.cz; parts@amfreece.cz; website: www.amfreece.com

Phones: +420 582 309 146 (Service), +420 582 309 286 (Spare Parts) ; Fax: +420 582 360 606

TROUBLESHOOTING

SYMPTOM	POSSIBLE CAUSE	POSSIBLE SOLUTION
Skipping stitches (cont'd)	Too much clearance between clamp foot and needle entry point	Re-adjust clearance
	Clamp spread incorrectly adjusted	Re-adjust clamp spread
	Improper threading	Re-thread the machine
	Improper tensions	Adjust tension
Skipped stitches at sew start	Sew start thread length too short	Re-adjust upper tension start release
	Fork spreader not located over hole of eye looper	Check and re-adjust looper and spreader as necessary
	R.H. looper timing incorrectly adjusted	Re-adjust looper timing
	Too much clearance between clamp foot and needle entry point	Re-adjust clearance
	Damaged loopers and / or spreaders	Replace loopers and / or spreaders
Breakage of upper thread	Excessive upper thread tension	Re-adjust upper thread tension
	Incorrect clearance between needle and looper	Re-adjust clearance and looper
	Incorrect looper / spreader timing	Re-adjust looper and spreader timing
	Sharp edges along thread path	Polish sharp edges
	Needle is bent or incorrectly set	Replace needle or re-insert needle
	Machine not threaded properly	Re-thread the machine
Breakage of lower thread	Excessive lower thread tension	Re-adjust lower thread tension
	Left hand spreader incorrectly adjusted Refer to breakage of upper thread for other probable causes	Re-adjust spreader

Revised 09/2004

e-mail: service@amfreece.cz ; parts@amfreece.cz ; website: www.amfreece.com

Phones: +420 582 309 146 (Service), +420 582 309 286 (Spare Parts) ; Fax: +420 582 360 606

TROUBLESHOOTING

SYMPTOM	POSSIBLE CAUSE	POSSIBLE SOLUTION
Thread breaking and running back out of needle bar	Trimming improperly adjusted	Adjust trimming
	Tension improperly adjusted	Adjust tension
	Threading incorrect	Re-check threading
Needle breakage	Incorrect clearance between needle and loopers / spreaders	Re-adjust clearance
	Incorrect clearance between needle and clamp foot	Re-adjust clearance
	Needle bar height incorrectly adjusted	Re-adjust needle bar height
	Vibrator block of needle bar not square with race	Check sector adjustment
Inconsistent stitching on straight portion of b/h	Machine alignment incorrect	Re-align the machine
	Clamp spread incorrectly adjusted	Re-adjust clamp spread
	Looper and spreader timing incorrect	Re-set timing
Eye shape deformed	Lateral cam timing incorrectly adjusted	Re-adjust timing
	Cutting lever incorrectly adjusted	Re-adjust cutting lever
	Gimp pulling hard through throat plate	Open gimp hole as needed. Re-adjust gimp pull back (cord trim only)
	Incorrect race swing	Check race swing for 180 degree turn and for squareness
	Clamp spread incorrect	Adjust clamp plates and clamp spread

Revised 09/2004

e-mail: service@amfreece.cz; parts@amfreece.cz; website: www.amfreece.com

Phones: +420 582 309 146 (Service), +420 582 309 286 (Spare Parts) ; Fax: +420 582 360 606

TROUBLESHOOTING

SYMPTOM	POSSIBLE CAUSE	POSSIBLE SOLUTION
Row of stitching is cut by knife after sewing cycle is complete	Inadequate cutting width	Re-adjust cutting width
	Cutting lever incorrectly adjusted	Re-adjust cutting lever
	Incorrect clamp spread	Re-adjust clamp spread
	Buttonhole length too short	Re-adjust length gauge
Decreased buttonhole quality	The functional and aesthetic of a buttonhole can be influenced by the following factors:	See appropriate adjustments
	Density of stitches	
	Number of stitches in a buttonhole eye	
	Degree of material spreading	
	Distance between stitch line and buttonhole axis	
	Incorrect timing of loopers and spreaders	
Pulling up stitches	Thread and material can affect the look of a buttonhole	
	Upper and lower thread tensions	Adjust upper and lower tensions
	Incorrect timing of loopers/spreaders	Re-adjust the timing

Revised 09/2004

e-mail: service@amfreece.cz ; parts@amfreece.cz ; website: www.amfreece.com

Phones: +420 582 309 146 (Service), +420 582 309 286 (Spare Parts) ; Fax: +420 582 360 606