



**MODEL S-311**

**ELECTRONIC EYELET BUTTONHOLE  
MACHINE**

**PARTS AND SERVICE MANUAL**

**MACHINE SERIAL No.**

**PART NUMBER 97. 1930.0.001**

This manual is valid from the machine serial No.: J190410





**MODEL S-311**

**ELECTRONIC EYELET BUTTONHOLE  
MACHINE**

**PARTS AND SERVICE MANUAL**

**MACHINE SERIAL No.**

**PART NUMBER 97. 1930.0.001**

This manual is valid from the machine serial No.: J190410



**AMF® REECE**  
*Better Ideas, Better Made*

**S-311**

97.1930.0.001 ELECTRONIC EYELET BUTTONHOLE MACHINE  
PARTS AND SERVICE MANUAL

**AMF® REECE**  
*Better Ideas, Better Made*

**S-311**

97.1930.0.001 ELECTRONIC EYELET BUTTONHOLE MACHINE  
PARTS AND SERVICE MANUAL

**AMF® REECE**  
*Better Ideas, Better Made*

**S-311**

97.1930.0.001 ELECTRONIC EYELET BUTTONHOLE MACHINE  
PARTS AND SERVICE MANUAL

**AMF® REECE**  
*Better Ideas, Better Made*

**S-311**

97.1930.0.001 ELECTRONIC EYELET BUTTONHOLE MACHINE  
PARTS AND SERVICE MANUAL

**AMF® REECE**  
*Better Ideas, Better Made*

**S-311**

97.1930.0.001 ELECTRONIC EYELET BUTTONHOLE MACHINE  
PARTS AND SERVICE MANUAL

**AMF® REECE**  
*Better Ideas, Better Made*

**S-311**

97.1930.0.001 ELECTRONIC EYELET BUTTONHOLE MACHINE  
PARTS AND SERVICE MANUAL





## LIMITED WARRANTY ON NEW AMF REECE EQUIPMENT

### Warranty provisions:

A ninety (90) day limited service labor warranty to correct defects in installation, workmanship, or material without charge for labor. This portion of the warranty applies to machines sold as "installed" only.

A one (1) year limited material warranty on major component parts to replace materials with defects. Any new part believed defective must be returned freight prepaid to AMF Reece, Inc. for inspection. If, upon inspection, the part or material is determined to be defective, AMF Reece, Inc. will replace it without charge to the customer for parts or material.

Service labor warranty period shall begin on the completed installation date. Material warranty shall begin on the date the equipment is shipped from AMF Reece, Inc.

### Exclusions:

Excluded from both service labor warranty and material warranty are: (1) Consumable parts which would be normally considered replaceable in day-to-day operations. These include parts such as needles, knives, loopers and spreaders. (2) Normal adjustment and routine maintenance. This is the sole responsibility of the customer. (3) Cleaning and lubrication of equipment. (4) Parts found to be altered, broken or damaged due to neglect or improper installation or application. (5) Damage caused by the use of non-Genuine AMF Reece parts. (6) Shipping or delivery charges.

There is no service labor warranty for machines sold as "uninstalled".

Equipment installed without the assistance of a certified technician (either an AMF Reece Employee, a Certified Contractor, or that of an Authorized Distributor) will have the limited material warranty only. Only the defective material will be covered. Any charges associated with the use of an AMF Reece Technician or that of a Distributor to replace the defective part will be the customer's responsibility.

NO OTHER WARRANTY, EXPRESS OR IMPLIED, AS TO DESCRIPTION, QUALITY, MERCHANTABILITY, and FITNESS FOR A PARTICULAR PURPOSE, OR ANY OTHER MATTER IS GIVEN BY SELLER OR SELLER'S AGENT IN CONNECTION HEREWITH. UNDER NO CIRCUMSTANCES SHALL SELLER OR SELLER'S AGENT BE LIABLE FOR LOSS OF PROFITS OR ANY OTHER DIRECT OR INDIRECT COSTS, EXPENSES, LOSSES OR DAMAGES ARISING OUT OF DEFECTS IN OR FAILURE OF THE EQUIPMENT OR ANY PART THEREOF.

### WHAT TO DO IF THERE IS A QUESTION REGARDING WARRANTY

If a machine is purchased through an authorized AMF Reece, Inc. distributor, warranty questions should be first directed to that distributor. However, the satisfaction and goodwill of our customers are of primary concern to AMF Reece, Inc. In the event that a warranty matter is not handled to your satisfaction, please contact the appropriate AMF Reece office:

#### Europe/Africa/Americas

Prostejov, Czech Republic  
Phone: (+420) 582-309-275  
Fax: (+420) 582-360-608  
e-mail: [service@amfreece.cz](mailto:service@amfreece.cz)

#### Southwest Asia

Istanbul, Turkey  
Phone: (+90) 212-465-0707  
Fax: (+90) 212-465-0711  
e-mail: [amfreeceturkey@superonline.com](mailto:amfreeceturkey@superonline.com)

#### Southeast Asia

Kowloon, Hong Kong  
Phone: (+852) 2787-2273  
Fax: (+852) 2787-5642  
e-mail: [amfreece@netvigator.com](mailto:amfreece@netvigator.com)





# Warranty Registration Card

*(Please Fax or Mail immediately after installation)*

**Note: All Warranty Claims Void, unless Registration Card on file at AMF Reece HQ**

Machine model number:

*(S101, S100, S104, S311, Decostitch, S4000 BH, etc)*

Manufacturer's serial or production number:

## **Installation Site Information:**

Customer's Name:

Customer's Mailing Address:

Customer's Telephone Number:

Supervising Mechanic's or Technician's Name:

Signature of Supervising Technician:

AMF Reece Technician's Name:

AMF Reece Technician's Signature:

Type of garment produced at this location?

Average Daily Production Expected from this machine?

*(number of buttonholes, jackets sewn, pants produced, buttons sewn, etc)*

Any special requirements required at this location?

What other AMF Reece Machines are at this location?

How can we serve you better?

**Tovární 582, 796 25 Prostějov, Czech Republic**

**Fax: +420 582 360 606, e-mail: [service@amfreece.cz](mailto:service@amfreece.cz), website: [www.amfreece.com](http://www.amfreece.com)**



## TABLE OF CONTENTS

---

### A - INTRODUCTION

1. Basic information .....	1-1
2. Safety labels and device .....	1-2
3. General machine parts descriptions .....	1-3
4. Specification .....	1-4
5. Buttonhole description .....	1-6
6. Instructions for operator safety and maintenance of the machine S-311 .....	1-7
7. Special device .....	1-9
7.1.Light .....	1-9
7.2.Adjustable cutting length steel (ACL) .....	1-9
7.3.Manual machine control .....	1-9

### B - MACHINE ASSEMBLY

1. Content of the shipping box .....	1-10
2. Table adjustment .....	1-10
3. Connection of the machine head with the control box .....	1-12
4. Belt tension .....	1-13
5. Power and air connection .....	1-14
6. Thread stand installation .....	1-15
7. Lubrication .....	1-16

### C - PROPER APPLICATION

1. Power up / home position .....	1-17
2. Needle installation .....	1-18
3. Threading .....	1-19

### D - MACHINE CONTROLS

1. Operation .....	1-22
2. Needle instalation .....	1-18
3. The buttonhole setting .....	1-25
3.1. Setting the parameters of the eye .....	1-25
3.2. Setting the first and the second row of stitches .....	1-26
3.3. Setting a bar .....	1-27
4. The sewing speed setting .....	1-28
5. Parameters saving .....	1-28
6. Copying adjusted perameters under new number .....	1-29
7. Trimm thread end lengths adjustment .....	1-29
8. Setting the cutting .....	1-30
9. Service mode .....	1-31
10. Cycle mode .....	1-32
11. Manual cut mode .....	1-33

Revised 03/2006

E-mail: [service@amfreece.cz](mailto:service@amfreece.cz); [parts@amfreece.cz](mailto:parts@amfreece.cz); website: [www.amfreece.com](http://www.amfreece.com)

Phones: +420 582 309 146 (Service), +420 582 309 286 (Spare Parts); Fax: +420 582 360 606

## TABLE OF CONTENTS

---

### E - STANDARD MACHINE ADJUSTMENT

1. Standard buttonhole shapes set by the manufacturer .....	1-34
2. The sewing drive sensor plates adjustment .....	1-35
3. The bedplate home position adjustment .....	1-36
4. The race mechanism adjustment .....	1-37
5. The sewing mechanism height control .....	1-38
6. Mechanism adjustment for material clamping .....	1-39
7. Spreading of a material .....	1-40
8. Adjustment of the cutting mechanism .....	1-41
9. Setting the needle bar height .....	1-43
10. Spreader and looper cam adjustment .....	3-44
11. Loopers adjustment .....	1-44
12. Spreaders adjustment .....	1-45
13. Adjustment of the bite mechanism .....	1-46
14. Upper thread trimming mechanism - AF/LTT .....	1-47
15. Adjustment of the upper thread pick-up height .....	1-48
16. Upper trimming and lower interception - CT .....	1-49
17. The gimb draw-off adjustment -CT .....	1-51
18. The trimming mechanism adjustment - LTT .....	1-52
19. Adjustment of the adjustable cutting steel holder .....	1-55
20. Setting the thread tension and thread draw off .....	1-56

### F - MACHINE MAINTENANCE

1. Cleaning and maintenance of the machine .....	1-57
2. Periodic maintenance .....	1-59
3. Scheme of the lubrication distribution .....	1-60
4. Machine lubrication .....	1-61
5. Machine disposal .....	1-63

### G - DOCUMENTATION

Flow diagram .....	1-64
--------------------	------

## MODEL S-311+I OPERATING INSTRUCTIONS

Revised 03/2006

E-mail: [service@amfreece.cz](mailto:service@amfreece.cz); [parts@amfreece.cz](mailto:parts@amfreece.cz); website: [www.amfreece.com](http://www.amfreece.com)

Phones: +420 582 309 146 (Service), +420 582 309 286 (Spare Parts); Fax: +420 582 360 606

## A - INTRODUCTION

### 1. BASIC INFORMATION

Sewing machine S-311 is determined to sew buttonholes for outwears. Buttonholes type are listed on page no. 1-6. The sewing machine S-311 is designed and produced to be simple for operation and very reliable. Important design goals have been made to provide a safe machine that is simple and inexpensive to maintain.

Sewing machine S-311 has four basic models: AF, CT, LTT and RDE. Each model can be combined with ACL, except the model RDE.

Special electronic and mechanical safety devices protect the operator and the machine. There is a special power lock out switch that permits the machine to be locked in the off position, so that it cannot be cycled accidentally. There is a low air pressure detector that will not permit machine operation if air pressure is dangerously low.

There are safety-warning labels on the machine in all areas that require special care. These must not be removed. If they are lost replace them immediately.

You are the most important safety equipment of all. Be sure you understand the proper operation of the machine. Never remove safety mechanisms or labels. We have made every effort to provide the safest possible machine, but without complete knowledge of how this machine operates, and the use of proper care by the operator, this machine can cause serious injury or death. That is why there are safety warnings throughout these instructions that carry one of these messages.

Machine types are listed in the table on the manual page no. 1-4, 1-5.

**DANGER!** Possible loss of life.

**WARNING!** Possible serious injury or machine damage.

**NOTICE!** Possible injury or machine damage.

We recommend that service workers from AMF Reece oversee the installation and initial training of your mechanics and operators.

**The most effective safety precaution is a well-managed safety program. Be sure those who use this machine are properly trained. Never disable safety equipment.**

**Always wear safety goggles when operating or servicing the machine.**

EXPLANATION OF ABBREVIATIONS IN THE MANUAL TEXT	
<b>CA</b>	Cut After
<b>CB</b>	Cut Before
<b>AF</b>	Adjustable Flybar
<b>CT</b>	Cord Trimming of all threads - short tail of lower thread
<b>LTT</b>	Cord Trimming of all threads - long tail of lower thread
<b>ACL</b>	Adjustable Cutting Length (Cut)

## A - INTRODUCTION

### 2. SAFETY LABELS AND DEVICE

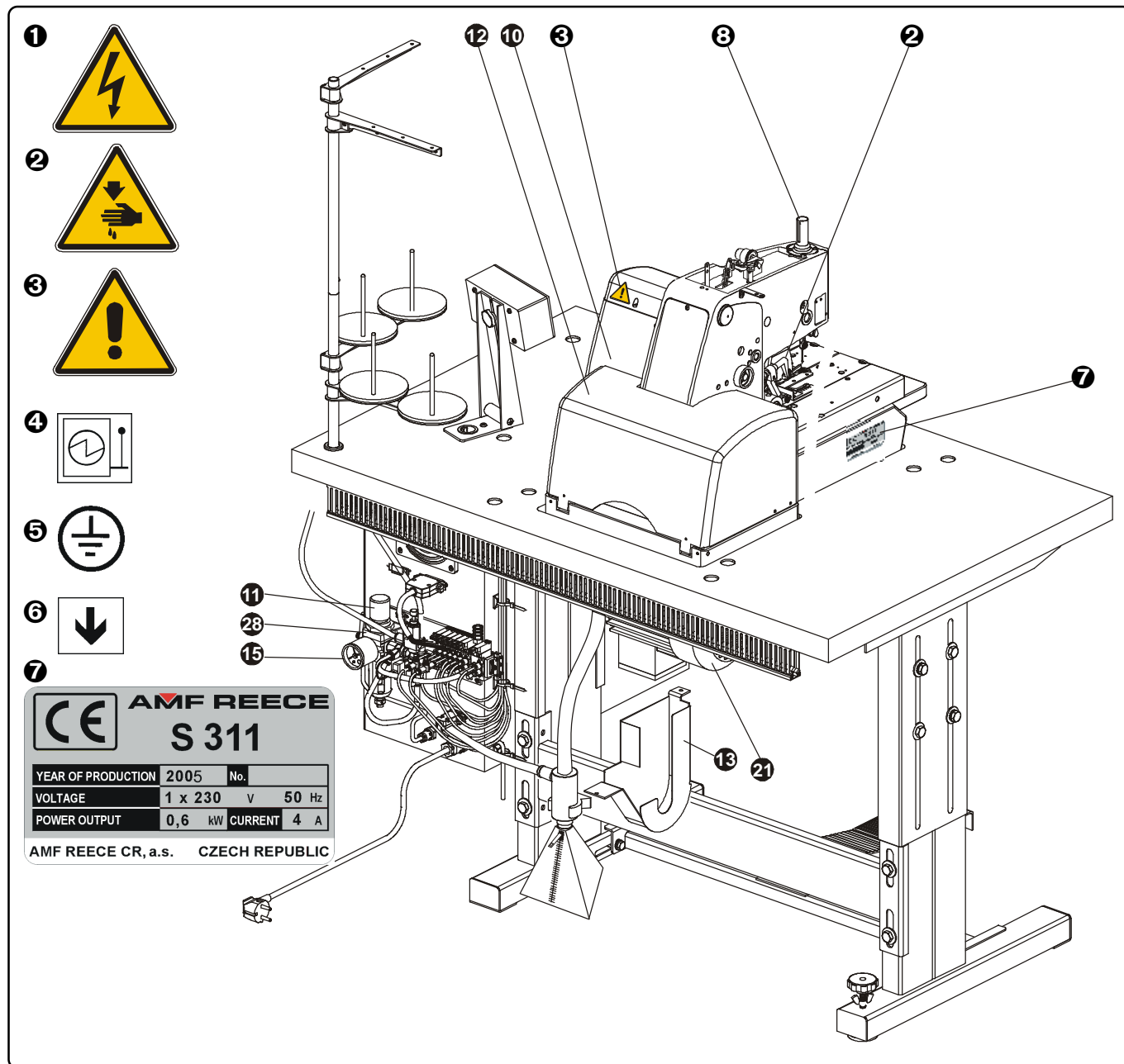

- |   |  |
|---|--|
| <b>1</b> Warning                        | <b>8</b> Needle bar cover              |
| <b>2</b> Danger possible injury         | <b>9</b> Eye guard                     |
| <b>3</b> Covers removed possible injury | <b>10</b> Drive belt cover             |
| <b>4</b> Switch                         | <b>11</b> Air pressure adjustment knob |
| <b>5</b> Grounding                      | <b>12</b> Rear cover                   |
| <b>6</b> Rotational direction           | <b>13</b> Motor pulley cover           |
| <b>7</b> Standard label                 | <b>14</b> Foot pedal                   |
|   | <b>15</b> Air pressure switch          |

## A - INTRODUCTION

### 3. GENERAL MACHINE PARTS DESCRIPTIONS

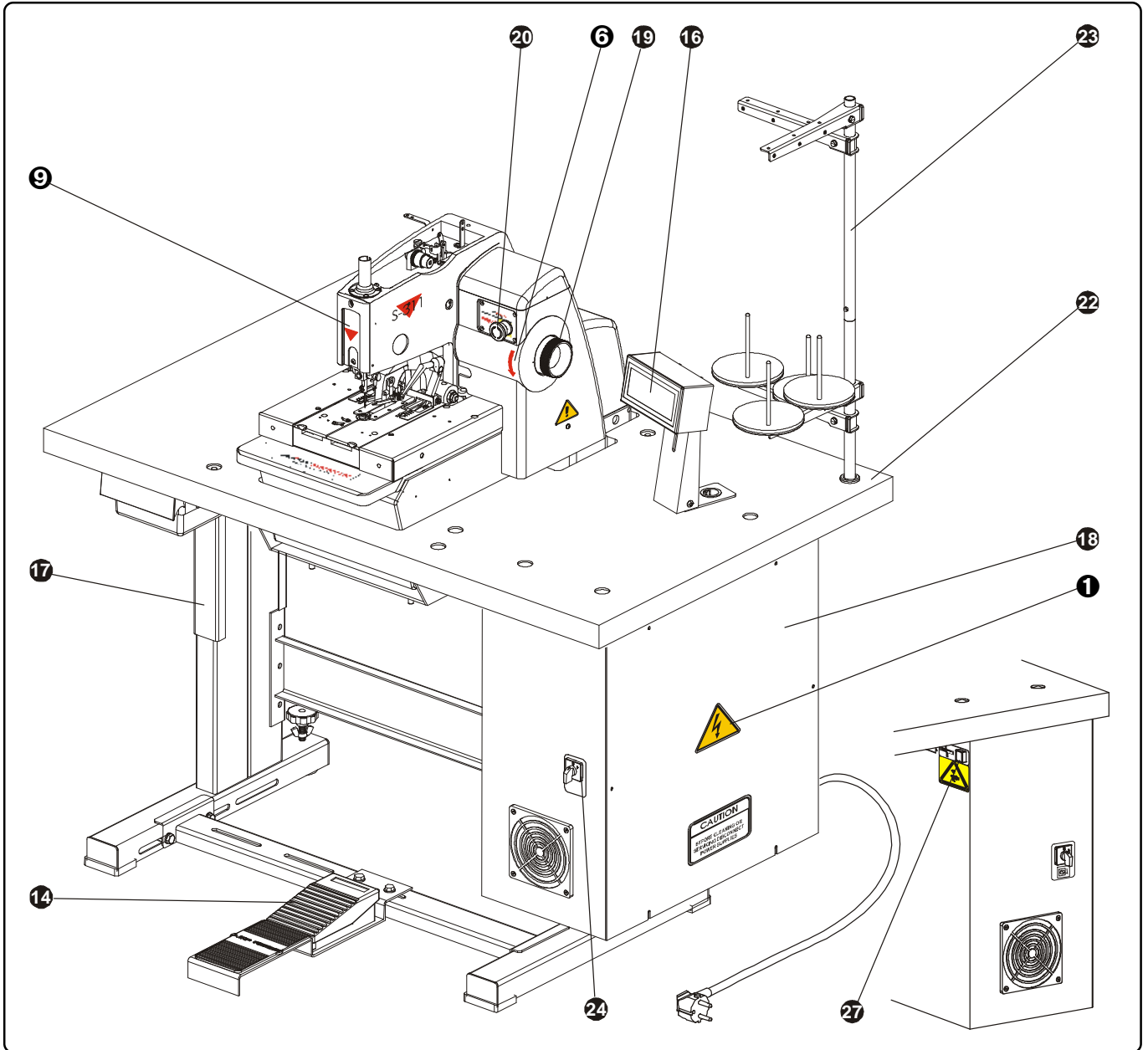





- 16 Display
- 17 Table
- 18 Control box
- 19 Hand wheel
- 20 Emergency Stop button
- 21 Motor
- 22 Table top
- 23 Thread stand

- 24 Main power switch
- 27 Cutting activation button
- 28 Air pressure regulator

## A - INTRODUCTION

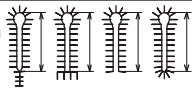
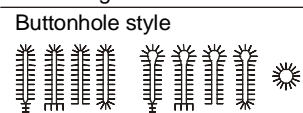
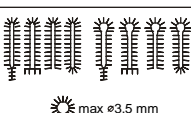
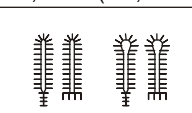
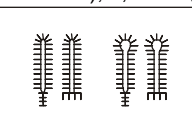
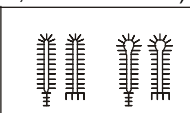
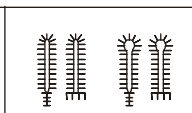
### 4. SPECIFICATION

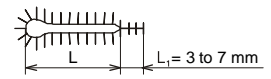
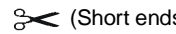
**S-311** Elektronick buttonhole machine with chain stitch is possible to use for men`s and women`s wear. Possible to use gimp thread, not in round eye.

Machine type/model	AF	CT 16 - 20 mm	CT 20 - 24 mm	CT 24 - 28 mm	CT 28 - 32 mm
Sewing speed	1000 to 2000 stitches/min (500 to 1000 rev/min of the drive shaft)				
The length of hole 	10 to 50 mm	16 to 20 mm	20 to 24 mm	24 to 28 mm	28 to 32 mm
Stitch Density	0,5 to 2,0 mm (increments of 0,1 mm)				
Number of stitches in the eye	4 to 20				
Bite Range Electronic	2,1 mm ( $\pm 0,3$ mm electronic); 2,7 mm ( $\pm 0,3$ mm electronic)				
Buttonhole style 					
Eye type	No eye; 2,2 x 3,0 mm; 2,8 x 4,2 mm; 3,0 x 4,6 mm; 3,2 x 5,0 mm; 3,4 x 4,2 mm				
Flybar length	3,0 - 20,0 mm	See section D 3.3			
Length of the cross bar	4 to 8 mm	4 to 6 mm			
Cross bar density	0,5 to 1,5 mm	0,5 to 1,5 mm			
Number of stitches in the round end	4 to 20	—			
Clamp foot height (max)	12 mm				
Maximum work thickness	in 8,0 mm				
Buttonhole Cutting Mode	Cut before (CB), cut after (CA), no cut (OFF)				
Cutting Space	- 0,50 to + 1,2 mm				
Cut position (Y axis)	$\pm 1,5$ mm				
Bedplate movement	64 mm				
Needle system	02.0558.0.111 (Nm 100)	02.0558.1.112 (Nm 110)			
Recommended threads*	80, 100, 120, gimp size 30.				
Upper thread trimming 					
Lower thread and gimp trimming 	—	 (Short ends) 			
Cutting space 	—	L = 16 to 20 mm L+L <sub>1</sub> = 23 to 27 mm	L = 20 to 24 mm L+L <sub>1</sub> = 27 to 31 mm	L = 24 to 28 mm L+L <sub>1</sub> = 31 to 35 mm	L = 28 to 32 mm L+L <sub>1</sub> = 35 to 39 mm
Operating Condition	according to IEC 364-3, IEC 364-5-51 temperature from +5°C to 40°C, relative air humidity from 30 to 8 0%				
Air pressure	0,55 MPa = 80 PSI				
Machine db Level	L <sub>WA</sub> =86,9db; L <sub>PA</sub> =74,8 db; Noise measurement according to EN ISO 3746:1995				
Machine Head Dimension	530 mm (height) x 370 mm (width) x 560 mm (depth)				
Machine Head Weight	64 kg				
Table Dimensions	730 mm (height) x 1100 mm (width) x 700 mm depth) + 150 mm distance				
Machine Weight	175 kg				
Electrical requirements	1NPE~60Hz 230 V/TN/S; 1NPE~50Hz 230 V/TN/S				
Line Circuit Breaker	Min. 10A Characteristic C (EN60947-2)				

\* **Note:** If a customer uses thread size 100 and less, the manufacturer recommends to use the left looper 17.0069.4.019  
If you use poor quality threads on the machine, the thread can burn at the needle (producer recommend decrease machine`s speed).



## A - INTRODUCTION

CT 16 - 32 mm	LTT	RDE	Machine type/model
1000 to 2000 stitches/min (500 to 1000 rev/min of the drive shaft)			Sewing speed
16 to 32 mm	10 to 36 mm	—	The length of hole
0,5 to 2,0 mm (increments of 0,1 mm)			Stitch Density
4 to 20		8 to 60	Number of stitches in the eye
2,1 mm (± 0,3 mm electronic); 2,7 mm (± 0,3 mm electronic)			Bite Range Electronic
Buttonhole style	Buttonhole style	Buttonhole style	Buttonhole style
No eye; 2,2 x 3,0 mm; 2,8 x 4,2 mm; 3,0 x 4,6 mm; 3,2 x 5,0 mm; 3,4 x 4,2 mm		∅ 2 to 7 mm	Eye type
See section D 3.3		—	Flybar length
4-6 mm	4-8 mm	—	Length of the cross bar
0,5 - 1,5 mm			Cross bar density
—			Number of stitches in the round end
12 mm		5 mm	Clamp foot height (max)
in 8,0 mm		1,5 to 2,5 mm	Maximum work thickness
Cut before (CB), cut after (CA), no cut (OFF)			Buttonhole Cutting Mode
- 0,50 to + 1,2 mm		—	Cutting Space
± 1,5 mm		—	Cut position (Y axis)
64 mm		62,5 mm	Bedplate movement
0.0558.1.112 (Nm 110)	0.0558.0.111 (Nm 100)		Needle system
80, 100, 120, gimp size 30.			Recommended threads*
			Upper thread trimming
(short ends)	(long ends)	—	Lower thread and gimp trimming
			Cutting space
according to IEC 364-3, IEC 364-5-51 temperature from +5°C to 40°C, relative air humidity from 30 to 80%			Operating Condition
0,55 MPa = 80 PSI			Air pressure
$L_{WA}=86,9\text{db}$ ; $L_{PIA}=74,8\text{ db}$ ; Noise measurement according to EN ISO 3746:1995			Machine db Level
530 mm (height) x 370 mm (width) x 560 mm (depth)			Machine Head Dimension
64 kg			Machine Head Weight
730 mm (height) x 1100 mm (width) x 700 mm depth + 150 mm distance			Table Dimensions
175 kg			Machine Weight
1NPE-60Hz 230 V/TN/S; 1NPE-50Hz 230 V/TN/S			Electrical requirements
Min. 10A Characteristic C (EN60947-2)			Line Circuit Breaker

## A - INTRODUCTION

### 5. BUTTONHOLE DESCRIPTION

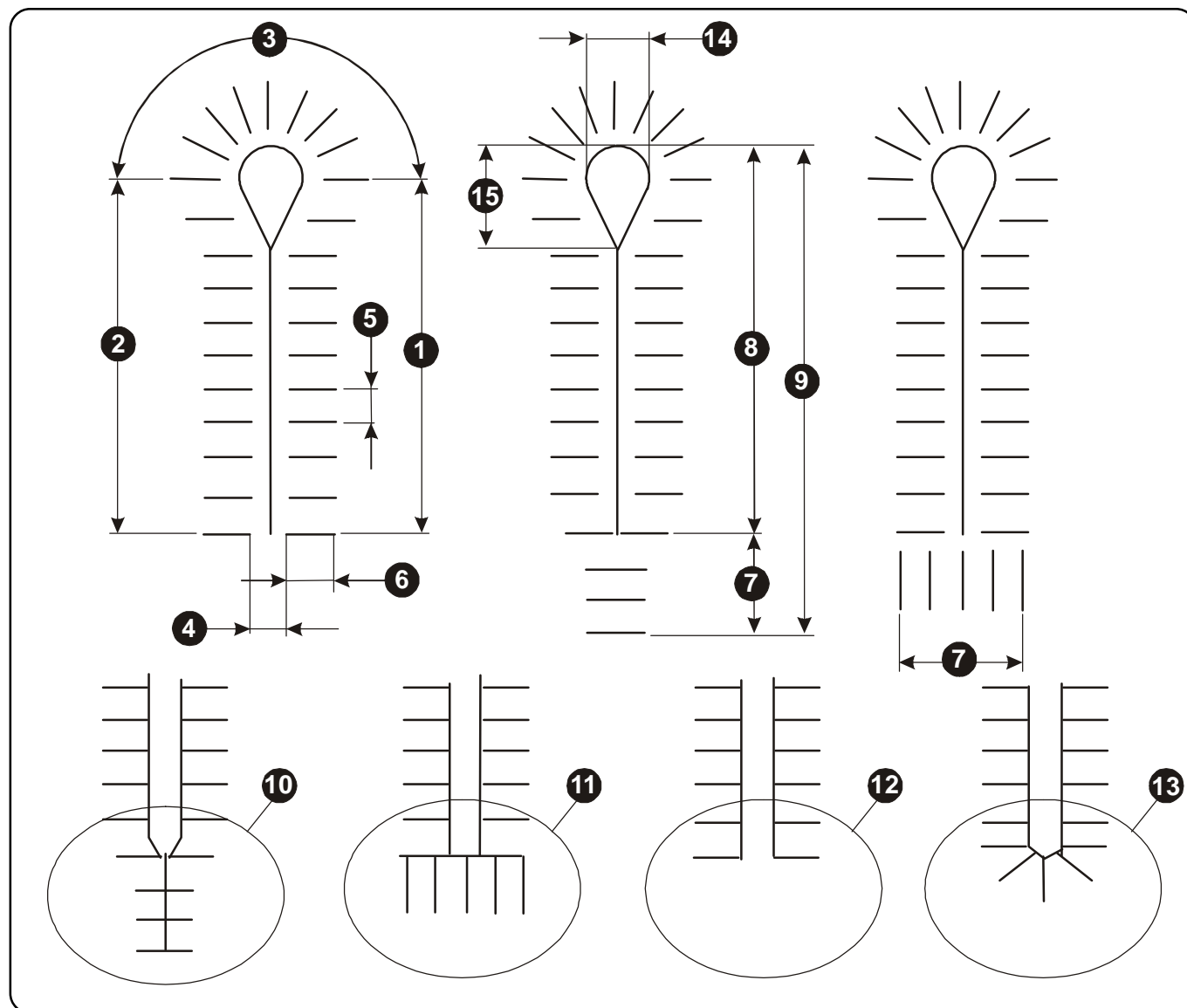

- |                              |                            |
|------------------------------|----------------------------|
| ① The first row of stitches  | ⑨ The length of buttonhole |
| ② The second row of stitches | ⑩ Fly bar AF               |
| ③ Eye                        | ⑪ Cross bar CRB            |
| ④ Cutting space              | ⑫ Open End                 |
| ⑤ Stitch density             | ⑬ Round End RDE            |
| ⑥ Bite size                  | ⑭ Buttonhole width         |
| ⑦ The length of a bar        | ⑮ Buttonhole length        |
| ⑧ The length of cutting      |                            |

## A - INTRODUCTION

### 6. INSTRUCTIONS FOR OPERATOR SAFETY AND MAINTENANCE OF THE MACHINE S-311

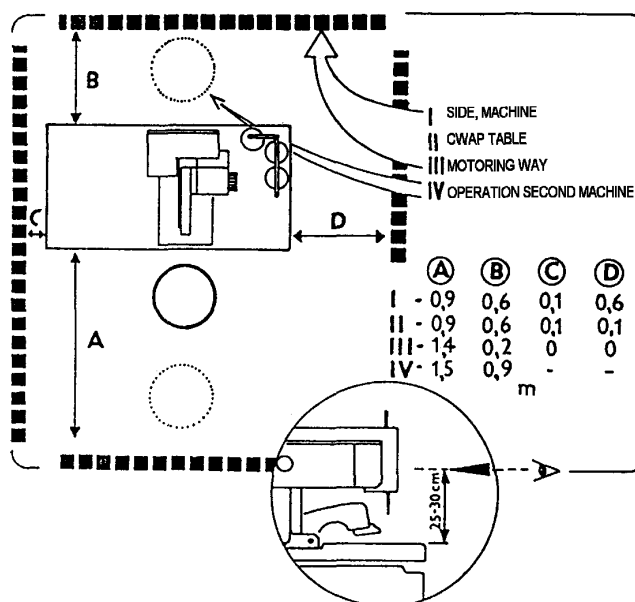

When installing the machine the manufacturer recommends the minimum clearance mentioned above around the machine. Read all of the instructions that follow. **DO NOT PUT THE MACHINE INTO OPERATION UNTIL YOU ARE COMPLETELY FAMILIAR WITH ALL INSTALLATION AND OPERATING INSTRUCTIONS.**

#### **DANGER!**

- Before connecting the machine to the power supply, be positive that all safety covers are correctly installed.
- Always engage the power lockout switch, and disconnect the main power supply, before removing any safety covers.
- Never connect the machine to the power supply when any cover is removed.
- It is forbidden to disconnect all connectors when the machine is switched on and connected to the power supply. *The electrical components and motors can be damaged.*

#### **WARNING!**

- Locate the Emergency Stop button. Be sure you know how to use it.
- Be sure that you have a reliable and uniform power supply.
- Be sure that all electrical cables are in good condition and have no signs of damage to avoid electrical shock.
- If any covers become damaged, they must be repaired or replaced immediately.
- Do not touch moving parts of the machine while it is operating.
- Keep clear of the needle.
- Always switch off the main power before changing the needle.
- Before cleaning the machine or performing service to the machine, engage the power lock out switch or disconnect the main power supply.
- When the machine is not in use engage the power lock out switch or disconnect the main power supply.

## A - INTRODUCTION

---

- When this machine is used incorrectly, or is incorrectly maintained, it can be dangerous.
- Everyone who uses this machine, or maintains this machine, must be completely familiar with this manual.

### **CAUTION!**

- Perform all regular service as described in this manual.
- If there is any problem with the power supply, turn off the main power switch.
- Do not remove, paint over, damage or in any way change safety labels. If a safety label cannot be easily read, replace it.
- Long hair and loose clothing may be dangerous near any machinery. Always contain long hair and avoid loose clothing, so that it cannot be caught by machinery and cause injury.
- Never use this machine while under the influence of drugs or alcohol.
- If anything seems to be operating incorrectly in the machine call for maintenance assistance immediately.
- Be sure that there is adequate light for safe operation. A normal minimum light level is 750 lux.

## A - INTRODUCTION

### 7. SPECIAL DEVICE

#### 7.1. Working light

- the customer can order the light (order number 12.0008.4.875)

**Warning** — It is necessary to disconnect the machine from the main wire before installing the light.

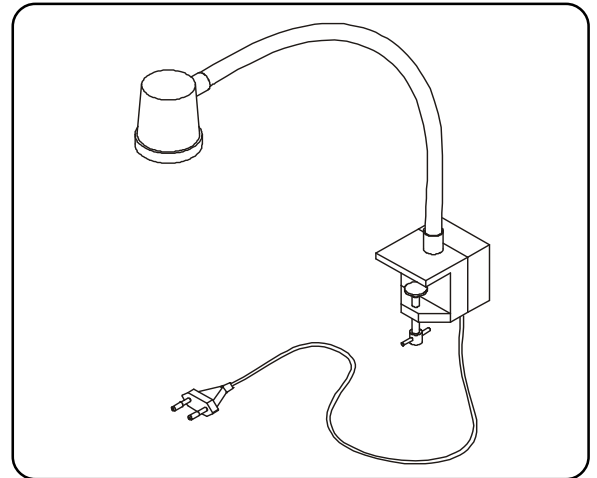

#### 7.2. Adjustable cutting length steel (ACL)

- the modification AF, CT, LTT allows sewing buttonholes in range **16-35 mm** (with the limitation according to the machine type) without changing the cutting steels
- moving cutting steel can be ordered under the no. 03.5519.0.011 - for machines which do not have this cutting steel at its equipment only (the order includes moving cutting steel and components related to it; the company is recommending AMF Reece service technician)

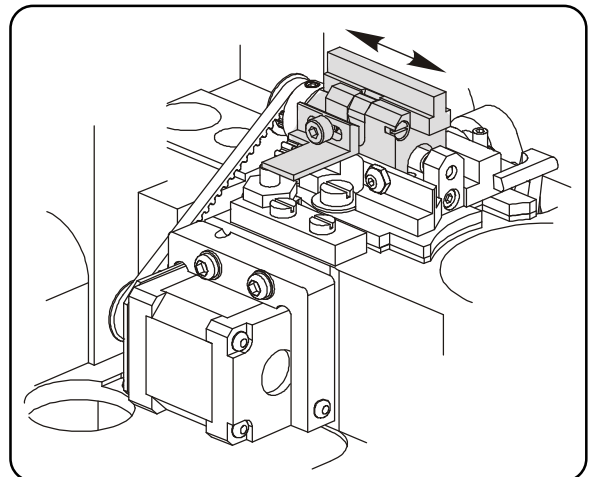

Machine types with possible usage of moving cutting steels:

- standard - AF/ACL, CT/ACL, LTT/ACL
- to order - AF, CT, LTT  
*(if the customer has those machines and wants to use ACL, he must to order the components related to this modification)*

#### 7.3. Manual machine control

- order number 03.5519.0.007
- allows to change the foot machine control for manual by switch installation on the table and changing the cables

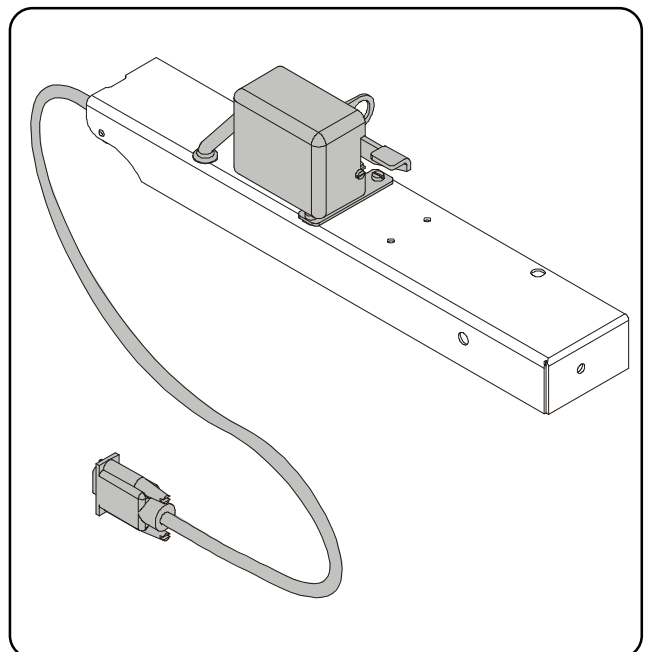

## B - MACHINE ASSEMBLY

### 1. CONTENT OF THE SHIPPING BOX

- 1.1. If it is not mentioned otherwise during ordering, the shipping container usually contains:
- assembled machine on the stand with electroinstalation
  - box with the accessories (specification in the spare parts section)
  - dis-assembled thread stand ❶
  - operation manual with the spare parts manual

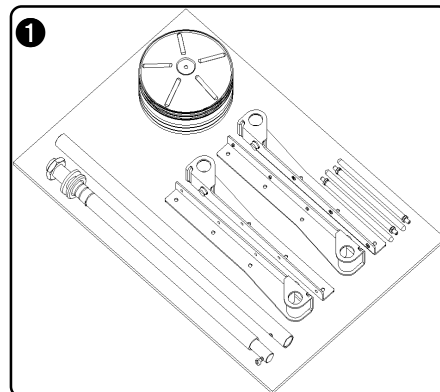

- 1.2. When unpacking the container, follow labels which are on a cover.

**CAUTION:** If the container was damaged during the transport, inform the carrier. Check the contents of the container with order. In the event of an error, immediately inform the manufacturer- late notification of an error in shipment may result in loss of claim.

### 2. TABLE ADJUSTMENT

- 2.1. After you will unpack the machine, move the machine to its appointed place. The machine is supplied with the stand with standart height for working in seat. For another stand implementation is necessary to make an agreement with the customer. The recommended height of the stand (table) is 870 mm. Tighten the screws ❷ very well.
- 2.2. To stabilize the table, use the floor pads ❸, which are controlled by hand screw ❹. Check the levelness of the adjusted table.
- 2.3. Eliminate the shipping band ❺, which holds the head in place. If transporting machine to a different location, it is necessary to fasten the table to prevent shifting in transit.

## B - MACHINE ASSEMBLY

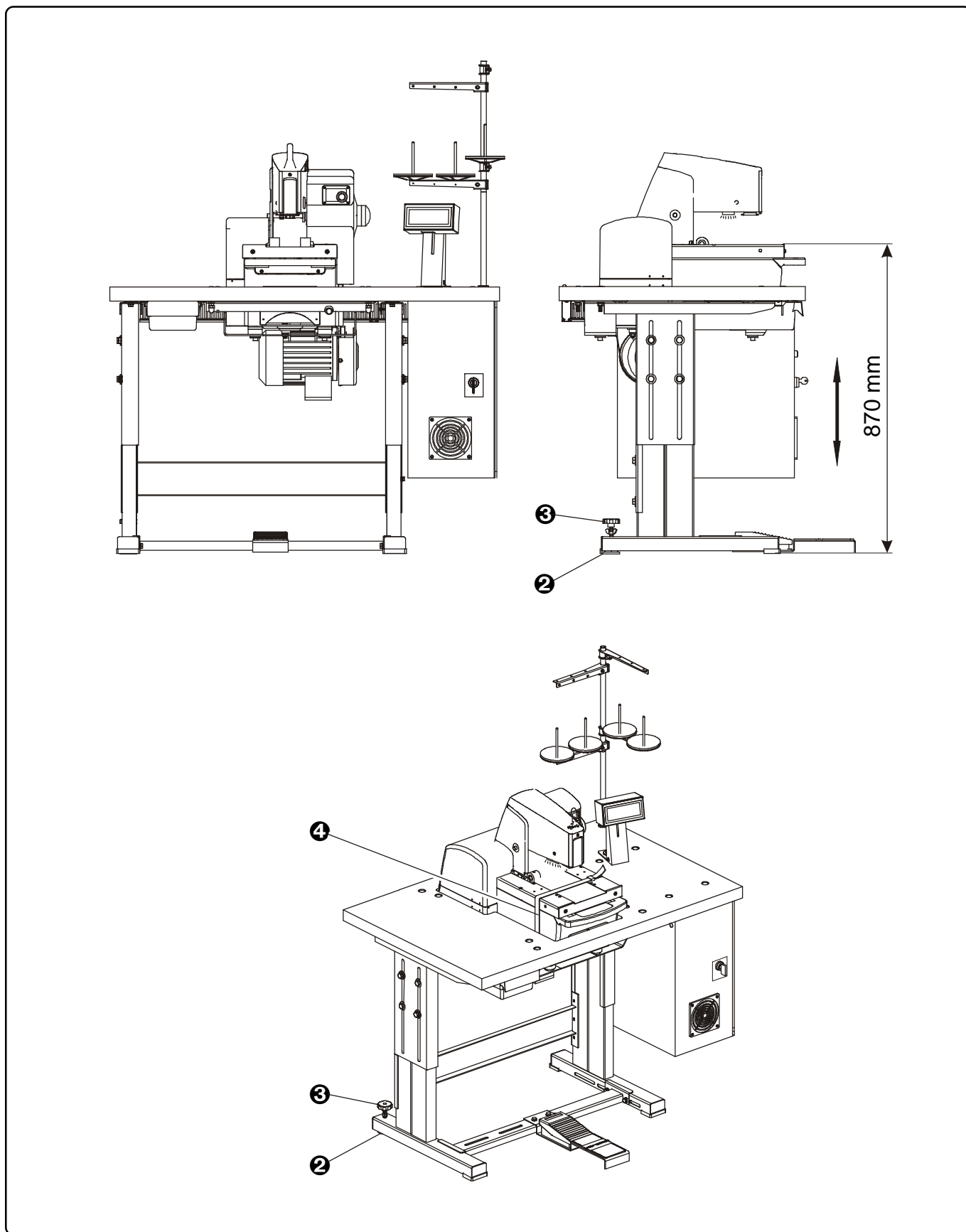

## B - MACHINE ASSEMBLY

### 3. CONNECTION OF THE MACHINE HEAD WITH THE CONTROL BOX

3.1. The control box ❶ contains the control system, regulator ❷ and valve terminal ❸ for controlling the pneumatic cylinders.

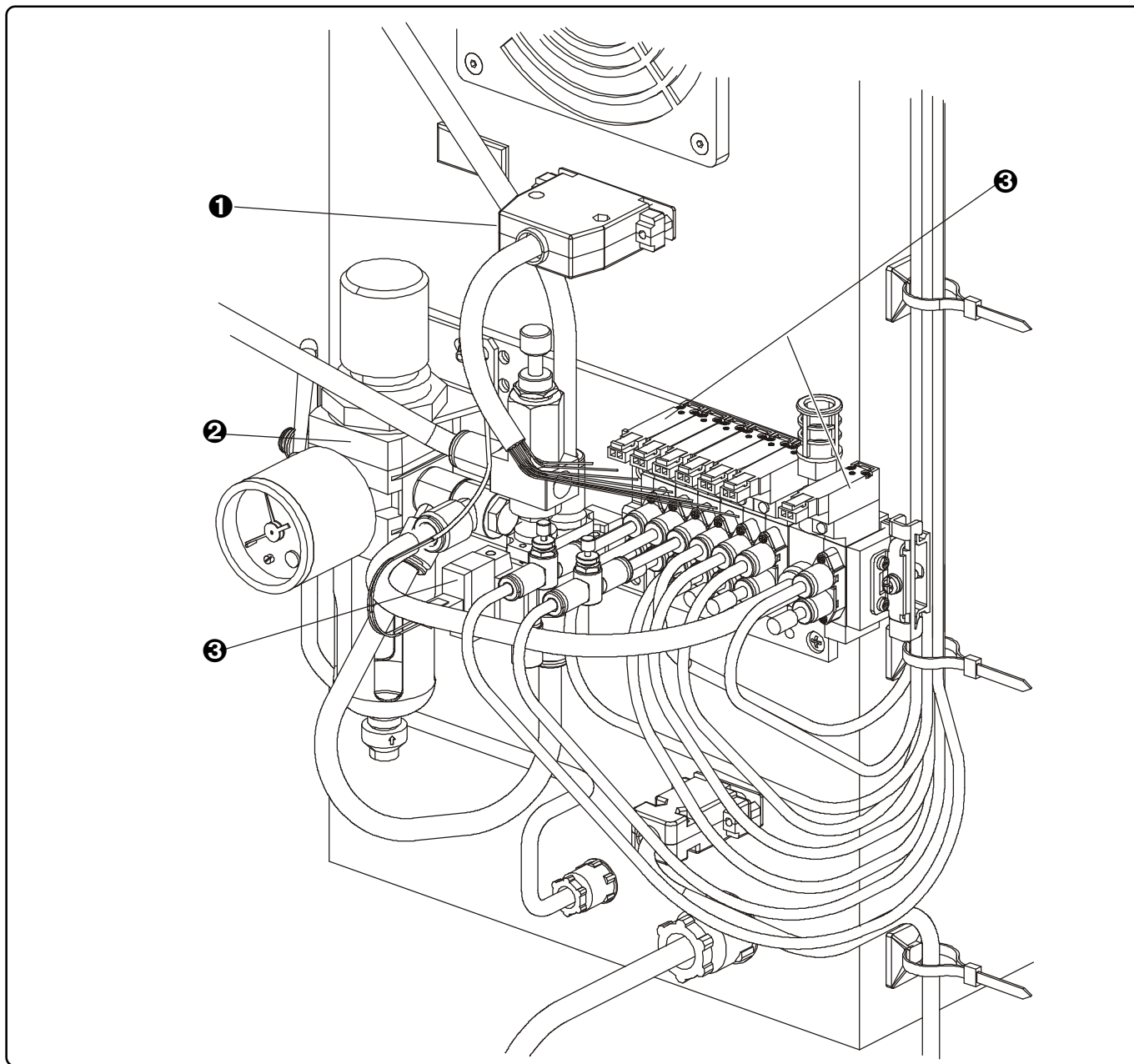

3.2. The machine is connected from the plant. If disassembled, connect the machine as follows:

- blue pneumatic tubes J1A/B — J9A/B connect with equally marked electromagnetic valves.
- cables for stepping motors marked X, Y, R, T connected with equally marked cables.
- remaining cable is used for sensor and switches connection with box.



## B - MACHINE ASSEMBLY

### 4. BELT TENSION

- 4.1. Lower belt **1** of sewing mechanism drive is installed on machine head pulley during the transport. To access this pulley : loosen screw **2** on drive belt cover **4**, shift the cover aside and remove the cover. Then loosen two screws **5** and screw **6** of the drive belt cover **3**.
- 4.2. To remove the cover **4**, loosen the screw **7**. It allows insertion of the panel **3** with the Emergency Stop button, inside the cover.
- 4.3. After loosening the screws **10** of the tension pulley **11**, tighten the belt by moving the pulley. Tighten the screws again.
- 4.4. Check the tension by pressure approximately 10 N above the plate. The deflection of the belt should be approximately 10 mm.
- 4.5. After loosening the screws **14**, it is possible to stretch the upper drive belt **12** using the pulley **13**.
- 4.6. Install the motor pulley cover and machine covers **3**, **4**. By turning the hand wheel **15** check, whether the belts are clear from all covers.

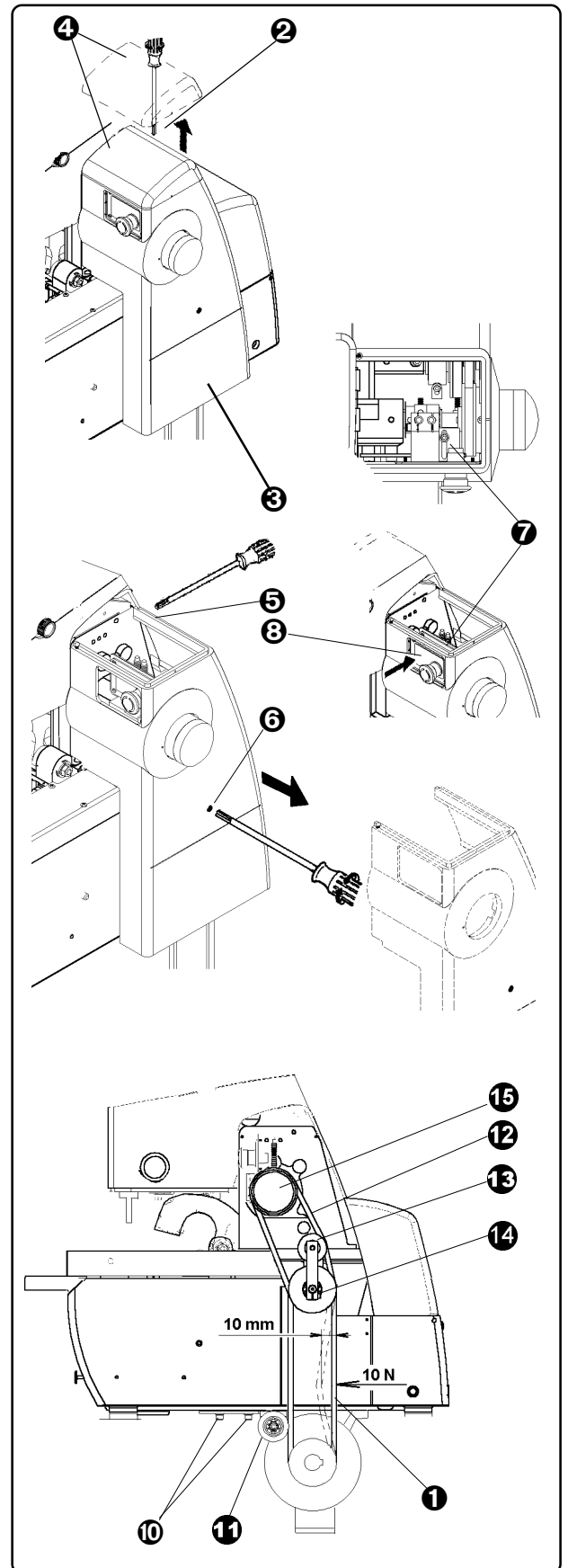

## B - MACHINE ASSEMBLY

### 5. POWER AND AIR CONNECTION

5.1. Simple connection of air lines are made by quick connector. Socket 25 KEAK 13 (order number FESTO 151776 - marking KD 1/4 - S, order number RECTUS 38044) is used as standard. Unithas corresponding input ❶.

Input pressure must minimally be 1 bar (0,1 MPa) greater than output pressure set on regulator. The manufacturer recommends addition of a shut-off valve so that it is possible to close the air supply.

5.2. After air connection check, set the air pressure on the dial of the regulator. It should be in the range 0.45-0.6 MPa. To correct it: pull the stopper ❷ out. To increase the set pressure turn clockwise, to decrease, turn counterclockwise. Tighten the stopper ❷ again. The pressure for the cutting cylinders is set to 0.4 MPa (4bar) from manufacturer by screw ❸ and loosening the nut ❹. If a material is incorrectly cut, check the cutting steel and a pressure on the regulator ❹.

**Note:** Set lower air pressure for short cutting steels and higher air pressure for long cutting steels.

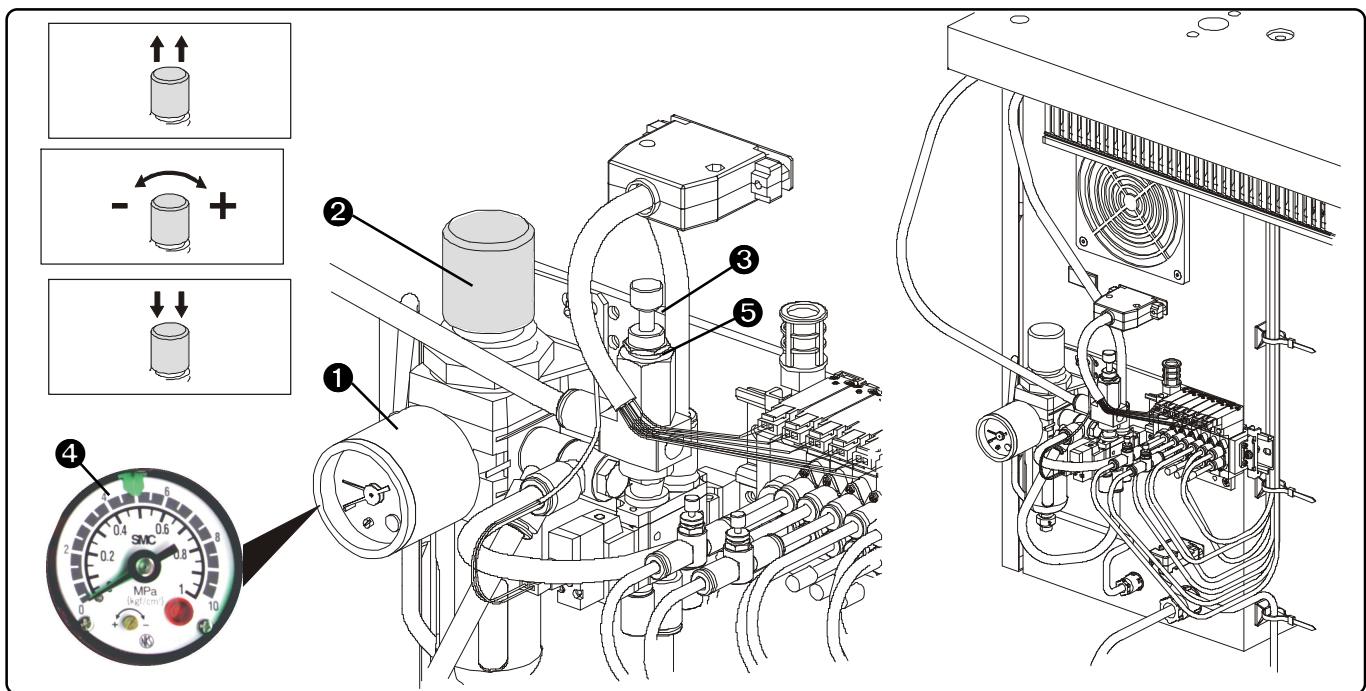

5.3. Power supply must be 208 to 230 volts 1 phase, 50 or 60 hertz. Receptacle plug must meet requirements of IEC standard 364-4-41, its circuit breaker must be minimal 10A with characteristic C according to the EN 60947-2 (or 16A with characteristic B). No other devices must not be connected to the circuit breaker of the socket. The hand wheel ❸ must turn counter clockwise.

*The machine is equipped with a filters which contain capacitors which generate an high frequency leakage current. In order to prevent nuisance tripping, residual current protection device must be protected against these high frequency currents: this is the case for industrial residual current device (example „S“ type).*

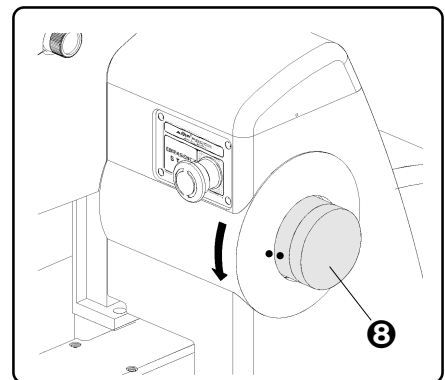

5.4. To add the LED lights - the provided warranty does not refer to the LED diodes.

## B - MACHINE ASSEMBLY

### 6. THREAD STAND INSTALLATION

- 6.1. Put the thread stand together according to the drawing.
- 6.2. Position of the locking ring **1** allows assembly of the thread stand for various thickness of the table top. Threaded end of the post **6** must not extend more than 1 mm through the locking nut **5**.
- 6.3. Insert the washer **2** and the post into the hole provided in the right rear of the table top **3**. Insert the washer **4** and tighten the nut **5**.

Picture 6.1.

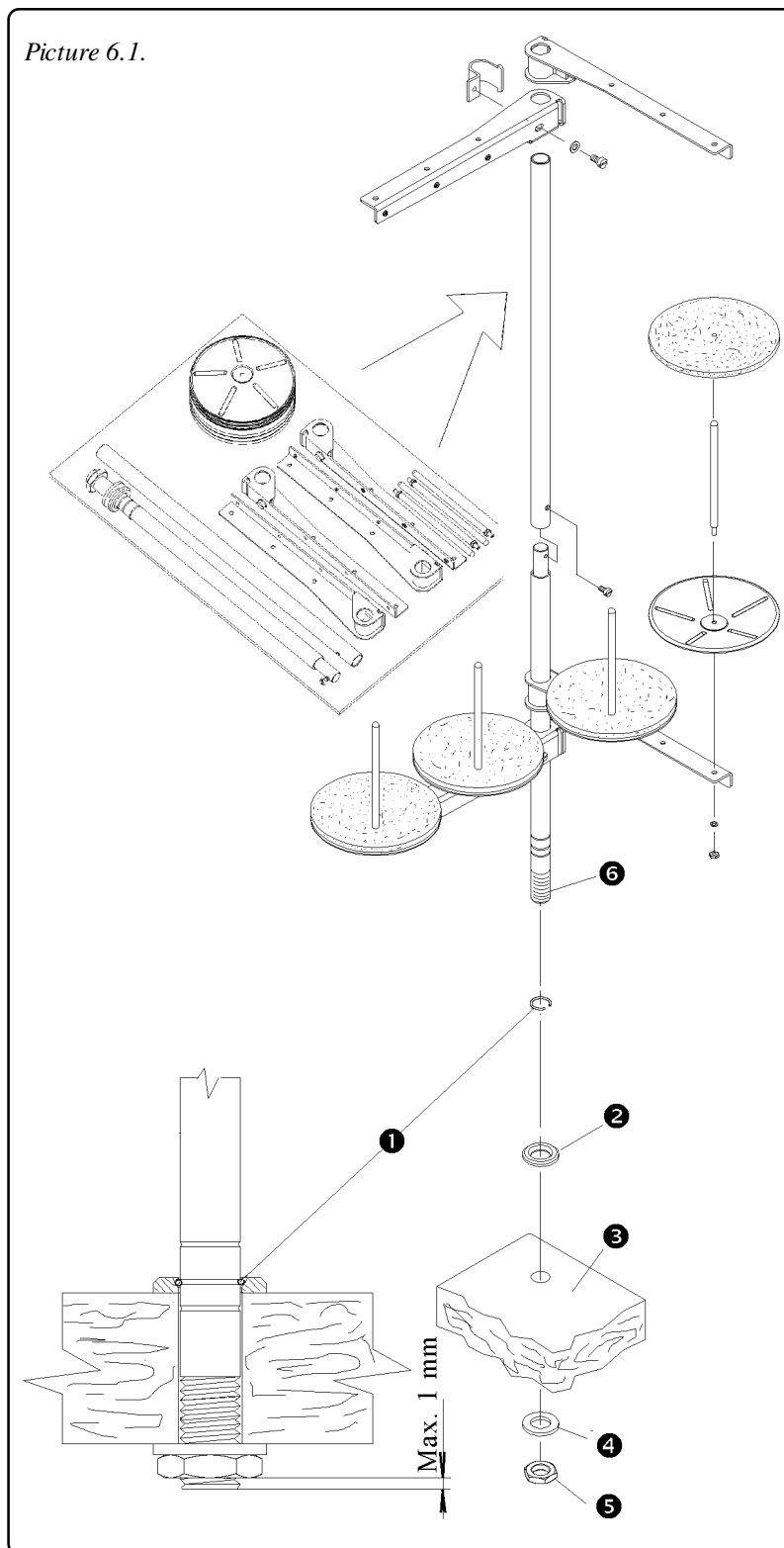

## B - MACHINE ASSEMBLY

### 7. LUBRICATION

- 7.1. There is the tank for oil egress on the machine ❶.
- 7.2. For oil tightness and removal is important, that upper edge of the funnel ❷ inserted to the holder ❸ was on bottom frame area lever ❹ and in holder socket was the rubber ring ❺.

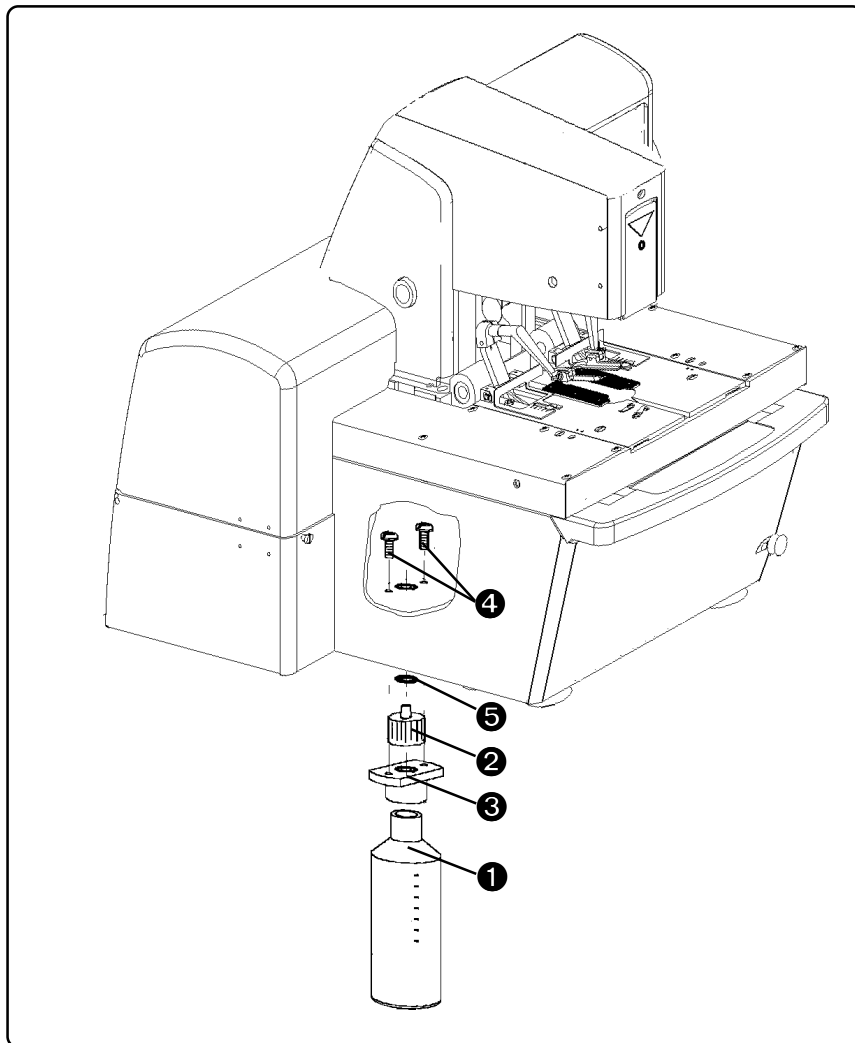

## C - PROPER APPLICATION

### 1. POWER UP / HOME POSITION

- 1.1. Turn the main power switch on ❶ by turning clockwise to the „I“ position.
- 1.2. The display is activated and illuminated. The screen ❷ displays information about manufacturer and version of program installed in the machine. Wait until the main screen ❸ appears on the display.
- 1.3. If the error message **E01** ❹ (machine is not in the home position) appears on the display press the  button ❺. If a different error message appears on the display - follow the Troubleshooting section.
- 1.4. The machine is ready for operation when **Ready** message appears on the display, in location ❹.  
(Display description is on the manual page no. 1-24).

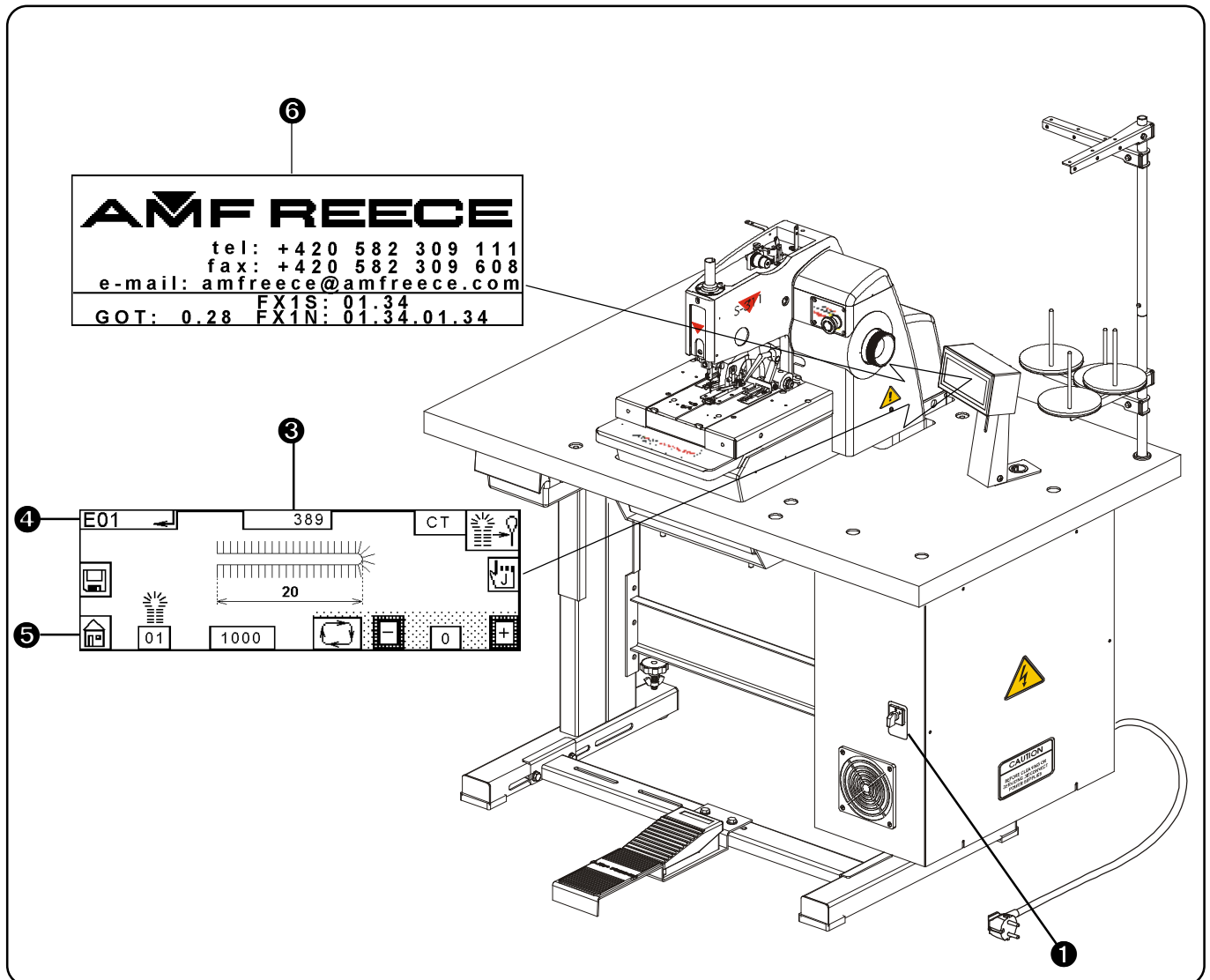

## C - PROPER APPLICATION

### 2. NEEDLE INSTALLATION

Use needles AMF Reece 02.0505.0.111/113.... Nm 90 – 110), loading  $\varnothing$  needle bard D = 2 mm. Needles 02.0558.1.112 are externally treated and needle shape is adapted for sewing thick material. Thicker needles is not possible to use for standard stitching plates.

2.1. Lift the transparent needle cover up ❶.

Recommended Threads No.	Needle System (Nm)
120	90
90	90 – 100
80	90 – 110

2.2. Loosen the screw ❷ and remove the needle.

2.3. Insert the new needle so that the needle scarf **A** is on opposite side from screw ❸ of the tension. Do not install a bent or broken needle. Roll the needle on a flat surface to check for straightness.

2.4. Tighten the screw ❷ well.

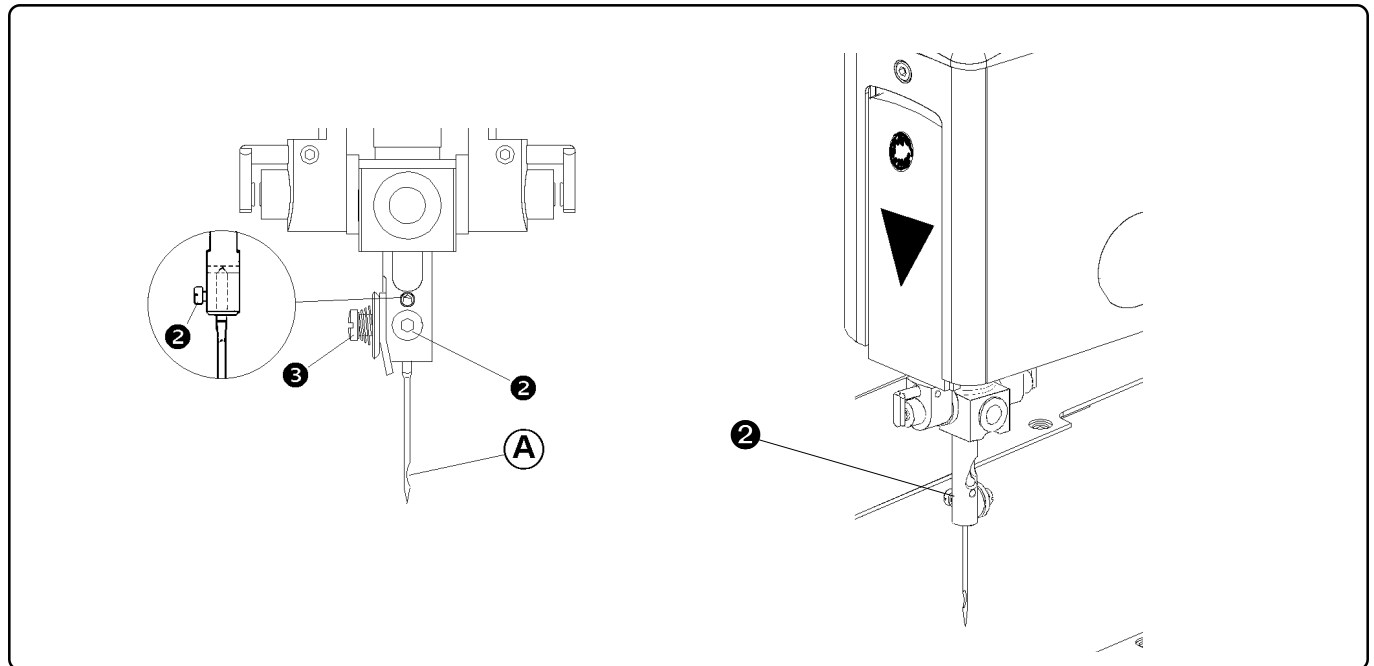
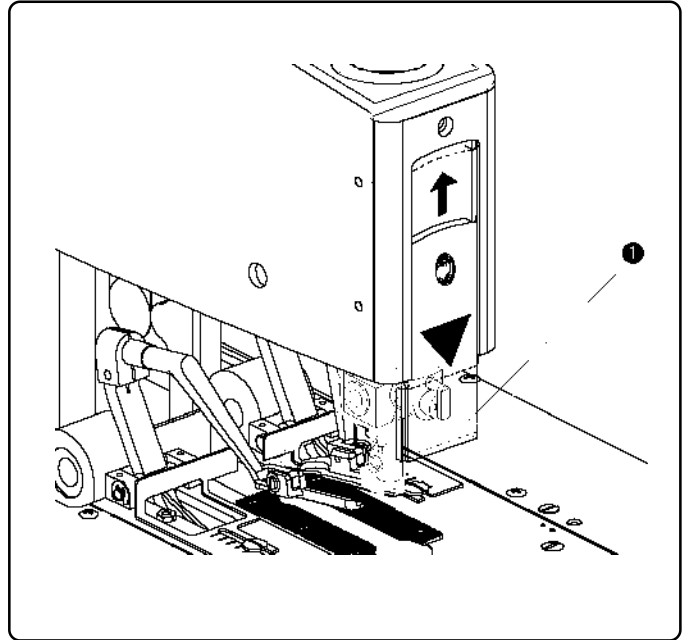

## C - PROPER APPLICATION

### 3. THREADING

When threading, see the pictures below. For easy threading use threading device **1** from accessories kit. It is possible to order the threading device **2**. Adjust the thread tension by knobs **3**, **4** according to sewing conditions.

#### 3.1. Needle thread:

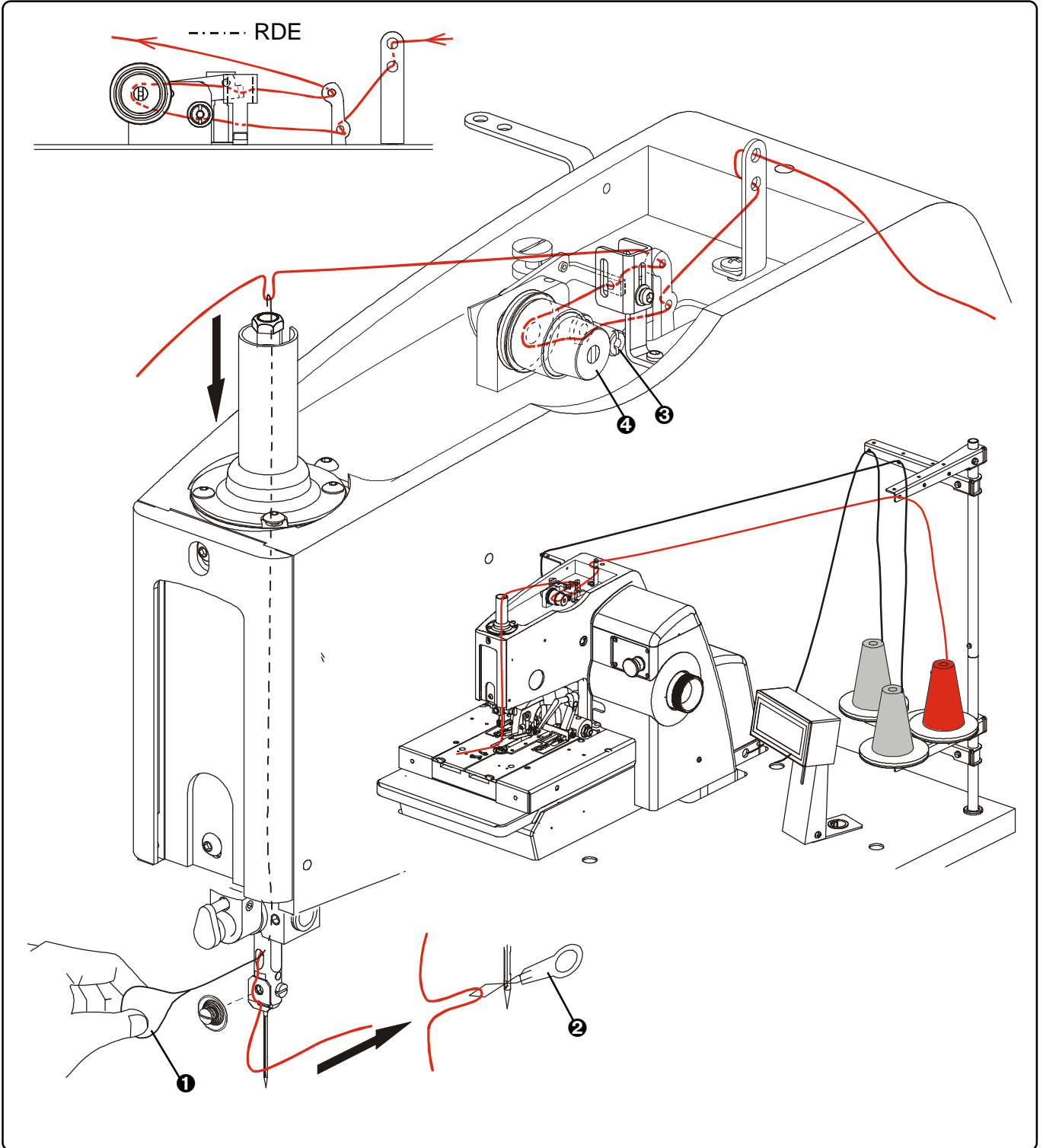

## C - PROPER APPLICATION

### 3.2. Lower thread

- tilt back the rear cover ❶ and lift the machine head ❷ to thread the lower thread.

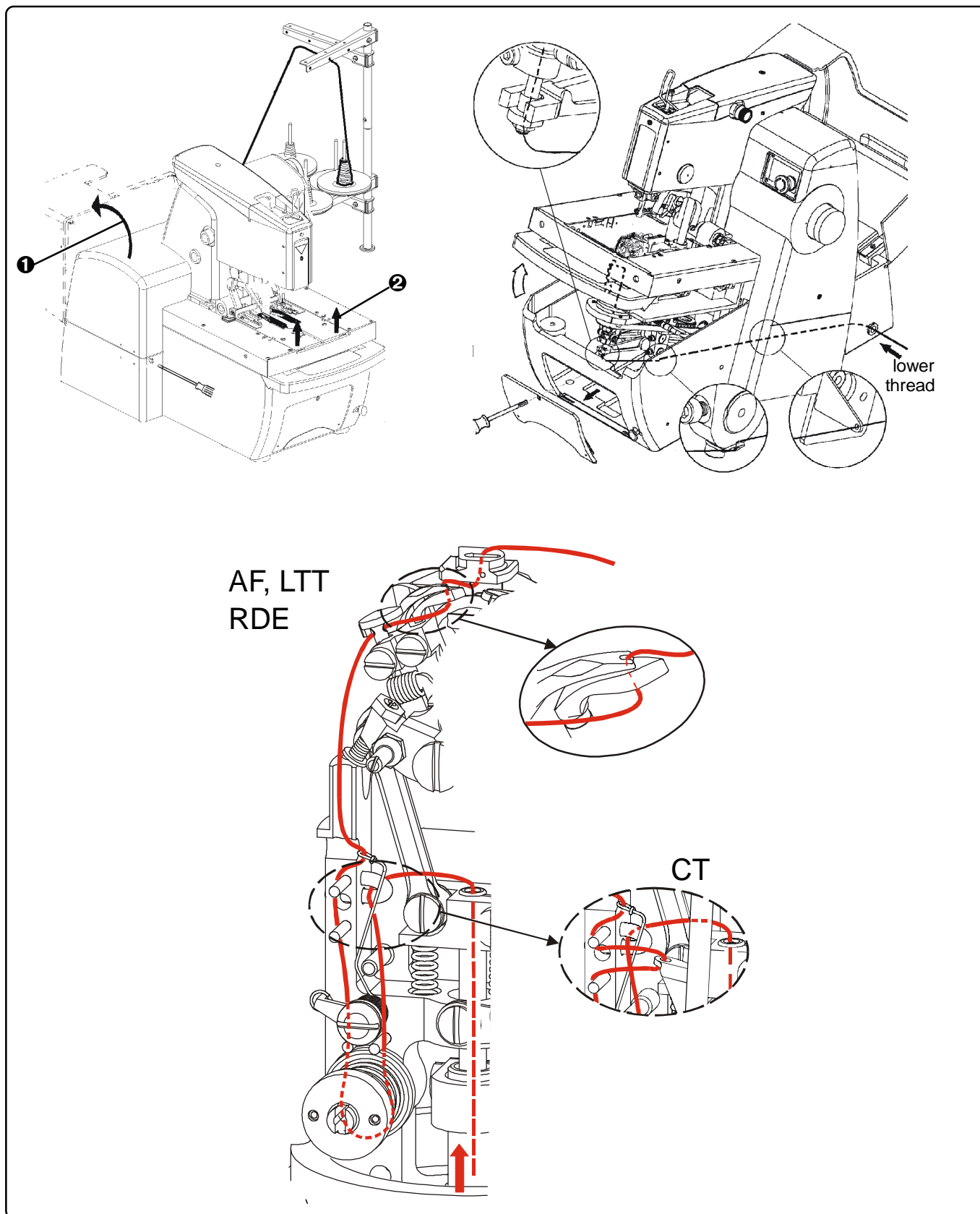



## C - PROPER APPLICATION

### 3.3. Gimp

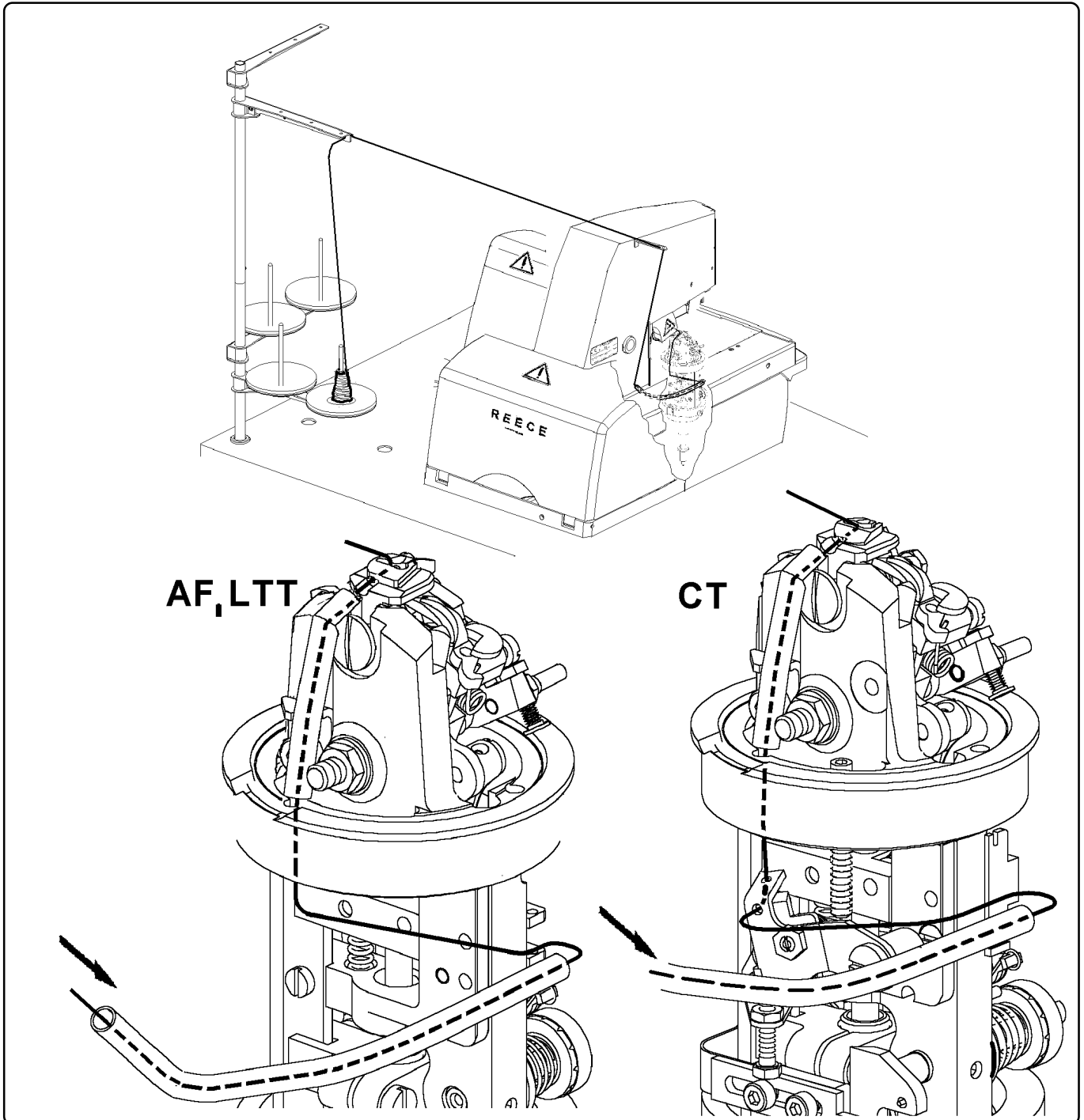

*The appearance and quality of the buttonhole may be affected by one or more of the following:*

- |  |  |
|--|--|
| <ul style="list-style-type: none"> <li>- stitch density ( number of stitches in the first and the second row of stitches)</li> <li>- number of stitches in the eye</li> <li>- amount of fabric spread</li> </ul> | <ul style="list-style-type: none"> <li>- cutting space</li> <li>- tension of upper and lower thread</li> <li>- type of thread (size, etc.)</li> <li>- needle bite</li> <li>- sewn material (thickness, density)</li> </ul> |
|--|--|

## D - MACHINE CONTROLS

### 1. OPERATION

1.1. With the machine in the home position, before sewing, the manufacturer recommends 3 minutes for warm up.

1.2. Be certain that the machine is threaded correctly see section **C3**, and required buttonhole appears on the display. Insert the fabric under the clamp feet. Use the rear stops **❶** to position the buttonhole.

1.3. When the foot pedal **❷** is pressed to the first position, the fabric is clamped by the clamp feet. (When the pedal is released, the clamp feet rise.)

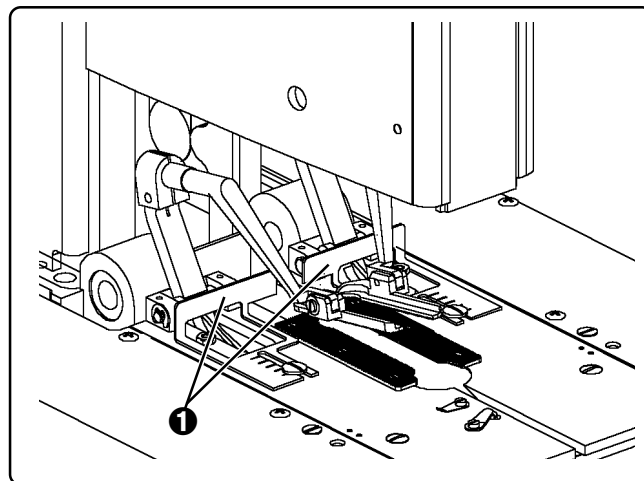

1.4. When the foot pedal is pressed to the its second position, the sewing is started. When the buttonhole is sewn, fabric is cut and the upper thread is trimmed, clamp feet rise and machine returns to its home position.

1.5. When the clamp feet are up, it is possible to move the fabric for sewing the next buttonhole.

1.6. Immediate stopping in any place of the cycle is possible by the EMERGENCY STOP button **❸** on the machine head. If the EMERGENCY STOP is released, the machine stops (the flaw E01, see manual section - troubleshooting).

1.7. If the foot pedal **❷** is pressed before the buttonhole is finished, the clamp feet will not rise. It is possible to sew the buttonhole again after the foot pedal is pressed.

1.8. When your work is finished, switch off the switch **❹**, pull out the plug **❺** from the socket and close the air supply and close the air supply.

## D - MACHINE CONTROLS

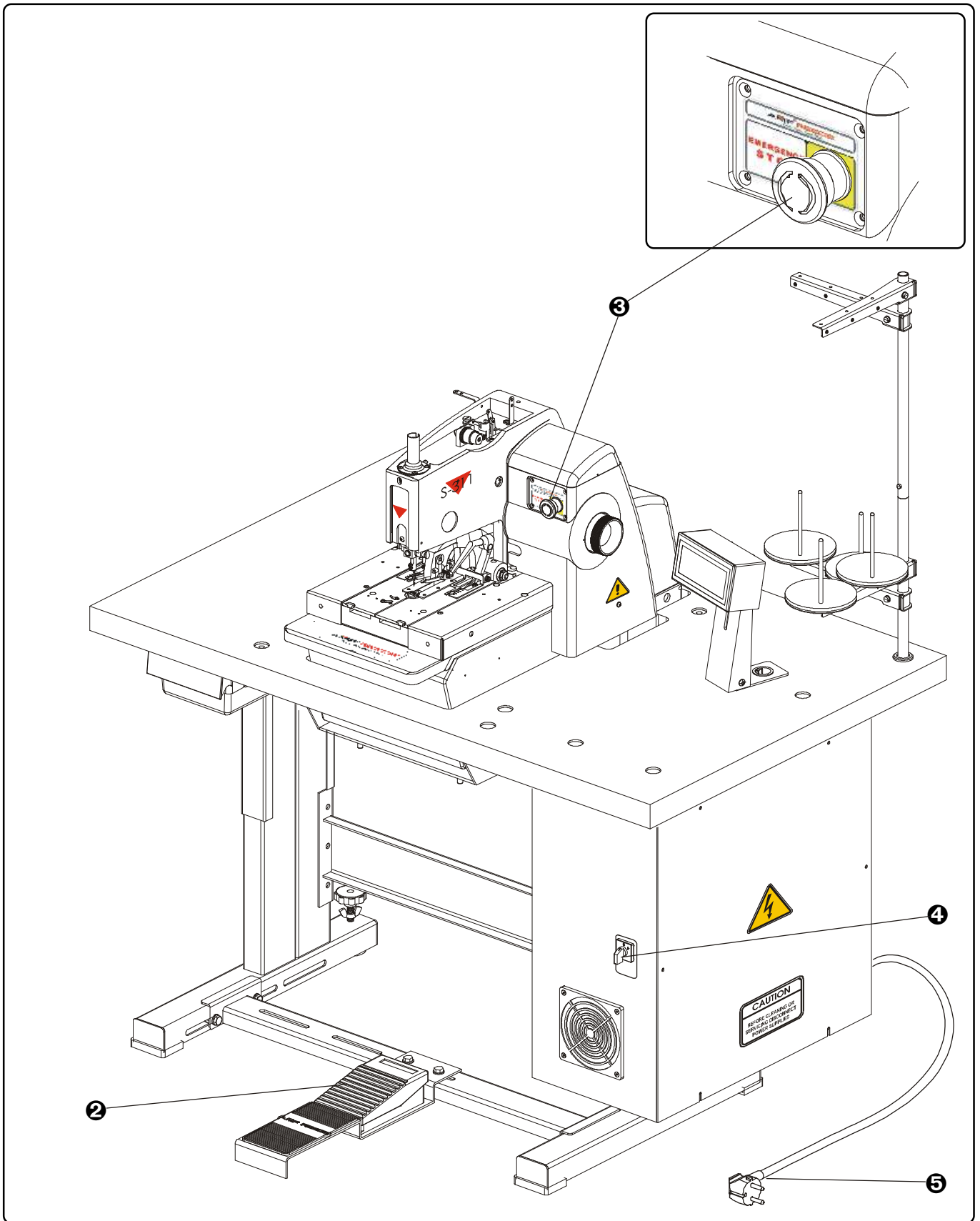

## D - MACHINE CONTROLS

**Caution:** Program for S311 machine is universal, it to sew different buttonholes shapes only with changing the clamp plates. Check, if the clamp plate in machine matches the adjusted machine modification.

Be sure you understand the proper setting of the display: the eye shape, the sewing speed change, machine modification change, the cutting space setting, cycle mode use and button jog use. It is also necessary to understand the proper machine testing. Before setting the display parameters, read the following D section.

### 2. DISPLAY INFORMATION

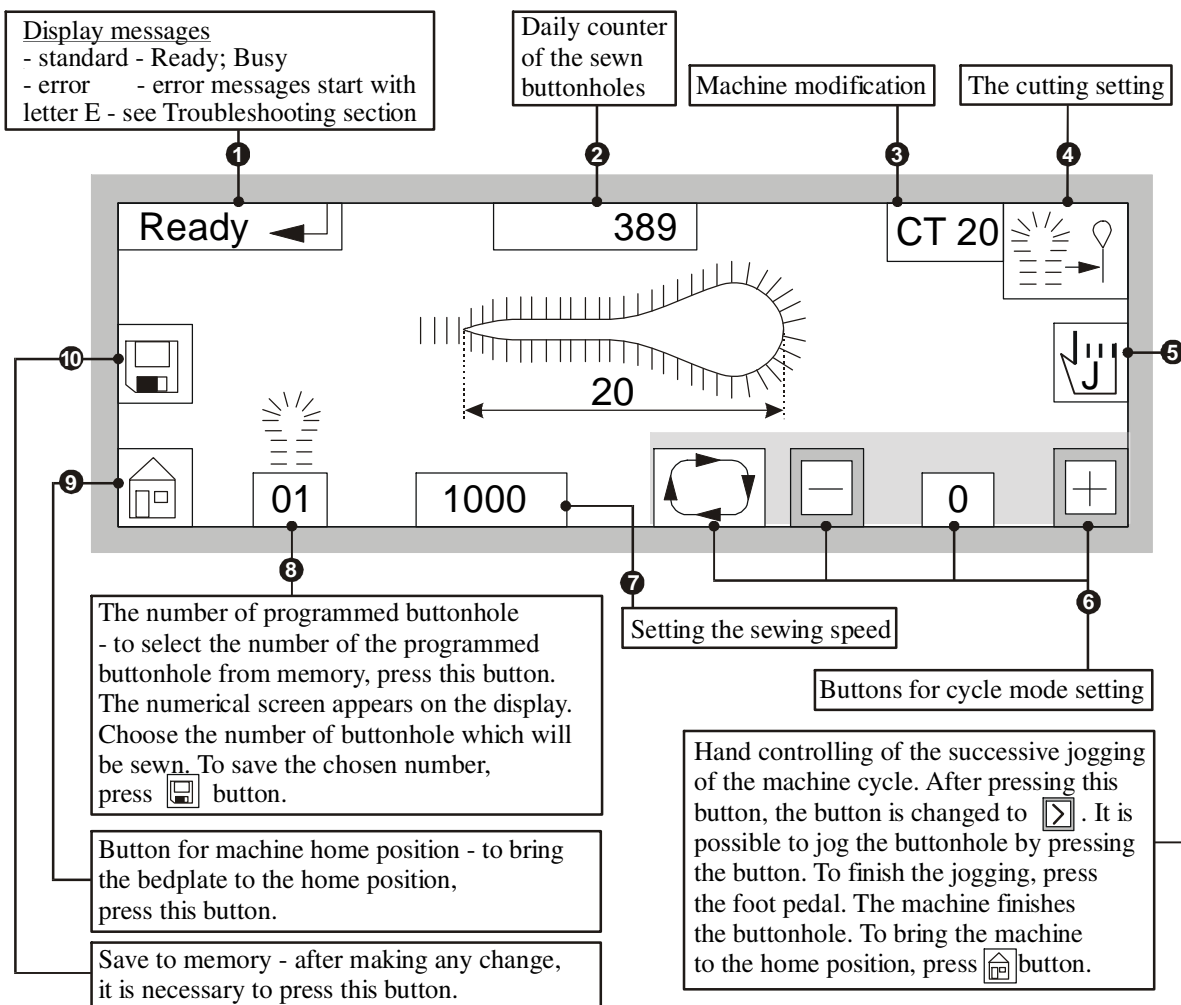

## D - MACHINE CONTROLS

### 3. THE BUTTONHOLE SETTING

To set the buttonhole, it is necessary to set the parameters of eye, the first and the second row of stitches and the bar. For parameters adjustment observe the option sequence **A - B - C** (page 1-25 to 1-27) by pressing it in marked places for the parameter change.

**3.1 - setting the parameters of the eye** - possible sizes of eye: 2,2x3,0; 2,8x4,2; 3,0x4,6; 3,2x5,0; 3,4x4,2; *No Eye or round eye* by pressing surface **A**.

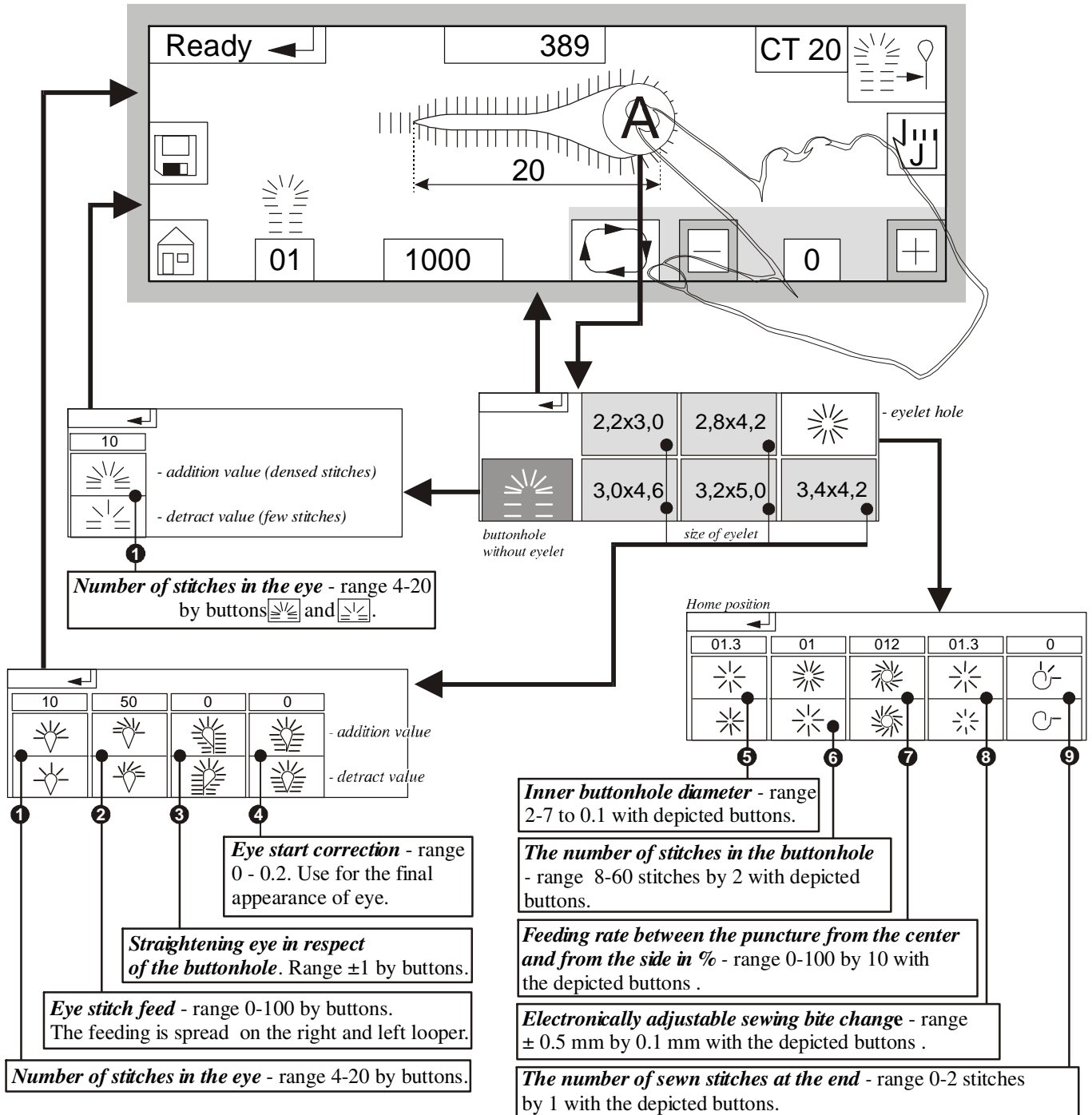

## D - MACHINE CONTROLS

### 3.2 - setting the first and the second row of stitches

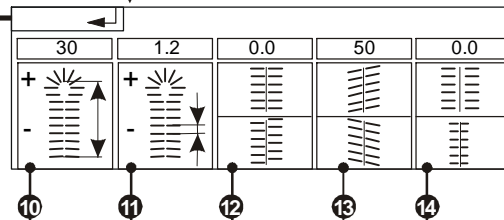
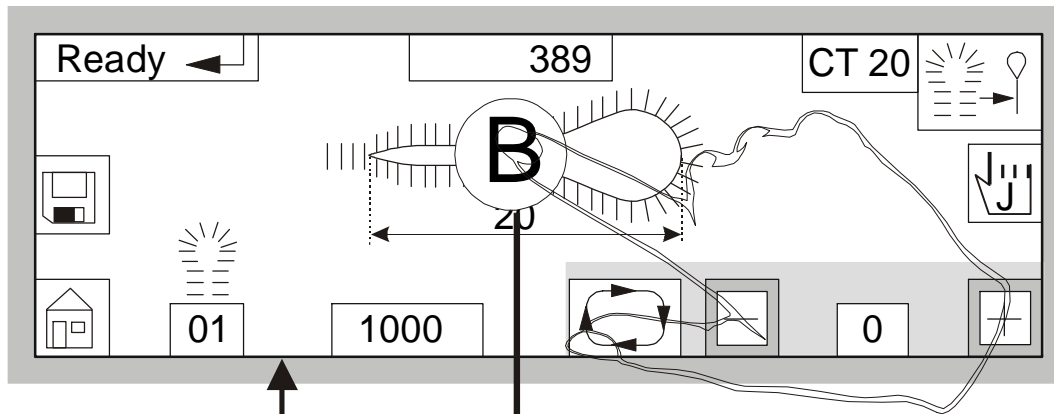

**Length of the buttonhole** -by buttons + and -.

**Stitch density** - range 0,5 - 2,0 mm by buttons + and -.

**The first and the second row of stitches alignment** - range  $\pm 1,5$  mm.  
It is possible to align the second row of stitches against the first row of stitches.

**Stitch angle** - range 0-100 %. If 50% is set, the stitches are vertical to the buttonhole. The feeding is spread on the right and left looper.

**Programmable change of the stitching width** - range -0,3 — +0,3 with buttons.

#### Caution!

If  $\Rightarrow ?$  appears on the display, the total of the length of a buttonhole and the flybar length is exceeded. The length of a buttonhole is automatically set to 23 and length of a flybar to 7.

The S311 CT machine is supplied to sew the buttonholes with flybar. The various clamp feet are supplied with the machine. The length of cutting  $L_1$  is marked on the clamp feet (e.g. 16-20 mm). To trim the lower threads, the length of a buttonhole  $L$  must be set in range 23-27 mm (for clamp feet 16-20 mm). If the upper thread is unthreaded from a needle after trimming the thread, and it is not caught by a thread pick-up, decrease the number of stitches in the flybar by 1 stitch.

Cutting length $L_1$ (mm)		Buttonhole length $L$ (mm)
$L_{1min}$	$L_{1max}$	
16	20	$L_1 + 6 = L$ recommended
20	24	
24	28	
28	32	

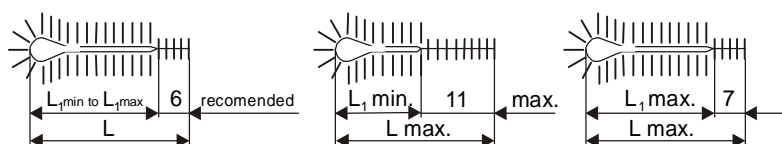

## D - MACHINE CONTROLS

### 3.3 - setting a bar - possible types of the bar: *Open End, Fly Bar, Cross Bar, Round End*

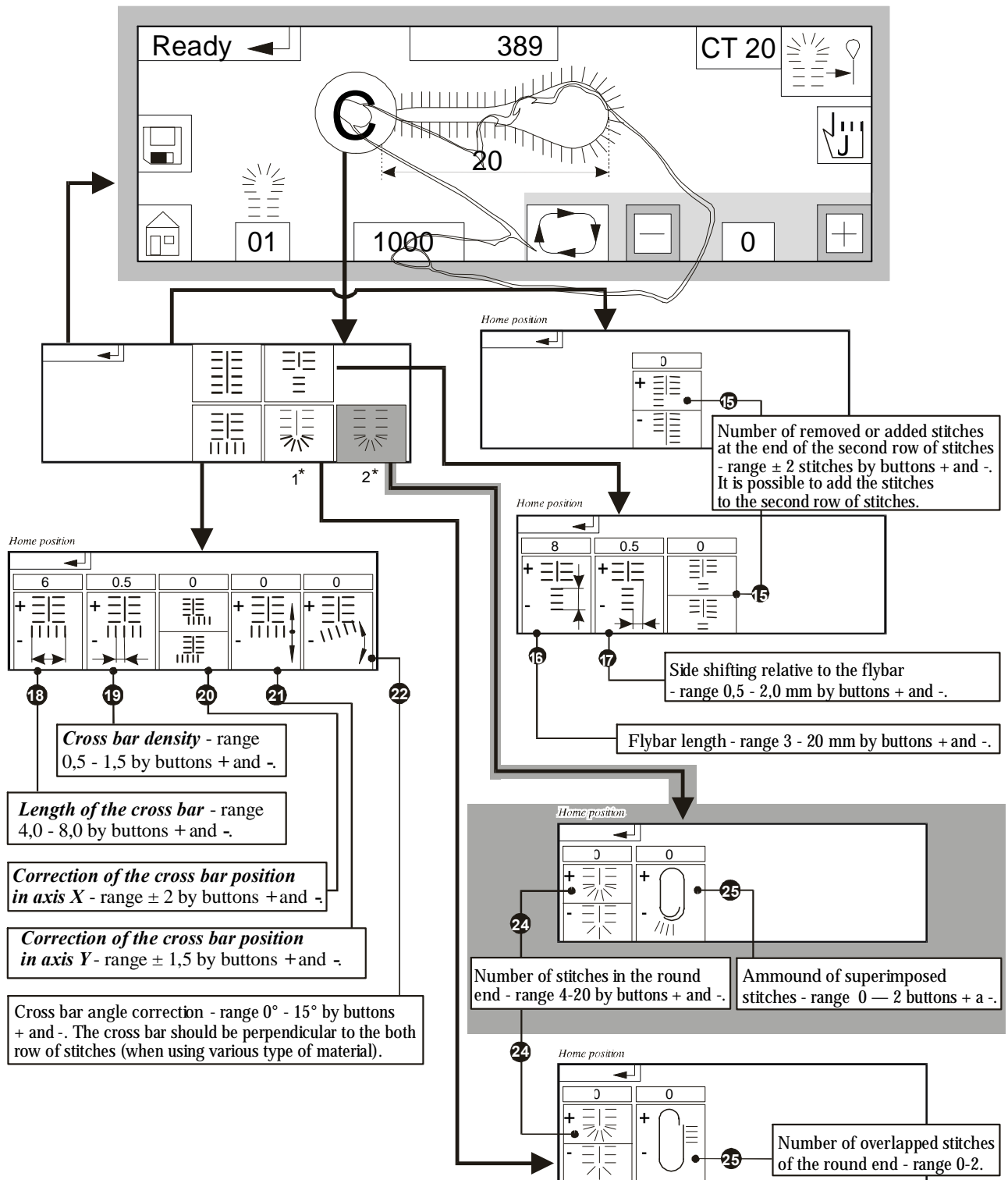

**2\*** For machines S-311 LTT and S-311 LTT/ACL.  
Program: FX1N 00.10 - FX1S 00.11 - GOT 0.00.0.29.

**1\*** For machines S-311 LTT and S-311 LTT/ACL it is not functional.

## D - MACHINE CONTROLS

### 4. THE SEWING SPEED SETTING

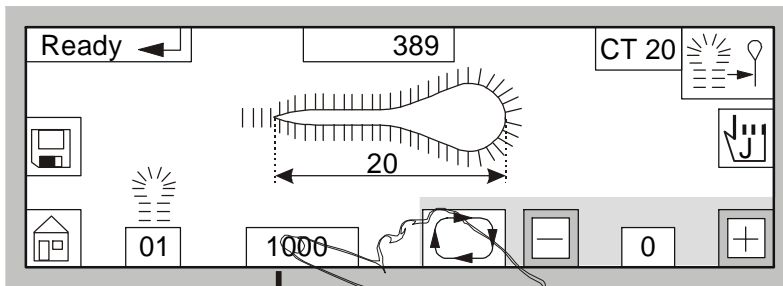

It is possible to set the sewing speed in range 1000, 1300, 1600, 1700, 1800, 1900 and 2000 punctures of needle bar (stitch=two punctures).

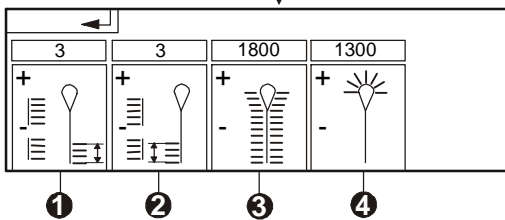

❶ *Number of stitches, which are sewn by slow speed at the beginning of a buttonhole*- range 0-9 by buttons + and -.

❷ *Number of stitches, which are sewn by slow speed at the end of a buttonhole*- range 0-9 by buttons + and -.

❸ *Sewing speed in the first and the second row of stitches* - range 1000 - 2000 by buttons + and - .

❹ *Sewing speed in the eye* - range 1000 - 2000 by buttons + and - .

**Note:** For **RDE** version is not the button ❶ functional and we do not recommend to use buttons ❷ ❹. Control the sewing with button ❸.

### 5. PARAMETERS SAVING

1. *To save the set parameters to the same assigned number of a buttonhole ❶*, press button ❷.

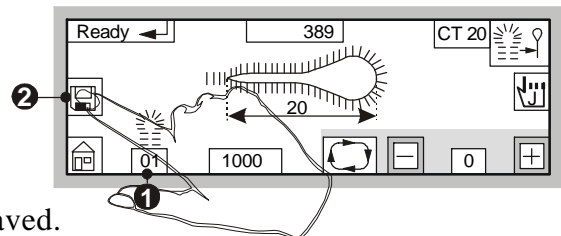

This  appears on the display and parameters are saved.

2. *To save the set parameters to a new number of a buttonhole:* press the number of a buttonhole button ❶.

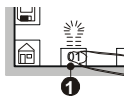

The numerical display appears on the display.

Choose the number and press the button ❸.

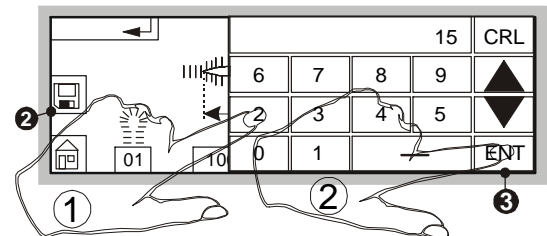

The number of buttonhole ❶ appears on the display.

Press button ❷, to save set parameters.

This  appears on the display and parameters are saved.

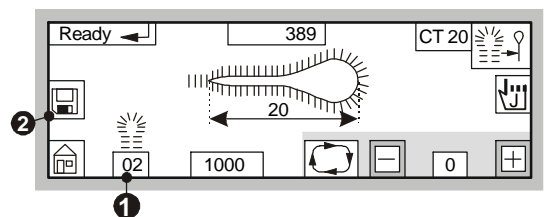



## D - MACHINE CONTROLS

### 6. COPYING ADJUSTED PARAMETERS UNDER NEW NUMBER

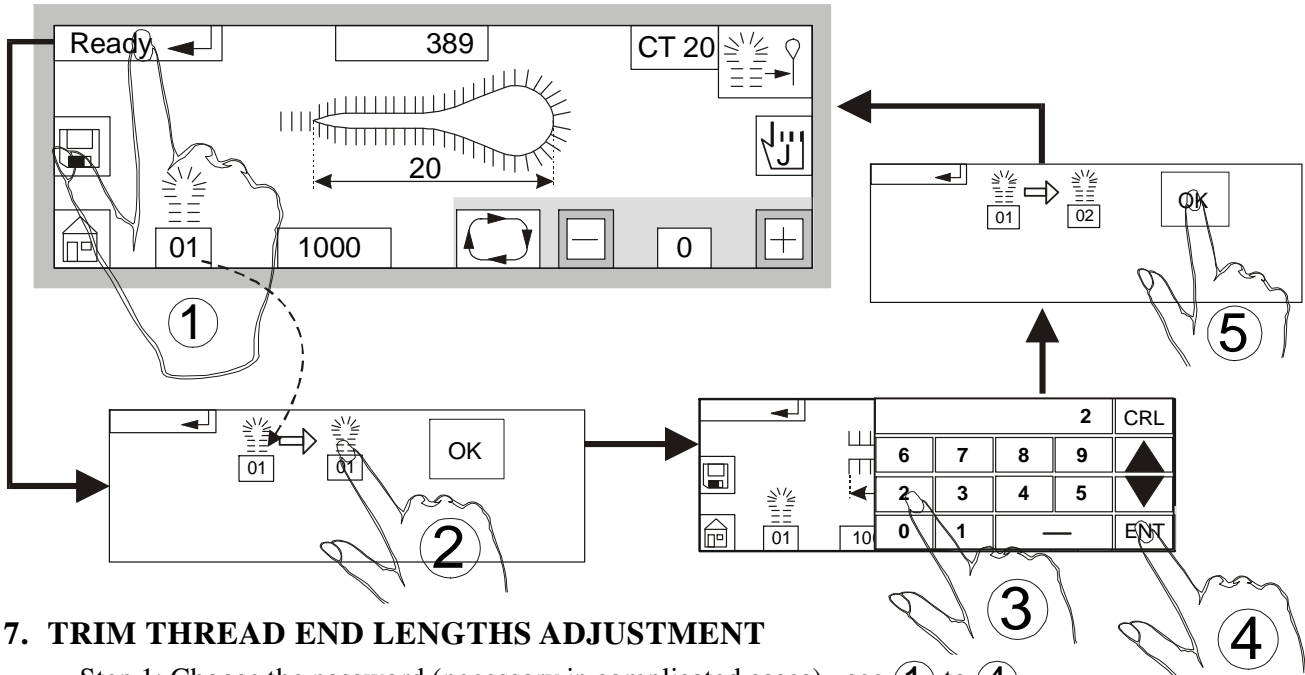

### 7. TRIM THREAD END LENGTHS ADJUSTMENT

Step 1: Choose the password (necessary in complicated cases) - see ① to ④.

Step 2: Set the length tails of trimmed thread - see ⑤ to ⑥.

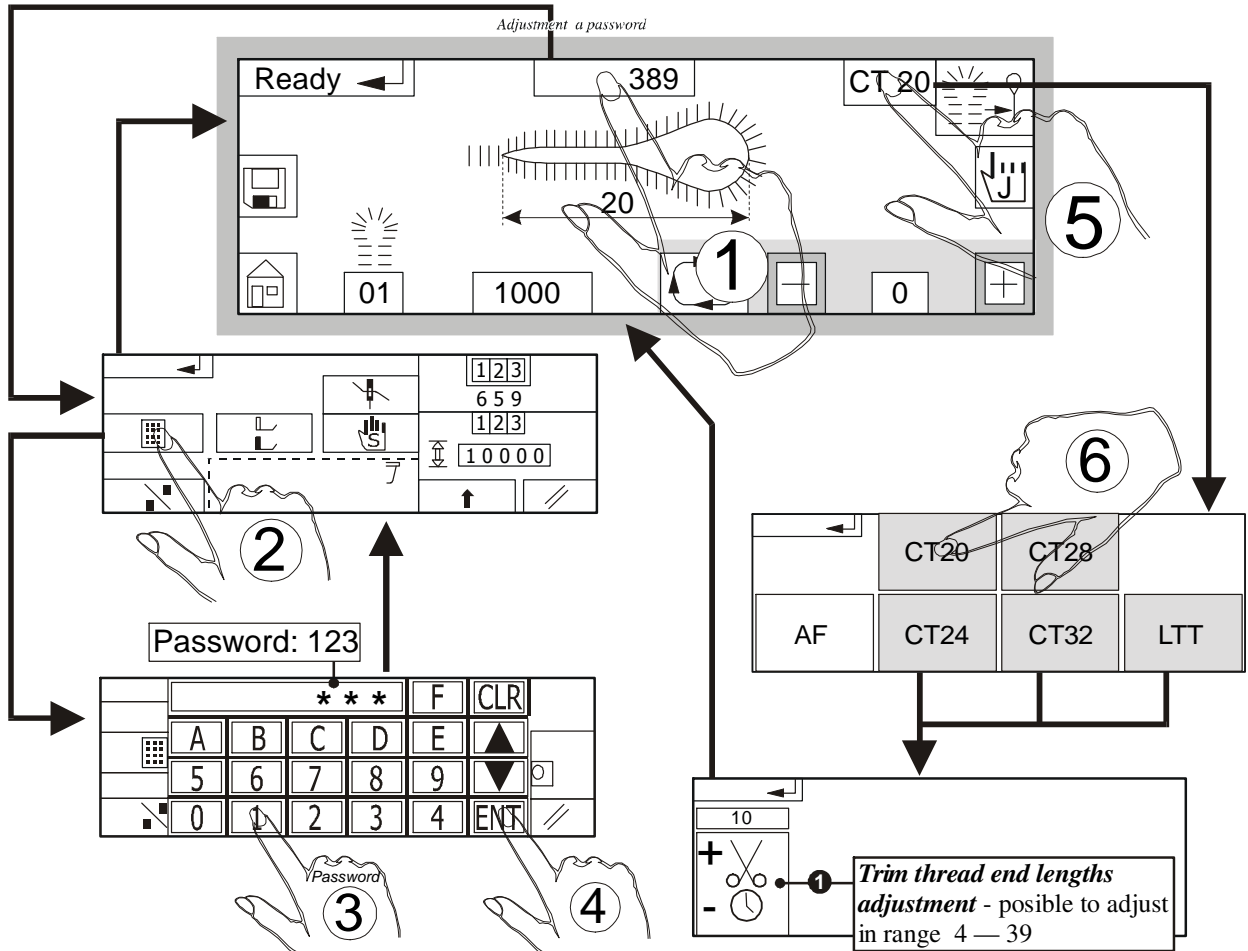

## D - MACHINE CONTROLS

### 8. SETTING THE CUTTING

Press button  to set the cutting.

Possible setting:

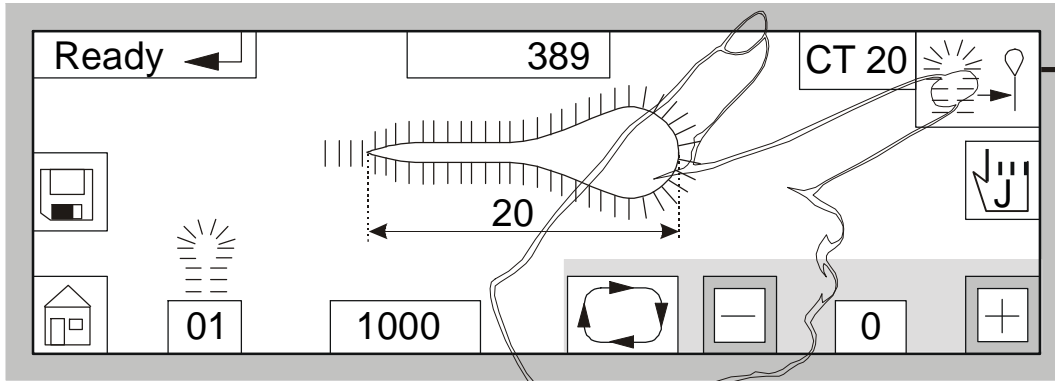

- Cut before sewing the buttonhole (CB)
- Cut after sewing the buttonhole (CA)
- No cut

**Modification RDE not function button**

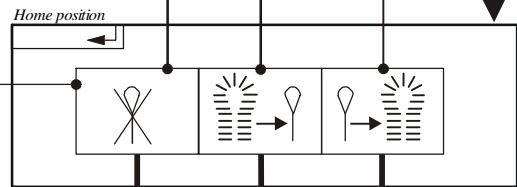
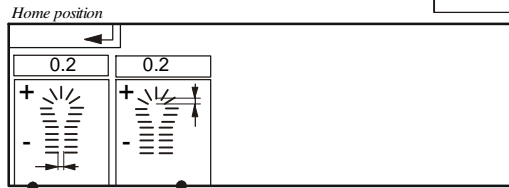

**Cutting space** - range from -0,5 to +1,2 mm by buttons + and -. Choose required value. Negative values are usually used for sewing with CB.

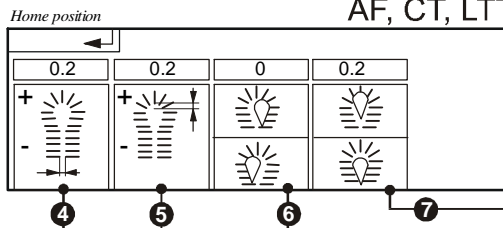

**Centering the knife cut (axis Y)** - range  $\pm 1,5$  mm.

**Stitches distance from cut to inner stitches of the eye** - range from -0,5 to +1,2 mm by buttons + and -. Choose required value. Negative values are usually used for sewing with CB.

**Centering the knife cut (axis X)** - range  $\pm 1,5$  mm. To move the knife to the left, choose negative value, to move the knife to the right, choose positive value.

#### Cutting the round eyelet:

a) adjustment buttonhole eyelet

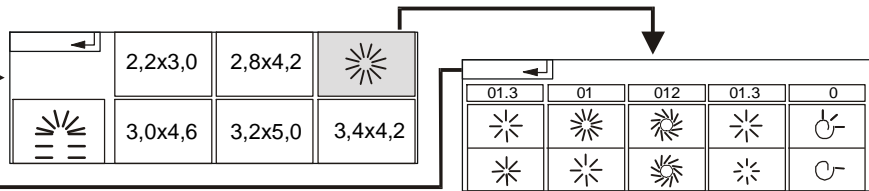
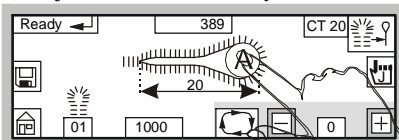

b) cutting the buttonhole eyelet

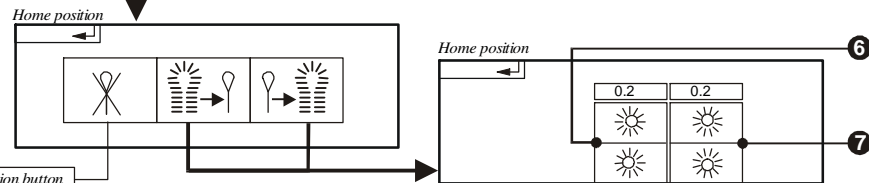
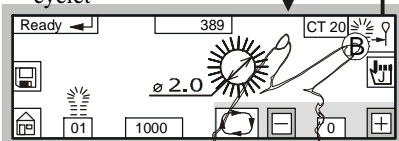

**Modification RDE not function button**

## D - MACHINE CONTROLS

### 9. SERVICE MODE

Determined for mechanics - machine adjustment.

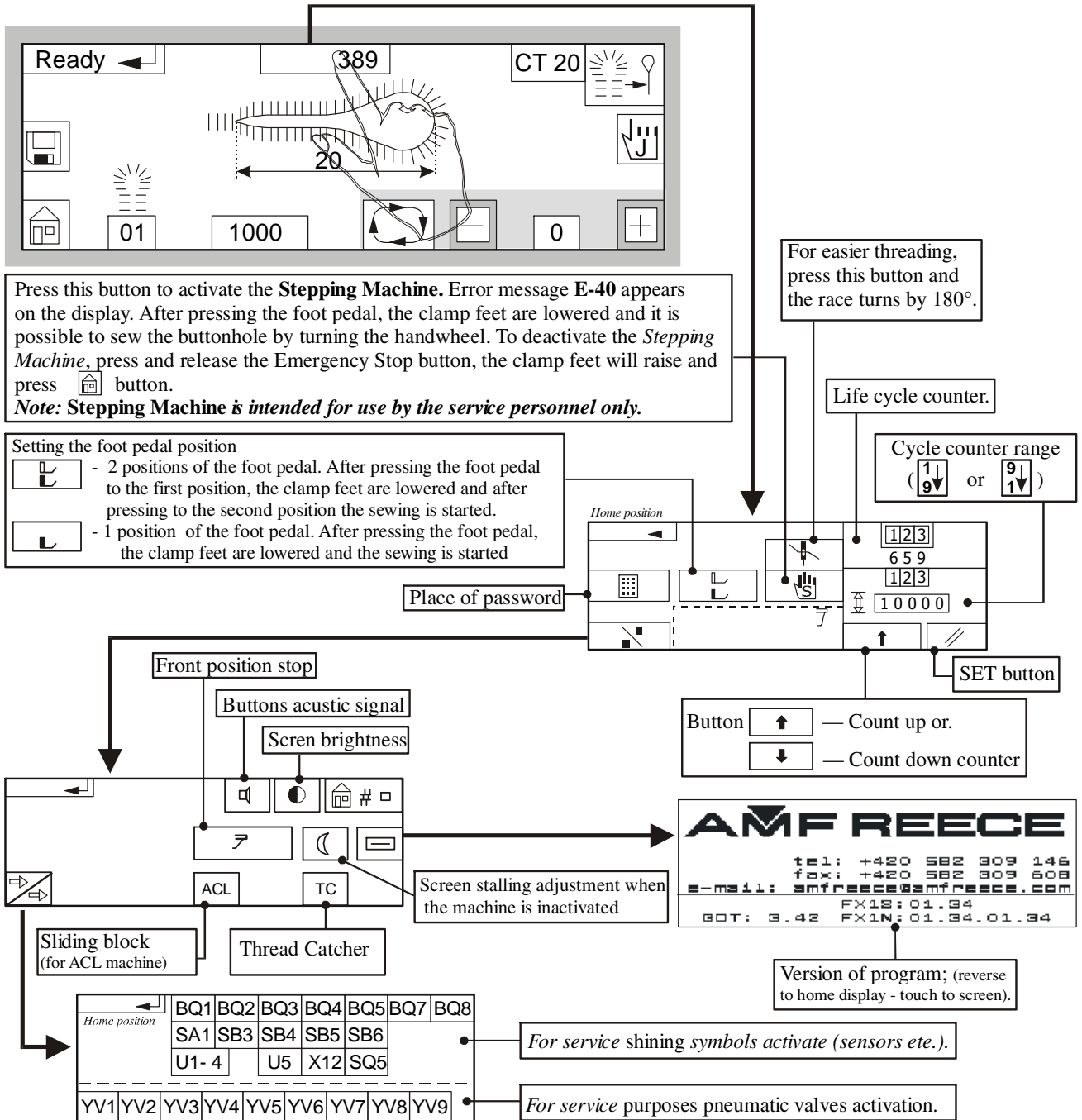

**Cycle counter** - Possible setting:

- ascending counting** - to ascend the buttonholes, set the value of the cycle counter range , set button and press button
- descending counting** - to descend the buttonholes, set the value of the cycle counter range , set button and press button.

## D - MACHINE CONTROLS

### 10. CYCLE MODE

It is possible to set the type and the number of buttonholes which will be sewn in one sewing cycle.

#### CAUTION:

Modification **AF** - it is necessary to use the same cutting length for all buttonholes in one cycle. Imitation (no cut) buttonholes of different length can be included in the sewing cycle.

Modification **CT** - to prevent the machine from damage, the length of buttonholes in one cycle must be the same as the length of a cutting steel in the machine. To trim the lower threads, set the length of a buttonhole according to the installed clamp feet - see section **D3**.

**Veškeré naprogramované dírky a programy - zapsat, zapamatovat!!!**

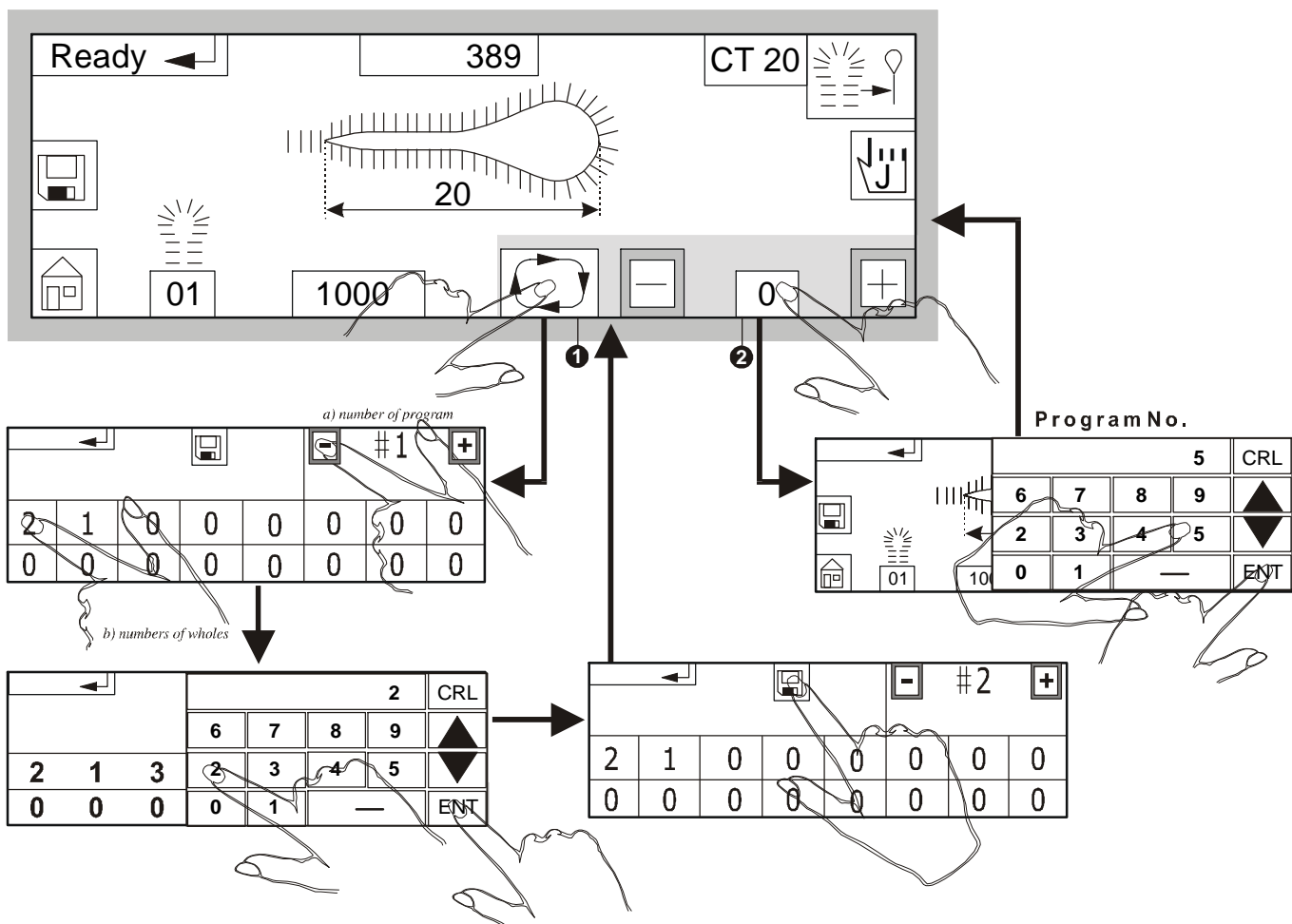

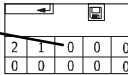
- ① **Setting the number of buttonholes in the cycle** - possible setting: 1-16 buttonholes  
*Note:* If 0  is set, the machine starts to sew from the first set buttonhole.

- ② **Program number setting** - range 0-9. If 0 (②) is set, the cycle mode is not activated. After the machine is switched on, the 0 automatically appears in the program number.

## D - MACHINE CONTROLS

### Example:

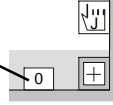

In the program number **5** you want to sew the buttonholes in the following order: **2, 1, 3, 4, 1**.

1. To set the program number press the button



The numerical display appears on the screen. Choose program number **5** and press ENT.

2. Press  button. The screen, where it is possible to set the order of sewn buttonholes, appears on the display. Press the first number and using the numerical display set the buttonhole number **2**, which will be sewn as the first. Press ENT to confirm. Next, press the second number to set the buttonhole number **1**. Follow these steps to set all the buttonholes which will be sewn. If **0** is selected, the cycle mode will return to the first set buttonhole (**2**).

3. Press  to save the set buttonholes to program number **5**. Return to the main screen .

4. Program number **5** and buttonhole number **2** appear on the display.

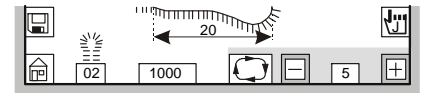

5. When the buttonhole is sewn, the number of the next buttonhole in the cycle (**1**) will be displayed.

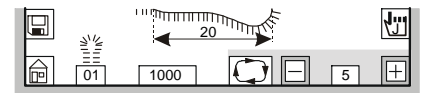

## 11. THE ELECTRONIC SYSTEM ERROR MESSAGES

If an error message appears on the display, press it **①**. The screen **②** with a description and a correction of an error message appears on the display (see Troubleshooting).

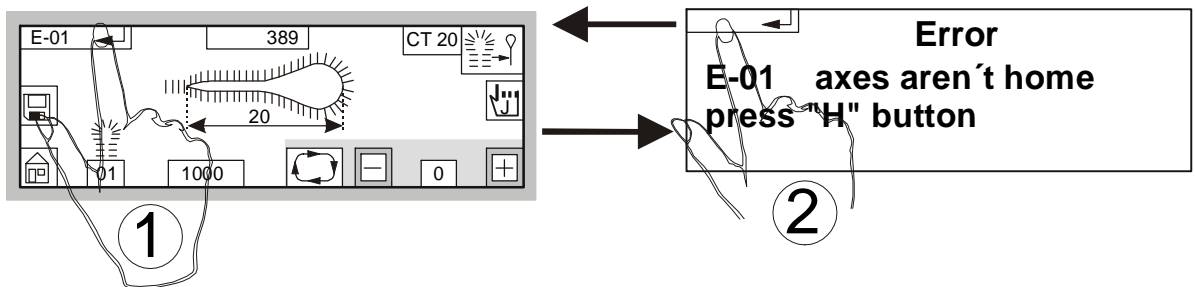

## 12. MANUAL CUT MODE

The green button **①** outside of the control box, activates cutting independently of the program. It may be used with or without the fabric clamps (closed by pressing the foot pedal to the first position).

**Progress:** Insert the fabric under the clamp feet, switch the foot pedal into the first position, hold this pedal in this position and press button **①**. Cutting lever will cut the fabric everytime, when the button **①** is pressed. Then release the foot pedal.

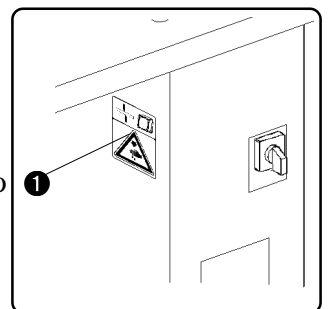

## E - STANDARD MACHINE ADJUSTMENT

**Warning:** - before making any adjustments, turn the main power switch off  
 - careless adjustment can cause damage to electronic and mechanical parts

**Caution:** - always maintain good safety standards  
 - where possible, remove the sewing needle before making mechanical adjustments

### 1. STANDARD BUTTONHOLE SHAPES SET BY THE MANUFACTURER

There are two types of zero buttonhole preset in the program, one type with eye and fly bar for AF, CT, LTT modifications and second type of round eye for RDE modification according to the following overview. It is possible to use the universal program, which allows, after clamp plates and necessary parts replacement, programming of all advertised buttonhole types, by changing zero buttonhole. Rear thoroughly the section "D" for adjustment - machine function control..

**Warning:** Check every time the number of program is changed, if the needed buttonhole shape is selected properly.

Section	AF, CT, LTT	RDE	Section	AF, CT, LTT	RDE	Section	AF, CT, LTT	RDE	
D2	③ AF		D3.2	⑪ 1.2		D3.3	⑳ 4		
D6	② CA			⑫ 0				0	
D3.1	3,2x5,0			⑬ 50				⑫ 0	
	① 9			⑭ 0		D4	① 0		
	② 50		D3.3	0			② 0		
	③ 0			0			③ 2000		
	④ 0		⑮ 0		④ 2000				
		⑤ 2		⑯ 1.6		D7	① 4		
		⑥ 16		⑰ 5		D8	④ 0		
		⑦ 50		⑱ 0.8			⑤ 0		
	⑧ 0		⑳ 0		⑥ 0		0		
	⑨ 1		㉑ 0		⑦ 0	0			
D3.2	⑩ 16		㉒ 0						

## E - STANDARD MACHINE ADJUSTMENT

### 2. THE SEWING DRIVE SENSOR PLATES ADJUSTMENT

It is important that the sensor plates of the sewing drive are properly adjusted. To access these plates, remove the right side cover according to the section B4. The sensors are adjusted from the manufacturing factory and are marked with the colour.

BQ8 - The sensor for needle bar position when the machine is stopped.

BQ1 - The sensor for table feeding when sewing.

- 2.1. Rotate the hand wheel ⑦ until the marking is on the top.
- 2.2. Then rotate the hand wheel again for approximately 90° (picture 2), the needle bar lifts for 2mm in front of the top position. At this moment, rotate the plate ③ of the sensor ② the way until the sensor is activated (diode on the sensor shines), tighten the screw ⑤.
- 2.3. Adjust approximately the plate ④ after loosening the screws ⑥ the way, so its screw was in the plate tooth ③ level. Rotate the hand wheel and adjust the needle bar into the bottom position. Adjust the plate ④ position so the sensor ① is activated. Tighten the screws ⑤, ⑥ and put coating on it.

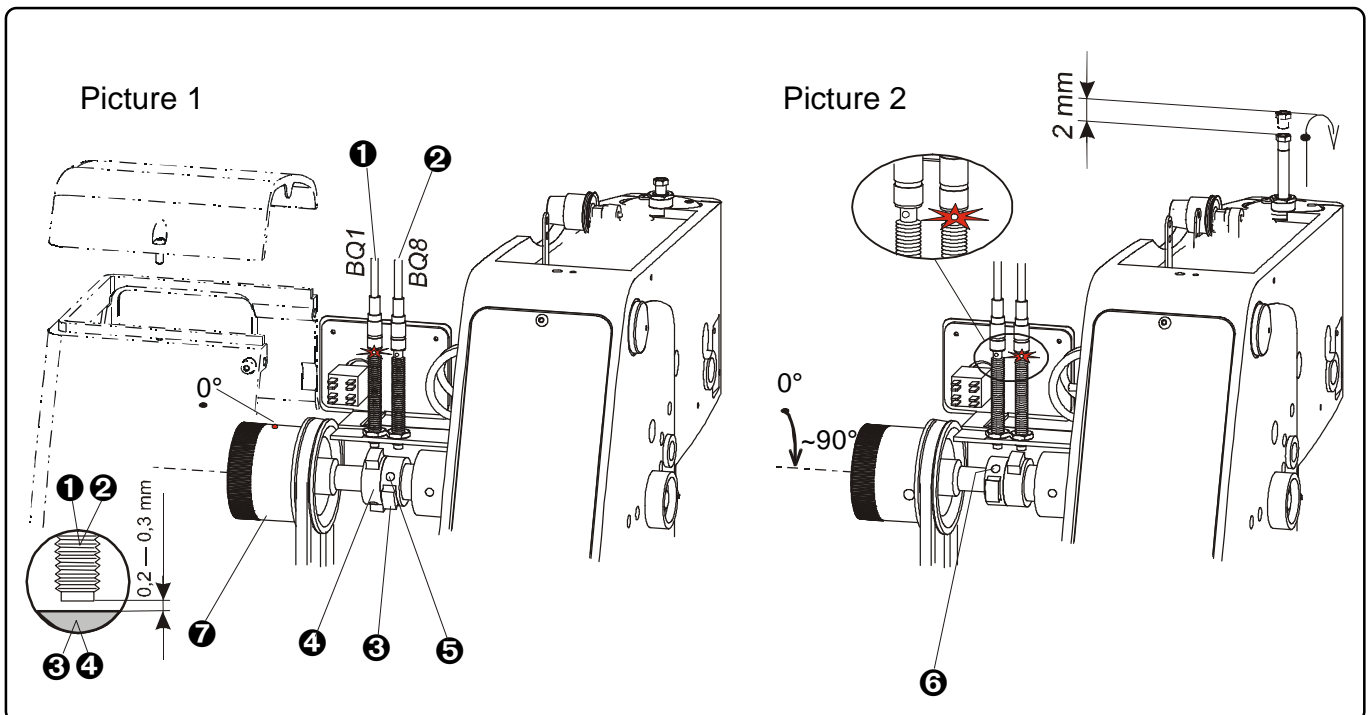

## E - STANDARD MACHINE ADJUSTMENT

### 3. THE BEDPLATE HOME POSITION ADJUSTMENT

The bedplate home position is given by position of the plates **4,7** and sensor BQ2 **8** for axes X and BQ3 **5** for Y. Sensor plate screws are painted from the manufacturer, and only a service technician from AMF REECE can perform this operation during the guarantee period.

- 3.1. Adjust the sensor plate **4** (BQ2) **8** after loosening the screws, **5** to approximately 14 mm. Remove the right cover of the bedplate **9** to access to the plate **4**.
- 3.2. After removing the left cover of the table **1** adjust the sensor (BQ3) **5**. Loosen the screws **6** to obtain the  $129 \pm 0.2$  mm from the shaft holder **2** to the plate edge - see picture. Belt holder is set to 138 mm from the shaft holder **2**. The plate **7** should be 32mm long.
- 3.3. The clearance between the sensor and plate must be 0.2 - 0.3mm. More clearance causes improper sensor function.
- 3.4. Adjust the position of the sensor plate **7** if the dimension from inner puncture in the eye top and the centre needle is not 64mm. Approximately 154mm from the edge of the bedplate, see section E8).

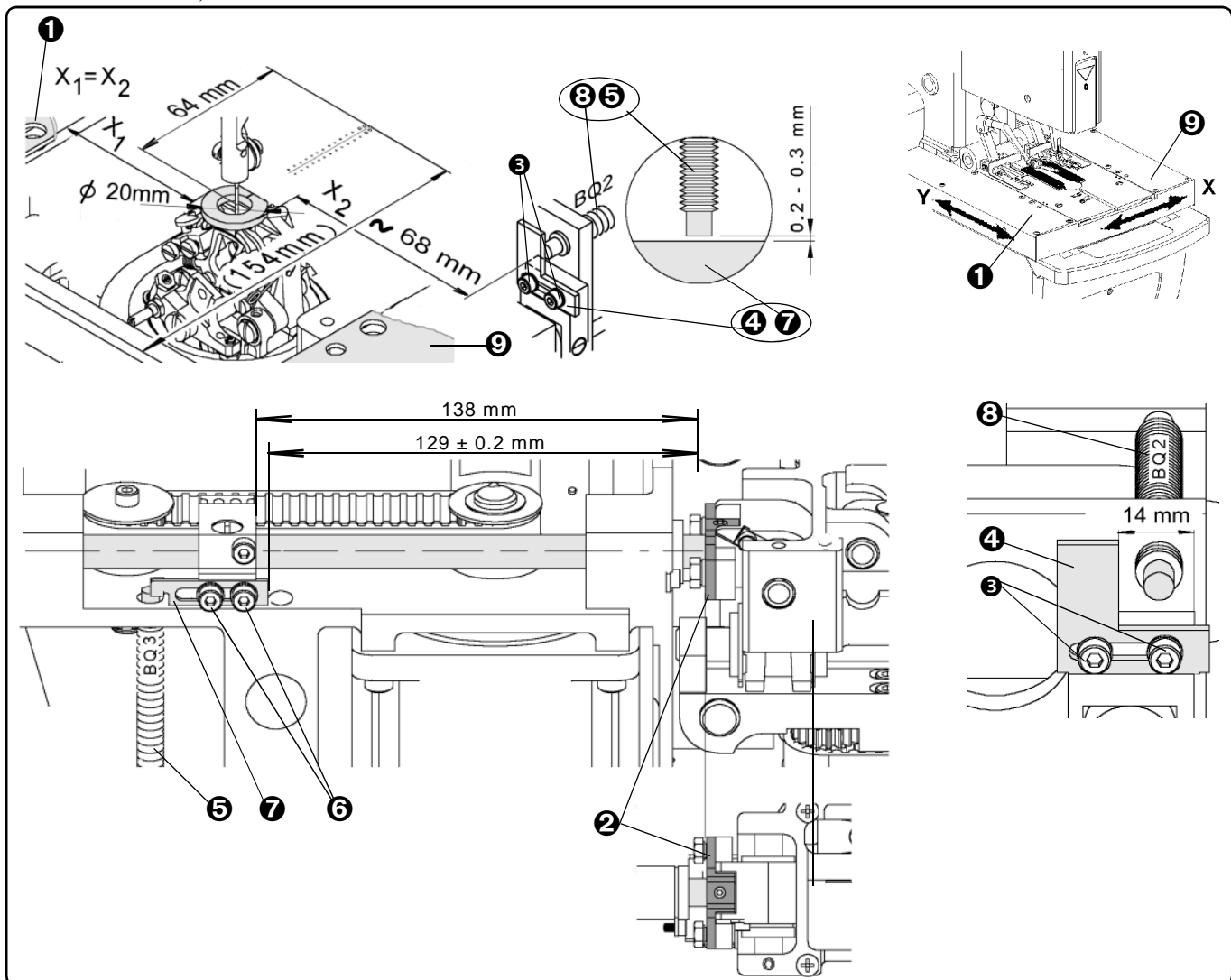



## E - STANDARD MACHINE ADJUSTMENT

### 4. THE RACE MECHANISM ADJUSTMENT

Home position of the working plate is given by position of the plate ⑤ and sensor ⑦ (BQ4). Screw of the sensor plate ⑥ is locked by paint from the manufacturer, that is why only a service technician from AMF REECE can perform this operation during the guarantee period. Make sure there is the buttonhole without eye on the display, stitches inclination  $0^\circ$ , cutting distance 0.0, see section D3, D6.

- 4.1. In the bedplate home position adjust the assembly of the sewing mechanism by the looper beam ① to the operator side.
- 4.2. Adjust the block ② of the needle bar, after loosening the screws ③ of the bevel gear, so that screw ③ in the needle bar is on the left and tighten the screws. When you sew a side stitch, the distance between the needle and the edge of the throat plate ④ must be the same as when sewing a centre stitch.
- 4.3. After loosening the screws ⑥, turn the plate of sensor ⑤ clockwise to the extreme position. The sewing mechanism has to be vertical to the oblong bedplate axis. To check up the adjustment, use the gauge ⑨, according to the bedplate edges ⑩.
- 4.4. When the service mode is activated, punch in the buttonhole shape on the paper. Find if the stitches in the straight part of the buttonhole are vertical to the buttonhole axis and center stitches are turned by  $90^\circ$ . To correct it, rotate the sensor plate ⑤. For better visibility of the centre punctures, adjust the cut distance for large value, for example + 0,5 according to the section D6.

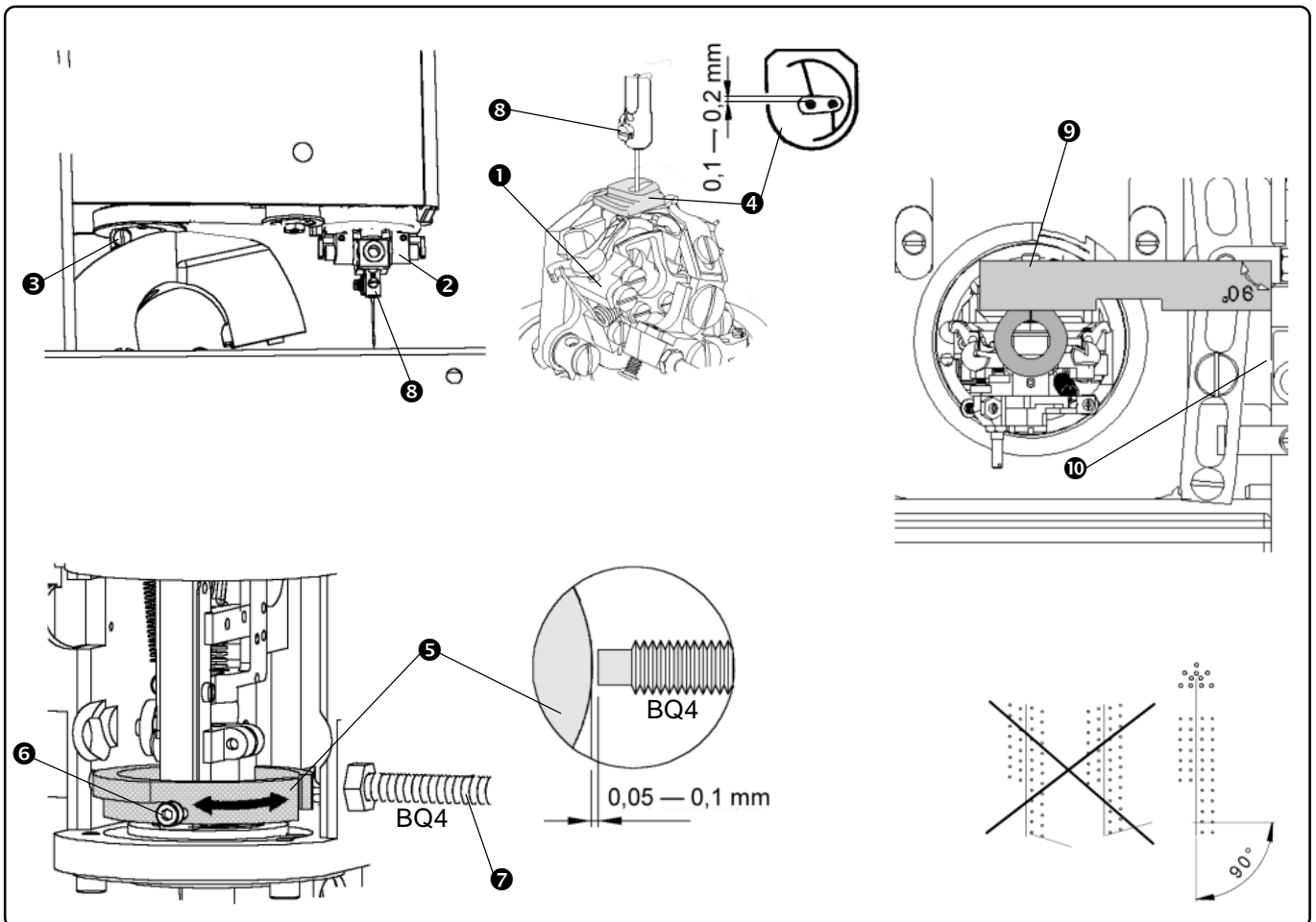

## E - STANDARD MACHINE ADJUSTMENT

### 5. THE SEWING MECHANISM HEIGHT CONTROL

Before any other adjustment, we recommend to check, if the height of the sewing mechanism of the loopers, spreaders and stitching plate is adjusted properly.

- 5.1. The height 6,5 mm of the sewing mechanism support **1**, from the surface for the anvil can be readjusted by inserting or removing the washer **2** under the bearing flange **3**. The support is decreased, if the washer is added - in B direction, if the washer is removed, the support is increased - in A direction. The washers are supplied with the thickness 0,1 (19.0019.6.405) or 0,2 mm (19.0019.6.404). The adjustment can be checked with the sliding gauge - 10 mm from the top edge of anvil base to  $\varnothing$  of the bung **7**.
- 5.2. After inserting the stitching plate, it is necessary to check the distances between the top edges and the top surface of the clamp plates **5**. This distance is adjusted at the factory with the screw **6** under the stitching plate for 0,1 — 0,15 mm. The screws are secured with the LOCTITE 243.
- 5.3. For above mentioned distances, the factory provides the height of the fitting plates surface **9** from the surface to the anvil **10** in range 33,5 -0,2 mm.

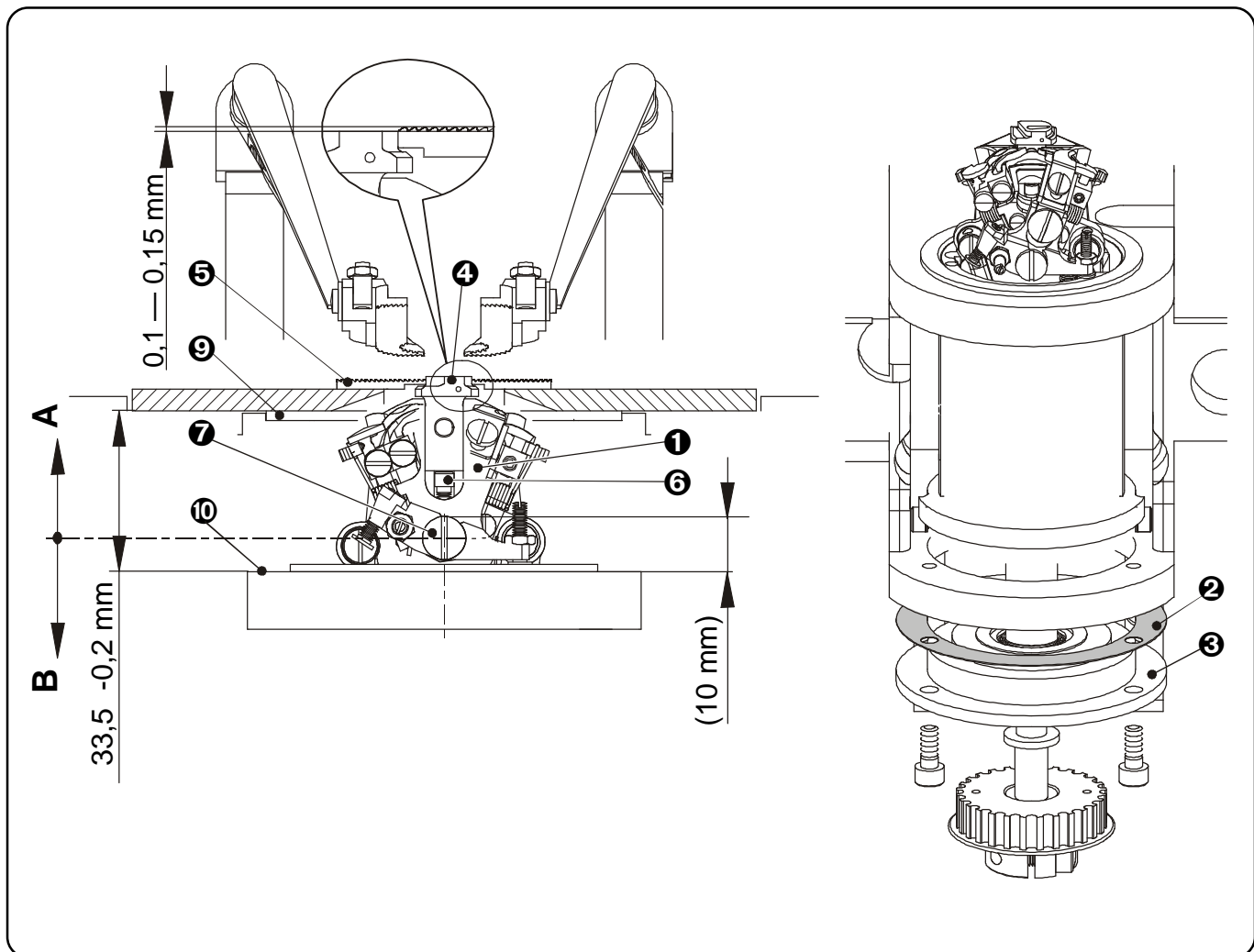

## E - STANDARD MACHINE ADJUSTMENT

### 6. MECHANISM ADJUSTMENT FOR MATERIAL CLAMPING

**WARNING!** Before doing any adjustments, disconnect the air supply and deflate the test of compressed air in the machine.

The basic clamp plates adjustment ❶ with clamp feet ❷ is possible to modify after removing from the machine.

- 6.1. After loosening the screws ❸ adjust the clamp feet ❷ from front to rear (in the Y axis) and after loosening the screws ❹ from left to right (in the X axis)
- 6.2. The adjust feet ❷ clamp against the plates ❸ for 1,2 - 2,0mm overlap.
- 6.3. Remove the side table covers ❺ by removing the screws ❻.
- 6.4. Insert the clamp plates ❶ into the machine.
- 6.5. Adjust the plates lift ❷ for 12mm and after loosening the screws ❸ tighten them again.
- 6.6. Put the side table covers ❺ on and screw them.
- 6.7. Check the proper adjustment when sewing.

Recommended space between the clamp foot and needle during the outer penetration is 1 mm. If the bite size is changed, ensure this space by covering the clamp feet ❷ over clamp plate ❸ - measure A to values. Adjust after loosening the screw ❹ and shifting the clamp plate arm to the correct needed clearance.

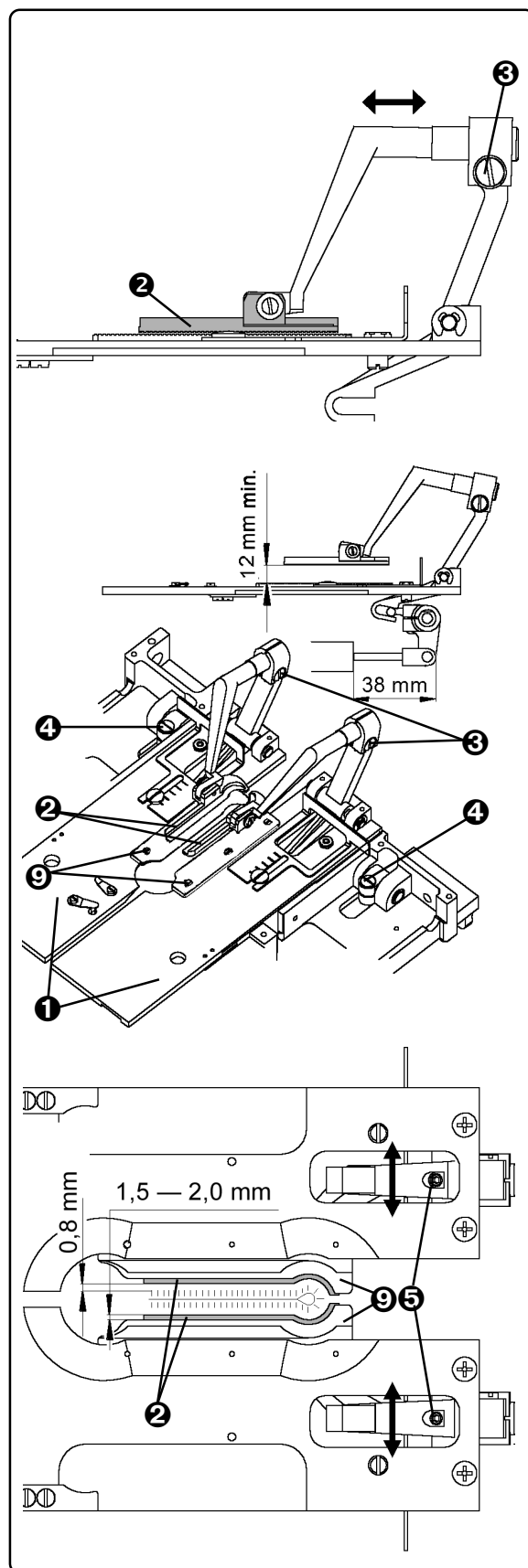
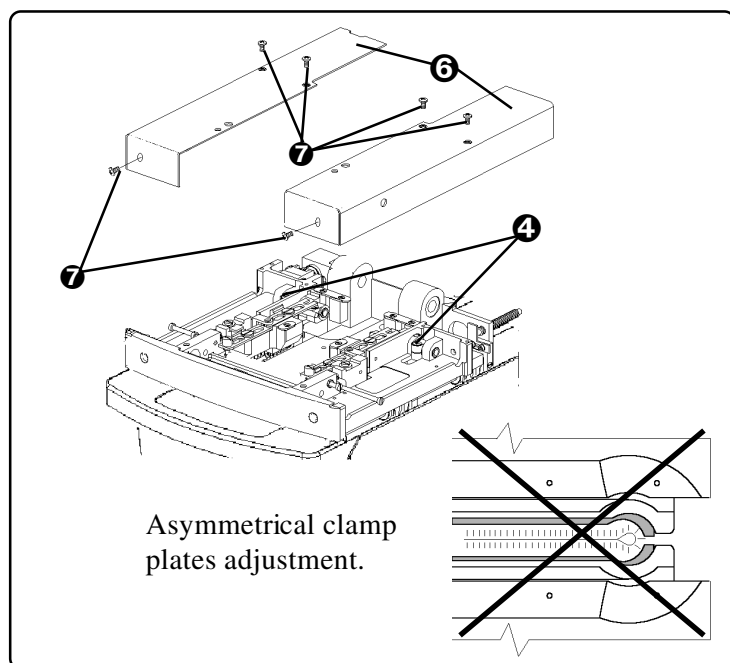

## E - STANDARD MACHINE ADJUSTMENT

### 7. SPREADING OF A MATERIAL

Loose fabric, especially thin, can cause missing stitches unless it is spread. The machine is equipped by a mechanism to control the extent of fabric spreading. It is possible to adjust the mechanism after removing the table covers. Size of the spreading is possible to adjust with covered table.

- 7.1. After loosening the screws ③ is possible to change the spreading size of the every foot clamp separately by the screws ④. By turning the screws ④ clockwise, decreases spreading, counterclockwise increases, maximum is 2,5 mm on one clamp plate. Check it with stepping (section D2) to the place, where is the stitching plate between the clamp plates. The edge of the plats ⑨ has to be 1mm from the stitching plate.
- 7.2. Home position of the levers in spread state is set by the screw ① under the table covers ②. The screw is locked by the yellow colour from the manufacturer, that is why it is not possible to adjust it during the guarantee period. It is adjusted to the measure approximately 9.5 mm (71.5 mm when the plate is inserted and spread).
- 7.3. Basic measure for a control yoke ⑦ adjustment is 27 mm from base for the cylinder holder ⑧ by maximum spreading (loosing the screws ③ ④).
- 7.4. The manufacturer recommends to adjust approximately 0,6 mm. It is difference between the lever stud ⑥ distances before and after spreading.

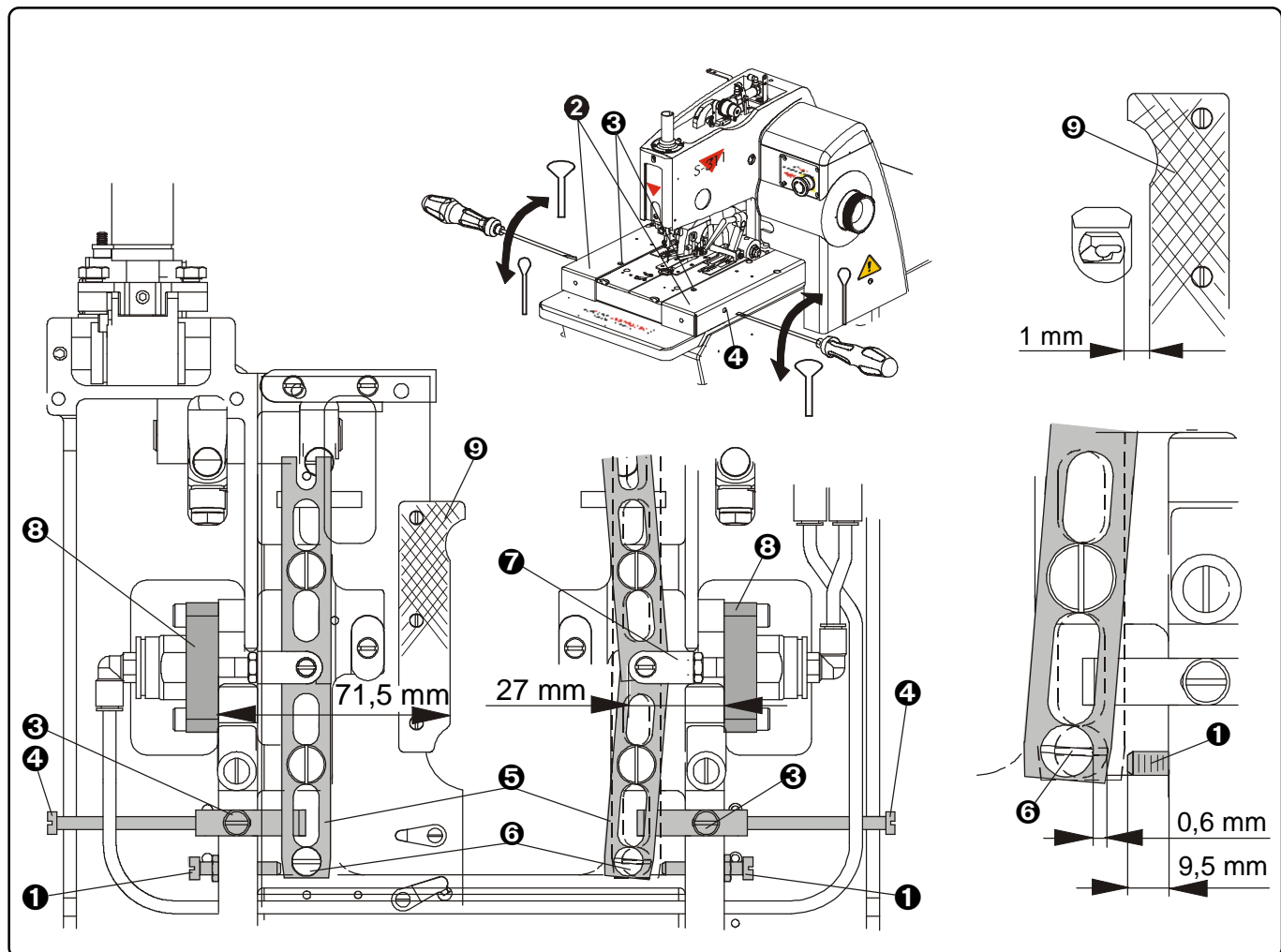

## E - STANDARD MACHINE ADJUSTMENT

### 8. ADJUSTMENT OF THE CUTTING MECHANISM

**Caution :** Before doing the adjustment, it is necessary that the parameters, especially the cutting

space and correction was adjusted on 0 - section D6, buttons

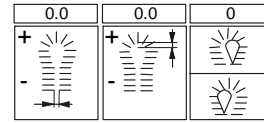

The cut position is given by the point of departure of the stepping motors adjustment. The sensor plates screws are painted against the spontaneous rearrangement. If the cut position needs to be changed, it is possible to adjust the knife position in the program.

Be sure to use the same size of the knife eye. When using the different eye size, the buttonhole will deform, or the eye stitches can be damaged.

The point of departure for the cutting mechanism adjustment is the needle and sewing mechanism. The process is chosen by installing the knife, either to the cutting lever or to the anvil.

- 8.1. **The knife installed into the cutting lever** ③, adjust in the axis X after loosening the nuts ①, tighten the nut ②, on which side the cutting lever should be shifted. Zero position for adjustment is set by the manufacturer. To check the cut use the paper sheet.
- 8.2. **The knife stop adjustment in the axis Y** in the cutting lever, adjust for 68mm after loosening the screws ④. Check by needle puncture on the paper in basic position with the button for cutting. The distance from the eye top to the puncture has to be 64-0,3 mm.

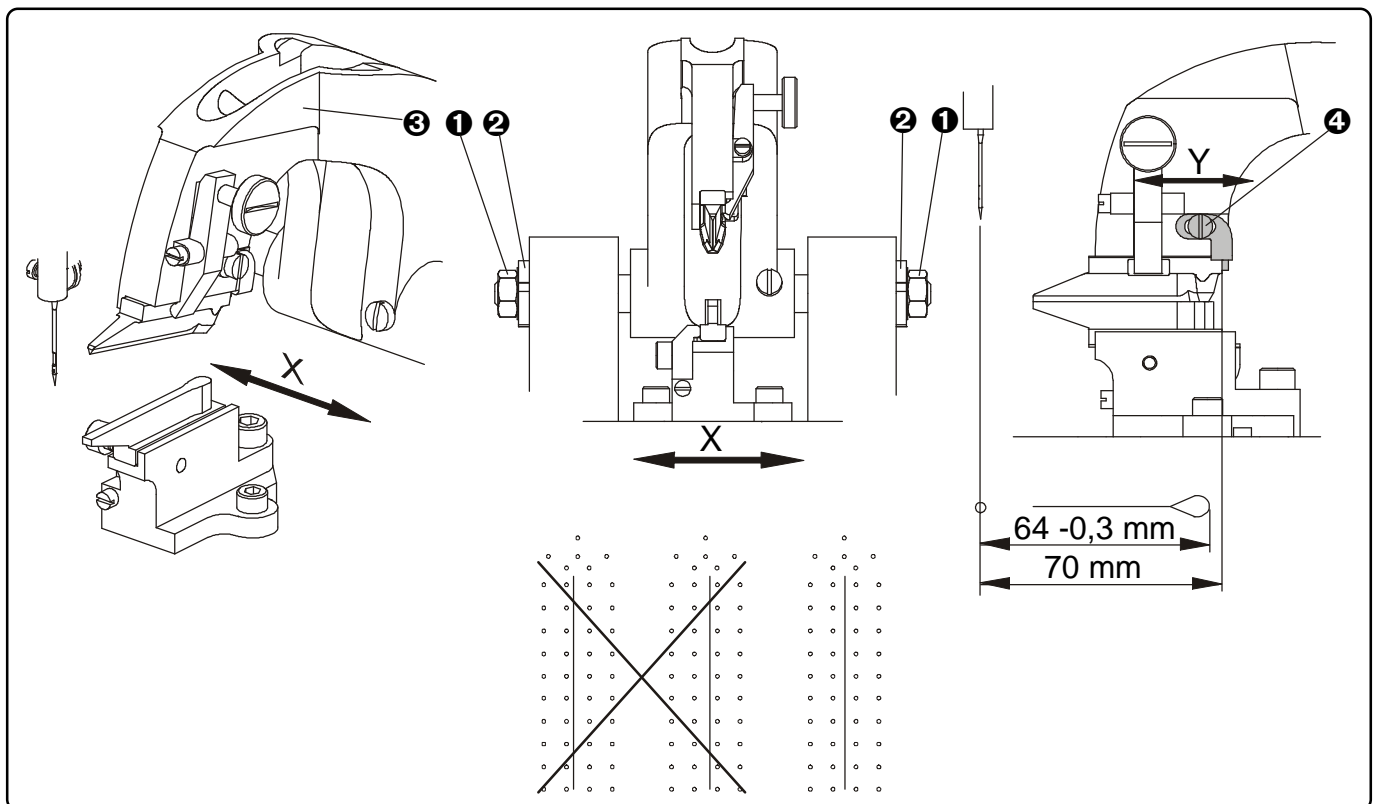

## E - STANDARD MACHINE ADJUSTMENT

8.3. *The knife in the axis X in the anvil* ⑥ loosing the screws ⑤ and change safely the position, to the right or to the left. Tighten the screws.

8.4. *The knife stop in the anvil* ⑥ adjust for 70 mm after loosing the screws ⑦.

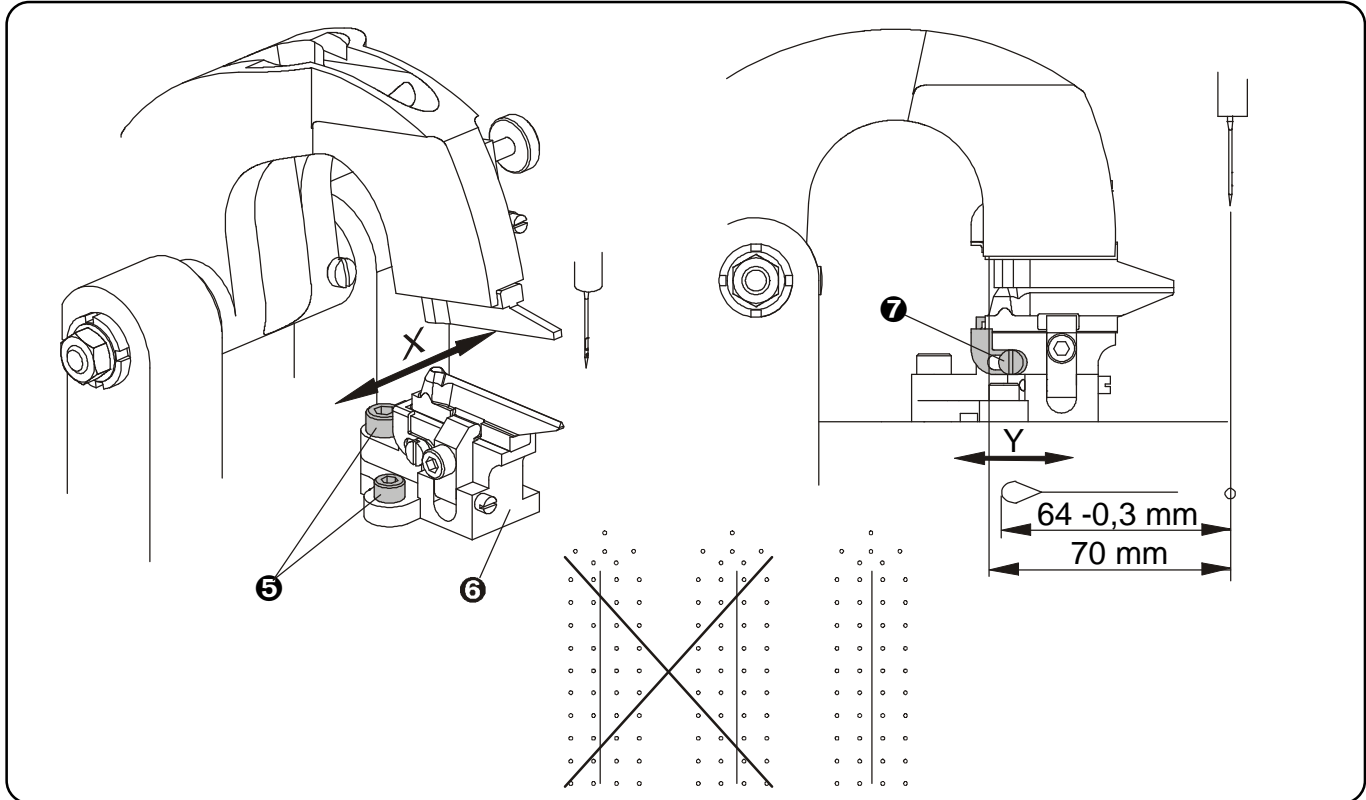

8.5. The pressure of the pneumatic system is adjusted with the regulator ⑧ for 0,6 MPa. This pressure is suitable for all materials for cut lengths to 30mm. For difficult cut, increase the pressure for 1/2 rotation anticlockwise.

8.6. The sensor ⑨ on the cutting cylinder is adjusted approx. for 39 mm.

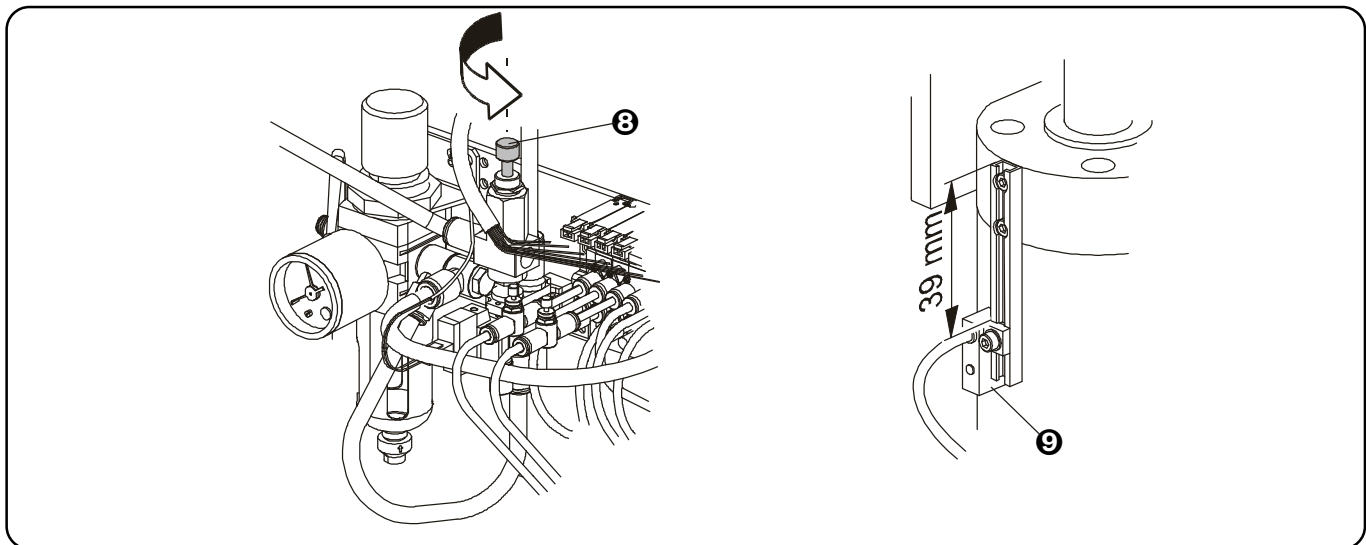

## E - STANDARD MACHINE ADJUSTMENT

### 9. SETTING THE NEEDLE BAR HEIGHT

- 9.1. Remove the machine head front cover.
- 9.2. Turn the handwheel **①** and adjust the needle bar **②** to the lowest position.
- 9.3. Insert the gauge **⑤**, height 9,5 mm, between the needle bar and bedplate.
- 9.4. If incorrect, loosen the screws **③** and move the needle bar up or down to obtain correct distance. Tighten the screws.

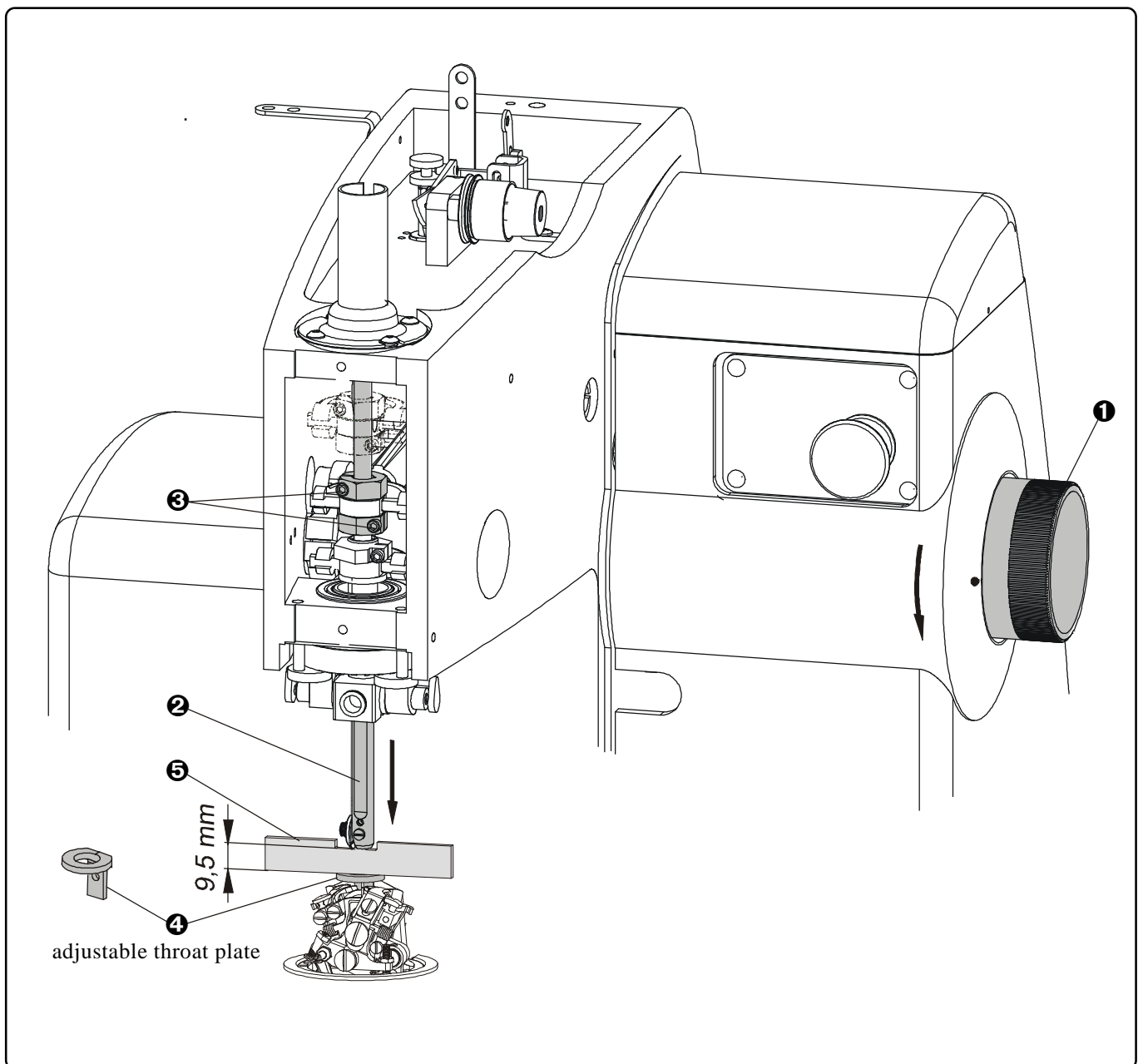



## E - STANDARD MACHINE ADJUSTMENT

### 10. SPREADER AND LOOPER CAM ADJUSTMENT

Locate the cam  $\hat{E}$  on the holder gauge line  $\hat{E}$  when the needle bar is in the lowest position according to the **section E3, point 2**. To turn a cam, loosen the screw  $\hat{I}$ .

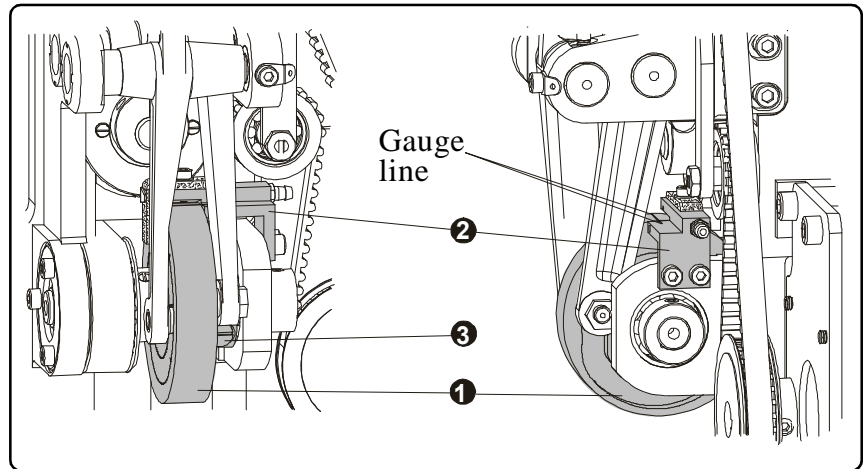

### 11. LOOPERS ADJUSTMENT

11.1. To perform this adjustment, remove the plates and holder  $\hat{19}$  by loosening the screw  $\hat{20}$ .

11.2. After the loosening the bracket screws  $\hat{I}$ , locate left looper  $\hat{J}$  on the axis of the needle  $\hat{D}$ . By turning the handwheel, raise the needle bar from the lowest position, to insert a gauge  $\hat{I}$  by its higher end between gauge support and the needle bar end.

11.3. After loosening the screw  $\hat{N}$  adjust the distance 0.1 - 0.2 mm between the needle and looper tip  $\hat{J}$ . Tighten the screw again.

11.4. Adjust the same space on the right looper  $\hat{O}$  when it passes the needle. To perform it, turn the hand wheel.

11.5. It is important to check the looper distance, according to the point 11.3. Different distance is necessary to adjust by turning the needle bar after loosening the screw  $\hat{22}$  of the wheel  $\hat{23}$ .

11.6. The correct distance between the loopers and needle has to be checked in 4 positions of needle bar plus race. Please see the drawing above.

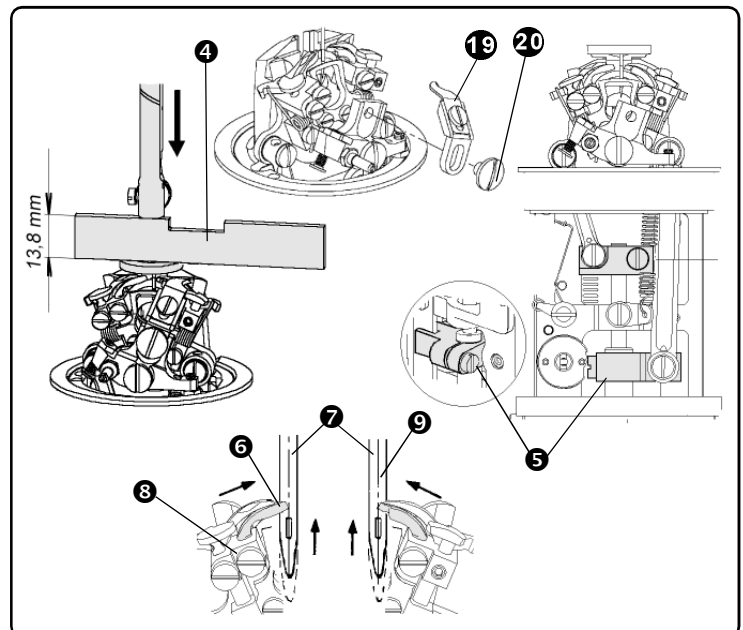
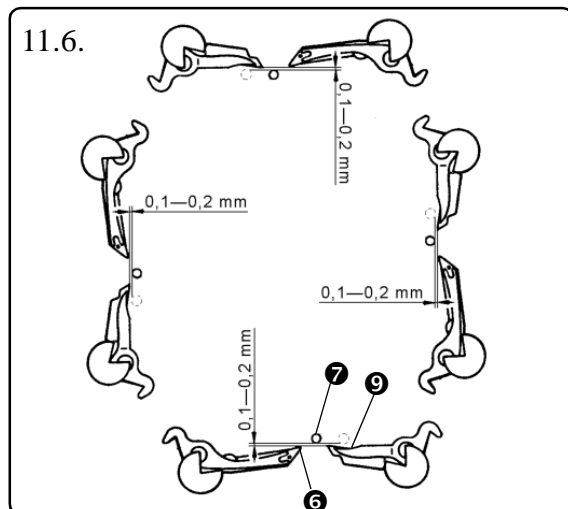
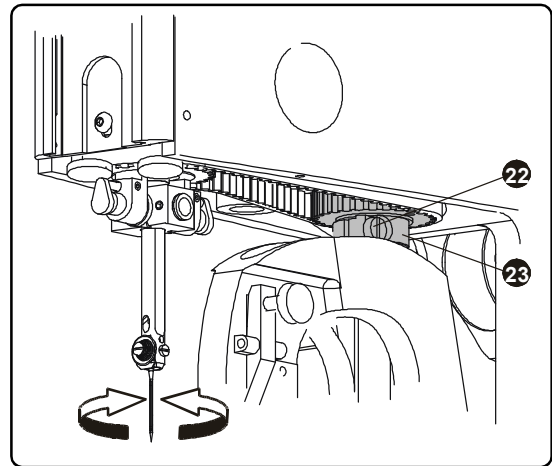



## E - STANDARD MACHINE ADJUSTMENT

### 12. SPREADERS ADJUSTMENT

To reach this, rotate the hand wheel.

- 12.1. Adjust the right spreader  $\acute{O}$  to the right looper edge  $\acute{O}$ , the left spreader  $\textcircled{11}$  with the groove on the hole of the left looper  $\grave{I}$ . To adjust, loosen the screws  $\textcircled{13}$  and adjust the stops  $\textcircled{12}$ . The stops can not slacken.
- 12.2. Check the clearance between the loopers and spreaders (it must be minimal).  
Right - 0,05 mm maximum, so the sewing thread does not go between the right looper and spreader.  
Left - 0,01 mm minimum, so the sewing thread goes between the right looper and spreader.
- 12.3. Check clearance between needle  $\textcircled{D}$  and support  $\textcircled{14}$ . Tilt the support to obtain 0,05 mm, clearance between the needle and looper carrier  $\textcircled{15}$  should be 0,2 mm, for needle Nm 100.
- 12.4. Check the clearance between the needle  $\textcircled{D}$  and the stitching plate  $\textcircled{16}$ .
- 12.5. The position of the left spreader  $\textcircled{12}$  and right spreader  $\acute{O}$ , loosen the screw  $\textcircled{17}$  and carefully place the bracket  $\textcircled{18}$  by turning the spreader rod. The right spreader must be at the home position at the moment when returning to bottom dead position. This adjustment affects stretching out of the left spreader.

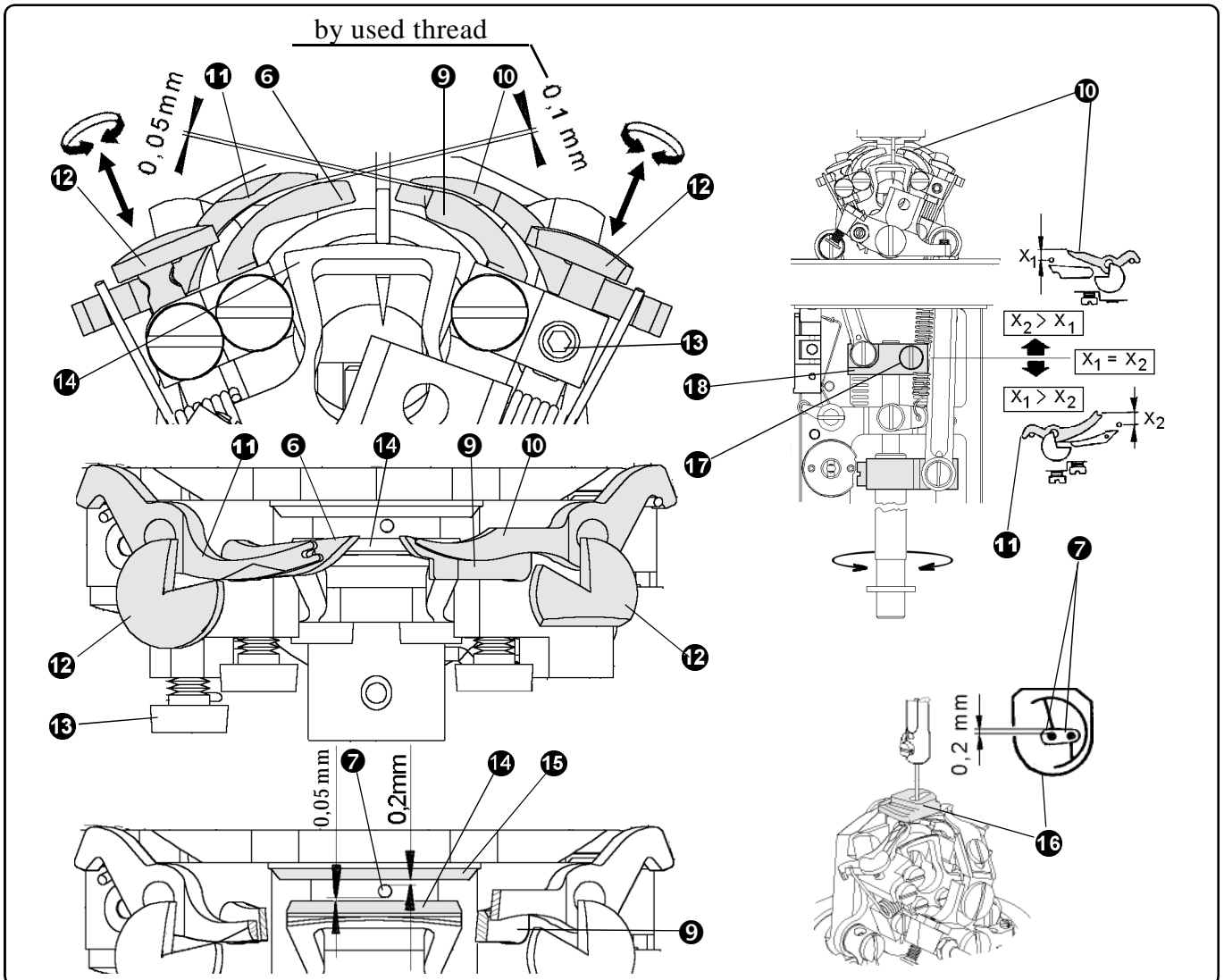

## E - STANDARD MACHINE ADJUSTMENT

### 13. ADJUSTMENT OF THE BITE MECHANISM

S 311 machine is equipped with a mechanism to change electronically the width of buttonhole seaming. The mechanism can be set up for 2 main seaming widths – 2,1mm and 2,7mm. Changing the values electronically on the display, it is possible to modify the main width in the range of  $\pm 0,3$ mm. The mechanism adjustment is such:

13.1. To set the bite to 2,1mm, loose the nut **3** and move the pin **1** to the left all the way to the end stop towards the edge of the stop **2**.

13.2. To set the bite to 2,7mm, loose the nut **3** and move the pin **1** to the right all the way to the end stop towards the edge of the stop **4**.

13.3. In case of 3,4mm bite, remove the right stop **4** and use the stop supplied in the accessory of the machine. It is necessary to pull the stop to the right into the radius gap and guard it with a screw. After this step, exchange the throatplate for this bite and adjust loopers again. If the throatplate is not exchanged, the machine can get damaged!

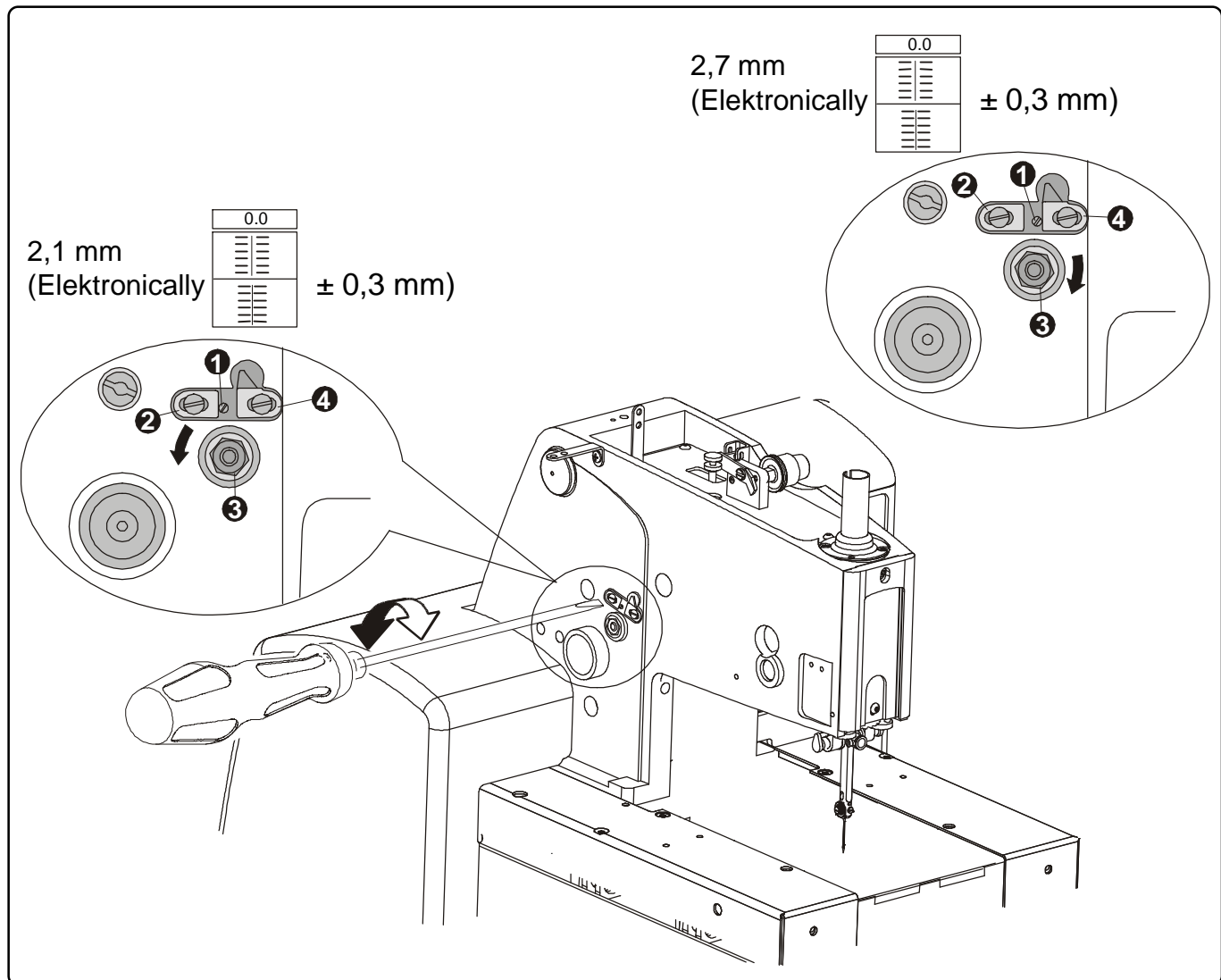

## E - STANDARD MACHINE ADJUSTMENT

### 14. UPPER THREAD TRIMMING MECHANISM - AF/LTT

- 14.1. After installation of the holder with trimming knife **1** adjust the trimming knife after loosening the screw **3** to obtain the clearance 0,1 — 0,15 mm above the right spreader **4**.
- 14.2. Using the screw **2** adjust the trimming knife **1** so that the left side of the knife was covered with the right side of the throat plate.
- 14.3. Position the tip of the trimming knife **1** 0.9 mm in front of the needle **6** by loosening screw **5**. Check the adjustment for keeping the clearance according to the *point 14.2*.
- 14.4. The normal home position of the trimming mechanism **1** is adjusted using screw **7**. Correct adjustment prevents cutting of the looper thread **3** (See diagram).
- 14.5. Adjust the initial position of the control lever **9** to the space 0,05 — 1 mm from stud **10** by the screw **11** after loosening its nut.

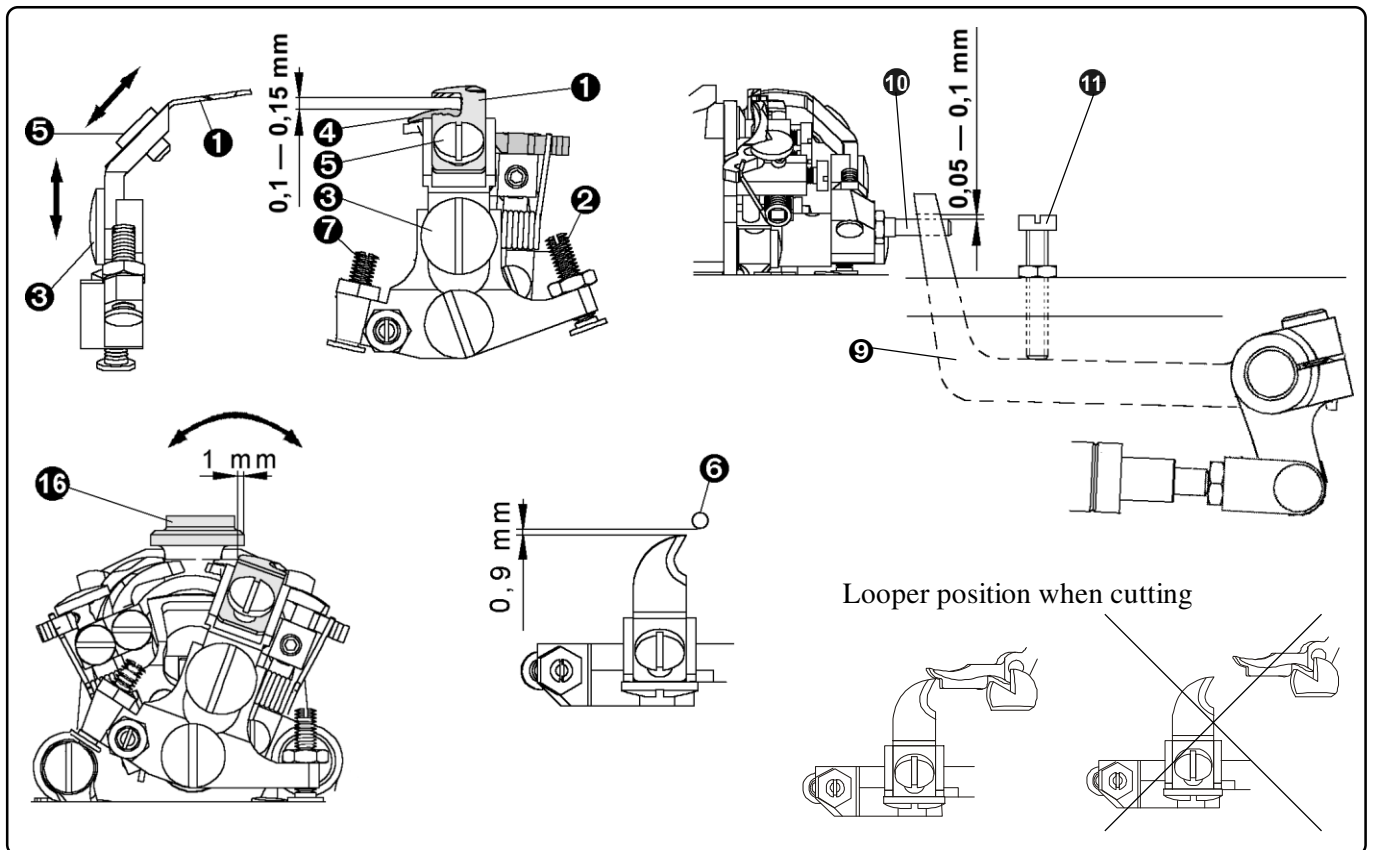

## E - STANDARD MACHINE ADJUSTMENT

### 15. ADJUSTMENT OF THE UPPER THREAD PICK-UP HEIGHT

Is used on the LTT machine as standard. Possible to order for any S-311 machine version.

15.1. The machine needs to be in home position.

15.2 Adjust the clearance 0,5 mm between the nut ❶ and the holder ❷ .

15.3. Loose the screws ❸ to adjust the clearance between of the retainer ❹ and the holder ❺ for the distance 0,5 mm.

15.4 When the clamps of the nipper ❻ ❼ are in the bottom position, adjust them with the nuts ❸ for distance 1 mm from the cover of the clamp plate ❾. (*When sewing the thicker materials, it is possible to increase this distance*)

15.5 Loose the screws ❿ to adjust the clearance between clamps of the nipper ❻ ❼ and the screw ⓫ for the distance 3 mm.

15.6 Adjust the clearance between the clamps of the nipper ❻ ❼ for distance 0,05 mm. Loose the screws ⓬, insert the gauge between the jaws of the nipper. Move the pneumatic cylinder ⓭ so they hold the gauge smoothly and tighten the screws ⓬.

15.7 The machine needs to be in home position. Loose the screws ⓬ and adjust the clamps so the distance 0,05 mm will be in the center of the needle ⓮ or at that position, which would be ideal for sewing the thread from the first part of the buttonhole, so the thread tail is not protruding. After the adjustment tighten screws ⓬.

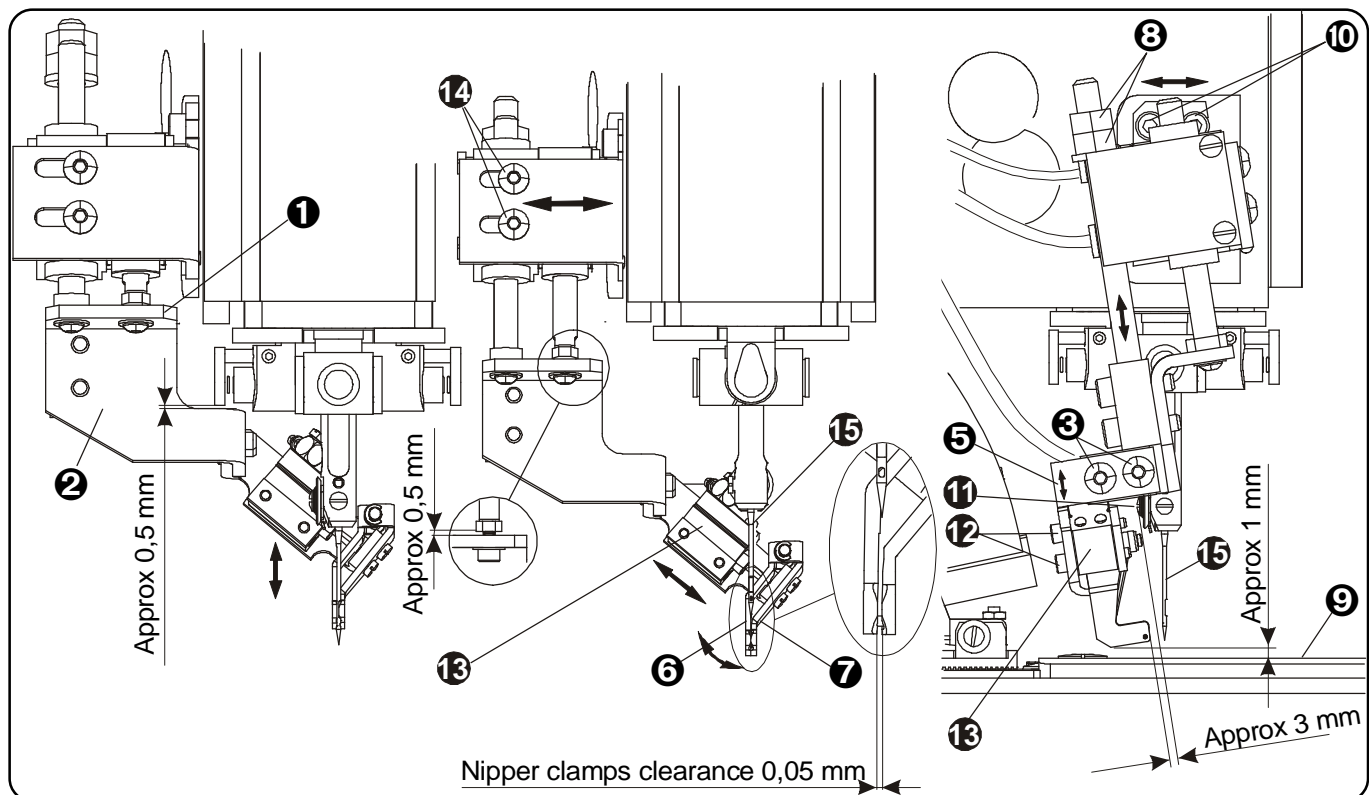

## E - STANDARD MACHINE ADJUSTMENT

### 16. UPPER TRIMMING AND LOWER INTERCEPTION - CT

- 16.1 After installation of the thread retainer **13** with trimming knife **1**, adjust the height of the thread retainer **13** to within 0.2 mm of the top of the throat plate.
- 16.2. Using the screw **2** adjust the trimming knife **1** so that the right edge of the nipper is covered with the stitching plate edge **16** (see picture). The thread holder must lean on the front side of the throat plate to catch and hold the lower thread for next buttonhole sewing. When the trimming knife moves, the thread holder must move over the throat plate without binding. To adjust - loosen the nut of the screw **14** and screw out or in the adjusting screw **15**. Tighten the nut.
- 16.3. Position the tip of the trimming knife **1** 0.9 mm in front of the needle **6** by loosening screw **5**. Check the adjustment for keeping the clearance according to the *point 16.2*.
- 16.4. The normal home position of the trimming mechanism **1** is adjusted using screw **7**. Correct adjustment prevents cutting of the looper thread **3** (See diagram).
- 16.5 Adjust the initial position of the control lever **9** to the space 0,05 — 1 mm from stud **10** by the screw **11** after loosening its nut.

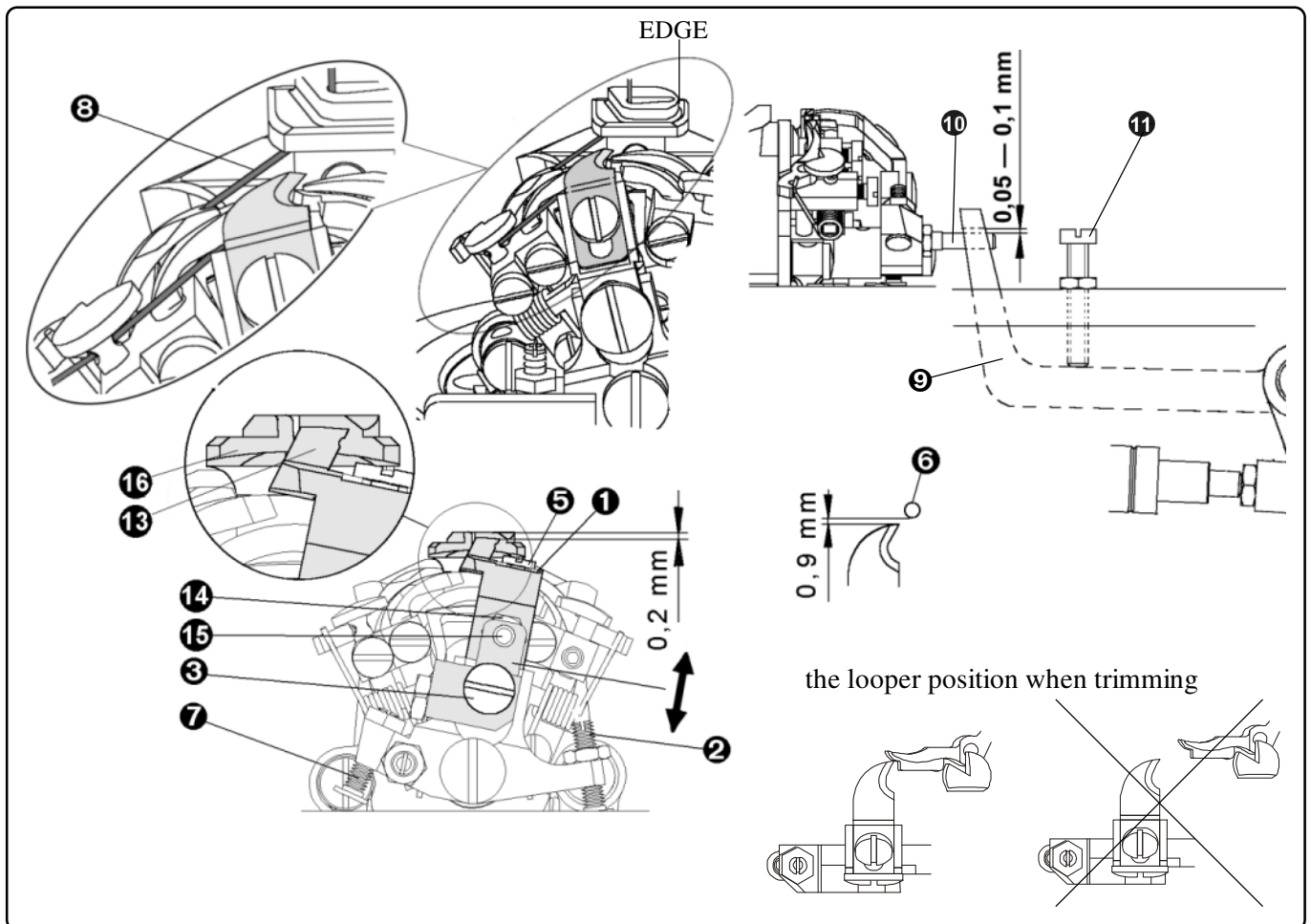

## E - STANDARD MACHINE ADJUSTMENT

### 16.7. *Shears adjustment*

There is a trimming mechanism on the right clamp plate. Loosen the screw ⑨ and adjust the center of the roller ⑧ to 43 mm from the edge of the clamp plate. Tighten the screw ⑨. To adjust the shears, loosen the screws ⑩ and ⑪, and measure 3,8 mm from the top shear to the top of the clamp plate ⑤ by loosening or tightening screw ⑪. Tighten the screw ⑩ and test the cutting of thread. If trimming is not correct, change the dimension to 3.5 mm. Properly adjusted, the shears should show no scratches but trim positively and return to the full open position. If not, check for damage and replace if needed.

### 16.8. *Lower thread and gimp trimming mechanism*

Adjust the distance 33.5 mm between the rod ⑫ and the air cylinder ⑬. Adjust the adjusting screw ⑭ (locked by LOCTITE 243) to the minimal clearance 0.05 mm, to allow the free movement of the rod ⑫.

### 16.9. *Elektronical adjustment of trimmed thread tails*

See section D 7

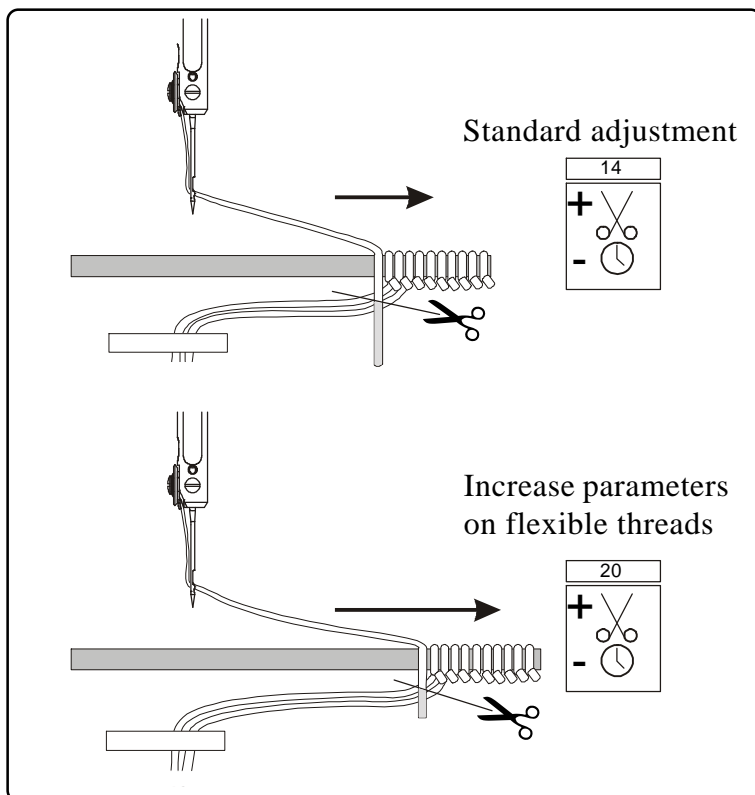
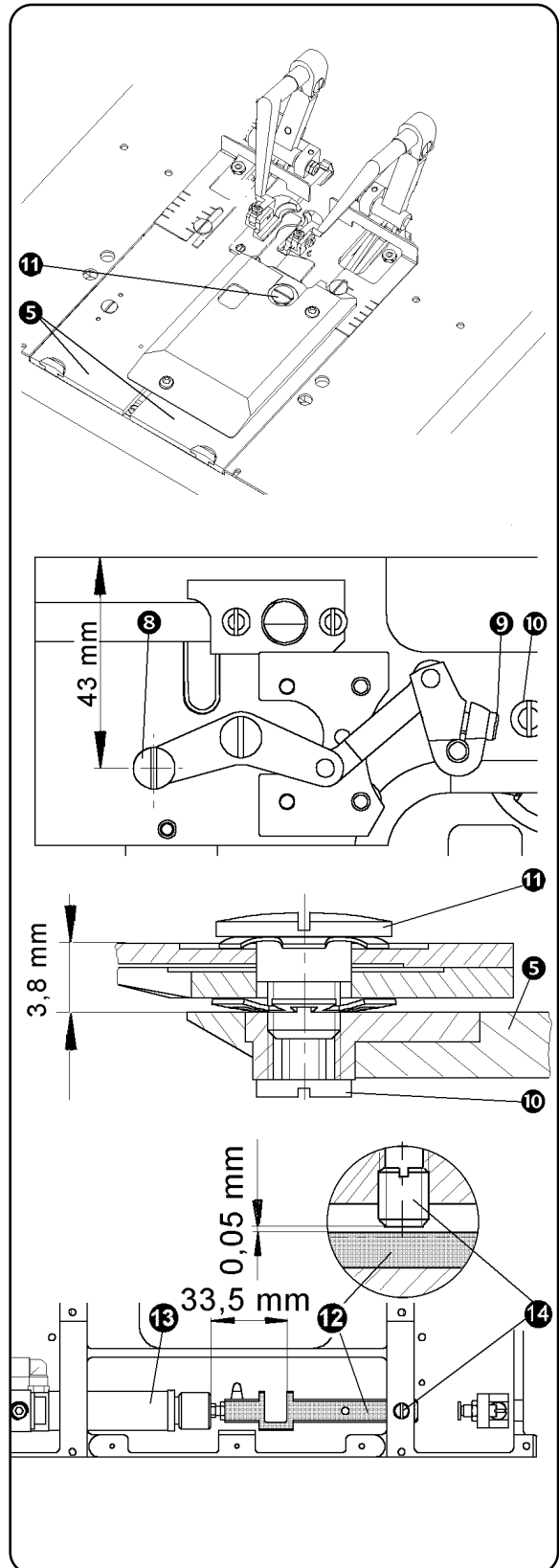

## E - STANDARD MACHINE ADJUSTMENT

### 17. THE GIMP DRAW-OFF ADJUSTMENT - CT

The distance between the stop screw ❶ and the race is 14 mm. The length of the gimp ❷ should be 4 mm after thread is trimmed. To change the length of the starting thread (gimp), loosen the nut ❸ and rotate the screw ❹. If the draw-off is too small, the thread will not be stitched. If the draw-off is too big, there can be dirt in the machine after trimming.

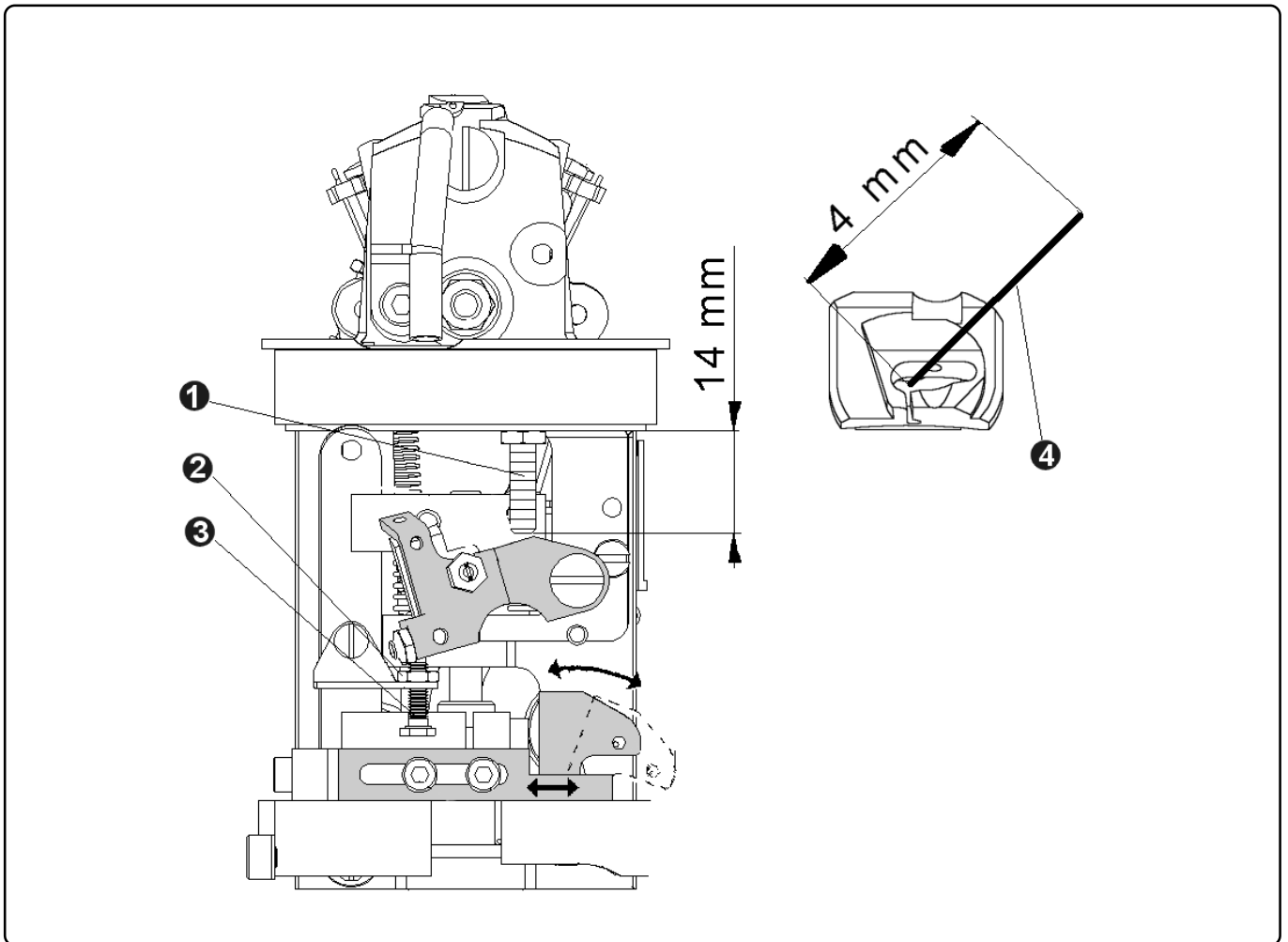



## E - STANDARD MACHINE ADJUSTMENT

### 18. THE TRIMMING MECHANISM ADJUSTMENT - LTT

The lower thread and gimp thread are trimmed before the clamp feet are raised.

1. Adjust so that looper thread and gimp are separated upward and downward by thread catching plate **1**.
2. The clamp fixing plate **2** ensures the correct holding of the upper and gimp thread by lower thread clamp **3** and gimp clamp **4**.
3. Loosen the screw **12** and adjust the distance 55 mm between the clamp plate edge **14** and the bushing axis **13**.  
Tighten the screw **12**.
4. Using the stop screw **10** adjust the maximal position of the cylinder click **9** and the actuating arm **5** so that the fixing knife edge **6** is aligned with mark **8** on the knife **7**.  
Fasten the stop screw by nut **11**.

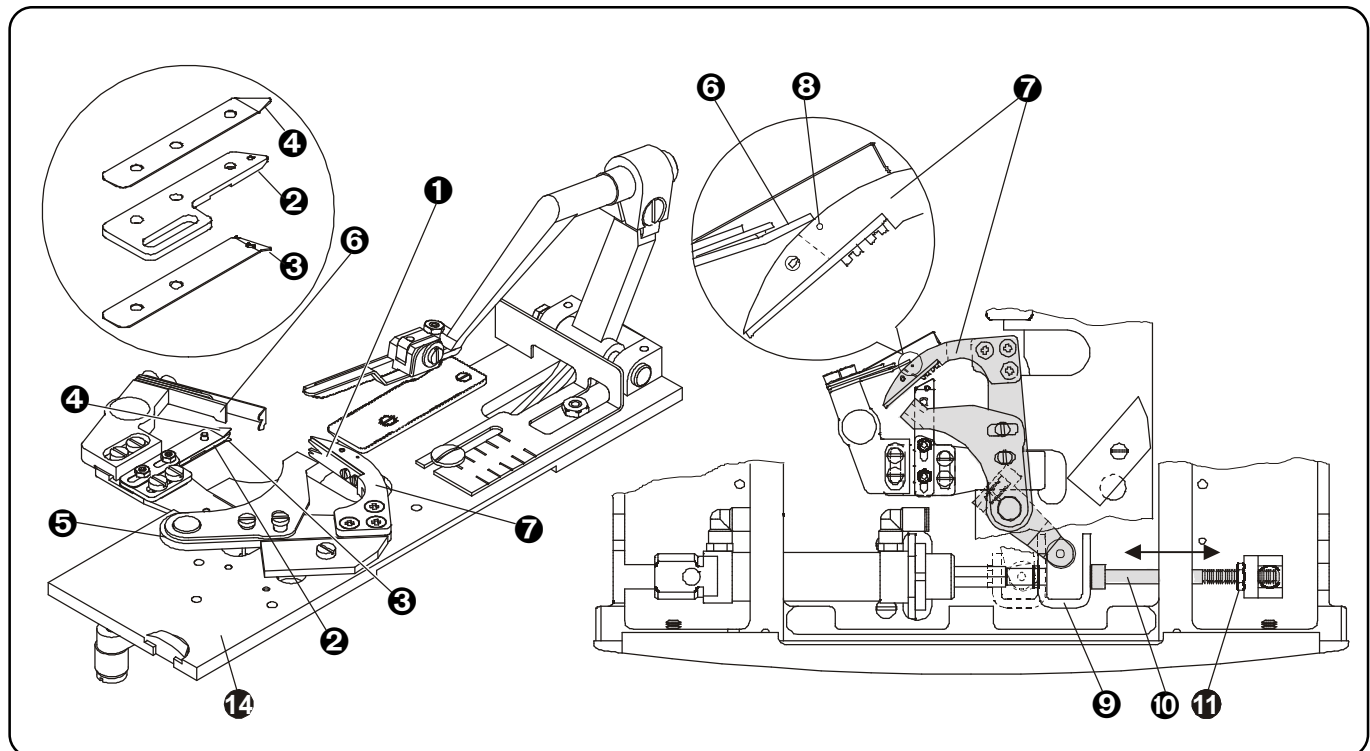
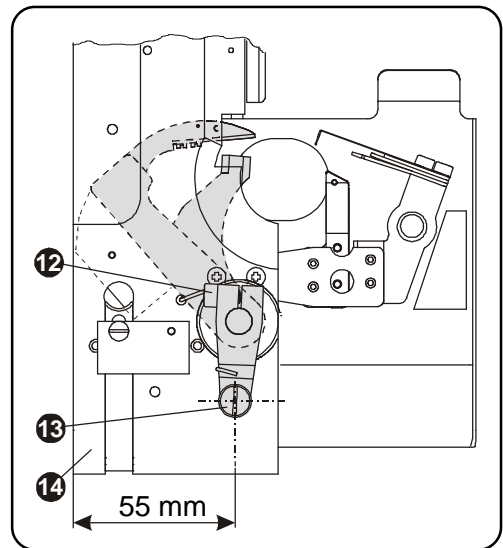



## E - STANDARD MACHINE ADJUSTMENT

### a) knives adjustment - LTT

- a.1. Loosen the screw 18.
- a.2. Turn the knife 7 in direction A and adjust the position of the guide plate 15 so that the lower edge of the guide plate 15 is aligned with knife edge 7.
- a.3. Turn the knife 7 in direction A and adjust the position of the fixing knife 6 to obtain no clearance between them. Adjust the upper edge of the fixing knife 6 to be aligned with knife 7.
- a.4. Align the upper and lower spring 16 17 with fixing knife 6. (Spring boss 16 faces towards the fixing knife 6.)
- a.5. Tighten the screws 18.
- a.6. Adjust the pin 20 to protrude 1.8 — 2 mm on the lower part of the knife 7.
- a.7. Loosen two screws 25.
- a.8. Adjust the knife holder 26 with fixing knife 6 in direction D so that the fixing knife 6 touches the knife 7 in distance 2—3 mm from the blade section (pin 20 is aligned with fixing knife face 6). The larger distance, the bigger pressure on the blade.
- a.9. Tighten the screws 25

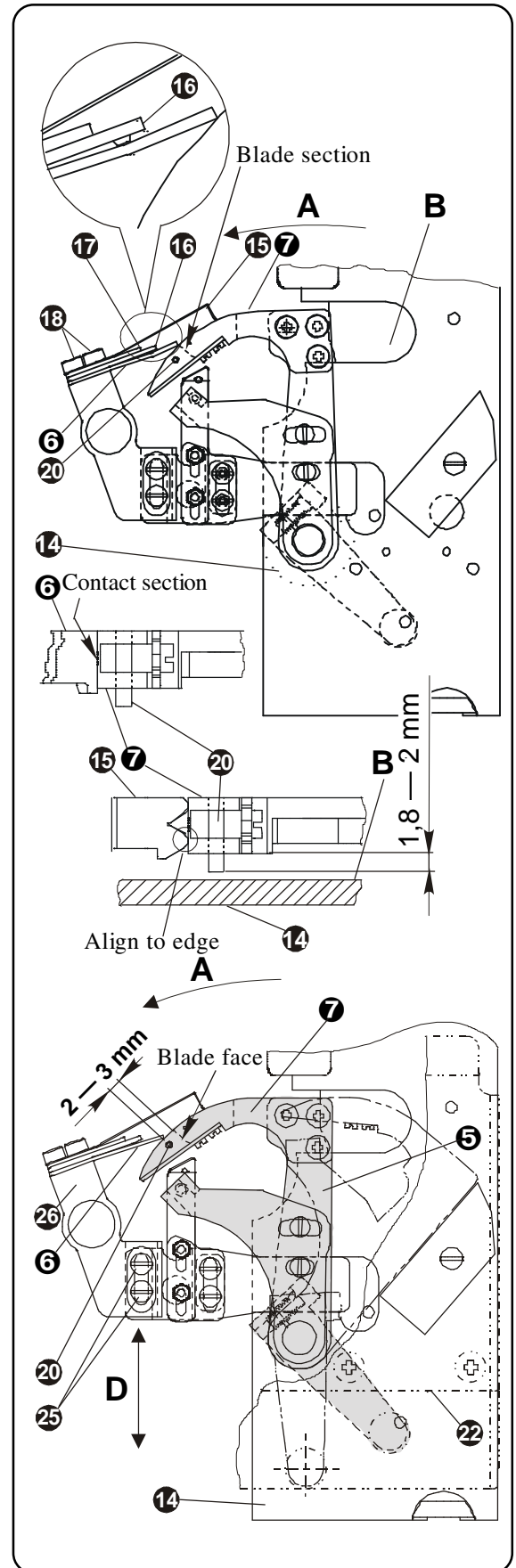

## E - STANDARD MACHINE ADJUSTMENT

### b) lower thread clamp fixing plate adjustment - LTT

- b.1. Loosen two screws 24.
- b.2. Turn the knife 7 in direction A to align the fixing knife face 6 with knife blade section edge 7. Then make as small as possible clearance C (approximately 1mm) between the thread catching plate 1 and clamp fixing plate 2 in direction of arrow B. Check the clearance D between the fixing knife 6 and screw 19, when the fixing knife face 6 is aligned with mark on the knife 7.
- b.3. Tighten the screws 24.

### c) lower thread grasping opener - LTT

Turn the knife 7 in direction A to align the fixing knife face 6 with mark on the knife 7. The lower thread clamp 3 is closed in this position and retains lower thread.

### d) looper thread hauling — LTT

- d.1. Loosen two screws 19.
- d.2. Turn the knife 7 in direction of the arrow A to align the fixing knife face 6 with the edge of the knife blade 7. Align the lower thread fixing plate 2 with thread hauling plate 1 in vertical direction - see picture. Then tighten the screws 19.
- d.3. Sew a sample buttonhole and check if the lower thread is inserted in the lower thread clamp 3 and gimp is inserted in the gimp clamp 4.

### e) lower thread grasping opener - LTT

- e.1. Loosen two screws 23.
- e.2. Turn the knife 7 in direction of arrow A to align the fixing knife face 6 with knife blade section edge 7. Turn the lower thread grasping opener 22 so that the lower side (slant) releases the pin 21 and lower thread clamp 3 returns to the closed position. Then tighten the screws 23.

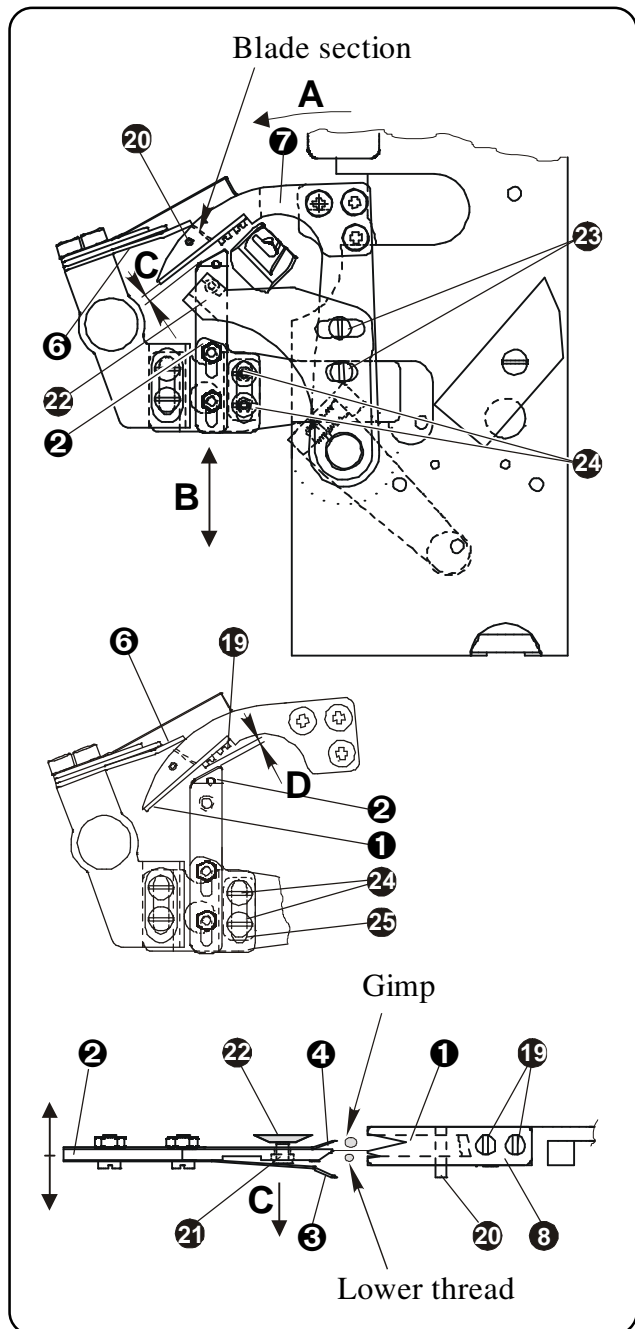

**E - STANDARD MACHINE ADJUSTMENT**

**19. ADJUSTMENT OF THE ADJUSTABLE CUTTING STEEL HOLDER**

To adjust the adjustable cutting steel holder, follow the below mentioned steps:

- 19.1. The distance between the sensor plate and the rear edge of the adjustable cutting steel holder is 14 mm.
- 19.2. The distance between the sensor plate and the sensor must be 0.3 mm.
- 19.3. Adjust the clearance 3.5 mm between the adjustable cutting steel holder and the timing belt pulley.
- 19.4. Adjust the distance 68 mm between the stop of the cutting lever and the point of the needle.
- 19.5. Loose the clamp screw ❶ to adjust the correct cutting length by moving the cutting steel.

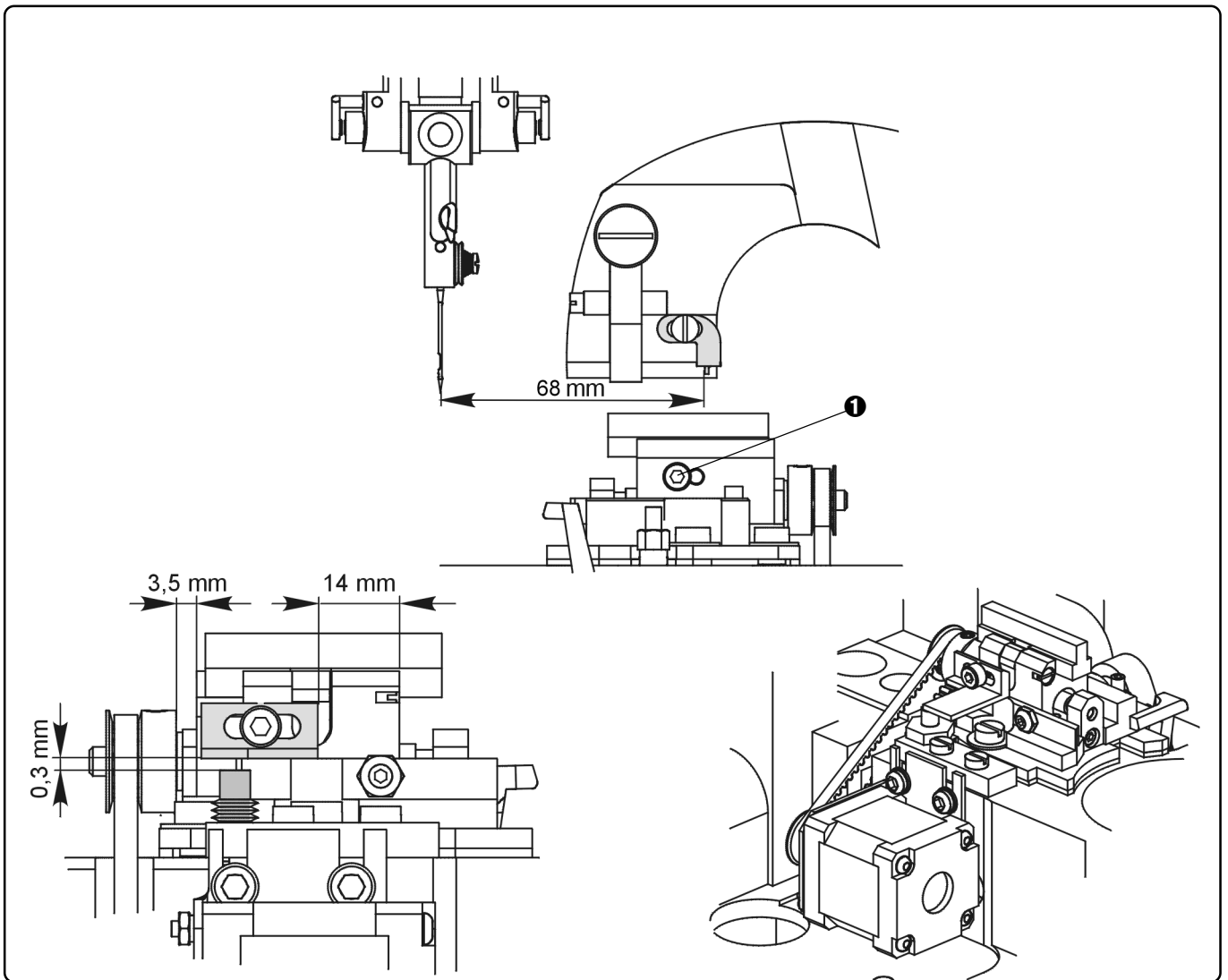

## E - STANDARD MACHINE ADJUSTMENT

### 20. SETTING THE THREAD TENSION AND THREAD DRAW OFF

A thread tension change may be needed if the thread and fabric change. The thread tension influences the appearance of the buttonhole. It is necessary to use quality threads with little elasticity. Check to be certain all parts that the thread passes through are smooth and polished with no burrs or sharp edges.

<i>Recommended thread tension:</i>	upper thread	0,8 N cotton	1,0 N PES
	lower thread	0,5 N cotton	0,8 N PES
	thread draw off spring	0,3 N cotton	0,5 N PES

When using lower quality thread it is necessary to exchange the spring with the spare one, which is in the drawer of the machine.

- 20.1. By turning the tension knob **1** clockwise, *the top thread tension* increases, anti-clockwise decreases.
- 20.2. By turning the tension knob **2** clockwise, *the bottom thread tension* increases, anti-clockwise decreases. After loosening the screw **6**, it is possible to adjust the preloading of the take-up spring **3** by turning the lever **7**.
- 20.3. Increase the stud pressure **4** by loosening the screw **5** and moving the bracket **5**. The ends of the threads will be extended during the trimming.
- 20.4. Thread tension size is possible to adjust after loosing the screw **8** moving thread guide **7** up (*increasing*) or down (*reducing*).

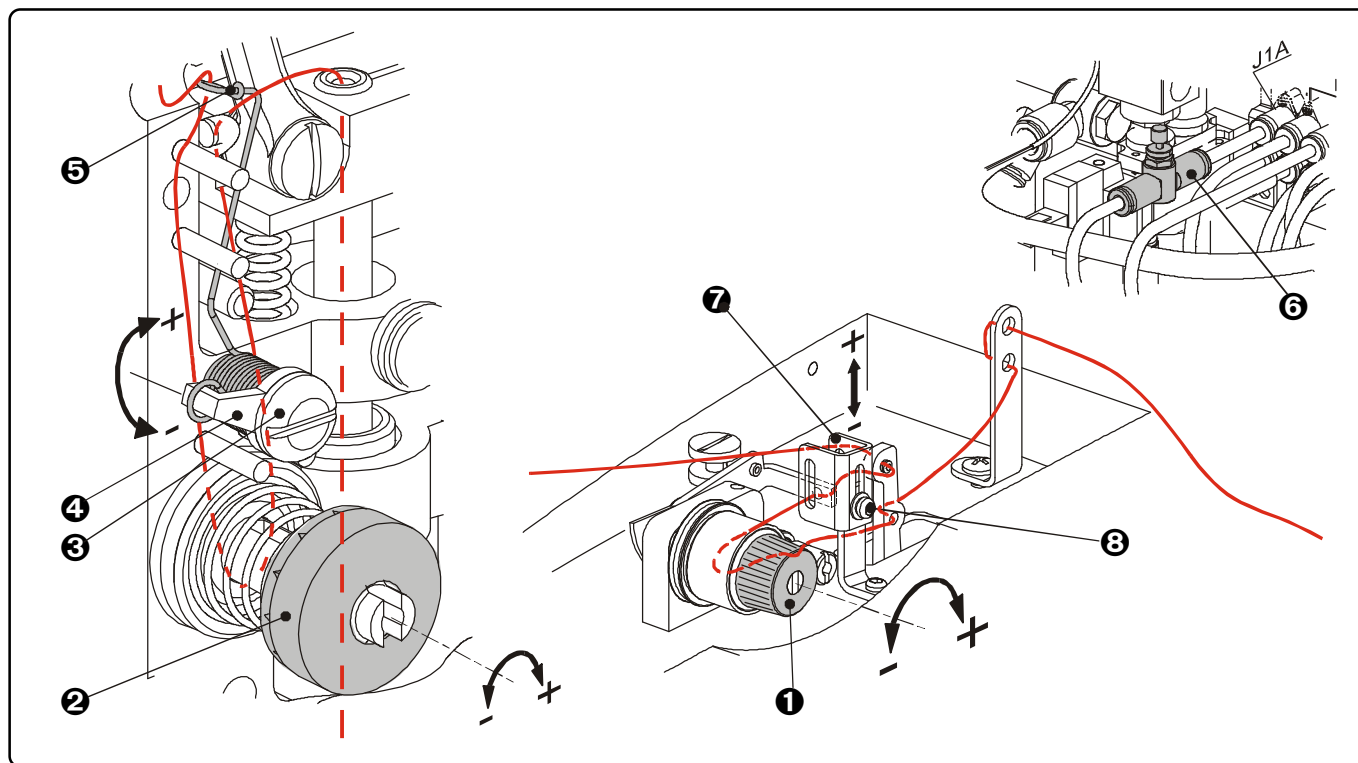

## F - MACHINE MAINTENANCE

- Warning:**
- Check electrical cables for damage.
  - Check if the safety covers are in a good condition. Order or replace damaged covers.
  - Keep your hands out from the needle space and cutting mechanism.
  - Do not modify the machine in any way, which can eliminate its safety parts.

- Caution:**
- Do not neglect periodic maintenance.
  - If you have fault in electrical power supply, switch off the operating switch (circuit breaker).
  - Do not damage, correct and remove safety labels.
  - Do not work with the machine when you are under the influence of drugs or alcohol.
  - User has to ensure the lighting of the working area minimal 750 Luxes.

### 1. CLEANING AND MAINTENANCE OF THE MACHINE

- 1.1. Switch the power off and disconnect the air supply.
- 1.2. For cleaning and maintenance, remove the clamp feet by removing the protecting latches **1**. Lift the clamp feet and pull it to the operator. Remove the locking screw **3** and fold the rear cover **4**.
- 1.3. Clean the thread lints and fabric from the sewing area - guides and thread tension. To move the sewing mechanism, turn the hand wheel **6**. It is also possible to turn the race by hand. The machine head can be raised to the position where it is locked by a strut which is controlled by a button **5**. By pressing the button **5**, the machine can be lowered to the working position.  
**WARNING!** Possible serious injury when lowering the machine head.
- 1.4. Lubricate the machine according to the section **F4**.
- 1.5. Check if the oil reservoir **7**, under the machine, is full. It is necessary to liquidate used oil according to the environment regulation.

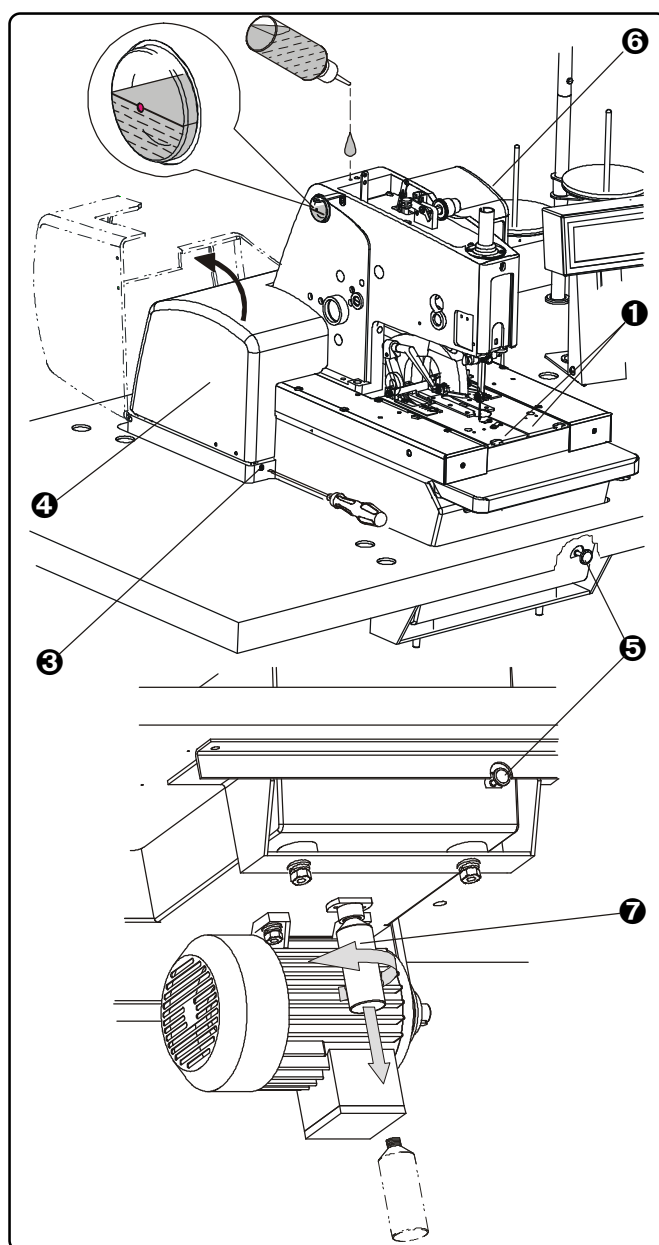

## F - MACHINE MAINTENANCE

- 1.6. Using a screwdriver, loosen the locks **18** on the control box door. Using a wrench, loosen 4 screws **19** on the fan rack **13**.

**CAUTION!** When loosening the last screw, hold the fan **14** by hand inside the control box to prevent it from dropping into the control box. Insert the screwdriver into the rack **13** and by pushing the screwdriver through the cleaning pad **15** remove the plastic cover **16**. Remove the cleaning pad. Remove the dust from the cleaning pad or in case of considerable dirt, wash it using a mild detergent. Perform the same cleaning on the rear fan **17**.

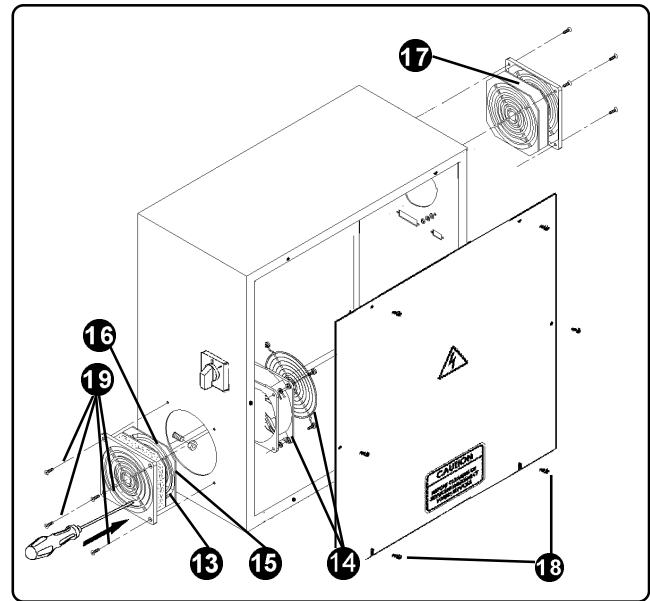

- 1.7. Maintenance of air regulator contains **check of the condensate** and possible replacement of the filter element **9**. The level of condensate must be 10 mm below the filter inside of the desliming receptacle **10**. Lower ring of the nut **12** signals this height.

Open the bleeder screw **11** by turning it counter clockwise. The condensate can then flow out. Tighten the screw again.

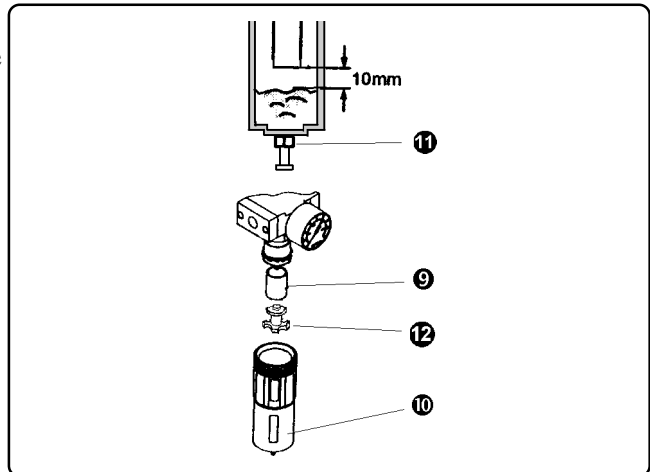

**With worse flow despite same pressure setting** replace the filter element **9** after stopping the air supply. Unscrew desliming receptacle **10** anticlockwise and ventilate. By unscrewing the nut **12**, loosen the filter element **9**, place the new one and assemble the device in reverse order.

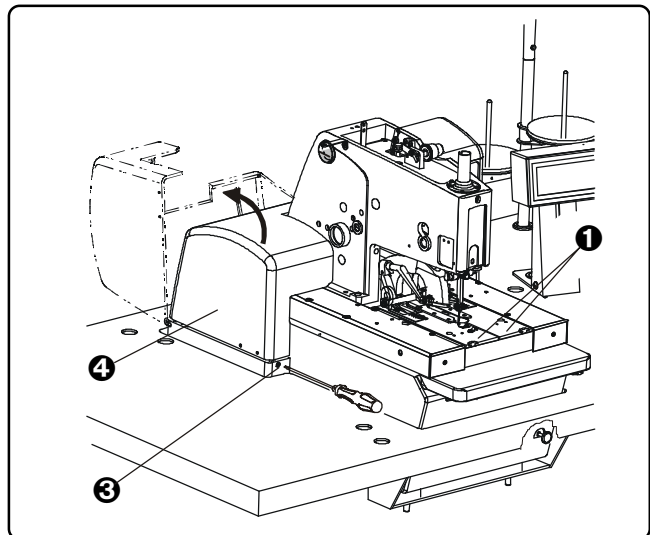

- 1.8. Perform visual check of mechanism especially in area of sewing mechanism. Make sure that in this area are not any scraps of threads and fabric.
- 1.9. When the maintenance and checking is finished, close covers **4**, folding cover lock by the locking screw **3**, put back the clamp plates and lock them by clamp support plates **1**, then continue with work.



## F - MACHINE MAINTENANCE

### 2. PERIODIC MAINTENANCE

- once a day* (8 hours of operation) - cleaning of the sewing mechanism area and inner frame of the machine
- once a week* (40 hours of operation) - visual check - external and internal mechanism  
 - lubrication of needle bar and sewing mechanism  
 - fill oil into reservoir with oil level indicator
- once a month* (300 hours of operation) - check the clearance in sewing mechanism drive  
 - check the screw connections tightening (obtain values below)  
 - check the condensate in regulator  
 - check the waste oil reservoir

Recommended values for screws tightening (Nm)			
M3	 0,5	 0,6	 0,8
M4	1,2	1,5	2,0
M5	2,5	3,0	4,0
M6	4,0	5,0	7,0
M8		8,0	16,0
M10		10,0	30,0



## F - MACHINE MAINTENANCE

### 3. SCHEME OF THE LUBRICATION DISTRIBUTION

The machine is equipped with needle and ball bearings, which in combination with two lubrication circuits significantly decrease required maintenance.

**Circuit I** for lubrication of the arm has oil in reservoir of the barrel. The lubrication of lower unit is made by oil in frame recess - **circuit II**. In case of replacement of any branch of distribution it is possible to order the tube sets and wicks. Replace according to the illustration below:

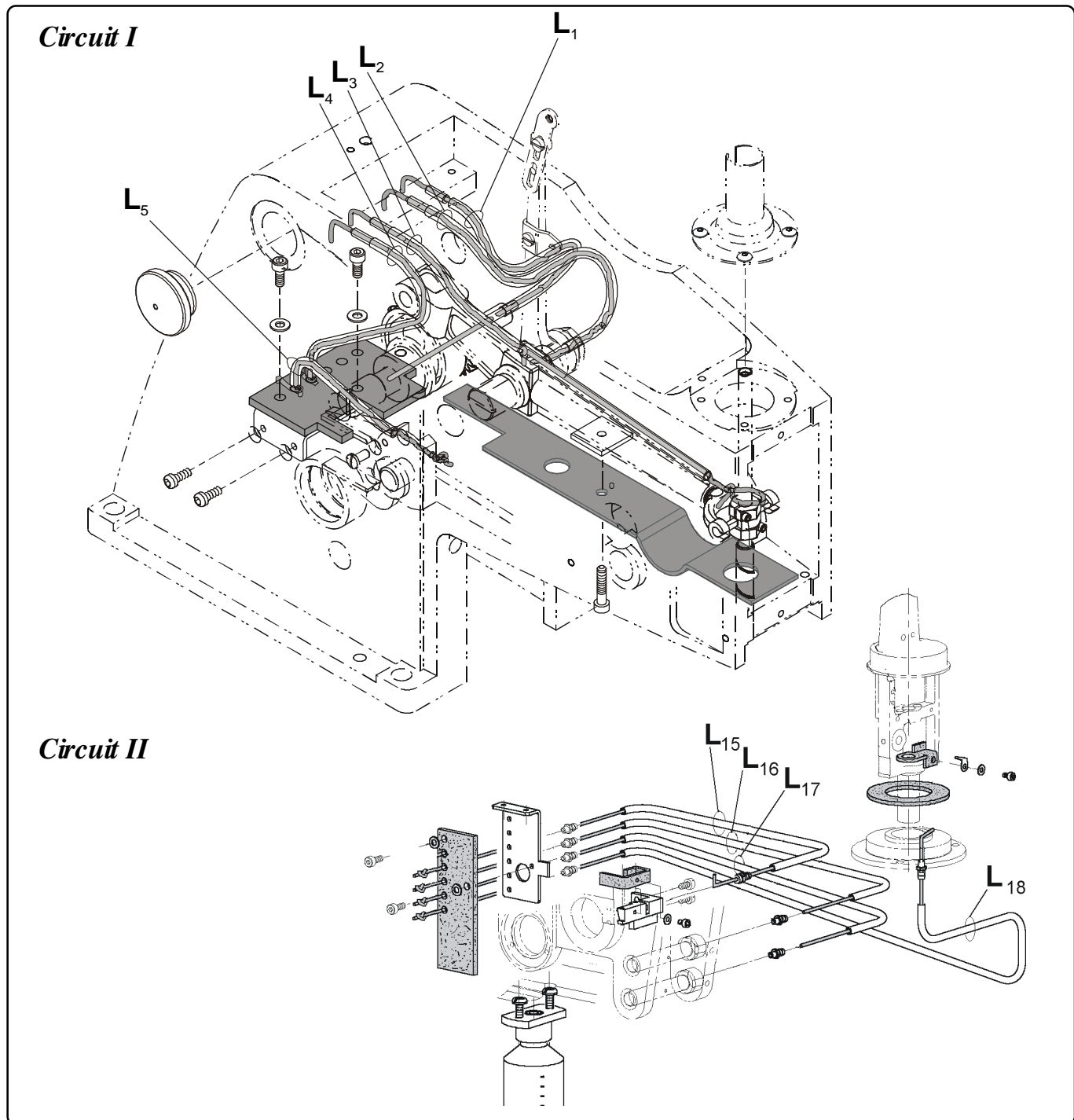



## F - MACHINE MAINTENANCE

### 4. MACHINE LUBRICATION

- 4.1. It is necessary to remove preserve oils and lubricate the places shown below before the machine is switched on for the first time or after a long idle period. Use ESSO TERESSO 32 or similar quality.
- 4.2. The amount of oil in the reservoir **15** is indicated by the red mark. Too much oil may cause its overflowing from the base area.
- 4.3. The reservoir is filled by approximately 10 cm<sup>3</sup> of oil through filling opening **1**.
- 4.4. The lubrication of the needle bar is performed after unscrewing the screw **3** and removing the cover **2**. Few drops of oil drop on needle bar above the bearing **4**, on the centre of the needle bar **5** to the area where the spiral lubricating groove is and to the space between the washers **6** and surface. Install the cover **2**.

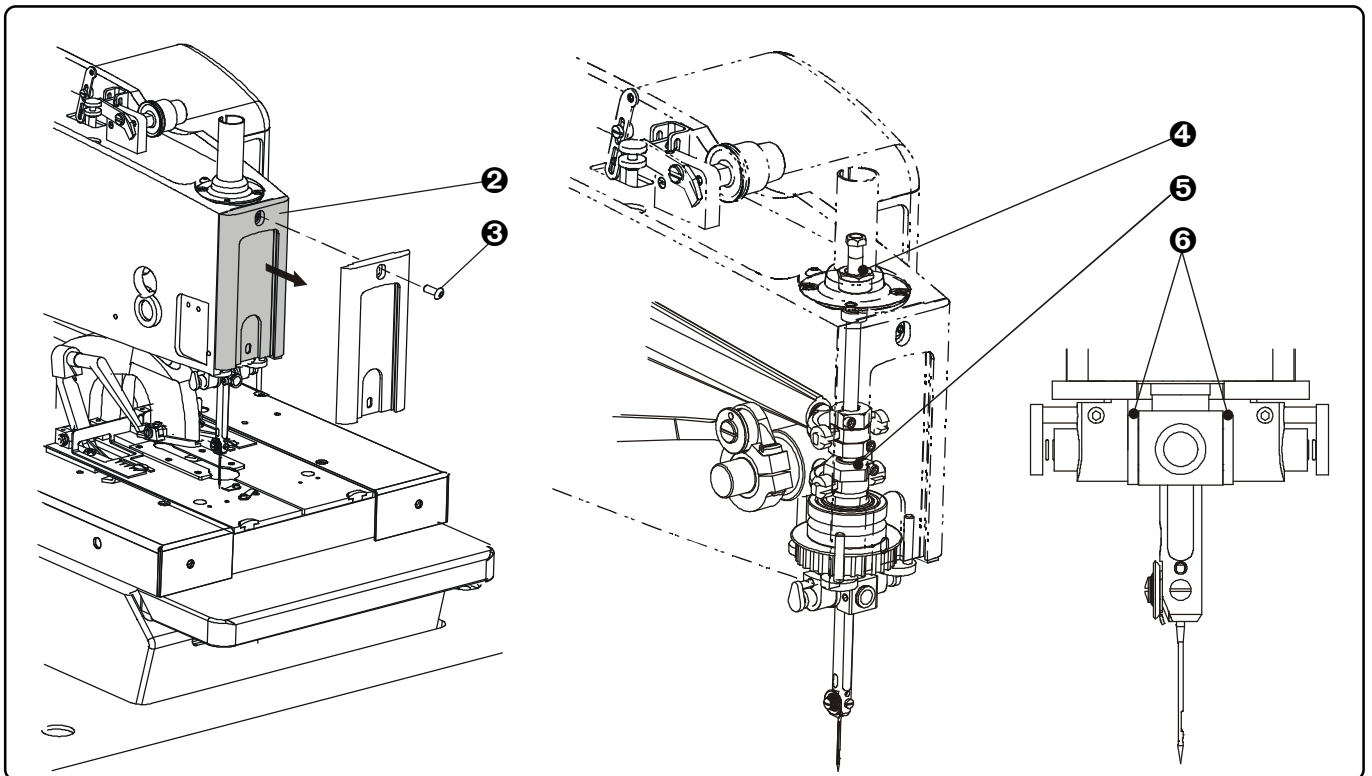
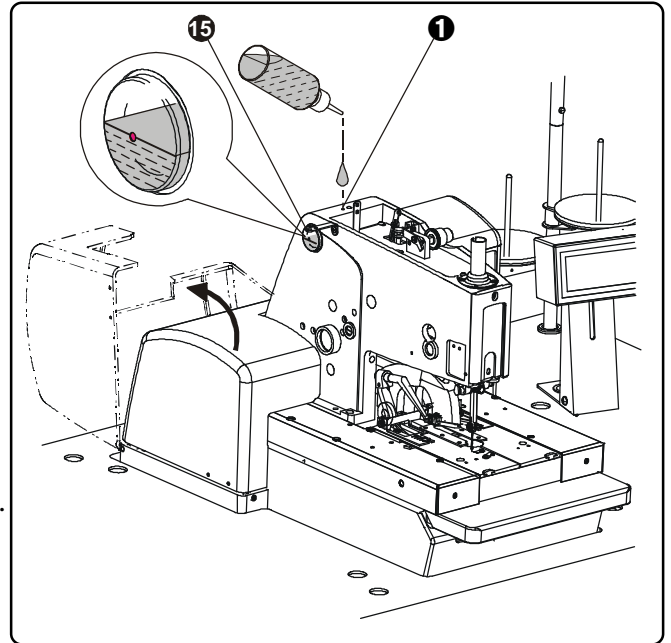

## F - MACHINE MAINTENANCE

- 4.5. Remove the feet plate according to the part **E2, point 2** and oil the bushing **7** and **8**, rod of the spreader **9** and **10**, stud **11** and shafts **12**, **13** by one or two drops of oil to the marked places on the drawing shown and on the machine are those places marked by red dots. To access to the shafts, tilt the machine head after opening the rear cover and after turning the race by hand according to the section **E2 point 2,3**.

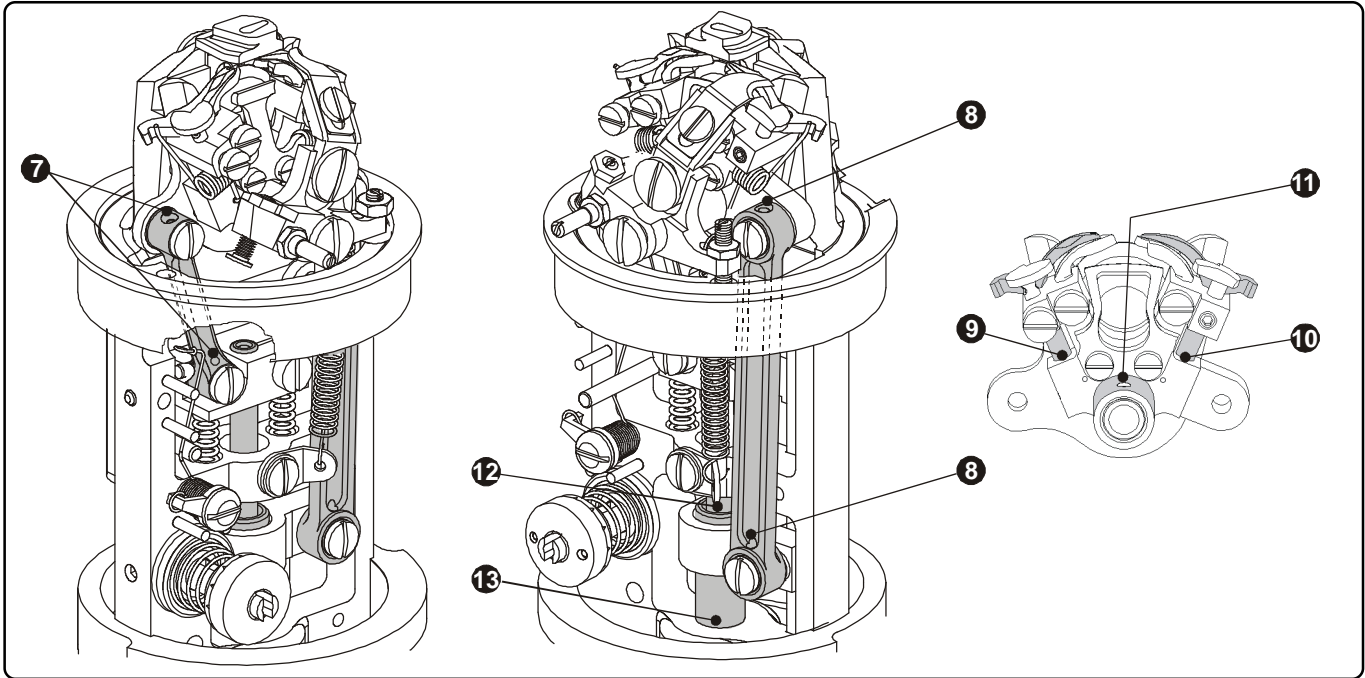

- 4.6. Remove the side covers, unscrew the screws **16** and loosen the screws **17**. Apply several drops of oil on the side edges of the clamp feet closing levers and to the marked lubrication holes **14**.
- 4.7. After lubrication it is important to sew a minimum 10 buttonholes on scrap fabric to dispel any excess oil. Wipe all visible excess oil from the mechanism in the work area.
- 4.8. Reassemble all removed parts, fix the feet plates again.
- 4.9. To lubricate the adjustable cutting length steel, remove the clamp plates and apply one drop of oil on the screw and on the screw bearing.

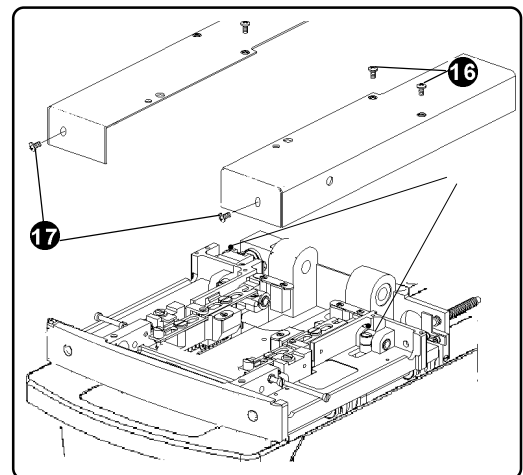

## F - MACHINE MAINTENANCE

---

### 5. MACHINE DISPOSAL

- 5.1. To ensure machine ecological disposal it is necessary to remove especially nonmetallic parts from the machine. To take these parts out, it is necessary to perform the partial dismantling of the machine, remove covers, dismantle the machine arm and remove the frame.
- 5.2. Aluminium and duralumin parts must be treated separately, also nonferrous metal parts and plastic parts.
- 5.3. Parts mentioned in point 2 can be found in the spare parts manual with these marks:
  - aluminium parts
  - non-ferrous metal parts
  - plastic and non-metallic parts

# G - DOCUMENTATION

## FLOW DIAGRAM

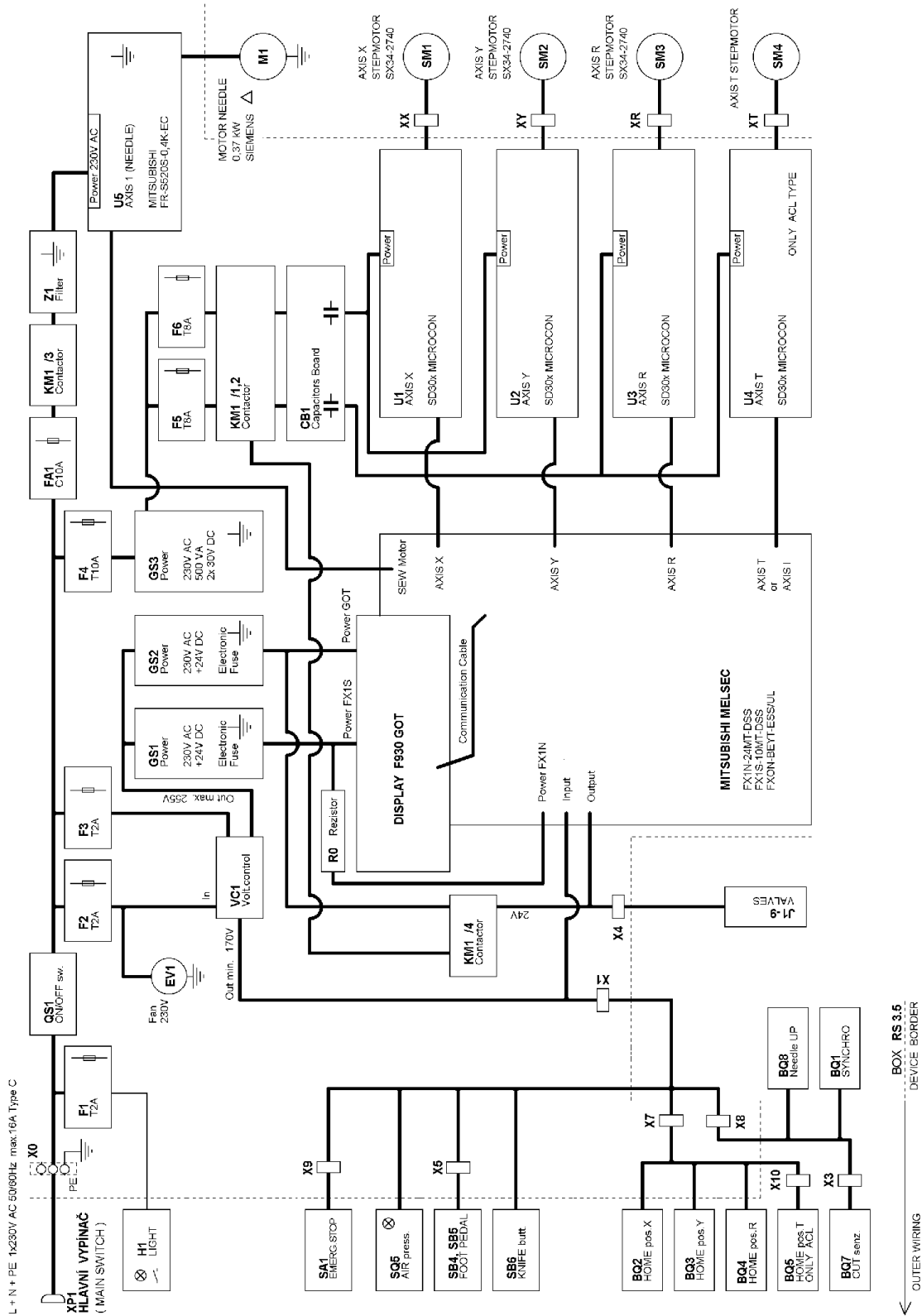

# MODEL S-311+I

## OPERATING INSTRUCTIONS



Revised 11/2006

E-mail: [service@amfreece.cz](mailto:service@amfreece.cz); [parts@amfreece.cz](mailto:parts@amfreece.cz); website: [www.amfreece.com](http://www.amfreece.com)

Phones: +420 582 309 146 (Service), +420 582 309 286 (Spare Parts); Fax: +420 582 360 606



## TABLE OF CONTENTS

---

<b>A - INTRODUCTION .....</b>	<b>1-1 I</b>
<b>1. GENERAL INFORMATION .....</b>	<b>1-1 I</b>
<b>2. SAFETY LABELS AND EQUIPMENT DEVICE .....</b>	<b>1-2 I</b>
<b>3. SPECIFICATIONS .....</b>	<b>1-3 I</b>
<b>C - PROPER USAGE .....</b>	<b>1-4 I</b>
<b>1. SETTING MACHINE INTO HOME POSITION TO START SEWING .....</b>	<b>1-4 I</b>
<b>2. THREADING .....</b>	<b>1-5 I</b>
<b>D - MACHINE FUNCTIONS CONTROLS .....</b>	<b>1-9 I</b>
<b>1. BUTTONHOLE SEWING .....</b>	<b>1-9 I</b>
<b>2. SETTING THE INDEXER DISPLAY .....</b>	<b>1-10 I</b>
<b>3. SETTING A BUTTONHOLE TYPE .....</b>	<b>1-11 I</b>
<b>4. SETTING A DISTANCE BETWEEN BUTTONHOLES .....</b>	<b>1-11 I</b>
<b>5. ERROR MESSAGES .....</b>	<b>1-12 I</b>
<b>E - STANDARD INDEXER ADJUSTMENT .....</b>	<b>1-13 I</b>
<b>1. SETTING CLAMP FEET HEIGHT .....</b>	<b>1-13 I</b>
<b>2. SETTING MINIMUM PLAY BETWEEN INDEXER FEET         AND CLAMPING MAT .....</b>	<b>1-14 I</b>
<b>3. SETTING A DISTANCE BETWEEN CLAMPING FEET .....</b>	<b>1-15 I</b>





## A - INTRODUCTION

---

### 1. GENERAL INFORMATION

The electronic eyelet buttonhole machine with Indexer enables automatic sewing of buttonholes which can be specified in number and distance between them. Typ stehu, odkaz na modely

#### Models of S-311 Indexer machine:

##### a) AF ST JT

This model is designed to be used for sewing single thread chain stitch buttonholes on ready-tailored jacket sleeves. The device enables sewing of various buttonhole types (see S311 section A, chapter 4 Specifications) with or without cut during one sewing cycle. There is a thread nipper attached to the device, which facilitates better quality of finished buttonholes.

Buttonholes commonly used on jackets sleeves:

- buttonhole with an eye
- with cut or without cut
- crossbar or round end

##### b) CT 16-20mm DT JT

This model is designed to be used for sewing double thread chain stitch buttonholes on ready-tailored jacket sleeves. The device enables sewing of various buttonhole types (see S311 section A, chapter 4 Specifications) with or without cut during one sewing cycle. There is a thread nipper attached to the device, which facilitates better quality of finished buttonholes.

Contrary to the version S311 AF ST JT the length of a buttonhole is limited for sewing within the range of 16-20 mm

Buttonholes commonly used on jackets sleeves:

- buttonhole with an eye
- with cut or without cut
- crossbar or round end

##### c) CT 16-20mm DT JS

This model is designed for sewing double thread chain stitch buttonholes with gimp on trousers or jeans front sections. The device enables sewing of various buttonhole types (see S311 section A, chapter 4 Specifications) with or without cut during one sewing cycle. Contrary to the version S311 AF ST JT the length of a buttonhole is limited for sewing within the range of 16-20 mm

Buttonholes commonly used on trousers front sections:

- buttonhole with an eye
- with cut
- flybar buttonhole

<b>ABBREVIATIONS USED IN THE MANUAL</b>	
<b>AF</b>	Adjustable flybar
<b>CT</b>	Cord trim - trimming all threads - short tail of bottom thread
<b>ST JT</b>	Single thread chain stitch - used on jackets
<b>DT JT</b>	Double thread chain stitch - used on jackets
<b>DT JS</b>	Double thread chain stitch - used on jeans (trousers)

## A - INTRODUCTION

---

### 2. SAFETY LABELS AND EQUIPMENT

For detailed description, see S-311 (section A, chapter 2, pages 1-2, 1-3).

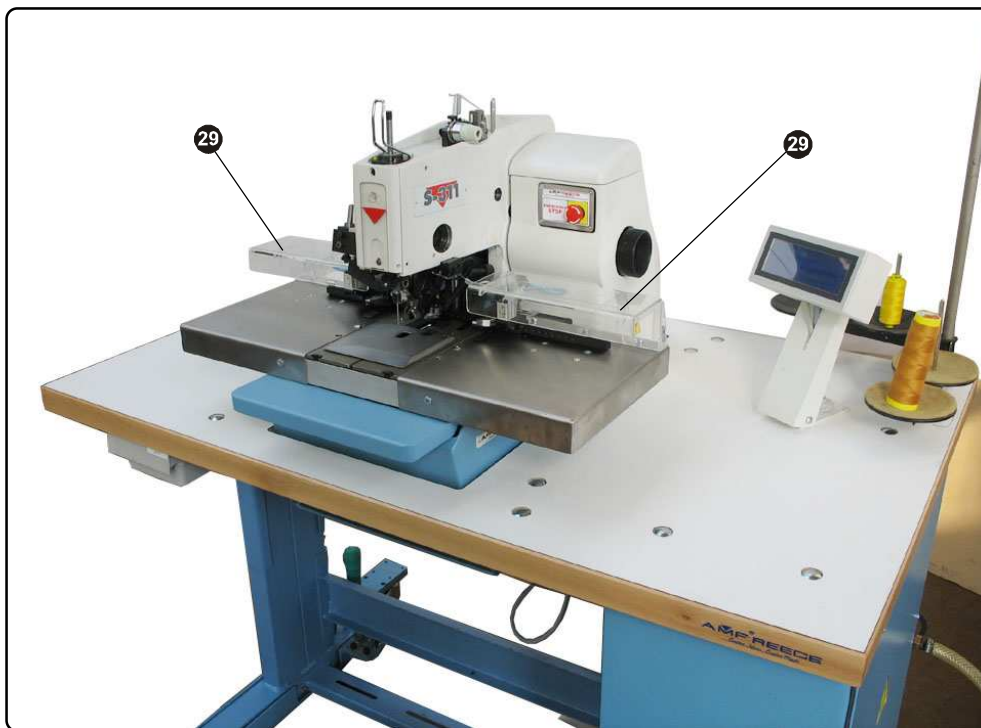





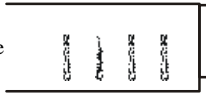
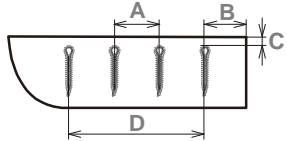
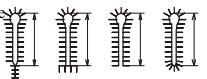
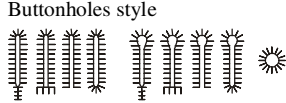

29 Indexer

## A - INTRODUCTION

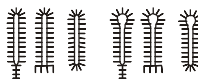
### 3. SPECIFICATIONS

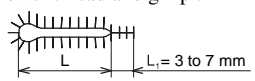
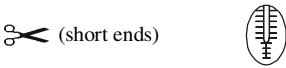
#### S-311+I

Machine models	AF ST JT	CT 16 - 20 mm DT JT	CT 16 - 20 mm DT JS
Application	Jacket Sleeve		Jeans Fly Front
Stitch Type	Single chainstitch	Double chainstitch with or without gimp	
Number of Buttonholes	1 - 8 buttonholes		
Distance between Buttonholes	8 - 160 mm <span style="float: right;">A</span>		
Distance from Fabric Edge (horizontal)	31 mm <span style="float: right;">B</span>		
Distance from Fabric Edge (vertical)	9 - 19 mm <span style="float: right;">C</span>		
Max. Horizontal Feed Amount	160 mm <span style="float: right;">D</span>		
			
Thread Nipper	Yes		No
Sewing Speed	1000 - 2000 stitches/min (500 - 1000 rev/min of the drive shaft)		
Buttonholes Length 	10 - 50 mm	16 - 20 mm	
Stitch Density	0,5 to 2,0 mm (increments of 0,1 mm)		
Number of Stitches in the eye	4 to 20		
Stitch Bite	2,1 mm (± 0,3 mm electronic adjustment); 2,7 mm (± 0,3 mm electronic adjustment)		
Buttonholes style 			
Eye type	No Eye; 2,2 x 3,0 mm; 2,8 x 4,2 mm; 3,0 x 4,6 mm; 3,2 x 5,0 mm; 3,4 x 4,2 mm		
Fly Bar Length	3,0 - 20,0 mm	See section D 3.3 - manual S-311	
Length of Crossbar	4 - 8 mm	4-6 mm	
Crossbar density	0,5 - 1,5 mm	0,5-1,5 mm	
Number of Stitches in the round end	4 to 20	—	
Clamp Foot Height	12 mm		
Sewing Thickness	in 8,0 mm		
Buttonhole Cutting	Cut before (CB), cut after (CA), no cut (OFF)		
Cutting Space	- 0,50 to + 1,2 mm		
Cut position (Y axis)	± 1,5 mm		
Bedplate movement	64 mm		
Needle system	02.0558.0.111 (Nm 100)	02.0558.1.112 (Nm 110)	
Recommended threads*	80, 100, 120, gimp size 30.		
Upper thread trimming 			
Lower thread and gimp trimming 	—		
Cutting space 	L = 16 to 20 mm L+L <sub>1</sub> = 23 to 27 mm		
Operating Condition	According to IEC 364-3, IEC 364-5-51 temperature from +5°C do 40°C, relative air humidity from 30 to 80%		
Air pressure	0,55 MPa = 80 PSI		
Machine db Level	L <sub>WA</sub> = 86,9db; L <sub>PA</sub> = 74,8 db; Noise measurement according to EN ISO 3746:1995		
Machine Head Dimension	530 mm (height) x 370 mm (width) x 560 mm (depth)		
Machine Head Weight	64 kg		
Table Dimensions	730 mm (height) x 1100 mm (width) x 700 mm (depth) + 150 mm distance		
Machine Weight	180 kg		
Electrical requirements	1NPE~60Hz 230 V/TN/S; 1NPE~50Hz 230 V/TN/S		
Line Circuit Breaker	Min. 10A Characteristic C (EN60947-2)		

\* **Note:** If a customer uses thread size 100 and less, the manufacturer recommends to use the left looper 17.0069.4.019  
If you use poor quality threads on the machine, the thread can burn at the needle (producer recommend decrease machine's speed).

Revised 11/2006

E-mail: [service@amfreece.cz](mailto:service@amfreece.cz); [parts@amfreece.cz](mailto:parts@amfreece.cz); website: [www.amfreece.com](http://www.amfreece.com)

Phones: +420 582 309 146 (Service), +420 582 309 286 (Spare Parts); Fax: +420 582 360 606

## C - PROPER USAGE

### 1. SETTING MACHINE INTO HOME POSITION TO START SEWING

- 1.1. Turn the switch clockwise to the position **I** to switch it on.
- 1.2. The display is activated and illuminated. The screen **⑥** displaying information of the manufacturer and numbers of programs uploaded in the machine appears. Wait until the main screen **③** appears on the display.
- 1.3. If **E01** error message is shown in the box **④** on the display (the machine is not in the home position), press the button  **⑤**. If another error message occurs, see the section *Troubleshooting*.
- 1.4. The machine is ready to start operation once the **Ready** message on the display in the box **④** is on. (*Display description on page 1-24, S-311*).
- 1.5. If you wish to operate the machine in the Indexer mode, follow the instructions in section D, chapter 2. Setting Indexer Display, page 1-10 I.

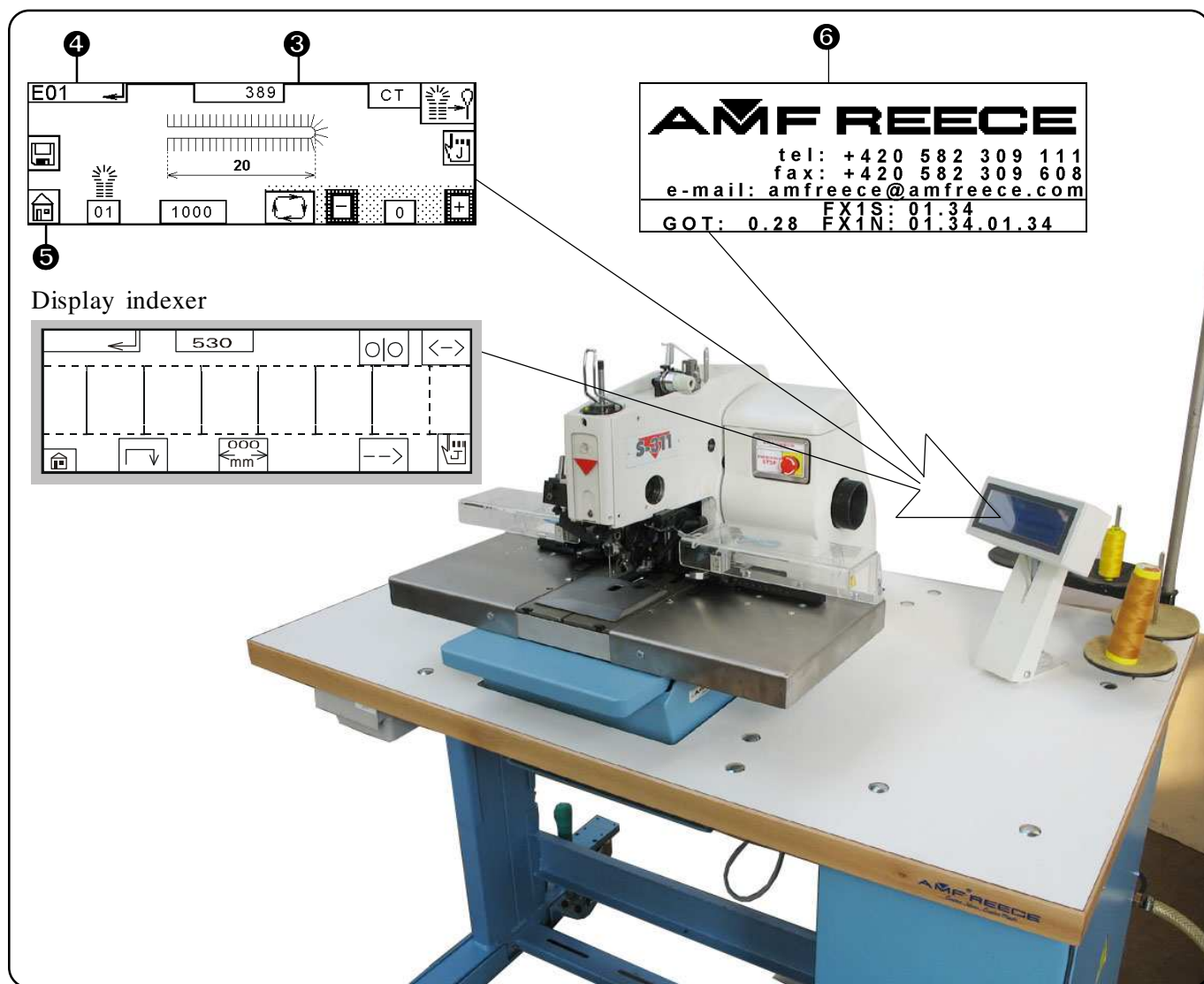

Revised 11/2006

E-mail: [service@amfreece.cz](mailto:service@amfreece.cz); [parts@amfreece.cz](mailto:parts@amfreece.cz); website: [www.amfreece.com](http://www.amfreece.com)

Phones: +420 582 309 146 (Service), +420 582 309 286 (Spare Parts); Fax: +420 582 360 606

## C - PROPER USAGE

### 2. THREADING

Threads are threaded as shown in the pictures below. For easy threading use threading device ❶ from the machine accessory. Threading device ❷ can be ordered separately (order number 12.0008.6.200). Thread tension can be adjusted with nuts ❸, ❹ according to sewing conditions as needed.

#### 2.1. Upper thread threading

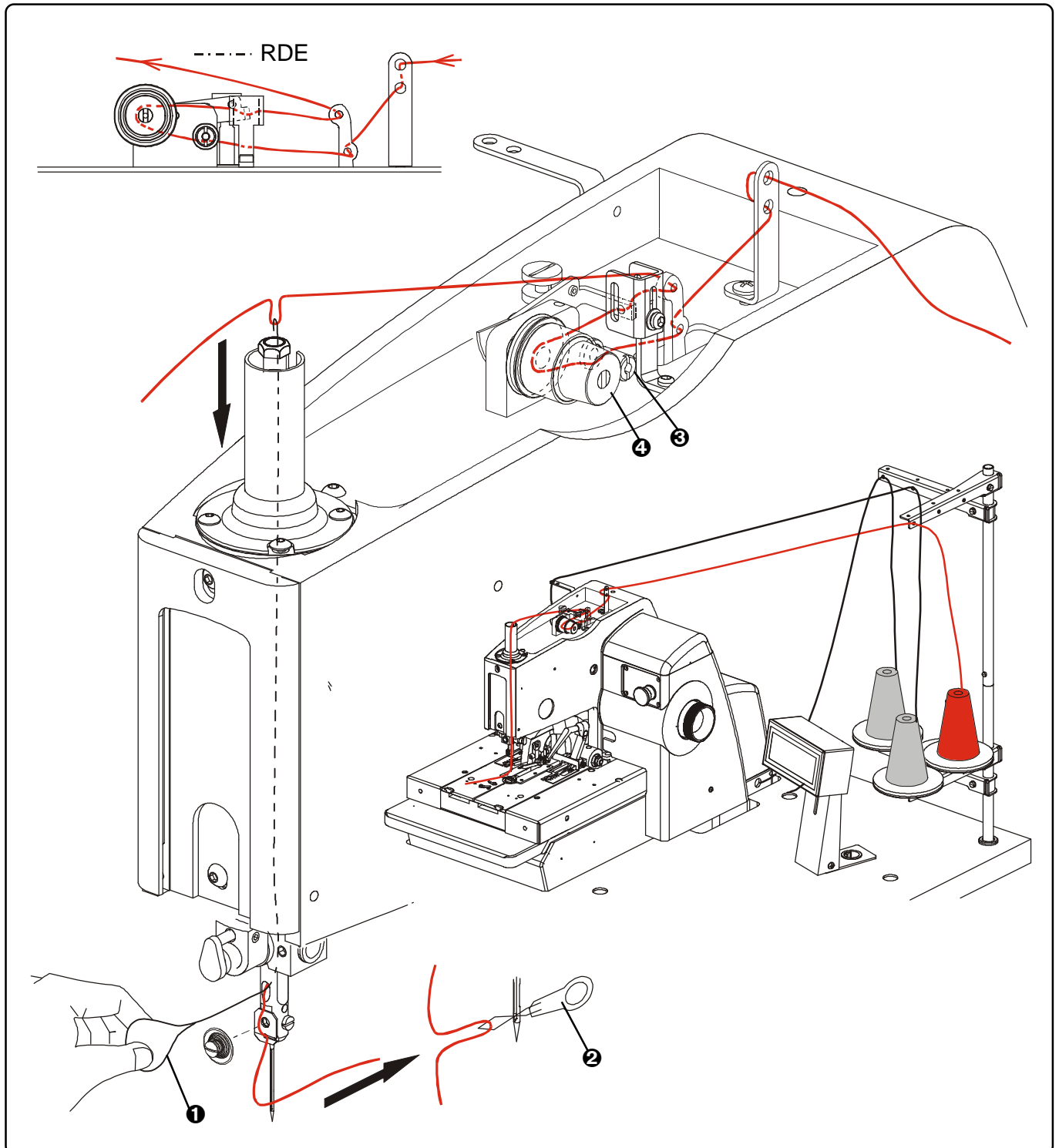

Revised 11/2006

E-mail: [service@amfreece.cz](mailto:service@amfreece.cz); [parts@amfreece.cz](mailto:parts@amfreece.cz); website: [www.amfreece.com](http://www.amfreece.com)

Phones: +420 582 309 146 (Service), +420 582 309 286 (Spare Parts); Fax: +420 582 360 606

## C - PROPER USAGE

### 2.2. Lower thread threading

— can be done after tilting the back cover ❶ and lifting the machine arm ❷.

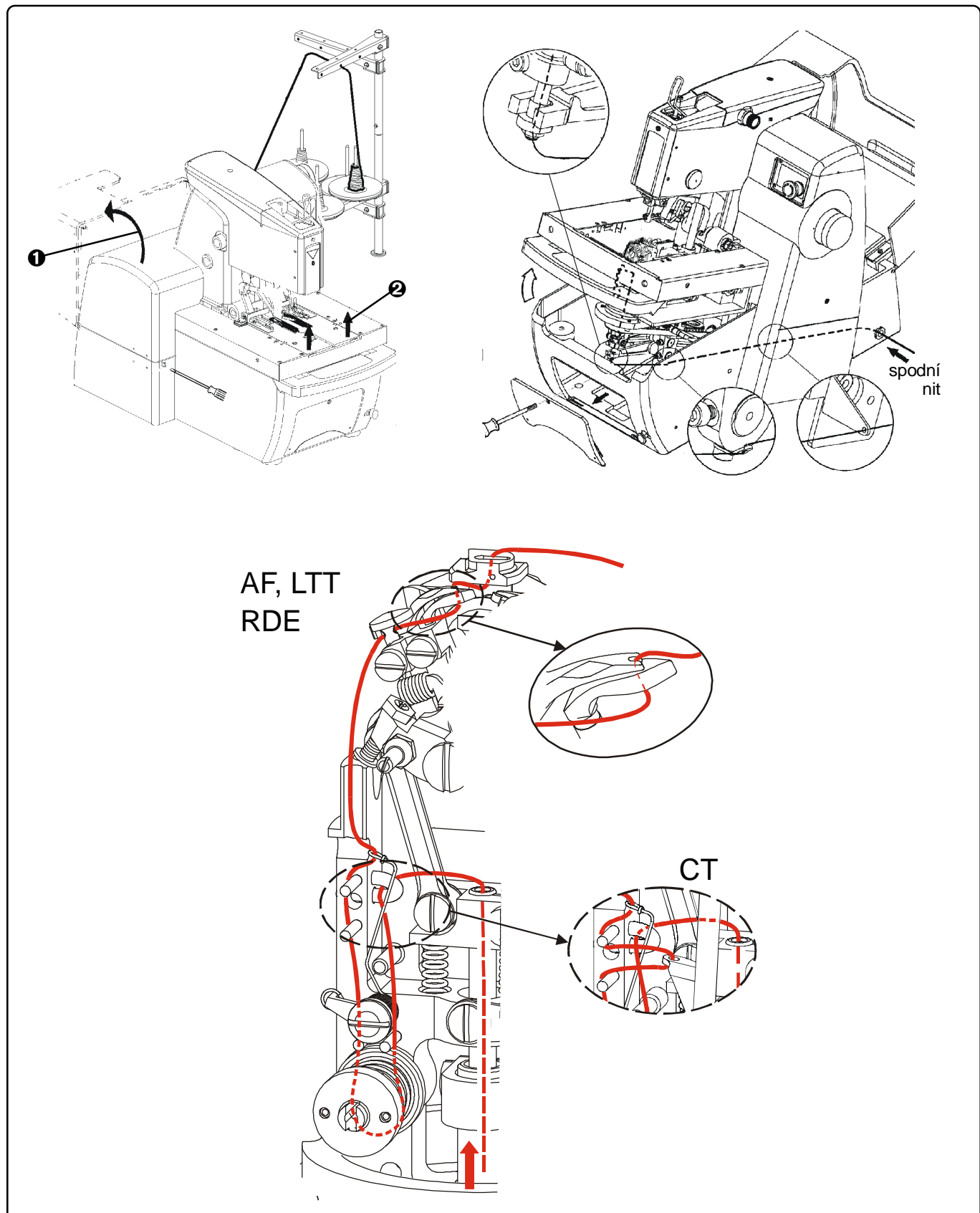

Revised 11/2006

E-mail: [service@amfreece.cz](mailto:service@amfreece.cz); [parts@amfreece.cz](mailto:parts@amfreece.cz); website: [www.amfreece.com](http://www.amfreece.com)

Phones: +420 582 309 146 (Service), +420 582 309 286 (Spare Parts); Fax: +420 582 360 606



## C - PROPER USAGE

### 2.3. Threading the machine S-311 CT+I

If you thread lower thread or gimp for the first time, it is necessary to dismantle the Indexer.

- a) Loose screws and remove safety covers ❶.
- b) Disconnect air pipes from cylinders.
- c) Loose screws ❷ of the right side feet holder and take it out.
- d) Hold the device ❸ and pull it to the left to take it out.
- e) Remove the clamp plates ❹ and thread lower thread or gimp.
- f) Mount the mechanism back into the machine.

**Note:** When assembling the right clamp foot, it is necessary to keep minimal distance of 0,5 mm. See section E, chapter 1.  
If the lower thread has just slipped out of the stitching plate, loose the screw ❺ and remove the clamp feet cover ❻.

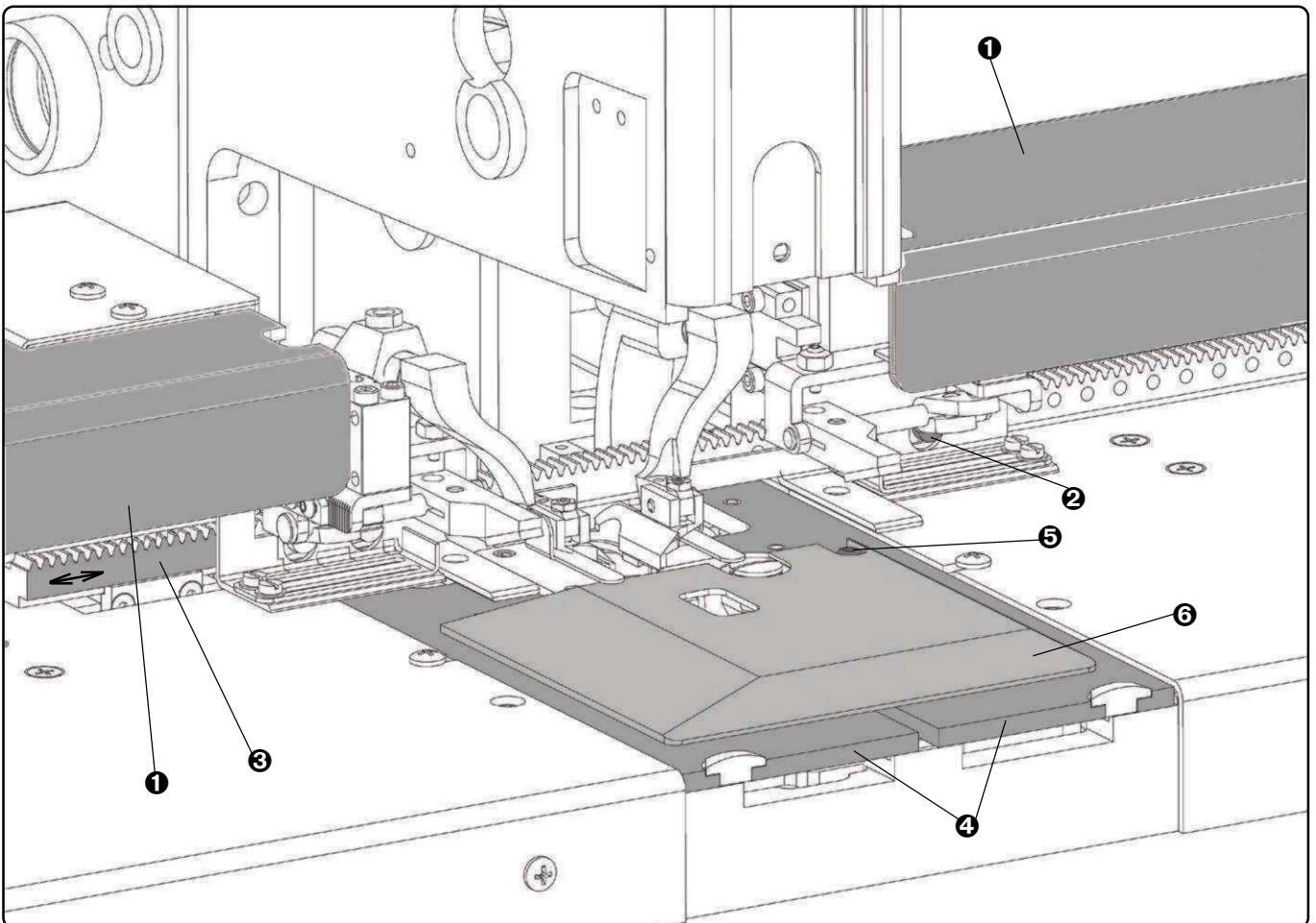

Revised 11/2006

E-mail: [service@amfreece.cz](mailto:service@amfreece.cz); [parts@amfreece.cz](mailto:parts@amfreece.cz); website: [www.amfreece.com](http://www.amfreece.com)

Phones: +420 582 309 146 (Service), +420 582 309 286 (Spare Parts); Fax: +420 582 360 606

## C - PROPER USAGE

### 2.4. Gimp threading

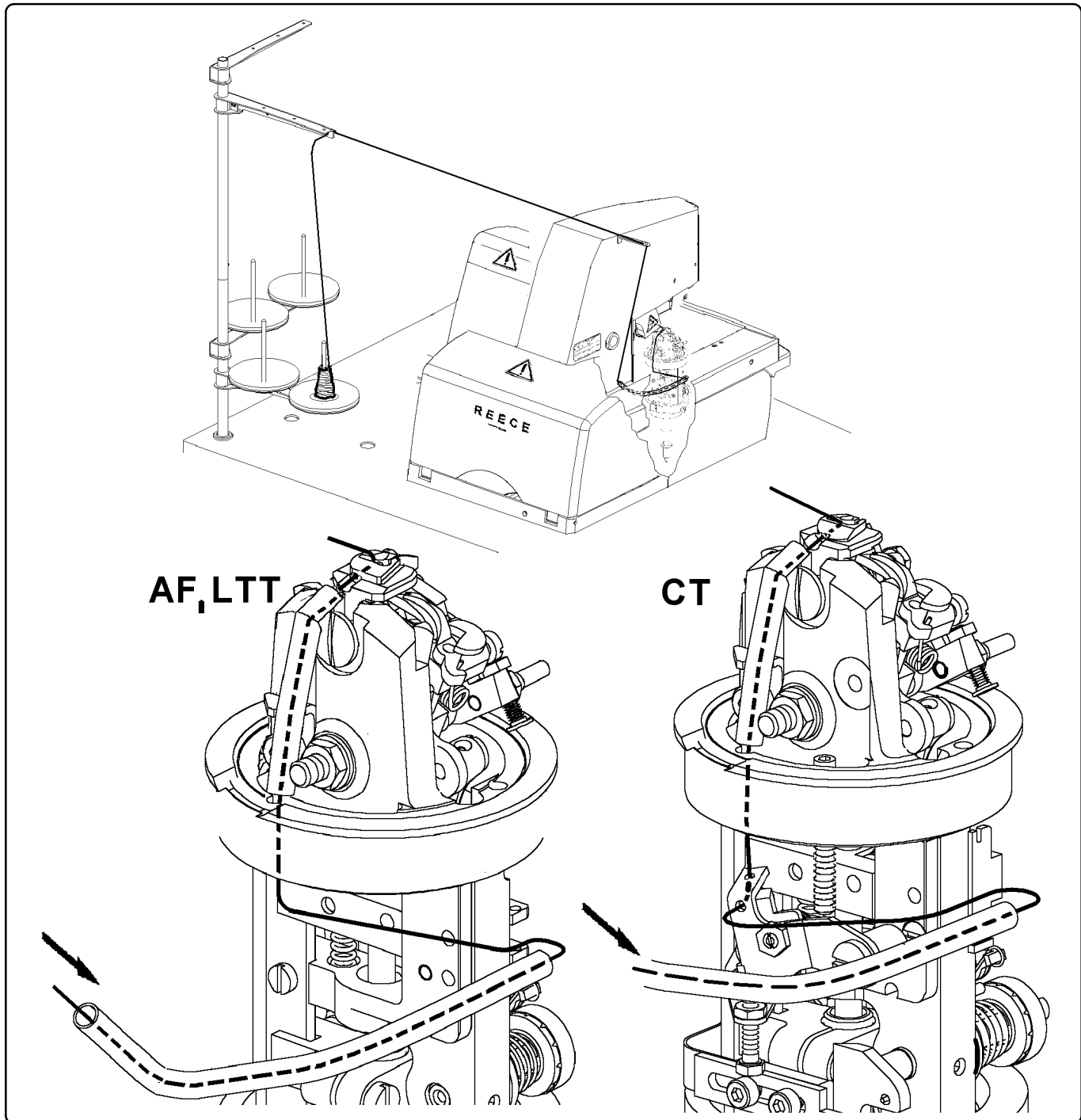

*The appearance and quality of the buttonhole may be affected by one or more of the following:*

- stitch density ( number of stitches in the first and the second row of stitches)
- number of stitches in the eye
- amount of fabric spread
- cutting space
- tension of upper and lower thread
- type of thread (size, etc.)
- needle bite
- sewn material (thickness, density)

Revised 11/2006

E-mail: [service@amfreece.cz](mailto:service@amfreece.cz); [parts@amfreece.cz](mailto:parts@amfreece.cz); website: [www.amfreece.com](http://www.amfreece.com)

Phones: +420 582 309 146 (Service), +420 582 309 286 (Spare Parts); Fax: +420 582 360 606



## D - MACHINE FUNCTIONS CONTROLS

### 1. SEWING A BUTTONHOLE

1.1. Set the machine into the home position as in section C1 of this chapter. Before starting sewing, let the machine warm up in this condition for about 3 minutes.

1.2. Check, if threads are correctly threaded as indicated in section C3, and place the work piece under the machine clamps. Correct placement of the buttonhole on the work piece will facilitate front stopper ❶ and side stopper ❷ that have adjustable lengths.

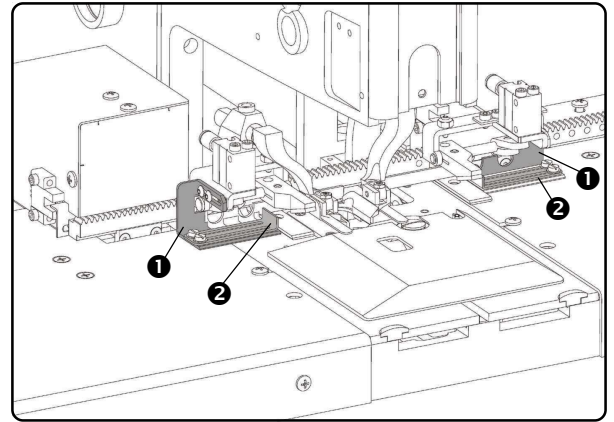

1.3. Pressing slightly the foot pedal into the first position will activate clamping and the work piece will be clamped. (Releasing the foot pedal will lift the clamps up again).

1.4. Pressing the foot pedal down (into the second position) will start sewing the buttonhole, which has been selected in the program. Once the buttonhole is sewn, fabric cut and upper thread trimmed, the clamps go up and the machine comes back into the home position.

1.5. Once the clamps are lifted up, it is possible to move the work piece in order to sew another buttonhole. If the Indexer device is activated, the fabric is moved automatically.

1.6. The machine can be stopped by the button STOP ❸ which is located on the machine arm, at any phase of the cycle. Releasing this button will stop the machine (Error E01, see section *Troubleshooting*).

1.7. Once sewing finished, switch the machine off. We also recommend unplugging the power cable from the socket and shutting the air supply off.

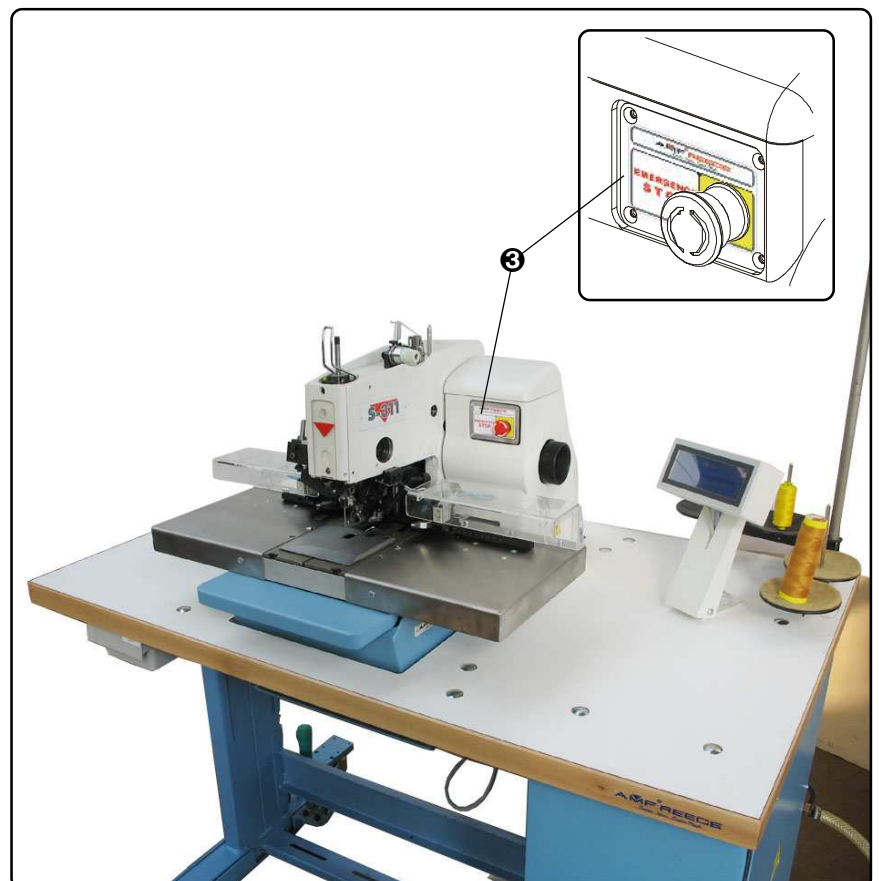

# D - MACHINE FUNCTIONS CONTROLS

## 2. SETTING UP THE INDEXER DISPLAY

If you change the display settings from S-311 to S-311 Indexer and vice versa, remember or note down all data.

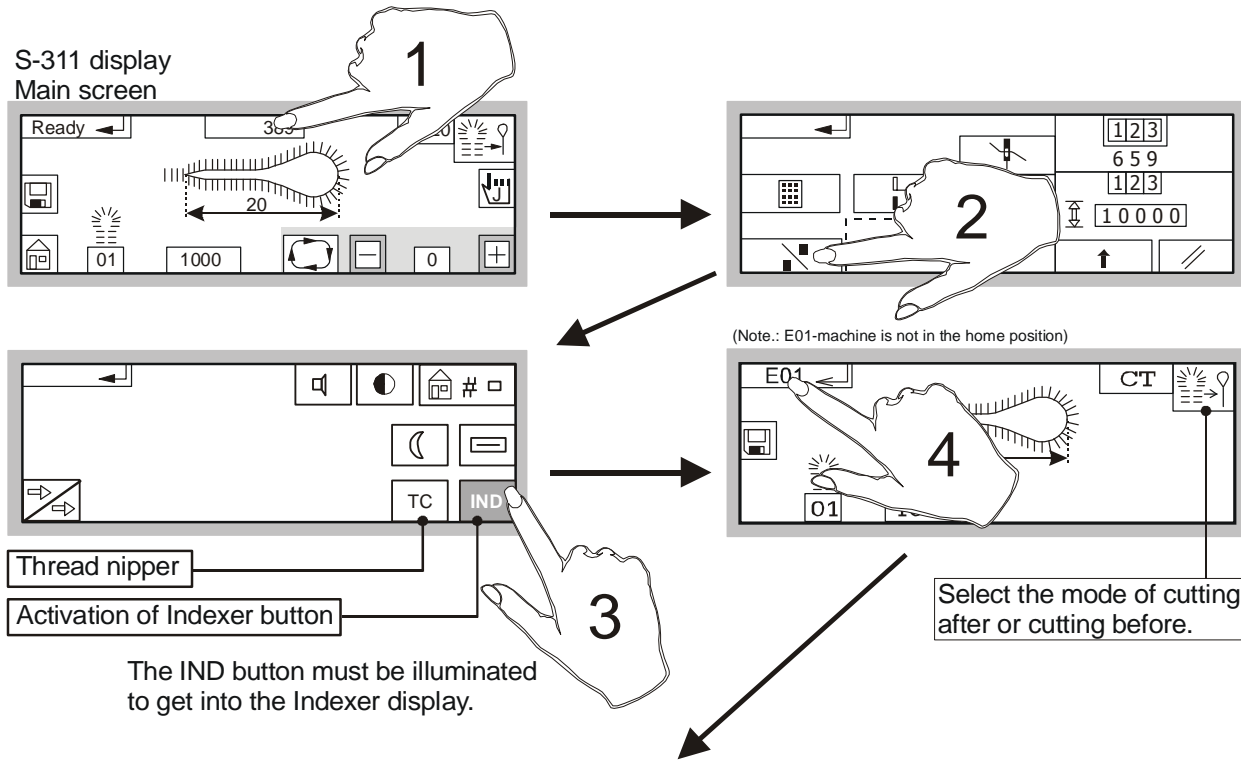

### S-311 INDEXER SCREEN

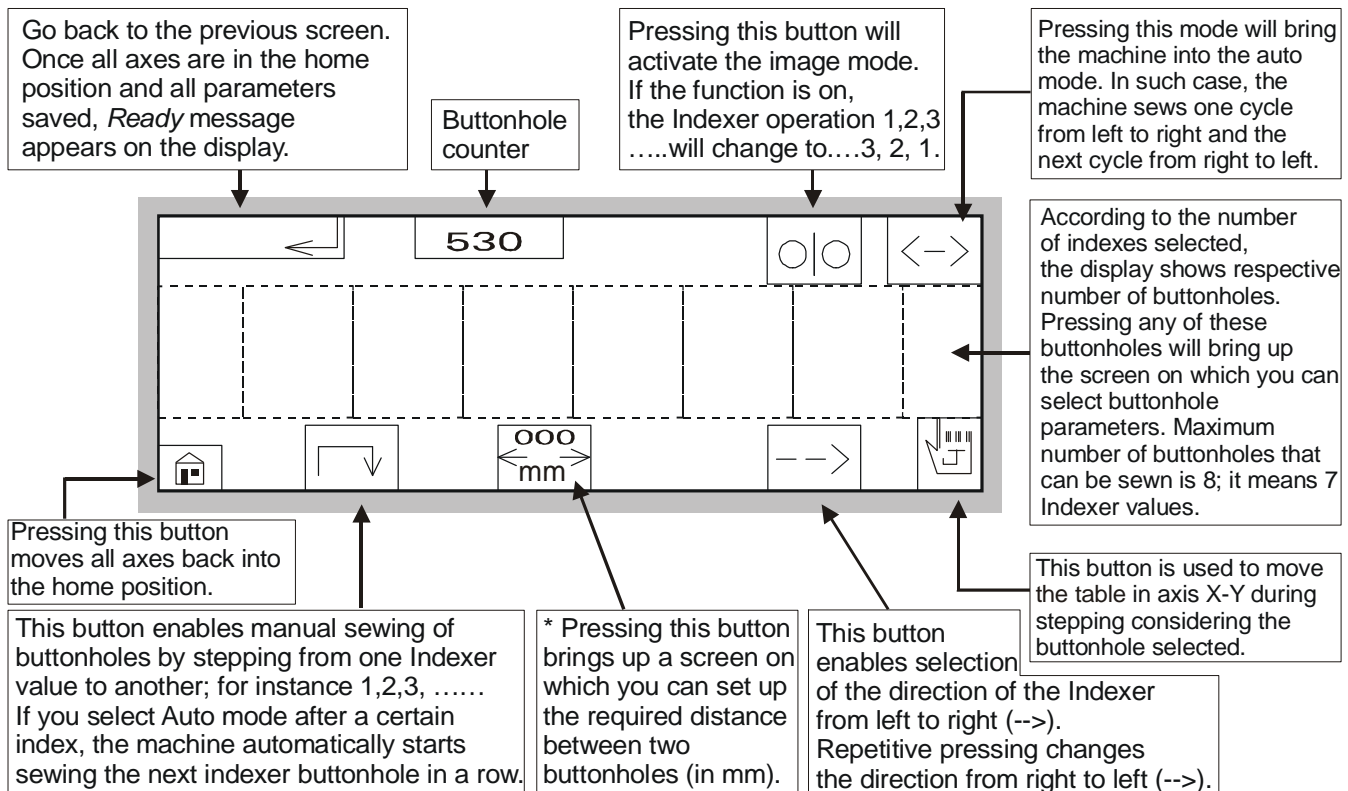

\* The maximal possible stroke of the Indexer is 160 mm. The combination must be selected considering the number of buttonholes to be sewn with the Indexer.

The minimal distance between two buttonholes is 7mm. It is a standard distance and has to be adjusted for required values.

## D - MACHINE FUNCTIONS CONTROLS

### 3. SETTING UP THE TYPE OF A BUTTONHOLE

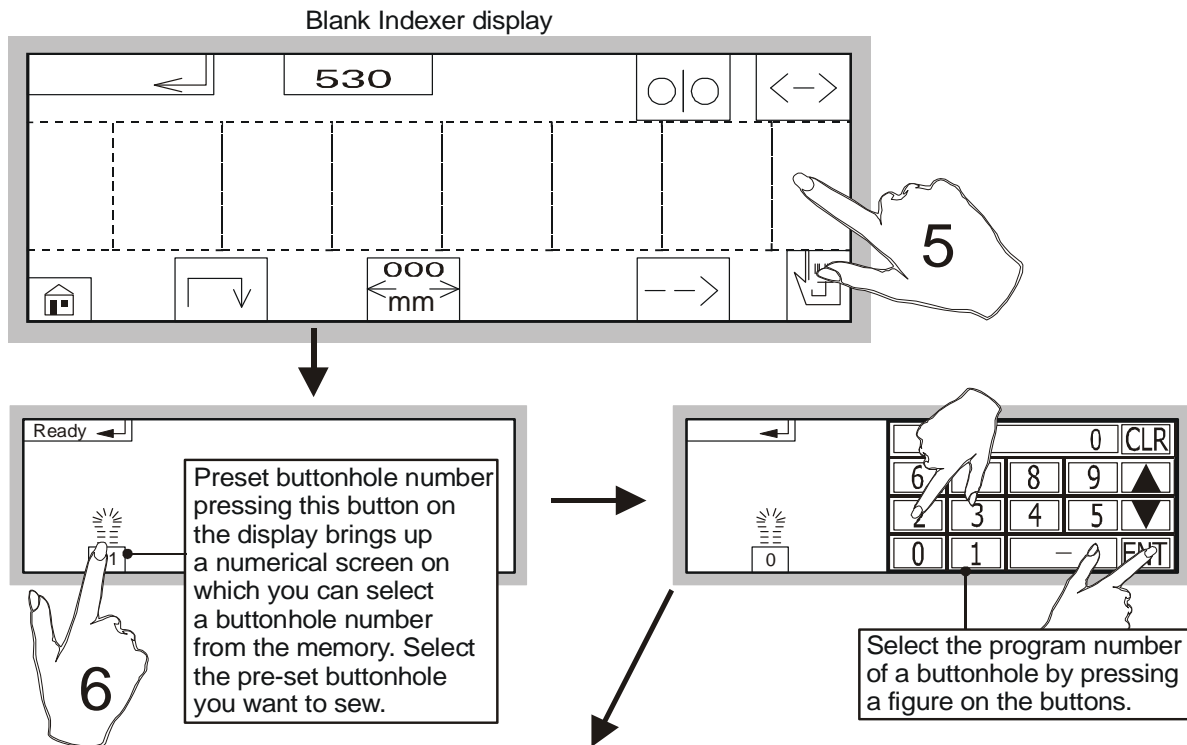

### 4. SETTING UP THE DISTANCE BETWEEN BUTTONHOLES

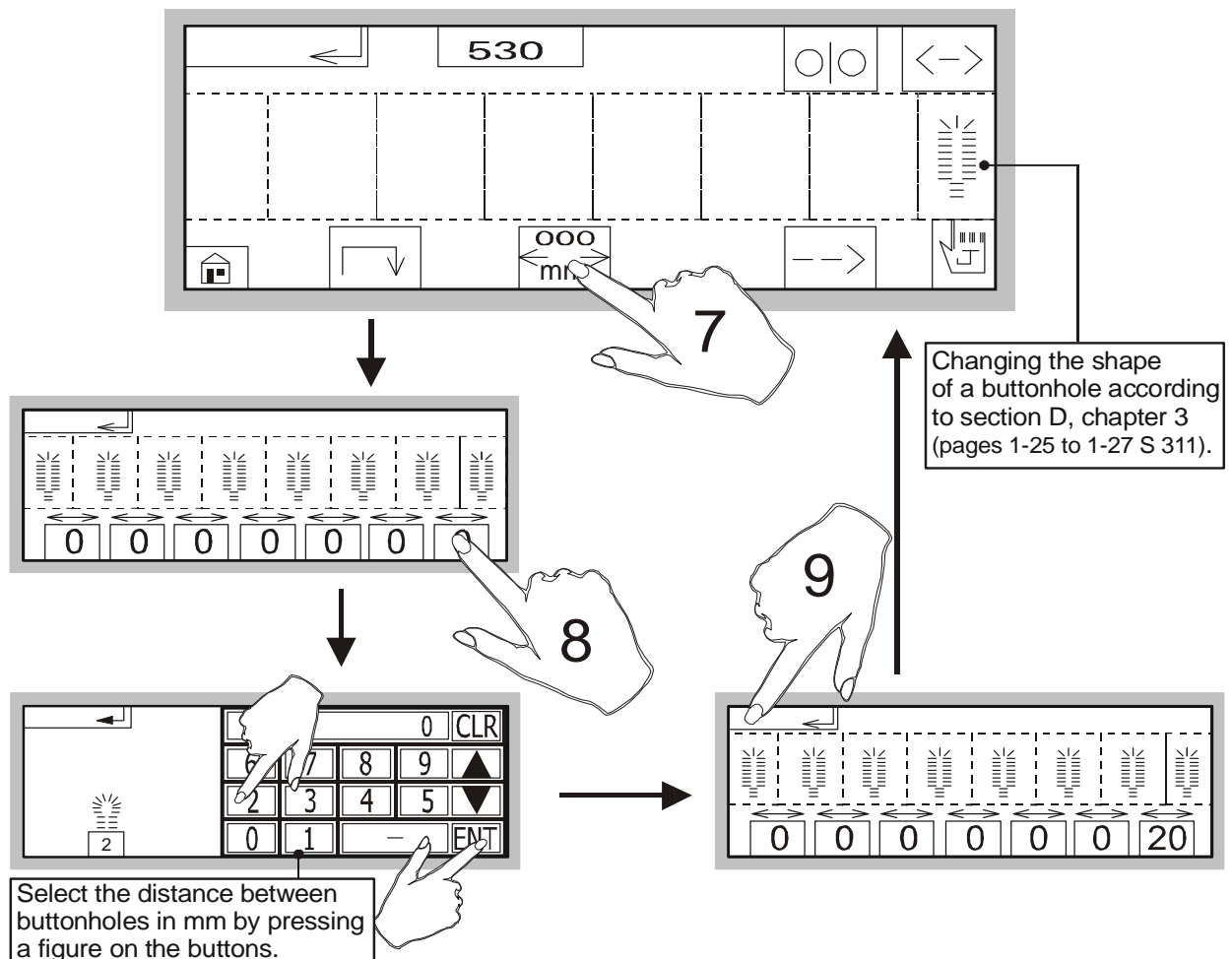

## D - MACHINE FUNCTIONS CONTROLS

---

After switching the machine off by the main switch and switching it on again, the screen that had been set before appears on the display.

Hidden parameters can be accessed only with the password 123.

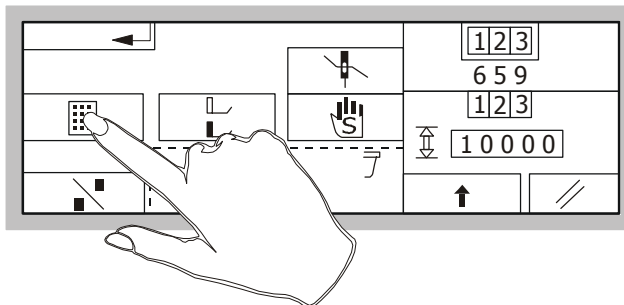

### 5. ERROR MESSAGES

5.1 If this symbol  appears on the display, the distance set between buttonholes is too high.

To access the screen “distance between buttonholes”, touch the screen twice (2x).

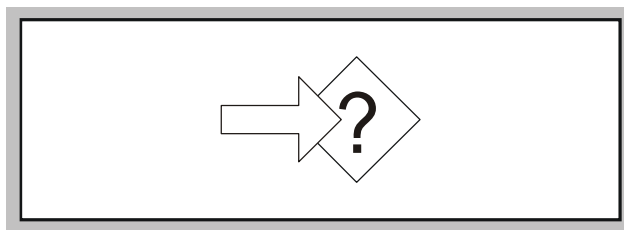

You have to start setting up required values from the standard distance of 7 mm again.

If you wish to sew larger distances between buttonholes, you have to set up larger distance between Indexer feet.

## E - STANDARD INDEXER ADJUSTMENT

### 1. SETTING UP THE HEIGHT OF CLAMPING FEET

In order for the Indexer to function correctly, it is important to set up correct height of Indexer clamping feet above the desktop.

- 1.1. Loose clamp holders screws **1** on the left and right side of the Indexer.
- 1.2. Set up a gap of 0,5 - 0,7 mm between feet and desktop (feeler gauge can be used).
- 1.3. Verify the setting by pressing the button . The device must move freely without stopping.
- 1.4. If the device stops, it is necessary to increase the gap between feet and desktop according to instructions in 1.1, 1.2.

**Note:** The above-mentioned adjustment is necessary every time you change the distance between the clamping feet according to the size of workpiece and number of buttonholes sewn.

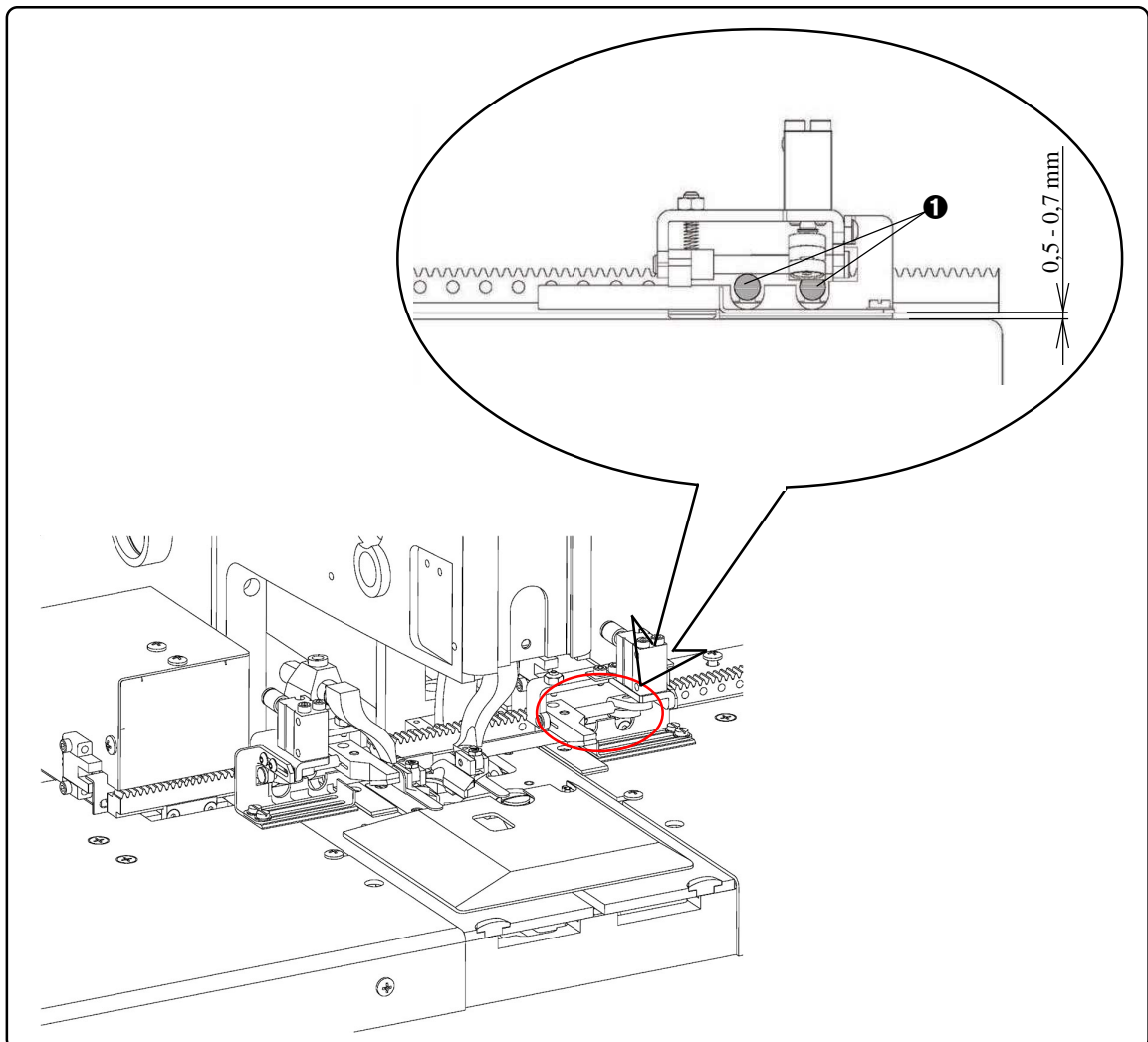

## E - STANDARD INDEXER ADJUSTMENT

### 2. SETTING UP MINIMAL PLAY BETWEEN INDEXER FEET ❶ AND CLAMPING MAT ❷

It is important to set up the minimal play between Indexer feet ❶ and clamping mat ❷ correctly so that the spreading mechanism on the sewing head operates correctly. It is necessary to hold the minimal play.

2.1. Check, whether the play on the machine is set onto 2mm in both positions of the Indexer. Use this display button  to make a move.

2.2. If the 2-mm distance is not adjusted on the machine, loose screws ❸ and move sensors ❹ into the required position. The distance increases in the direction of A and decreases in the direction of B.

2.3. Secure the setting by tightening screws ❸.

2.4. Check the setting by pressing the button . The device must move freely without stopping.

**Note:** If the distance is smaller than 2 mm, the fabric will not be properly stretched during sewing an eye!

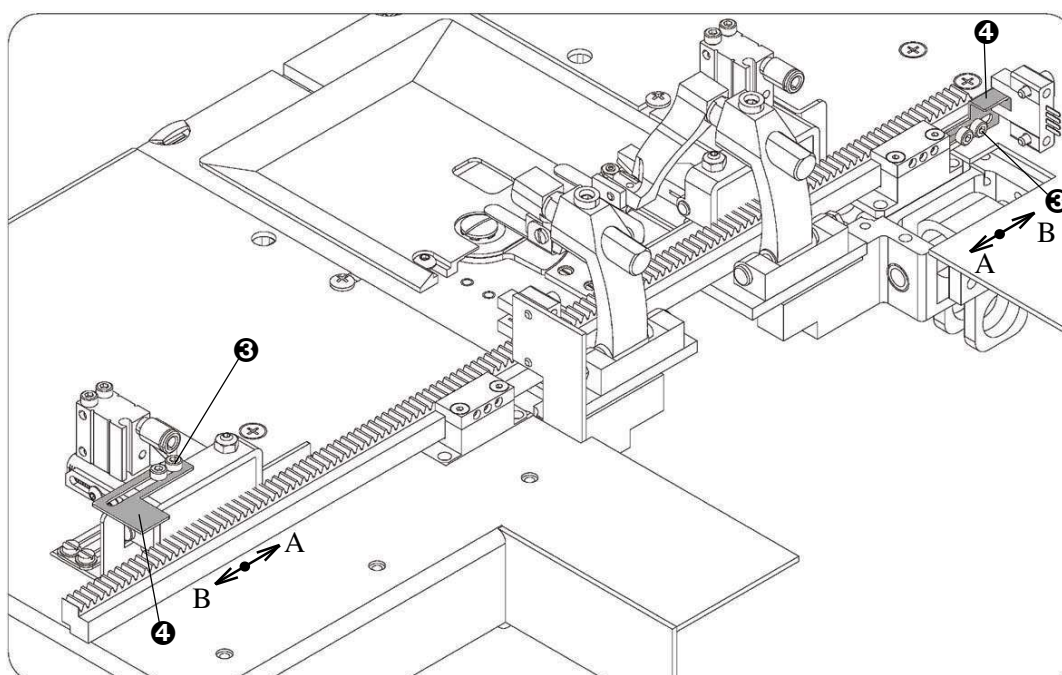
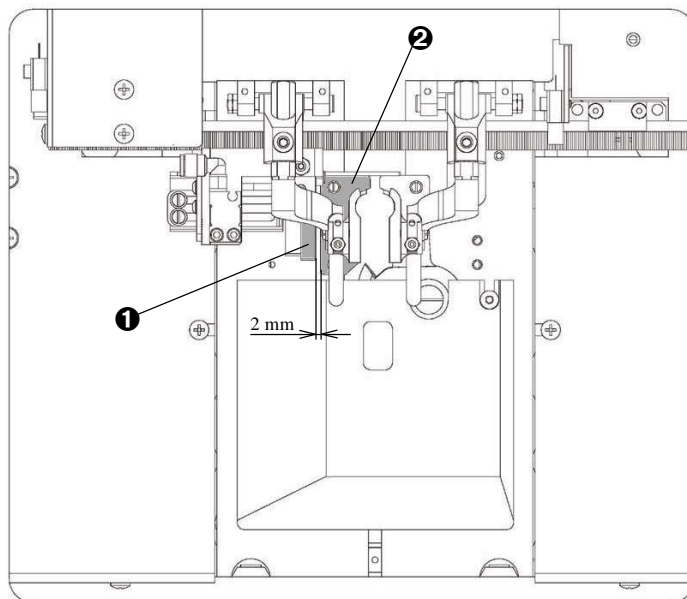

Revised 11/2006

E-mail: [service@amfreece.cz](mailto:service@amfreece.cz); [parts@amfreece.cz](mailto:parts@amfreece.cz); website: [www.amfreece.com](http://www.amfreece.com)

Phones: +420 582 309 146 (Service), +420 582 309 286 (Spare Parts); Fax: +420 582 360 606



## E - STANDARD INDEXER ADJUSTMENT

### 3. SETTING UP THE DISTANCE BETWEEN CLAMPING FEET

Change the distance between clamping feet ❶ if you want to change workpiece or number of buttonholes to be sewn.

3.1. Take out screws ❷ of the right holder ❸ and adjust the required distance X between the Indexer clamping feet ❶ and clamping mats ❹ of the sewing head feet.

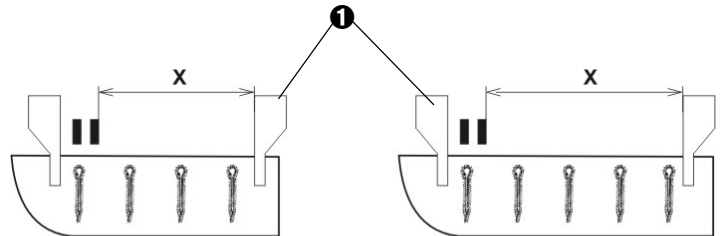

3.1.1. The minimal distance X can be found in display pre-set parameters.

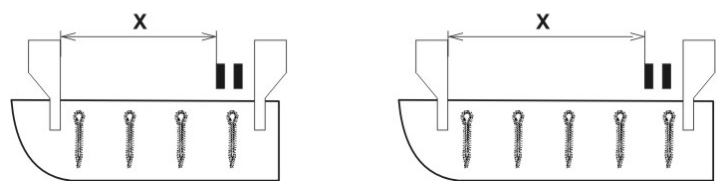

#### Example:

You wish to sew 4 buttonholes with the distance of 25 mm between them. The total length is 75 mm (the first buttonhole is always sewn in indexer home position).

$X = (\text{number of buttonholes} - 1 \text{ fixed in place}) \times \text{distance between them} + 2 \text{ mm}$  (minimal play between Indexer feet and clamping mat of the sewing head; see chapter 2).

$$X = (4-1) \times 25 + 2 = 77 \text{ mm}$$

Minimal distance must be adjusted to 77 mm.

If the minimal distance is shorter, the display signals an error message – the required operation cannot be performed.

3.2. Secure the correct position by screws. Do not forget to adjust the play between a clamping foot and desktop ( see chapter 1).

3.3. Check the setting by pressing the button . The device must move freely without stopping.

**Note:** Setting up the distance between clamping feet needs to be done always by changing the position of the right clamping foot of the Indexer only!

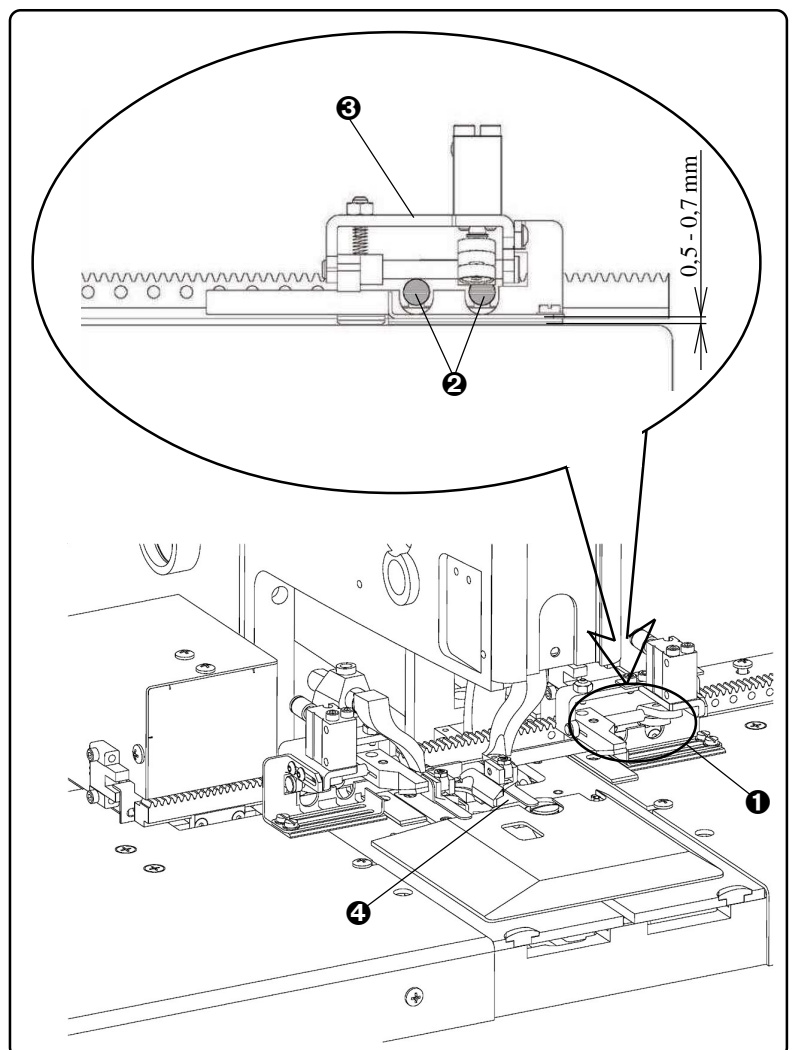





## TROUBLESHOOTING

---

### TABLE OF CONTENTS

	Page
1. INTRODUCTION .....	2-2
2. FAULTS WITHOUT ERROR MESSAGES .....	2-3
3. THE ELECTRONIC SYSTEM ERROR MESSAGES .....	2-5
4. ELECTRICAL FAULTS .....	2-6

Revised 03/2006

e-mail: [service@amfreece.cz](mailto:service@amfreece.cz); [parts@amfreece.cz](mailto:parts@amfreece.cz); website: [www.amfreece.com](http://www.amfreece.com)

Phones: +420 582 309 146 (Service), +420 582 309 286 (Spare Parts); Fax: +420 582 360 606

## TROUBLESHOOTING

---

**Warning!** Inspect the machine on a regular basis and use only quality parts. The manufacturer recommends using original AMF Reece parts, especially needles, loopers, spreaders, and throat plates.

### 1. INTRODUCTION

The **S211** electronically displays error messages, when worn or damaged parts are detected. If machine problems occur and the error is not displayed, ensure correct needle installation and threading. The other troubles are eliminated according to the detailed descriptions listed.

#### Adjustments Quick Reference List

**Note:** Required machine settings are variable according to the fabric and thread variations used. The type of thread and fabric will affect the amount of wear on machine parts. The components marked in yellow are set by manufacturer and do not require further adjustments. Changing the position of components marked in yellow, without the approval of the manufacturer, may cancel the warranty.

To obtain the highest quality buttonhole maintain the following values:

- clearance between the needle and the loopers is 0.05 to 0.1 mm, (0.002 to 0.004")
- clearance between the needle and the needle support is 0.05 to 0.1 mm.
- the same distance of the left spreader tip and the right spreader tip when they pass the needle.
- left looper on the centre of the needle when the stroke is 3.4 mm from the lowest position.
- with the needle bar in the lowest position, the axial clearance is 0.25 mm, (0.010") when the pressure power is 5N
- with the needle bar in the lowest position, the radial clearance is 0.05 mm, (0.002") when the pressure power is 5N
- looper holder axial clearance is 0.05 to 0.1 mm, (0.002 to 0.004").
- looper holder radial clearance is 0.1 to 0.2 mm (0.004 to 0.008").
- looper holder angular clearance is 1.2 on the arm 28.5 mm when the pressure power is 5N.
- distance between the flags and sensors BQ1, BQ2, BQ3, BQ8 to 0.5 mm on the sensor BQ4 to 0.3 mm.
- air pressure regulator set to 0.45 MPa.
- BQ1 is activated when the needle bar raises 22 mm above the lowest position
- BQ8 is activated when the needle bar raises 32 mm above the lowest position

Revised 03/2006

## TROUBLESHOOTING

### 2. FAULTS WITHOUT ERROR MESSAGES

SYMPTOM	POSSIBLE CAUSE	PROBABLE SOLUTION	SERVICE SECTION
Thread breakage.	Thread draw-off is too tight	Reduce thread tension.	<b>E12</b>
	Damaged loopers, spreaders, or throat plate.	Replace damaged parts.	
	Incorrect needle and sewing mechanism adjustment.	Correctly adjust the needle bar, loopers, openers and tension.	<b>E4,E10,E7, E11,E12</b>
	Poor thread quality.	Replace thread.	
	Thread holes in the needle and the looper are too small.	Use correct parts.	
The machine does not sew.	Bent or broken needle.	Roll the needle on a smooth flat surface, if bent, replace the needle.	
	Needle track on a looper.	Deburr or replace the looper.	
	Damaged throat plate.	Deburr or replace the throat plate.	
	Incorrect sewing system adjustment	Correctly adjust.	
Skip stitches.	Incorrectly adjusted thread draw-off.	Correctly adjust the sewing mechanism	<b>E12</b>
	Bent needle or damaged stitch forming parts.	Replace the damaged parts.	
	Incorrectly adjusted sewing mechanism.	Correctly adjust the sewing mechanism.	<b>E10,E11</b>
	Incorrect needle guard distance.	Set the distance to 0.05 mm.	
	Defective spreader return springs	Replace the springs.	
Sewn fabric is incorrectly cut.	Knife and cutting steel are incorrectly installed.	Check the knife impression on the cutting steel, adjust or replace as needed. Check the knife. Replace if damaged.	
	Cutting cylinder pressure is too low.	Tighten the adjusting screw by 1/2 rotation and check the cutting.	<b>B7</b>
Top thread is not trimmed.	Damaged knife.	Replace the knife.	
	Knife does not return.	Adjust or replace the spring.	
	Knife incorrectly installed.	Correctly install the knife.	<b>E13</b>

Revised 03/2006

e-mail: [service@amfreece.cz](mailto:service@amfreece.cz); [parts@amfreece.cz](mailto:parts@amfreece.cz); website: [www.amfreece.com](http://www.amfreece.com)

Phones: +420 582 309 146 (Service), +420 582 309 286 (Spare Parts); Fax: +420 582 360 606

## TROUBLESHOOTING

SYMPTOM	POSSIBLE CAUSE	PROBABLE SOLUTION	SERVICE SECTION
The lower thread is not caught in the thread retainer after sewing the buttonhole	Big clearance between the clamps of the holder	Adjust the clearance between the clamps for 0,05 mm	<b>E13</b>
The lower thread is trimmed, but is held in the looper	The thread retainer is adjusted incorrectly	Re-adjust the thread retainer	<b>E13</b>
Thread pick-up does not catch the upper thread	Knife for trimming the upper thread is damaged	Check the knife, re-adjust	<b>E13</b>
The lower thread is not trimmed	Check the shears on the clamp plate for dullness or damage	Grind or replace	
	Low air pressure	Set the air pressure to 0.45 MPa and higher	<b>B7</b>
Broken needle	Incorrectly set parameters for length of a buttonhole and flybar length	Length of a buttonhole and flybar length must be set in accordance with installed clamp plates	<b>D3</b>
	Loopers are incorrectly adjusted	Re-adjust	<b>E10</b>
	The shears on the clamp plate do not operate the right way	Check the shears, clean or lubricate	
The machine switched off when sewing the buttonhole	The power supply was disconnected	Switch the machine on and continue according to section <b>C1</b>	
When sewing the next buttonhole first stitches are loose	The top thread is loose	It is recommended to equipped the machine with the thread nipper for the following 03.5519.3.013	

Revised 03/2006

e-mail: [service@amfreece.cz](mailto:service@amfreece.cz); [parts@amfreece.cz](mailto:parts@amfreece.cz); website: [www.amfreece.com](http://www.amfreece.com)

Phones: +420 582 309 146 (Service), +420 582 309 286 (Spare Parts); Fax: +420 582 360 606

## TROUBLESHOOTING

### 3. THE ELECTRONIC SYSTEM ERROR MESSAGES

If an error message appears on the display (see picture ❶), press it. The screen with a description and a correction of an error message appears on the display (see picture ❷).

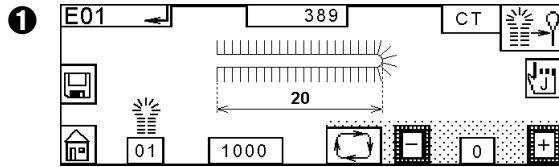

SYMPTOM	POSSIBLE CAUSE	PROBABLE SOLUTION
<b>E-01</b>	Axes are not home	Press  button to bring the machine to the home position
<b>E-02</b>	Needle is not in the upper position and the marks on the handwheel and the cover are not aligned.	Turn the handwheel to align marks. Ensure the needle is in the left position
<b>E-04</b>	Low air pressure. Air pressure is below 3,5 bar	Check the air supply
<b>E-06</b>	The cutting lever is not home.	Check BQ7 sensor and the air supply
<b>E-07</b>	Low voltage (if there is the relay VC1)	Check the power supply, voltage.
<b>E-10</b>	X axis error	Press  button
<b>E-11</b>	Y axis error	Press  button
<b>E-12</b>	R axis error	Press  button
<b>E-14</b>	ACL error	Press  button
<b>E-20</b>	Sew motor error	Check the frequency inverter
<b>E-40</b>	Service mode	Press and release the Emergency stop button and then  button
<b>E-61</b>	Not saved	Press  button
<b>E-99</b>	Emergency Stop button	Release the Emergency Stop button

## TROUBLESHOOTING

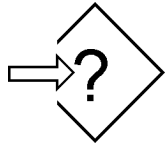

The length of the buttonhole and the length of a flybar is incorrectly set

Set correct length of a buttonhole and length of a flybar - see section **D3**. The total can not exceed 50.

### 4. ELECTRICAL FAULTS

SYMPTOM	POSSIBLE CAUSE	PROBABLE SOLUTION
When switch in position I, neither the work light or the cooling fan operate	No power supply	Check main power supply or voltage in the socket
	Fuse F1, F2 failure (T2A)	Replace fuse PN 12.0008.4.665
	Power switch QS1 damaged	Replace the switch 12.0008.4.835
	The supply voltage is above 255 V (red LED lights on relay VC1 — if there is the relay VC1)	Call electronic engineer in the plant
	Relay VC1 damaged	Replace the relay 12.0008.4.690
After the machine is switched on, display does not light	GS1, GS2 Power damaged	Replace the power 12.0008.4.709
	Cable from the display disconnected	Check the display connection
	Display or its control damaged	Replace display or control units, call AMF Reece Service
When sewing operation started, motor does not operate. Frequency inverter U5 error - check its display - does not light. Contactor KM1 switched on.	Fuse F4 failure (T10A)	Replace fuse PN 12.0008.4.664
	Frequency inverter U5 error or filter Z1 error	Call AMF Reece service
When sewing operation started, motor fails to operate. Frequency inverter U5 error - check its display - does not light. Contactor KM1 switched off.	Fuse F3 failure	Replace fuse PN 12.0008.4.063
	Contactor KM1 damaged	Replace contactor 12.0008.4.833
	Emergency stop turned off	Turn on emergency stop
	Defective emergency stop button	Change the stop button PN 12.0008.4.563
	Disconnected girth	Check the girth button

Revised 03/2006

e-mail: [service@amfreece.cz](mailto:service@amfreece.cz); [parts@amfreece.cz](mailto:parts@amfreece.cz); website: [www.amfreece.com](http://www.amfreece.com)

Phones: +420 582 309 146 (Service), +420 582 309 286 (Spare Parts); Fax: +420 582 360 606

## TROUBLESHOOTING

SYMPTOM	POSSIBLE CAUSE	PROBABLE SOLUTION
When sewing operation started, air valves do not operate. The air pressure correct.	Contactora KM1 damaged	Replace contactora 12.0008.4.833
	GS2 Power damaged	Replace the power 12.0008.4.709
Incorrect function of the air valves	Inadequate contact of contactora KM1, or sockets X4	Replace contactora 12.0008.4.833 Check the main power supply with socket X4
Stepping motors do not hold their position	Fuse F3 failure. (No LED light on CB1) (T10A)	Replace fuse PN 12.0008.4.664
Some part of one of the stepping motor does not keep its position	Driver error	Change the driver PN 12.0008.4.891
	Stepping motor supply is connected	Check a connection: motor - driver
	Stepping motor fault	Change motor
	Contactora KM1 fault. (No LED light on CB1 plate )	Replace contactora PN 12.0008.4.833
	Burned fuse F5, F6 (Just one LED light on CB1) (T10A)	Replace fuse PN 12.0008.4.664
After the machine is in the home position, the bedplate shakes in one place. It is not possible to sew next buttonhole.	Incorrect indication of the home position.	Press Emergency Stop button. Manually move the bedplate so it is out of a table sensors. Release Emergency Stop button and press  button to bring the machine to the home position.

Revised 03/2006

e-mail: [service@amfreece.cz](mailto:service@amfreece.cz); [parts@amfreece.cz](mailto:parts@amfreece.cz); website: [www.amfreece.com](http://www.amfreece.com)

Phones: +420 582 309 146 (Service), +420 582 309 286 (Spare Parts); Fax: +420 582 360 606

## TROUBLESHOOTING

---