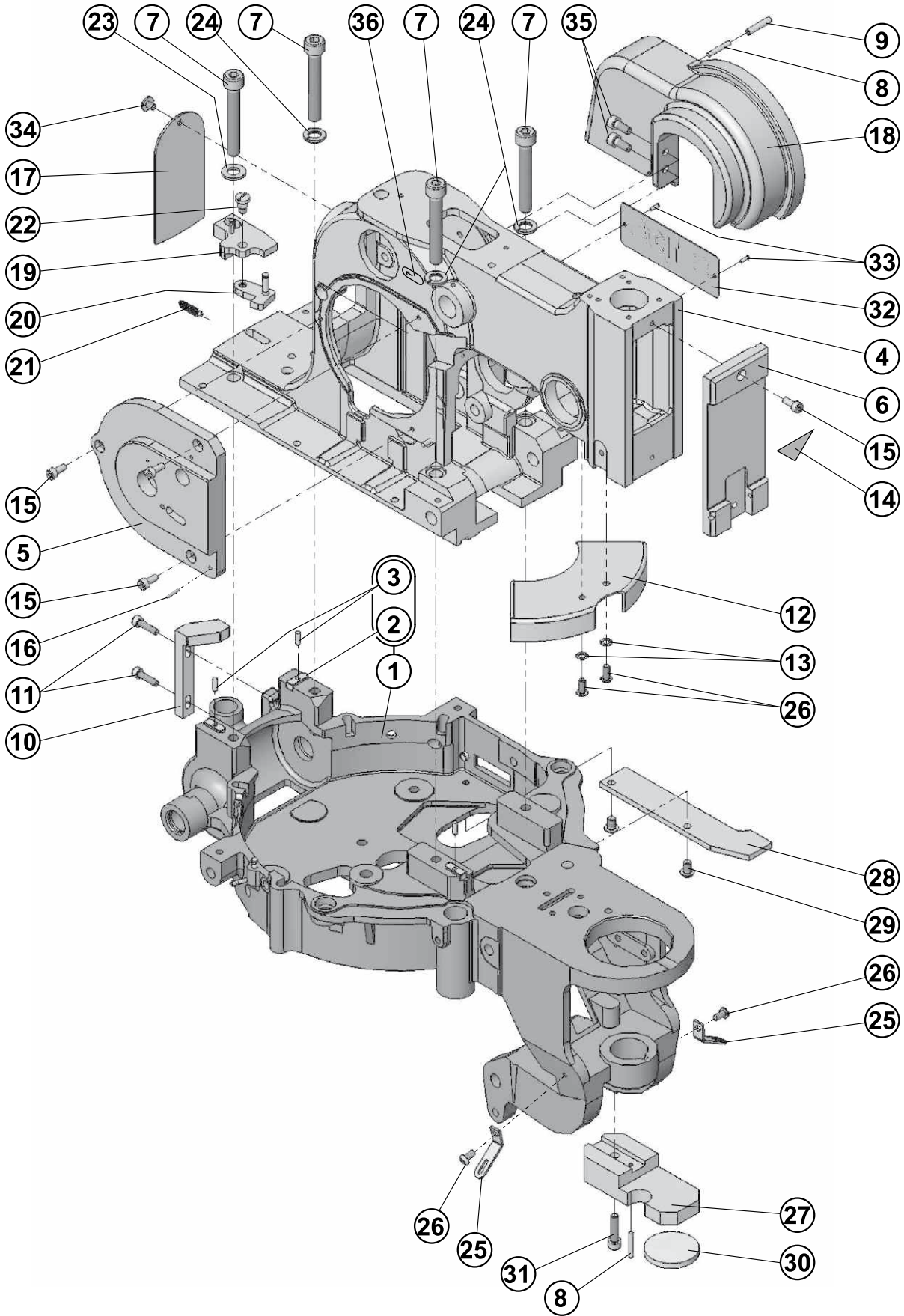

TABLE OF CONTENTS

Head, Cam Case.....	3-2
Stitch Cam Shaft.....	3-4
Needle Bar Drive.....	3-6
Needle Bar.....	3-8
Stitch Bite Drive.....	3-10
Thread Guide and Thread Tension.....	3-12
Thread Take Up Lever.....	3-14
Looper Drive.....	3-16
Lubrication.....	3-18
Race.....	3-20
Main Cam Drive Shaft.....	3-24
Main Cam.....	3-26
Feeding and Density Mechanism.....	3-28
Treble-Arm Lever and Sewing Switch-Off.....	3-30
Rocking Lever.....	3-32
Upper Thread Trimmer and Thread Guide.....	3-34
Buttonhole Shape Change.....	3-36
Turning Assembly.....	3-38
Cutting Lever Assembly.....	3-40
Table Side Movement.....	3-42
Sewing Operation and Fly Bar.....	3-44
Starting Lever.....	3-46
Clamp Yoke and Shifting Lever.....	3-48
Spreading.....	3-50
Clamping Mechanism.....	3-52
Clamp Plate Assembly.....	3-54
Covers.....	3-56
Table.....	3-60
Drive.....	3-62
Accessories.....	3-64

HEAD, CAM CASE



HEAD, CAM CASE

DET	PART NUMBER	DESCRIPTION	QTY.
01	11.3001.0.000	CAM CASE	1
02	11.3001.0.902	KEY	(3)
03	12.1010.0.310	PIN 3-10	(3)
04	11.1001.0.000	HEAD	1
05	11.1188.0.000	COVER ●	1
06	11.1082.0.000	COVER ●	1
07	08.6000.8.055	SCREW M8-55	4
08	12.1010.0.320	PIN 3-20	2
09	19.0094.2.409	JOINT PM	1
10	13.3083.0.000	SUPPORT	1
11	08.6000.4.016	SCREW M4-16	2
12	10.1145.2.000	SHIELD GRAY	1
13	08.6832.4.000	WASHER M4	2
14	05.1389.0.000	LABEL TRIANGLE ●●●	1
15	08.6000.4.010	SCREW M4-10	4
16	12.1010.0.314	PIN 3-14	1
17	10.1080.0.000	REAR COVER GRAY	1
18	11.1195.0.000	HOLDER ●	1
19	10.1180.0.000	BLOCK	1
20	10.1181.0.000	LATCH	1
21	01.5473.0.000	SPRING - EXTENSION	1
22	01.1100.0.000	SCREW	1
23	08.6850.8.000	WASHER 8	1
24	08.6800.8.000	SPRING WASHER M8	3
25	10.3607.1.000	CORD GUIDE	2
26	08.6200.4.008	SCREW M4-8	4
27	11.5008.0.000	ABUTMENT ●	1
28	11.3002.0.000	PLATE	1
29	08.6200.5.008	SCREW M5-8	2
30	19.0094.5.409	FELT ●●●	1
31	08.6000.5.020	SCREW M5-20	1
32	12.8000.1.027	LABEL S105 ●	1
33	12.1016.0.002	NAIL 1,86x6,35	2
34	08.6522.4.006	SCREW M4-6	1
35	08.6000.5.012	SCREW M5-12	2
36	05.0413.0.000	DECAL, OIL	1

STITCH CAM SHAFT

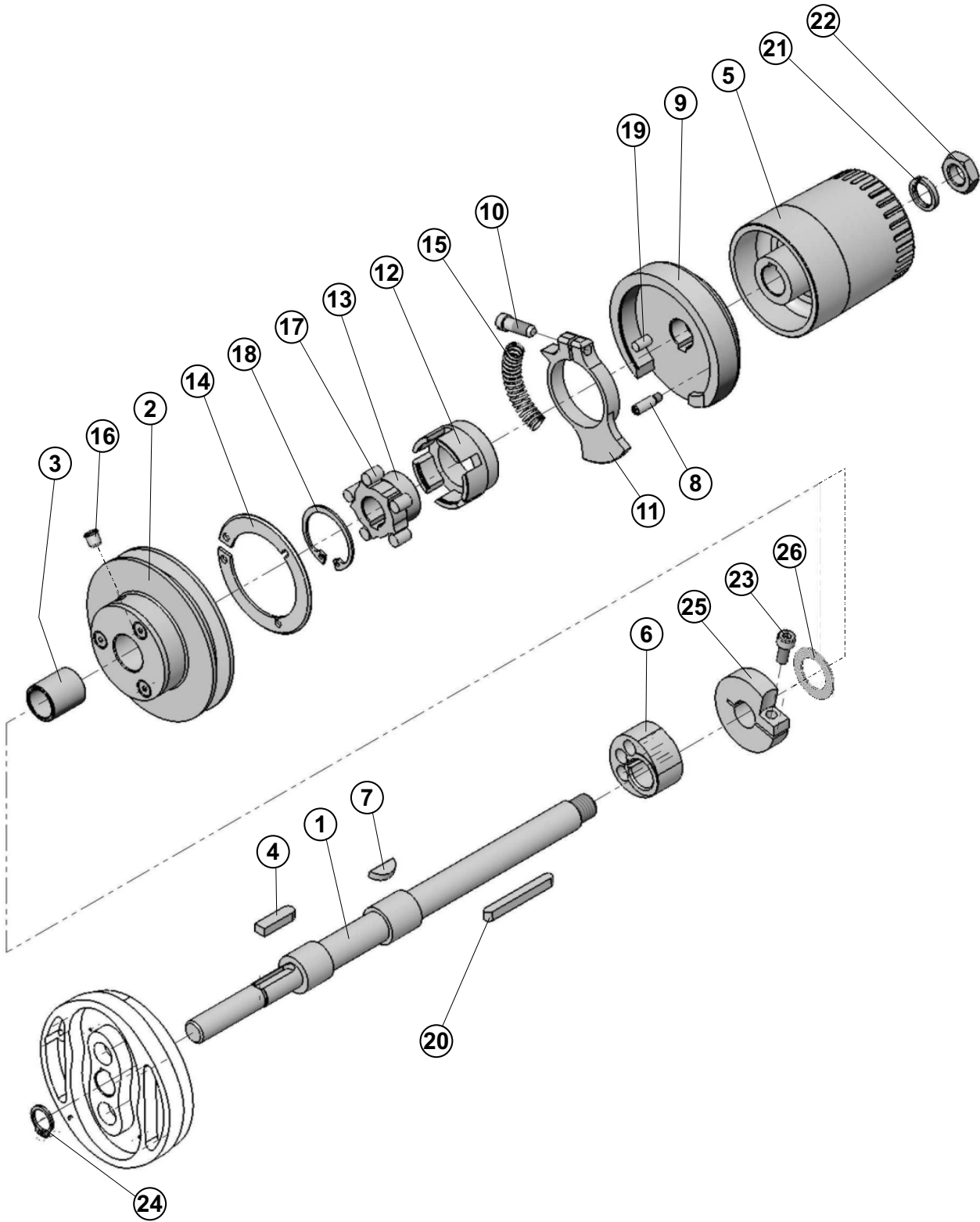

NEEDLE BAR DRIVE

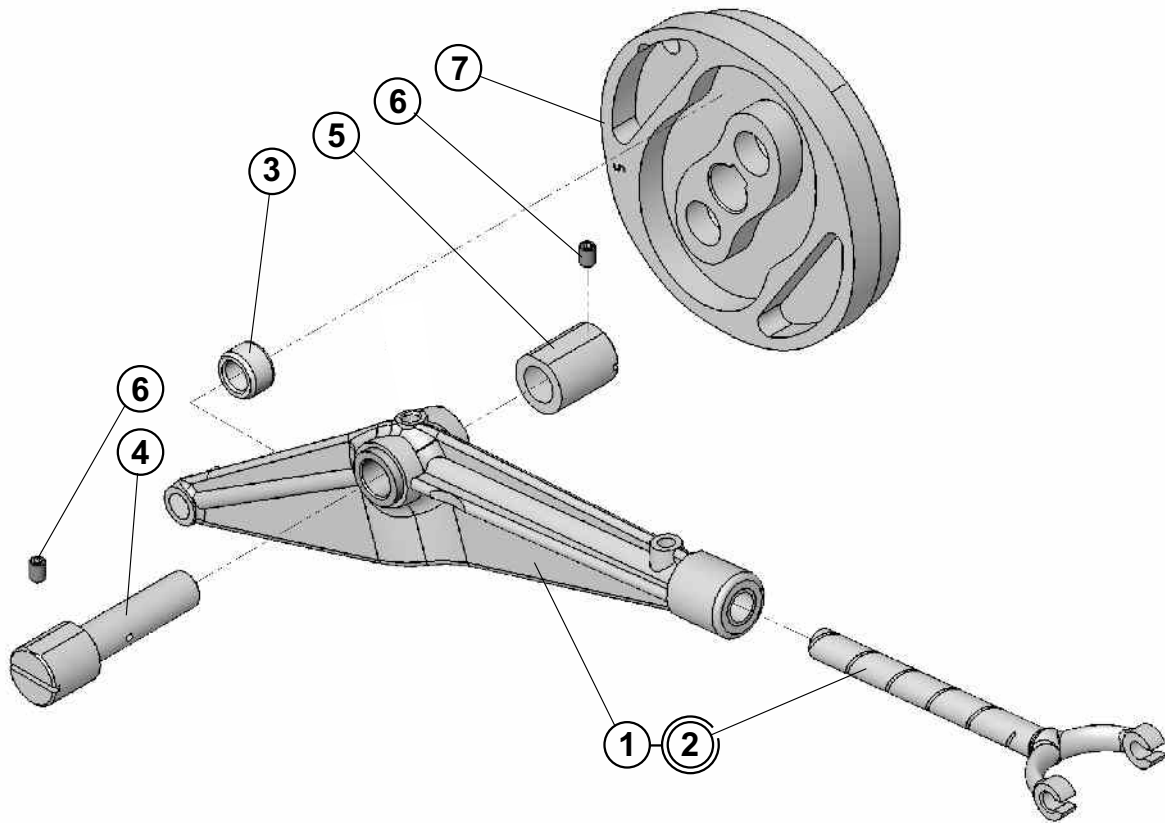

NEEDLE BAR

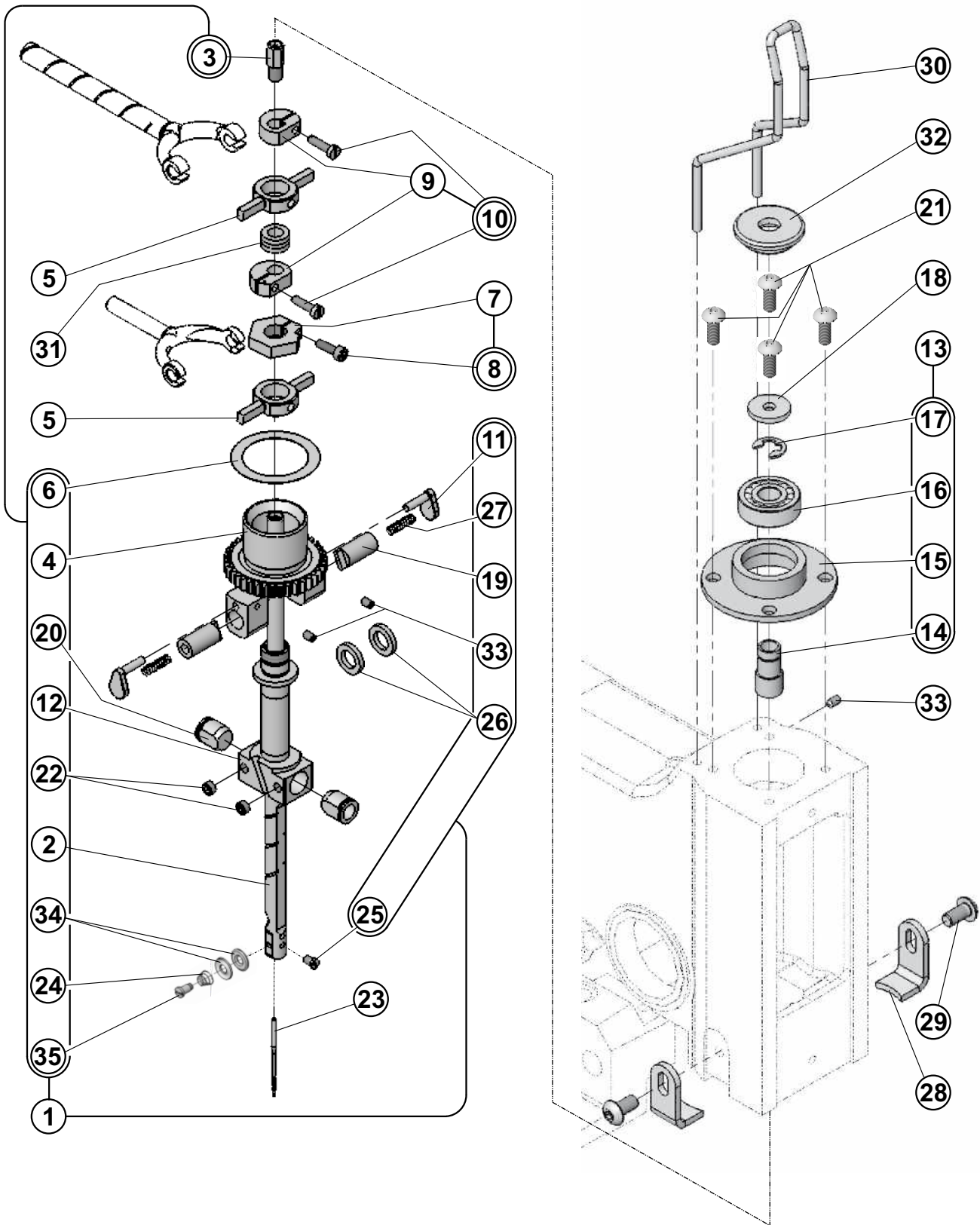

STITCH BITE DRIVE

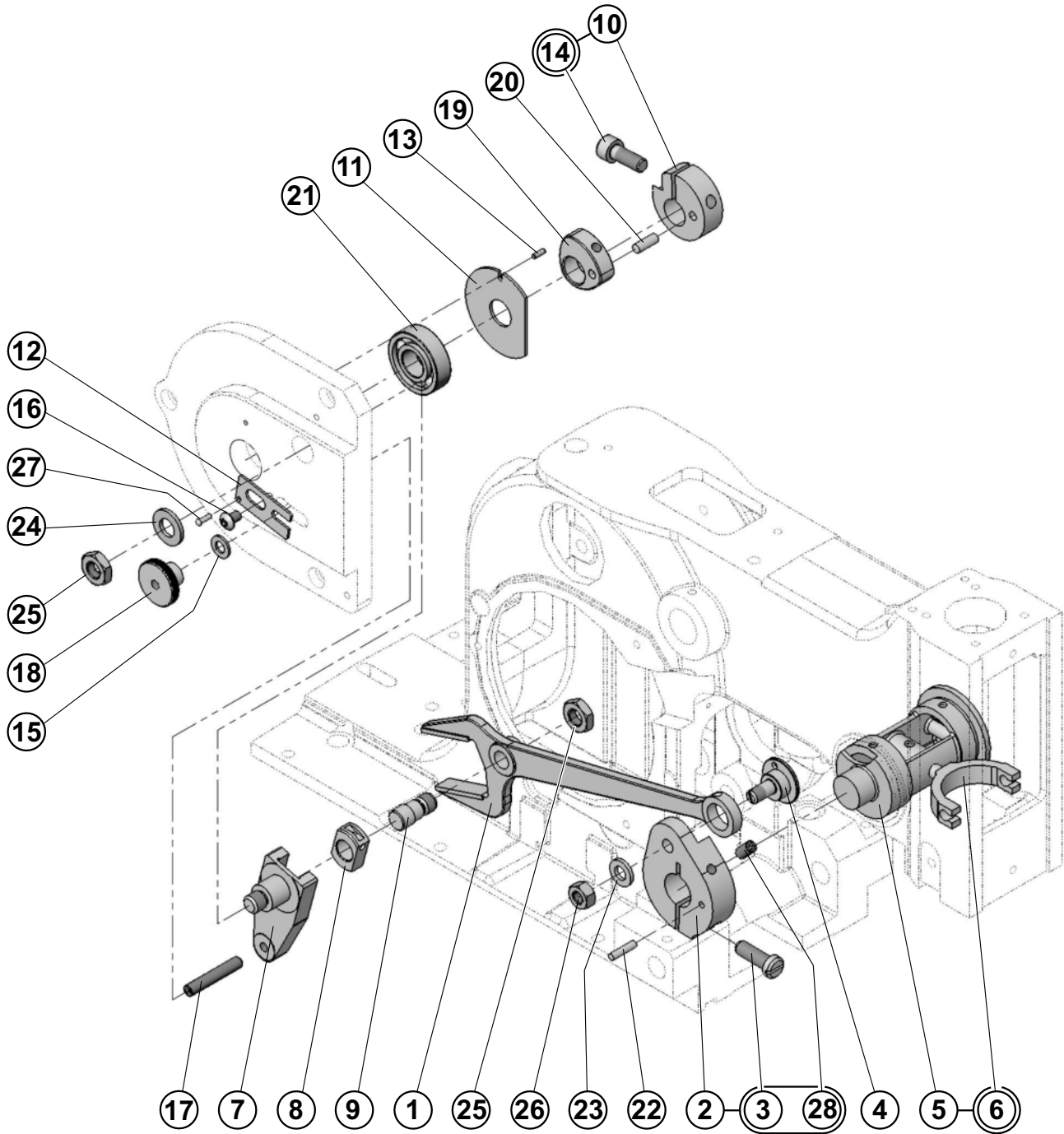

STITCH BITE DRIVE

DET	PART NUMBER	DESCRIPTION	QTY.
01	11.1041.0.000	FORK LEVER	1
02	11.1038.1.000	ROCKING LEVER	1
03	17.0012.1.169	SCREW M6x0,75-18	(1)
04	11.1039.0.000	ECCENTRIC	1
05	11.1035.0.000	VIBRATION BARREL	1
06	19.0063.4.400	FORK	(1)
07	11.1043.0.000	BRACKET	1
08	17.0045.1.099	BLOCK, SLIDE	1
09	17.0033.1.109	SCREW	1
10	15.4405.0.400	COLLAR	1
11	11.1037.0.000	WASHER	1
12	11.1040.0.000	LIMITER	1
13	12.1010.0.206	PIN 2-6	1
14	08.6000.6.016	SCREW M6-16	(1)
15	08.6850.5.000	WASHER 5,3	1
16	08.6200.4.006	SCREW M4-6	1
17	08.6400.5.030	SCREW M5-30	1
18	17.0017.2.049	NUT M5	1
19	19.0067.2.415	CAM	1
20	12.1010.0.412	PIN 4n6x12	1
21	12.2010.0.011	BEARING 6001 2Z	1
22	12.1010.0.314	PIN 3x14	1
23	08.6850.6.000	WASHER 6,4	1
24	17.0019.0.662	WASHER 8,4	1
25	17.0016.1.191	NUT M8x1 LOW	2
26	17.0016.1.118	NUT M6x0,75	1
27	12.1016.0.002	NAIL 1,86x6,35	1
28	08.6400.5.010	SCREW M5-10	(1)

THREAD GUIDE AND THREAD TENSION

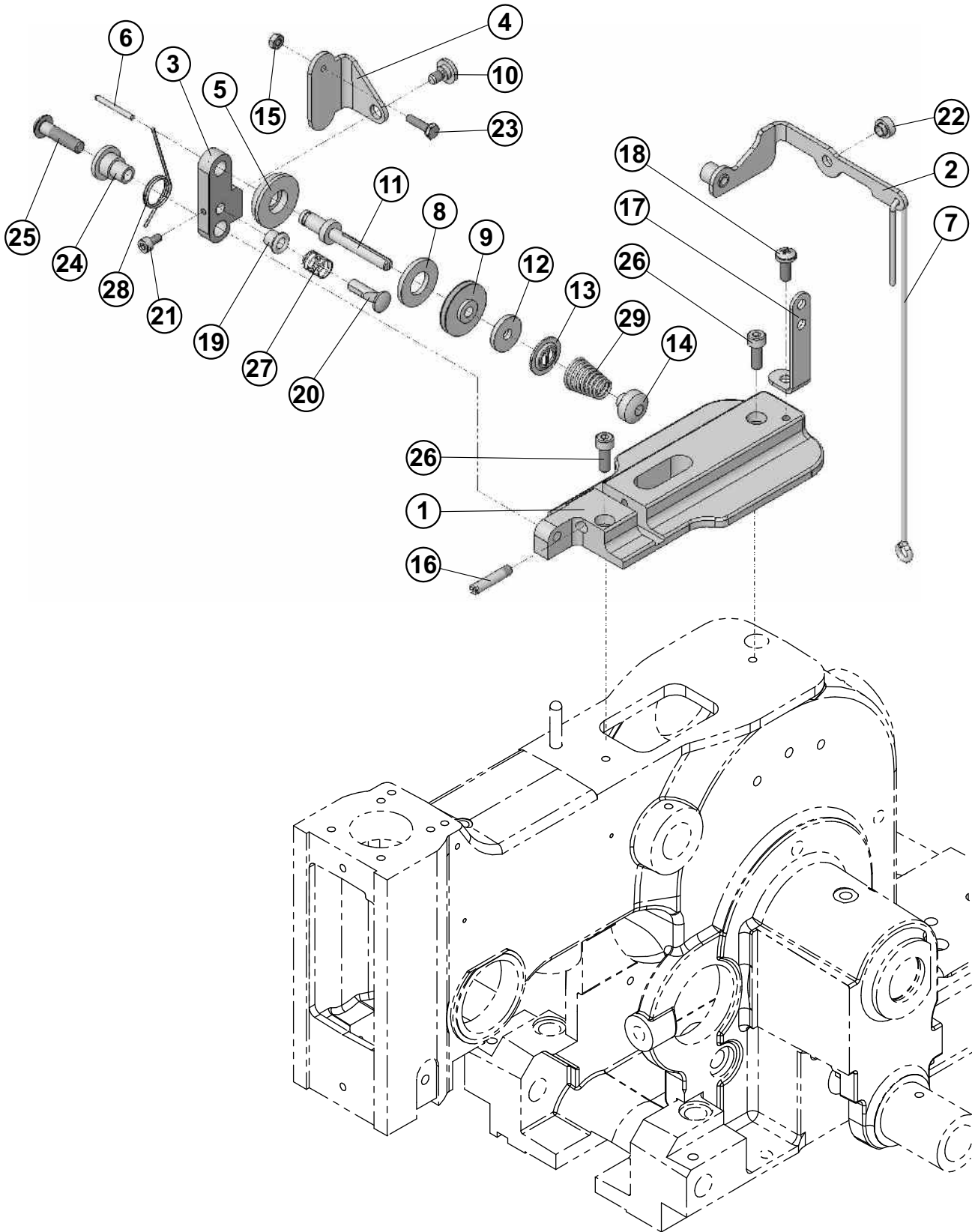

THREAD GUIDE AND THREAD TENSION

DET	PART NUMBER	DESCRIPTION	QTY.
01	11.1159.0.000	BRACKET TENSION	1
02	11.1177.0.000	LEVER	1
03	11.1158.0.000	LEVER	1
04	11.1178.0.000	RELEASE LEVER	1
05	01.4074.0.000	WASHER - ROUNDED	1
06	10.1010.0.000	ROD	1
07	10.1083.0.000	LINK - TENSION RELEASE	1
08	10.1077.0.000	WASHER - FELT	1
09	10.1078.1.000	TENSION ROLLER - ASSEMBLY	1
10	17.0013.1.177	STUD	1
11	01.1113.0.000	STUD	1
12	10.1004.0.000	WASHER - THIN FELD	1
13	10.1003.0.000	WASHER	1
14	10.4030.0.000	NUT - KNURLED	1
15	08.6700.3.000	NUT M3	1
16	19.0011.1.402	BITE SCREW	1
17	05.0043.1.000	THREAD GUIDE	1
18	08.6032.4.010	SCREW M4-10	1
19	10.1009.0.000	BUSHING	1
20	10.1008.0.000	GUIDE	1
21	08.6000.3.006	SCREW M3-6	1
22	11.1175.0.000	BUSHING	1
23	08.6310.3.012	SCREW M3-12	1
24	11.1044.0.000	BUSHING	1
25	08.6200.5.020	SCREW M5-20	1
26	08.6000.4.016	SCREW M4-16	2
27	01.5002.0.000	SPRING - COMPRESSION	1
28	01.5163.0.000	SPRING - TORSION	1
29	01.5603.0.000	SPRING - CONCAL	1

THREAD TAKE UP LEVER

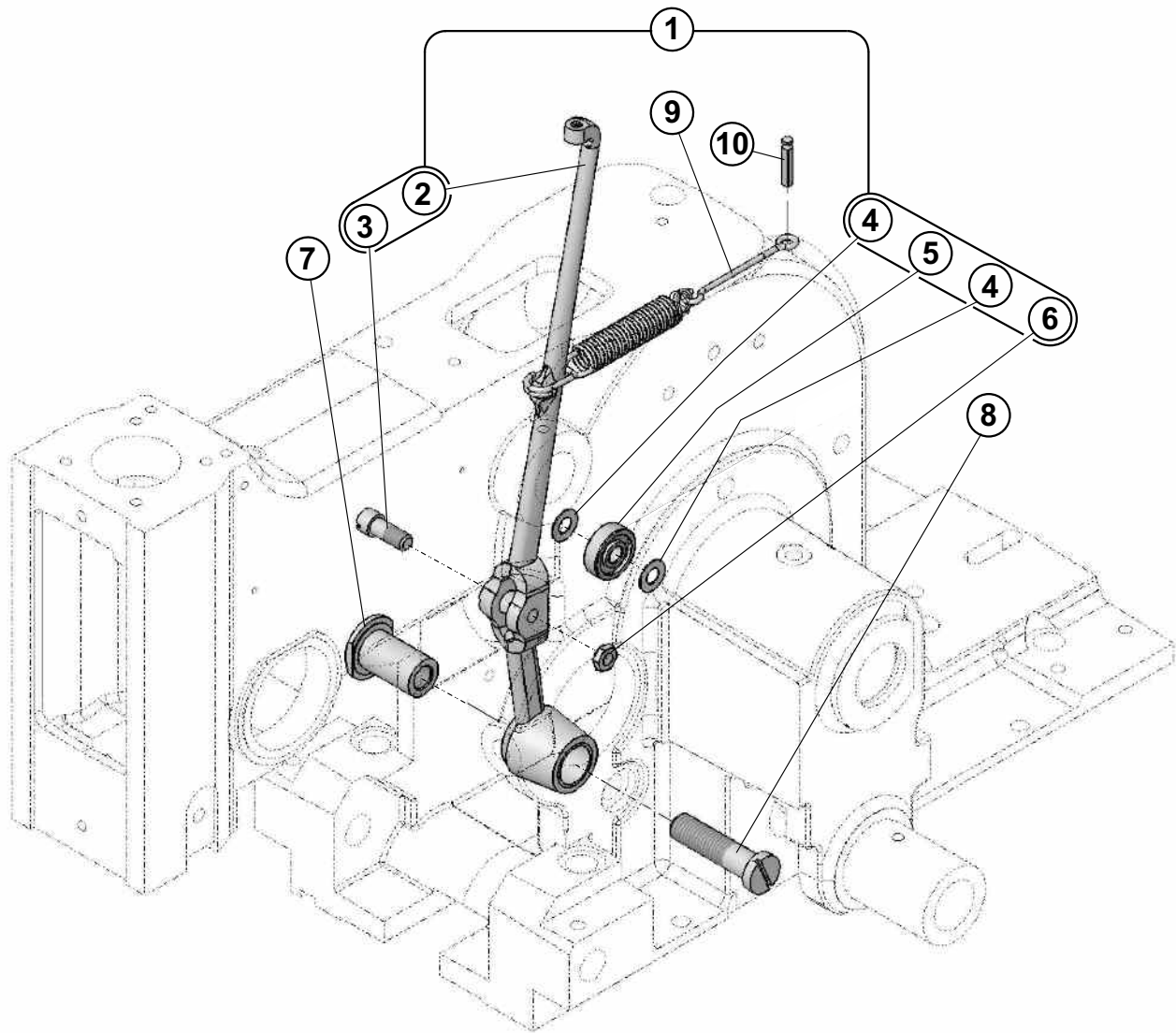

LOOPER DRIVE

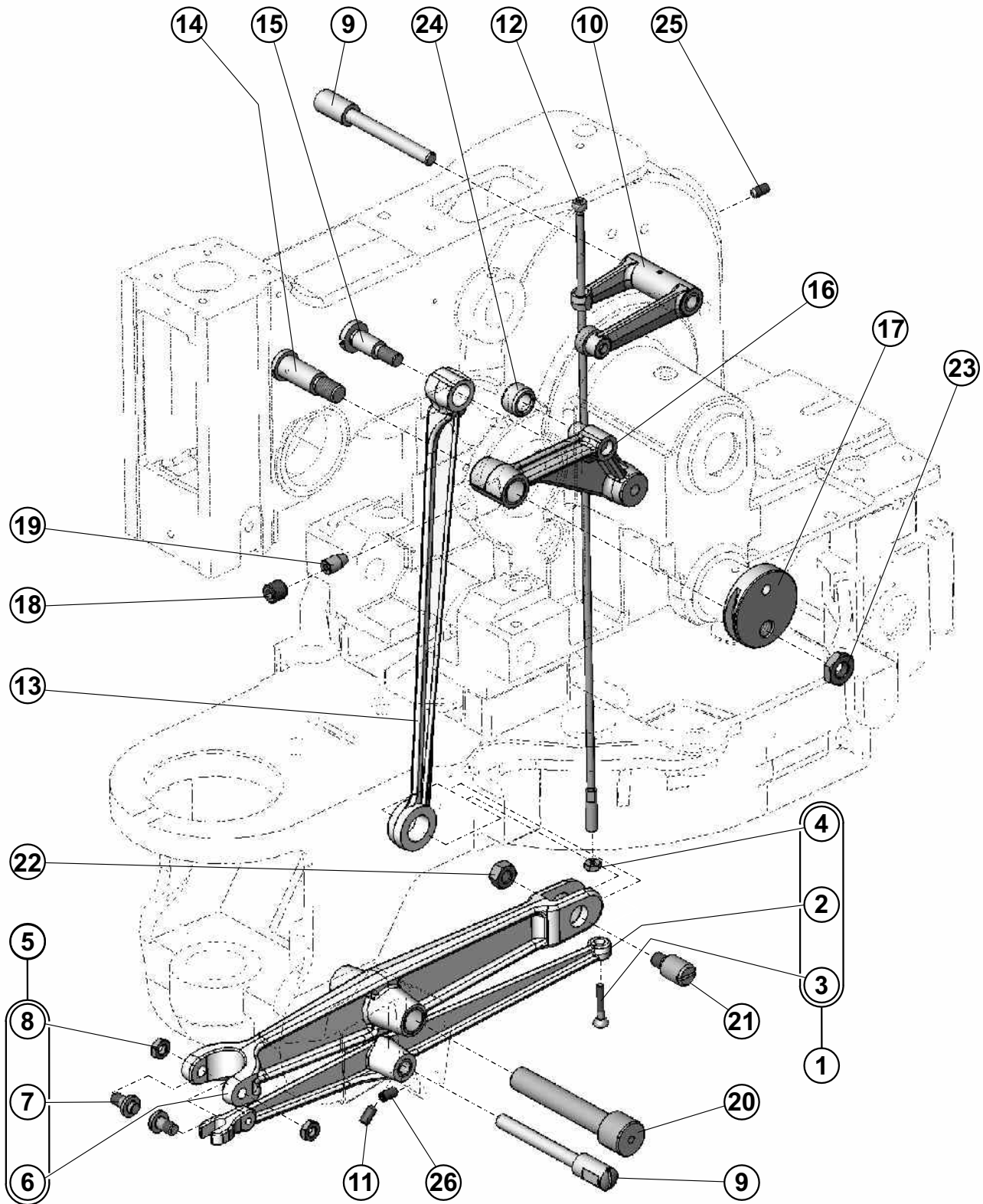

LOOPER DRIVE

DET	PART NUMBER	DESCRIPTION	QTY.
01	11.3004.0.050	SPREADER ROCKER - ASSEMBLY	1
02	11.3004.0.000	SPREADER ROCKER ●	(1)
03	11.1061.0.000	SCREW BALL	(1)
04	08.6700.3.000	NUT M3	(1)
05	11.3006.0.050	LOOPER ROCKER - ASSEMBLY	1
06	11.3006.0.000	LOOPER ROCKER ●	(1)
07	17.0033.3.131	PLUG	(2)
08	08.6710.5.000	NUT M5	(2)
09	11.1059.0.000	PLUG	2
10	11.1058.0.050	SPREADER CAM FOLLOWER ●	1
11	08.6400.4.008	SCREW M4-8	1
12	11.1060.0.050	ROD - ASSEMBLY	1
13	11.1067.0.000	LINK LOOPER ●	1
14	11.1063.0.000	SCREW	1
15	11.1066.0.000	SCREW - SHOULDER	1
16	11.1064.0.000	CAM FOLLOWER ●	1
17	11.1026.0.000	CORE DISC	1
18	08.6400.8.008	SCREW M8-8	1
19	10.1062.0.000	JAM PLUG ●●	1
20	19.0032.6.401	PLUG	1
21	17.0033.1.011	PLUG	1
22	08.6700.6.300	NUT M6x0,75	1
23	08.6710.8.400	NUT M8x1	1
24	11.1122.0.980	ROLL 15	1
25	08.6400.5.008	SCREW M5x8	1
26	08.6400.4.006	SCREW M4-6	1

LUBRICATION

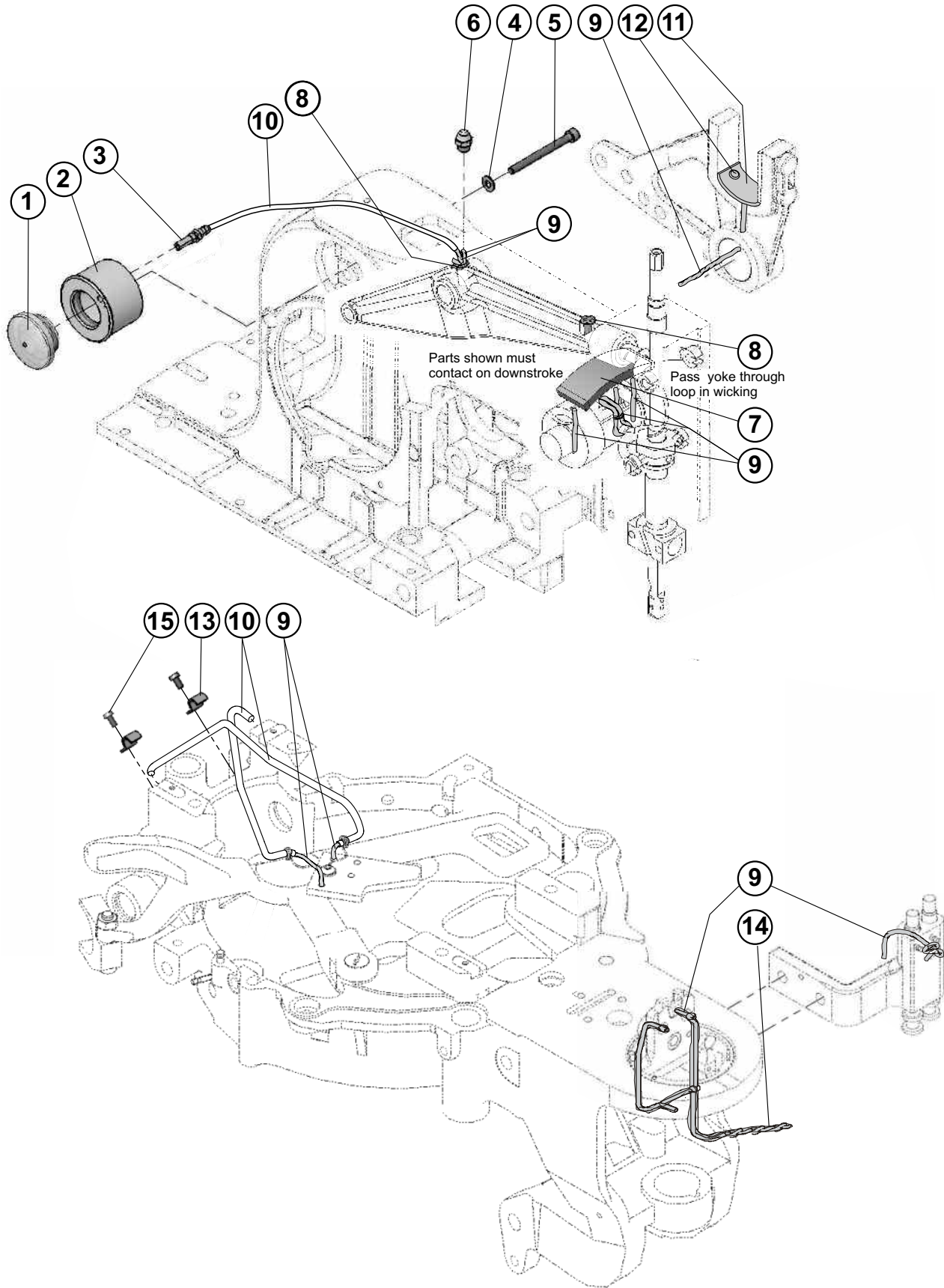

LUBRICATION

DET	PART NUMBER	DESCRIPTION	QTY.
01	17.0095.1.329	OIL INDICATOR ●●●	1
02	22.0104.0.000	OIL GAUGE RESERVOIR	1
03	22.0229.0.000	STRAIGHT FITTING	1
04	08.6850.4.000	WASHER M4	1
05	08.6000.4.045	SCREW M4-45	1
06	17.0004.7.242	PLUG M6	1
07	14.1015.0.000	PAD OIL - VIBRATOR BARREL ●●●	1
08	05.1105.0.000	INLET-OIL ●●	2
09	11.1030.0.000	WICK ●●●	1
10	11.1031.0.000	OIL TUBE ●●●	1
11	14.1029.0.000	OIL PAD ●●●	1
12	12.4021.0.312	RIVET 3x12 AL ●	1
13	17.0082.6.000	CLAMP	2
14	07.0401.0.009	WICKING ●●●	1
15	08.6010.3.006	SCREW M3-6 ISO 1207	2

RACE

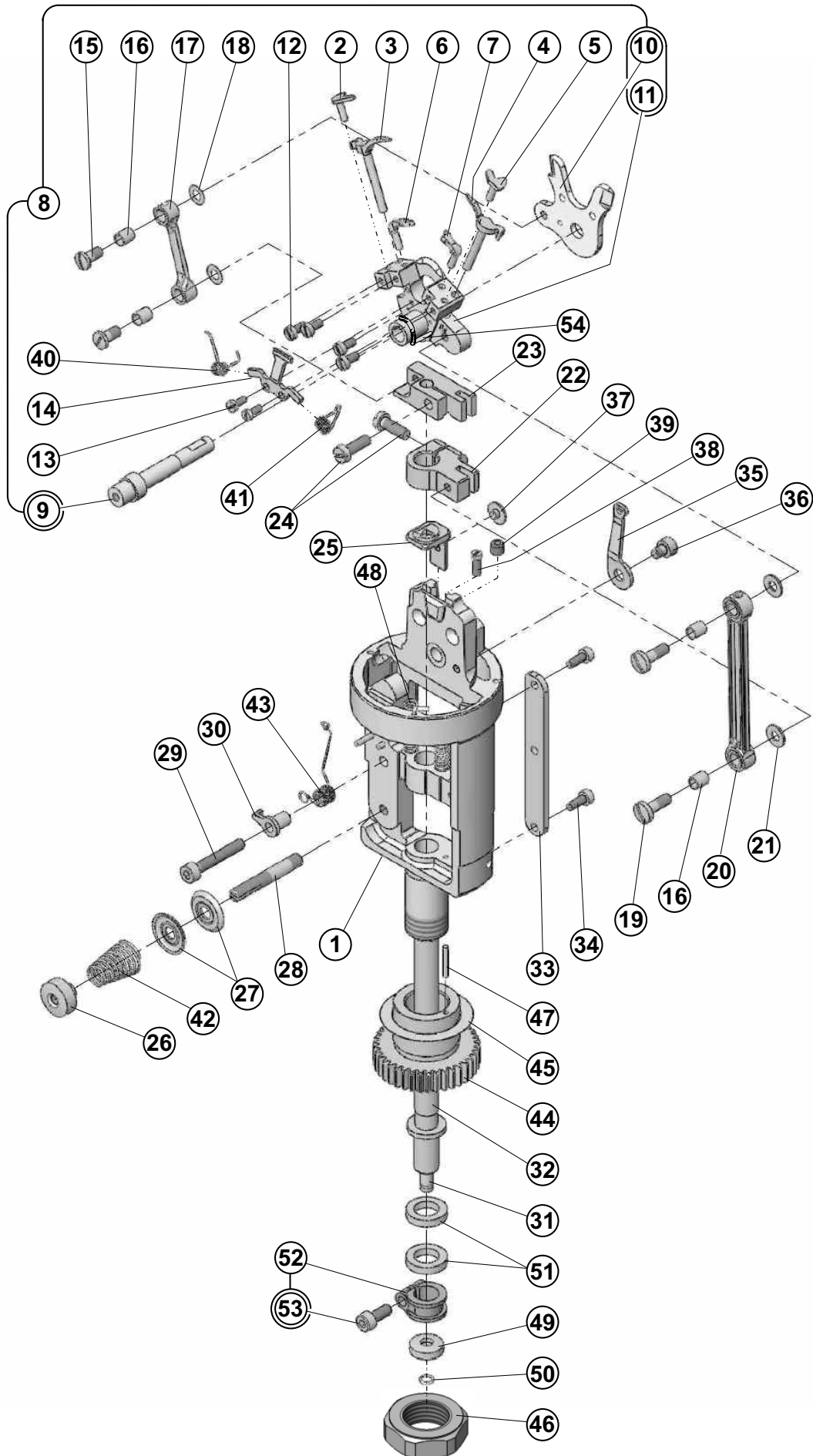

RACE

DET	PART NUMBER	DESCRIPTION	QTY.
01	11.4001.0.050	RACE - ASSEMBLY	1
02	11.4007.0.000	SPREADER STOP LH	1
03	11.4009.0.000	SPREADER LH	1
04	11.4008.0.000	SPREADER RH	1
05	11.4006.0.000	SPREADER STOP RH	1
06	11.4005.0.000	EYE LOOPER	1
07	11.4004.0.000	BLIND LOOPER	1
08	11.4002.0.050	CUPPER CARRIER - ASSEMBLY	1
09	11.4201.0.000	STUD LOOPER CARRIER	(1)
10	11.4011.0.000	SPREADER WEDGE - CB	(1)
11	11.4002.0.000	CARRIER - LOOPER	• (1)
12	08.6010.3.006	SCREW M3-6	4
13	17.0012.0.404	SCREW	2
14	10.4010.2.000	NEEDLE GUARD	1
15	17.0012.1.140	SCREW	2
16	17.0041.1.094	BUSHING	4
17	19.0063.1.073	SPREADER LINK	1
18	17.0019.0.228	WASHER	2
19	17.0012.1.142	SCREW	2
20	17.0004.4.829	LOOPER LINK	2
21	17.0019.1.088	WASHER	2
22	17.0074.4.405	CLAMP	• 1
23	17.0064.6.117	CLAMP	• 1
24	08.6010.4.012	SCREW M4-12	2
25	10.4012.2.004	THROAT PLATE	1
26	17.0017.1.016	NUT	1
27	17.0082.8.084	TENSION PLATE	2
28	17.0011.8.041	SCREW	1
29	08.6000.4.025	SCREW M4-25	1
30	17.0064.7.162	PLATE	1
31	11.4020.0.000	SPREADER SPINDLE	1
32	19.0034.6.402	SHAFT, LOOPER DRIVE	• 2
33	17.0081.5.082	WIRE	1
34	08.6000.3.008	SCREW M3-8	2
35	10.4035.0.000	CORD GUIDE	1
36	08.6000.4.005	SCREW M4-5	1
37	01.2056.1.000	SCREW - FULL THREADER	1
38	17.0012.2.400	SCREW	1
39	08.6400.5.005	SCREW M5-5	1
40	15.4531.0.200	SPRING LH	1
41	15.4530.0.200	SPRING RH	1
42	17.0026.2.078	SPRING	1
43	17.0026.4.035	SPRING	1
44	17.0055.1.158	GEAR	1
45	01.4081.0.005	WASHER - PLAIN (0.005")	1
46	17.0016.1.093	NUT	1
47	17.0031.0.406	PIN	1
48	01.5026.0.000	SPRING - COMPRESION	2
49	19.0041.2.404	ROLL	1
50	17.0027.4.045	RING	1



RACE

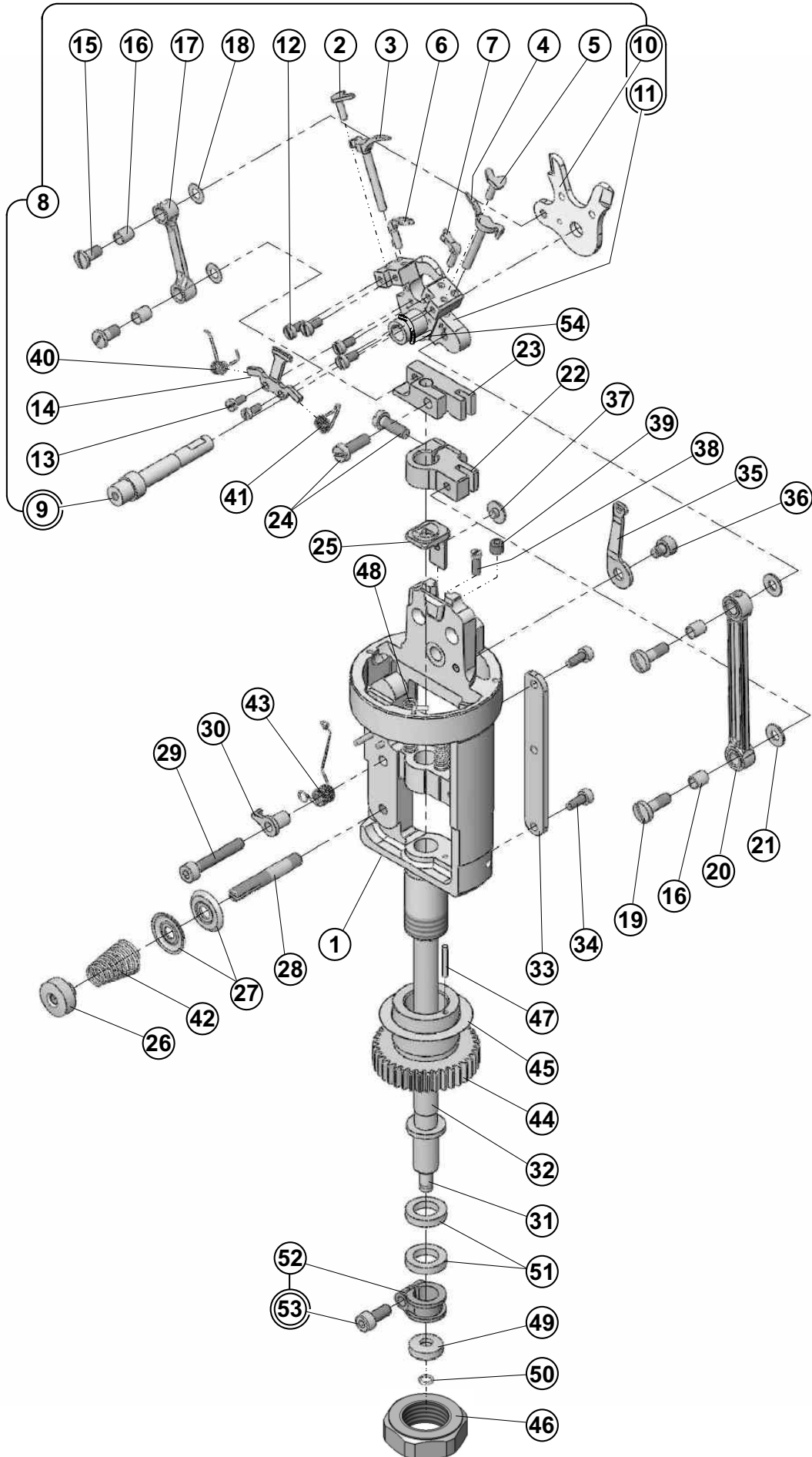

RACE



DET	PART NUMBER	DESCRIPTION	QTY.
51	17.0019.0.398	RING	2
52	19.0043.6.441	CLAMP	1
53	08.6000.4.010	SCREW M4-10	(1)
54	07.0401.0.000	LOOPER CAR	1

--	--	--	--

MAIN CAM DRIVE SHAFT

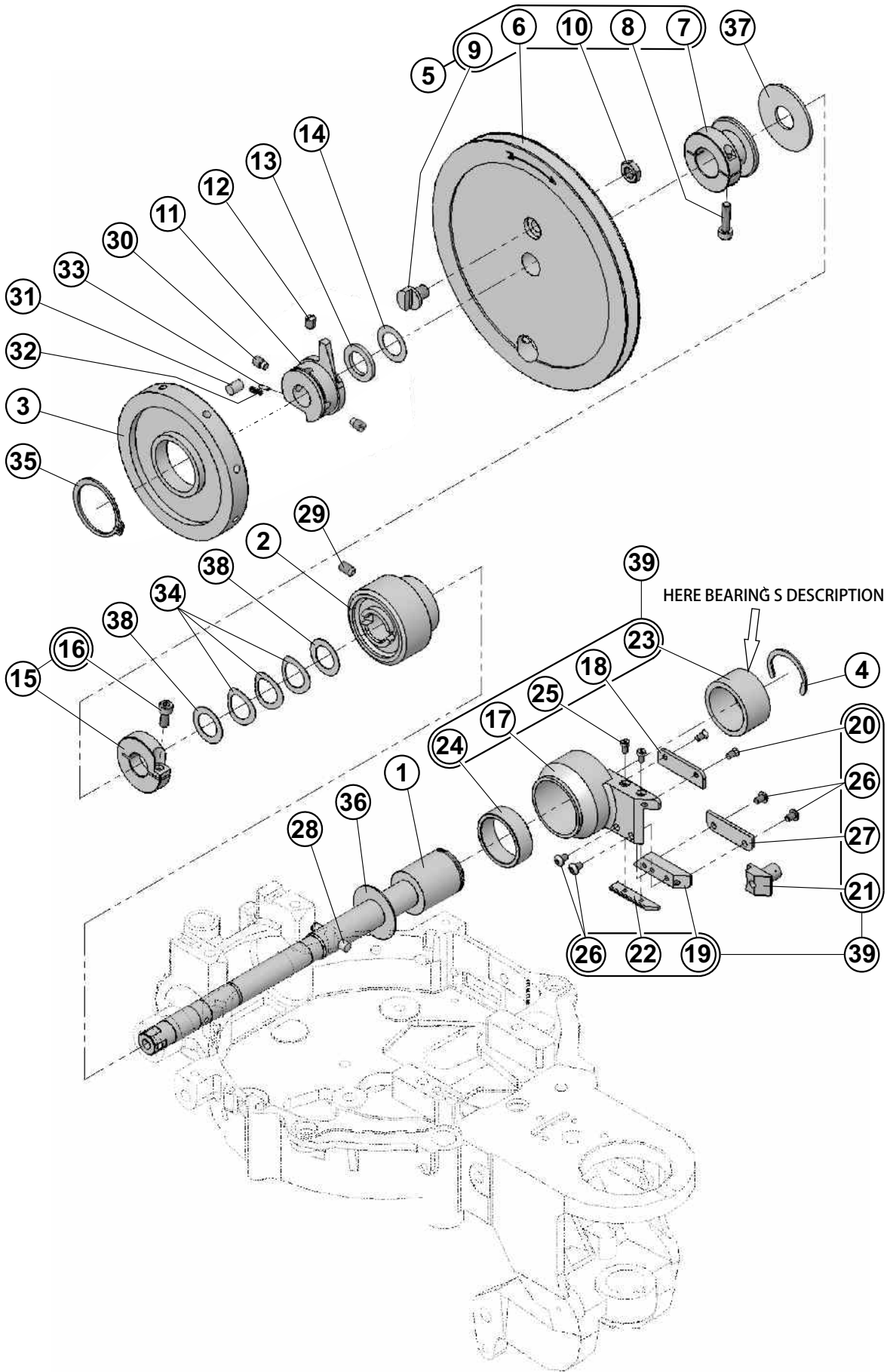

MAIN CAM DRIVE SHAFT

DET	PART NUMBER	DESCRIPTION	QTY.
01	11.3047.0.000	SHAFT	1
02	11.3050.0.000	GEAR	1
03	11.3110.0.000	HAND WHEEL	1
04	01.6970.0.000	RETAING RING	1
05	17.0004.5.386	PULLEY - ASSEMBLY	1
06	17.0052.0.315	PULLEY	(1)
07	17.0044.5114	SPOOL	(1)
08	08.6000.5.020	SCREW M5-20	(1)
09	17.0033.5.113	DOG	(1)
10	08.6710.8.400	NUT M8x1	(1)
11	11.3123.0.000	DRIVE HUB	1
12	17.0011.2.014	SCREW M6x0,75-8	1
13	17.0094.1.143	BUSHING RUBBER	1
14	17.0019.0.610	WASHER	1
15	11.3046.0.000	FRICITION COLLAR	1
16	08.6000.5.016	SCREW M5-16	(1)
17	14.3100.0.901	ARM - FEED CLUTCH	(1)
18	10.3080.0.000	OUTER PLATE	(1)
19	11.3101.0.000	WEAR PLATE	(1)
20	01.2075.0.000	SCREW	(2)
21	11.3079.0.000	SLIDE STUD	(1)
22	11.3082.0.000	PLATE, INNER	(1)
23	12.2090.0.003	BUSHING	(1)
24	01.7040.0.000	COLLAR	(1)
25	08.6010.3.006	SCREW M3-6	(2)
26	08.6200.4.006	SCREW M4-6	(4)
27	11.3080.0.000	OUTER PLATE	(1)
28	12.1010.0.630	PIN 6-30	1
29	08.6400.6.010	SCREW M6-10	1
30	17.0011.2.063	SCREW M6x0,75 - 10	2
31	12.2099.1.006	BEARING ROLLER	1
32	17.0026.0.213	SPRING	1
33	12.1010.0.212	PIN	1
34	01.5683.0.000	DISC SPRING 5/8	3
35	12.1045.1.010	LOCK RING 35	1
36	11.3054.0.000	WASHER	1
37	17.0094.3.142	WASHER FELT	1
38	01.4007.0.000	SHIM RING	2
39	11.3100.0.050	FEED CLUTCH - ASSEMBLY	1

MAIN CAM

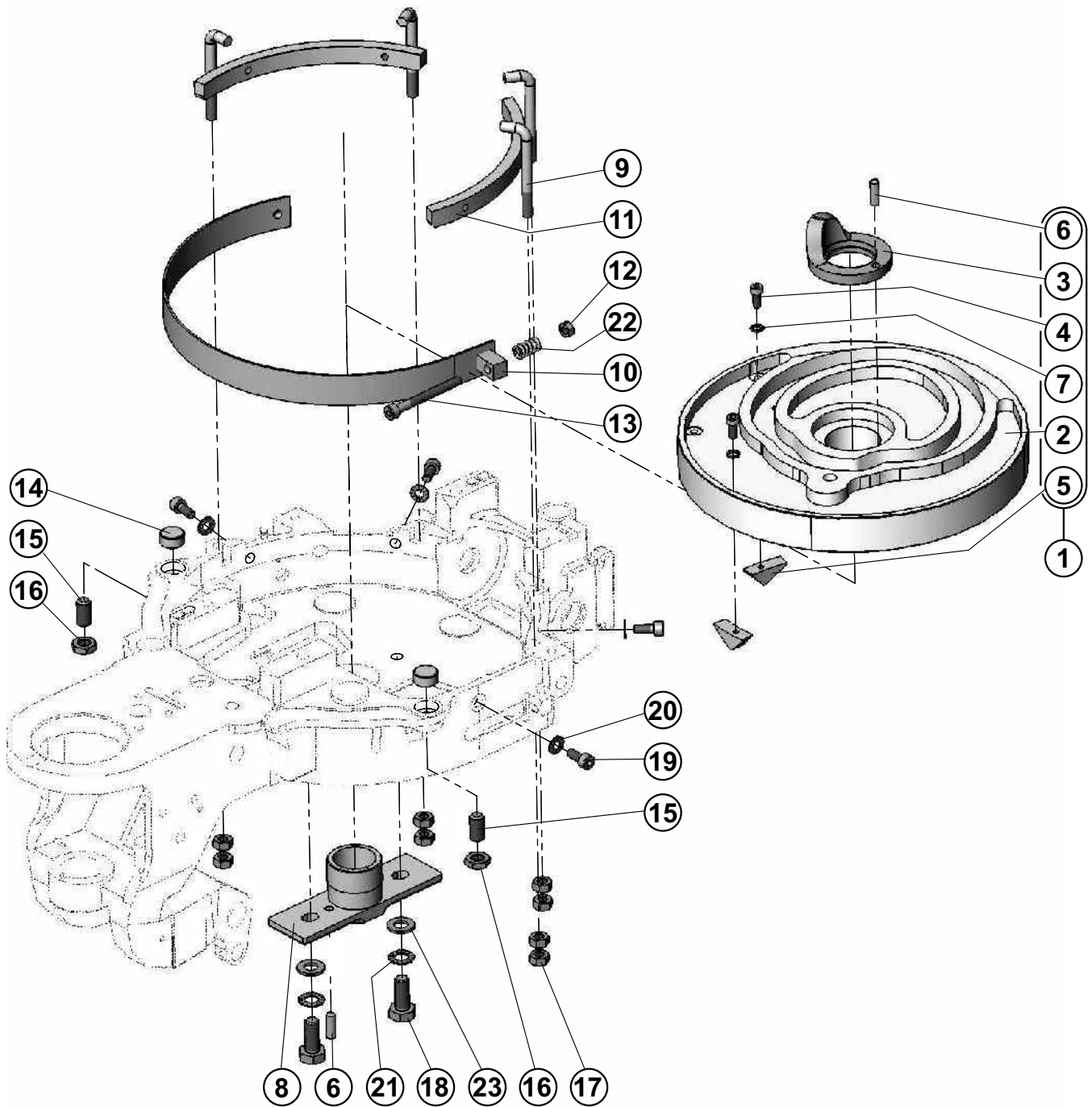

MAIN CAM

DET	PART NUMBER	DESCRIPTION	QTY.
01	11.3064.0.050	MAIN CAM - ASSEMBLY FOR EYE 2,8X4,2	1
01	11.3065.0.050	MAIN CAM - ASSEMBLY FOR EYE 3,4X4,2	1
02	11.3064.0.000	MAIN CAM	(1)
02	11.3065.0.000	MAIN CAM	(1)
03	11.3062.0.000	CUTTING CAM	(1)
04	08.6000.4.010	SCREW M4-10	(2)
05	11.3061.0.000	WEDGE - CLEMPING	(2)
06	12.1010.0.516	PIN 5-16	1+(1)
07	08.6832.4.000	WASHER M4	(2)
08	11.3027.0.000	CAM CENTER	1
09	11.3066.0.000	HOOK	4
10	17.0002.7.589	BRAKE BAND - ASSEMBLY	1
11	11.3035.0.000	GIB HOLD DOWN	2
12	08.6700.5.000	NUT M5	1
13	08.6000.5.050	SCREW M5-50	1
14	17.0019.2.021	STONE	2
15	08.6400.8.416	SCREW M8x1-16	2
16	08.6710.8.400	NUT M8x1	2
17	08.6700.6.300	NUT M6x0,75	8
18	08.6300.8.020	SCREW M8-20	2
19	08.6000.5.012	SCREW M5-12	4
20	08.6850.5.000	WASHER M5	4
21	08.6850.8.000	WASHER M8	2
22	18.0026.0.601	SPRING - COMPRESSION	1
23	08.6832.8.000	WASHER M8	2

FEEDING AND DENSITY MECHANISM

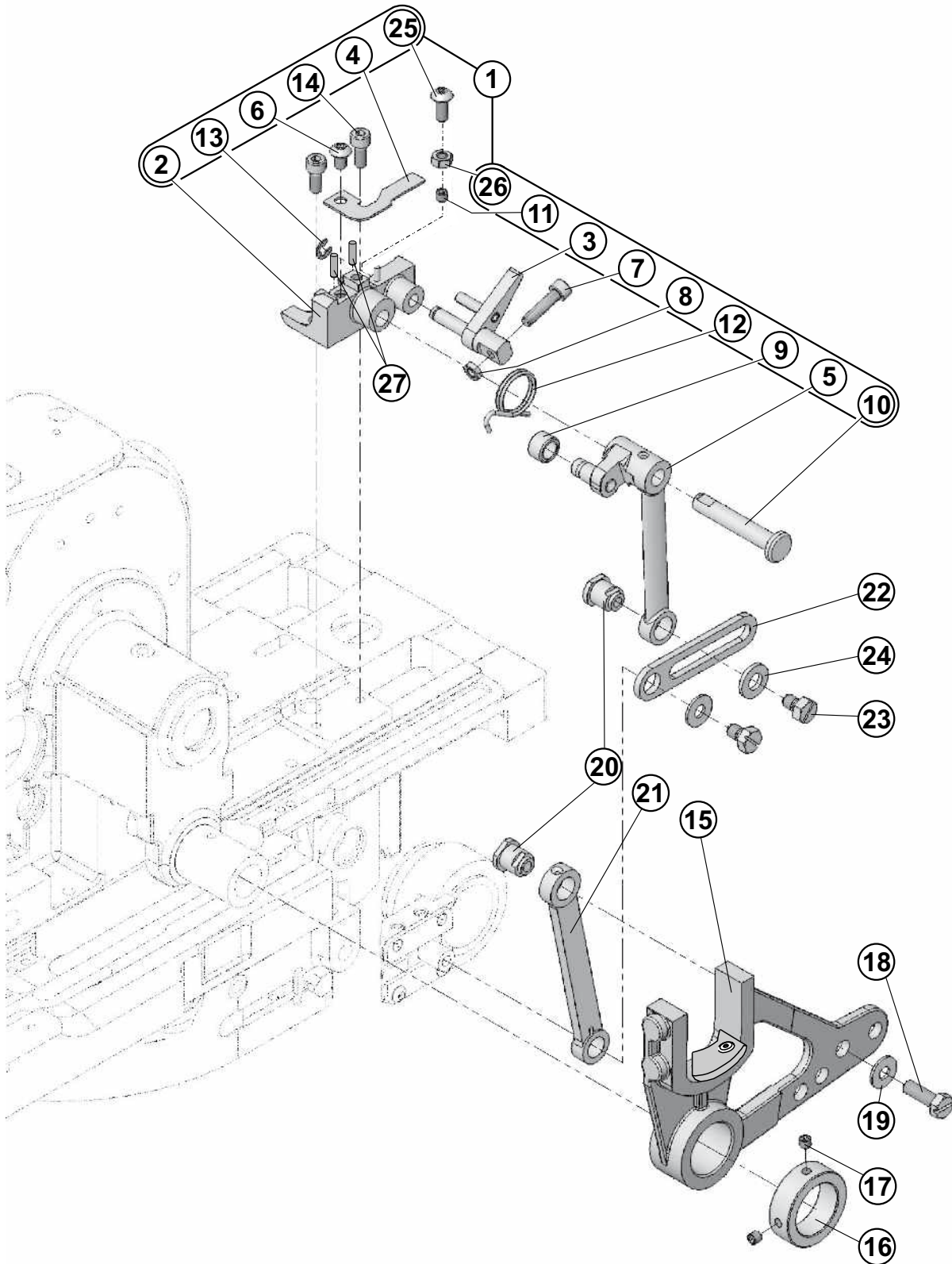

FEEDING AND DENSITY MECHANISM

DET	PART NUMBER	DESCRIPTION	QTY.
01	11.1167.0.050	LINE SHIFTER - ASSEMBLY	1
02	11.1167.0.000	SHIFTER BLOCK	(1)
03	11.1169.0.000	SHIFTER - ASSEMBLY	(1)
04	01.5447.0.000	SPRING - FLAT	(1)
05	11.1168.0.000	LINK	(1)
06	08.6200.5.008	SCREW M5-8	(1)
07	08.6000.5.020	SCREW M5-20	(1)
08	08.6710.5.000	NUT M5	(1)
09	17.0041.8.008	ROLL	(1)
10	11.1184.0.000	STUD	(1)
11	08.6400.5.005	SCREW M5-5	(1)
12	01.5448.0.000	SPRING - TORSION	(1)
13	12.1045.0.004	RETAINING RING 4	(1)
14	08.6000.5.012	SCREW M5-12	(2)
15	11.1108.0.000	FEED CAM FOLLOWER	1
16	11.1111.0.000	COLLAR	1
17	08.6400.5.305	SCREW M5x0,5- 5	2
18	17.0014.1.068	SCREW M6x0,75-23	1
19	17.0019.0.230	WASHER	2
20	11.1171.0.000	STUD	2
21	11.1109.0.000	LINK	1
22	11.3081.0.000	ARM - MASCHINING	1
23	17.0014.1.015	SCREW M6x0,75-9	2
24	11.3083.0.000	WASHER	1
25	08.6200.5.012	SCREW M5-12	(1)
26	08.6700.5.000	NUT M5	(1)
27	12.1010.0.310	PIN 3x10	2

TREBLE-ARM LEVER AND SEWING SWITCH-OFF

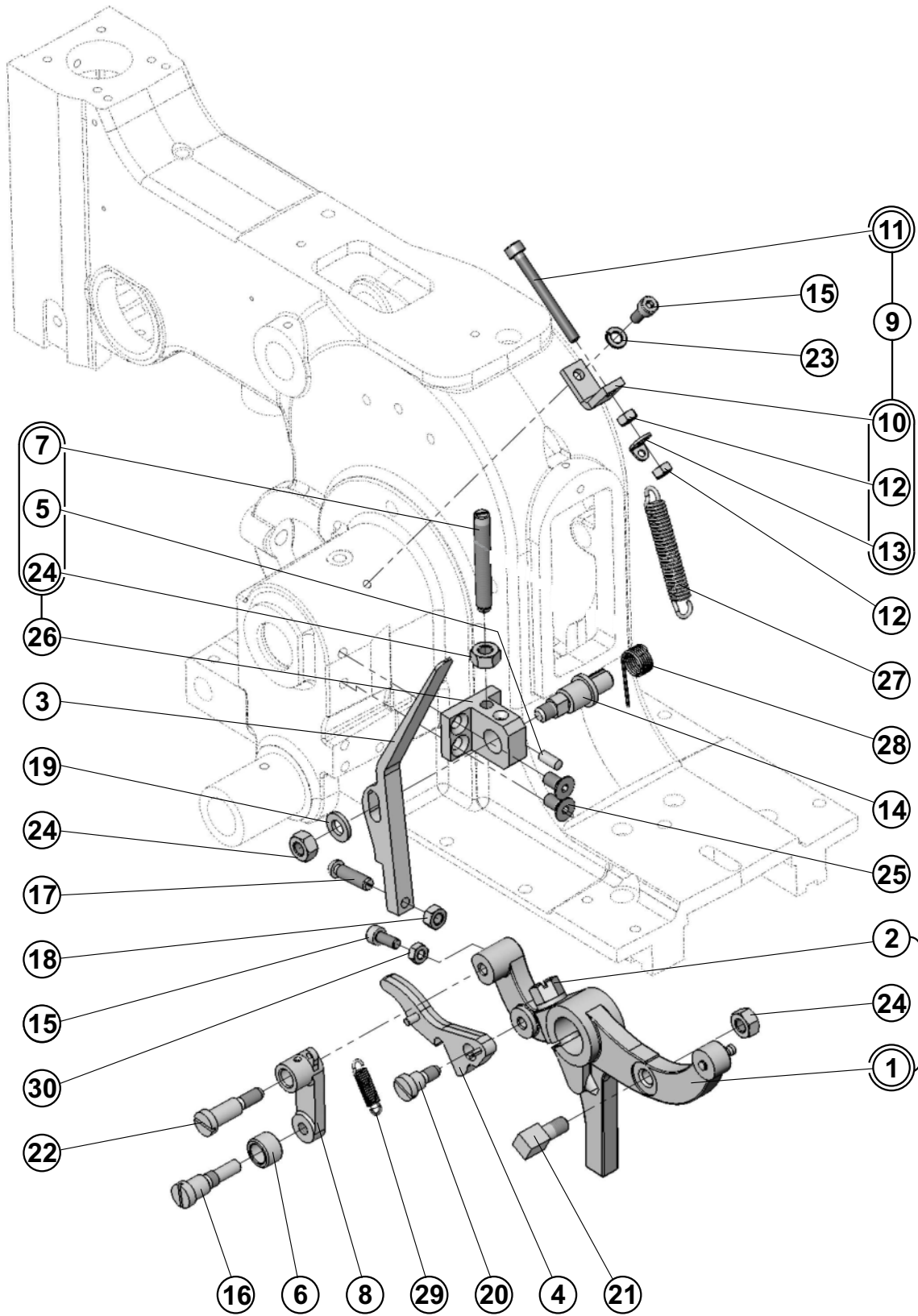

TREBLE-ARM LEVER AND SEWING SWITCH-OFF

DET	PART NUMBER	DESCRIPTION	QTY.
01	11.1113.0.000	THREE FORK LEVER	1
02	17.0014.1.205	SCREW M8x0,75-22.5	(1)
03	11.1124.0.000	TRIP LEVER	1
04	11.1118.0.000	LEVER	1
05	12.1014.0.007	PIN 4-12	(1)
06	17.0041.8.008	ROLL	1
07	17.0011.3.022	SCREW M6-45	(1)
08	11.1120.0.000	LEVER	1
09	01.5055.0.051	LENE SPRINNG BRACKER - ASSEMBLY	1
10	14.1099.0.000	SPRING BRACKET	(1)
11	08.6000.4.040	SCREW M4-40	(1)
12	08.6700.4.000	NUT M4	(2)
13	14.5034.0.000	CORD GUIDE	(1)
14	17.0033.3.053	STUD	1
15	08.6000.4.010	SCREW M4-10	2
16	17.0013.1.419	SCREW M6x0,75-26 E	1
17	17.0012.4.011	SCREW M5-17,5	1
18	08.6700.5.000	NUT M5	1
19	08.6850.6.000	WASHER 6,4	1
20	17.0013.1.417	PLUG	1
21	17.0014.4.001	STUD M6-12	1
22	17.0013.1.418	SCREW M5-27	1
23	08.6800.4.000	WASHER 4	1
24	08.6700.6.000	NUT M6	2+(1)
25	08.6100.5.010	SCREW M5-10	2
26	17.0064.5.174	BRACKET	1
27	01.5055.0.000	SPRING - EXTENSION	1
28	17.0026.4.036	TORSION SPRING	1
29	17.0026.3.126	SPRING	1
30	08.6700.4.000	NUT M4	1

ROCKING LEVER

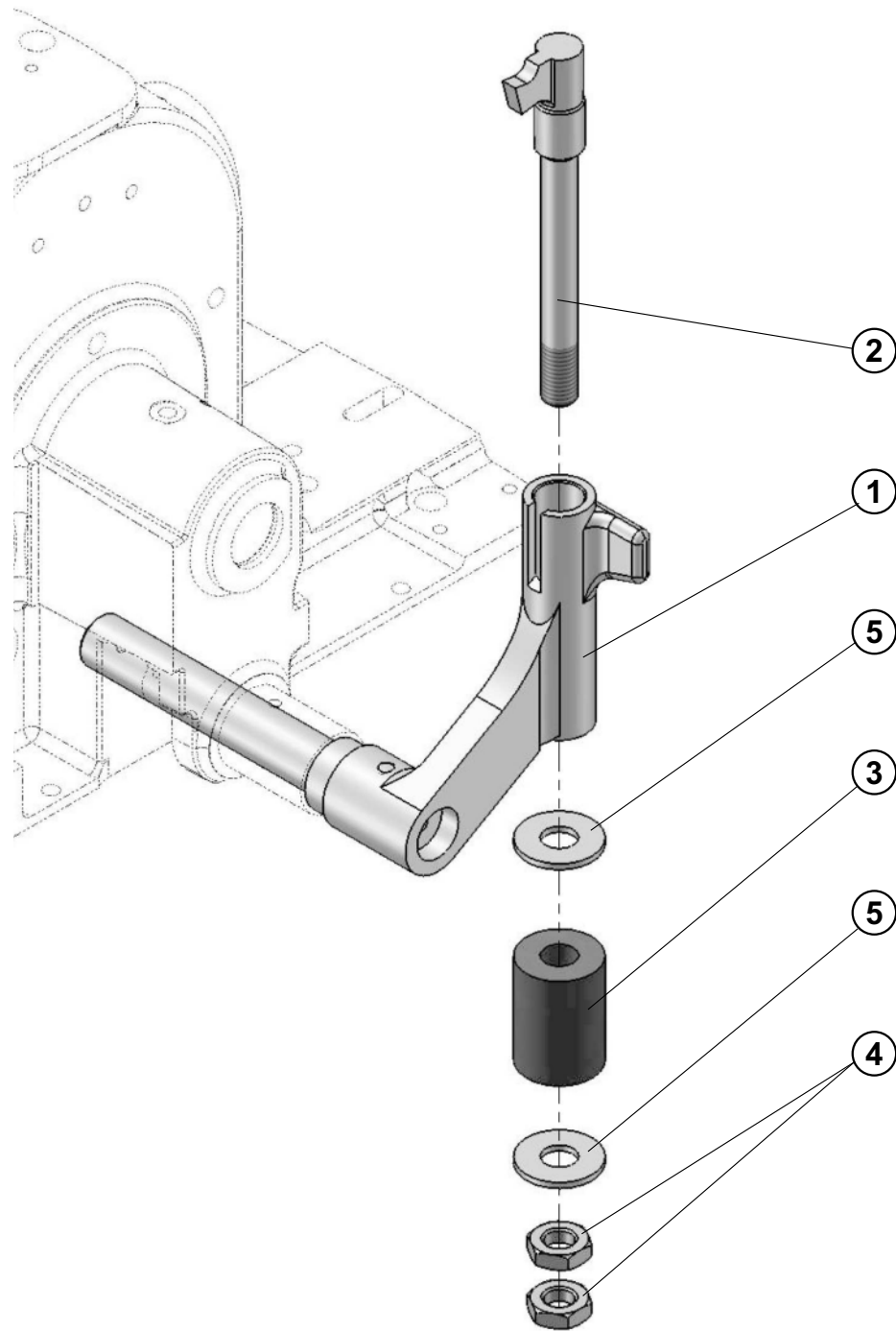

ROCKING LEVER

DET	PART NUMBER	DESCRIPTION	QTY.
01	11.1102.0.000	BREAKE - ASSEMBLY	1
02	17.0062.5.020	BOLT	1
03	11.1101.0.990	SPRING. ELASTOMER ●●●	1
04	08.6717.0.000	NUT M10	2
05	08.6872.0.000	WASHER 10	2

UPPER THREAD TRIMMER AND THREAD GUIDE

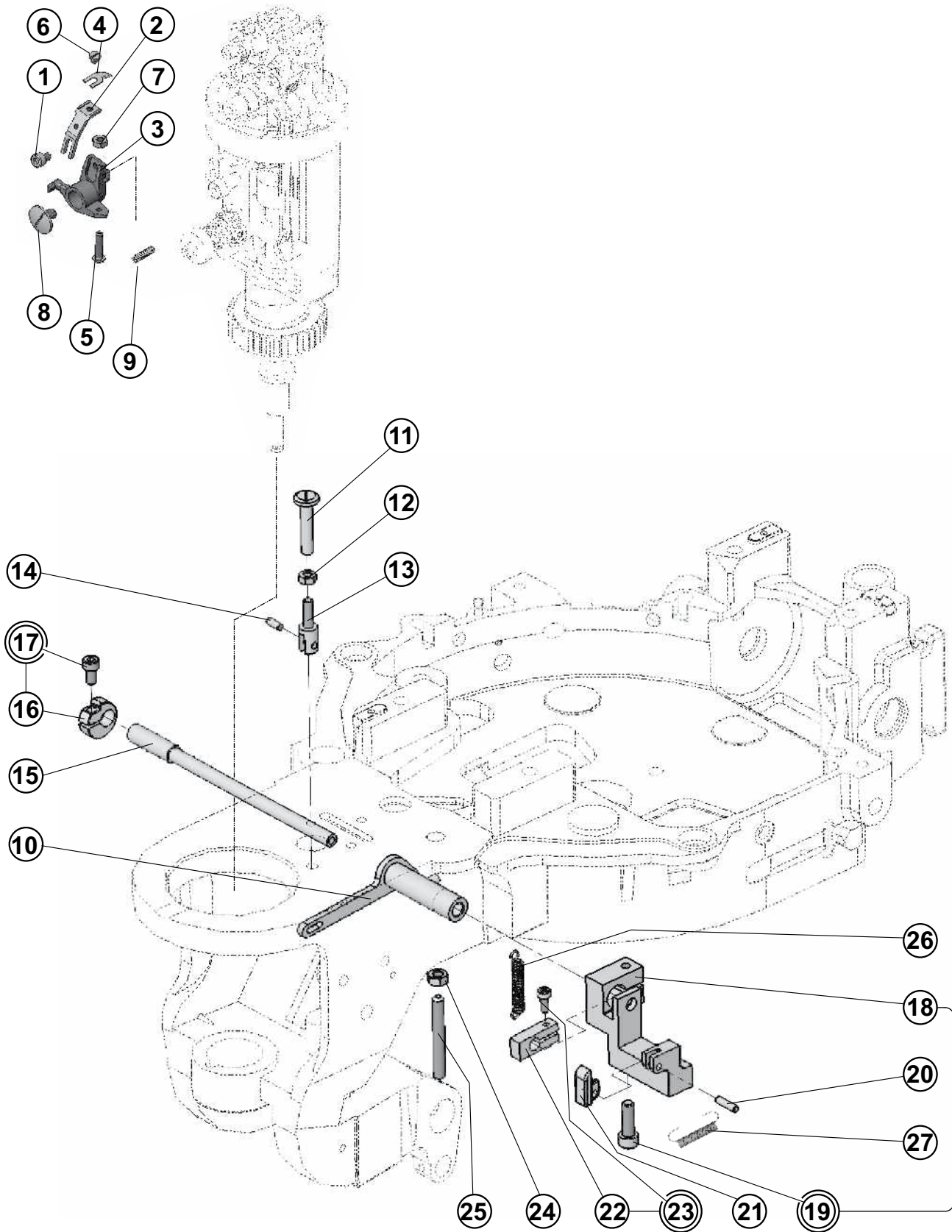

UPPER THREAD TRIMMER AND THREAD GUIDE

DET	PART NUMBER	DESCRIPTION	QTY.
01	08.6000.3.005	SCREW M3-5	1
02	11.1198.0.000	KNIFE HOLDER	1
03	11.4202.0.000	LEVER	1
04	14.1197.1.000	KNIFE TRIMMER	1
05	17.0013.6.081	SCREW	1
06	17.0012.0.688	SCREW M2,5-3,5	1
07	08.6700.3.000	NUT M3	1
08	17.0012.4.042	SCREW M4	1
09	01.5041.0.000	SPRING - EXTENSION	1
10	11.3085.0.000	TRIMMING LEVER - ASSEMBLY	1
11	11.3206.0.000	ACTUATOR	1
12	08.6700.4.000	NUT M4	1
13	11.3205.0.000	CLAVIS	1
14	12.1010.0.308	PIN 3-8	1
15	11.5019.0.000	SHAFT	1
16	18.0043.6.284	COLLAR	1
17	08.6000.4.008	SCREW M4-8	(1)
18	11.3087.0.000	HOLDER	1
19	08.6000.5.016	SCREW M5-16	(1)
20	12.1010.0.312	PIN 3-12	1
21	10.3089.2.000	LATCH	1
22	11.3088.0.000	CLAMP	1
23	08.6000.3.008	SCREW M3-8	(1)
24	08.6400.5.040	SCREW M5-40	1
25	08.6700.5.000	NUT M5	1
26	01.5134.0.000	SPRING - EXTENSION	1
27	01.5433.0.000	SPRING - EXTENSION	1

BUTTONHOLE SHAPE CHANGE

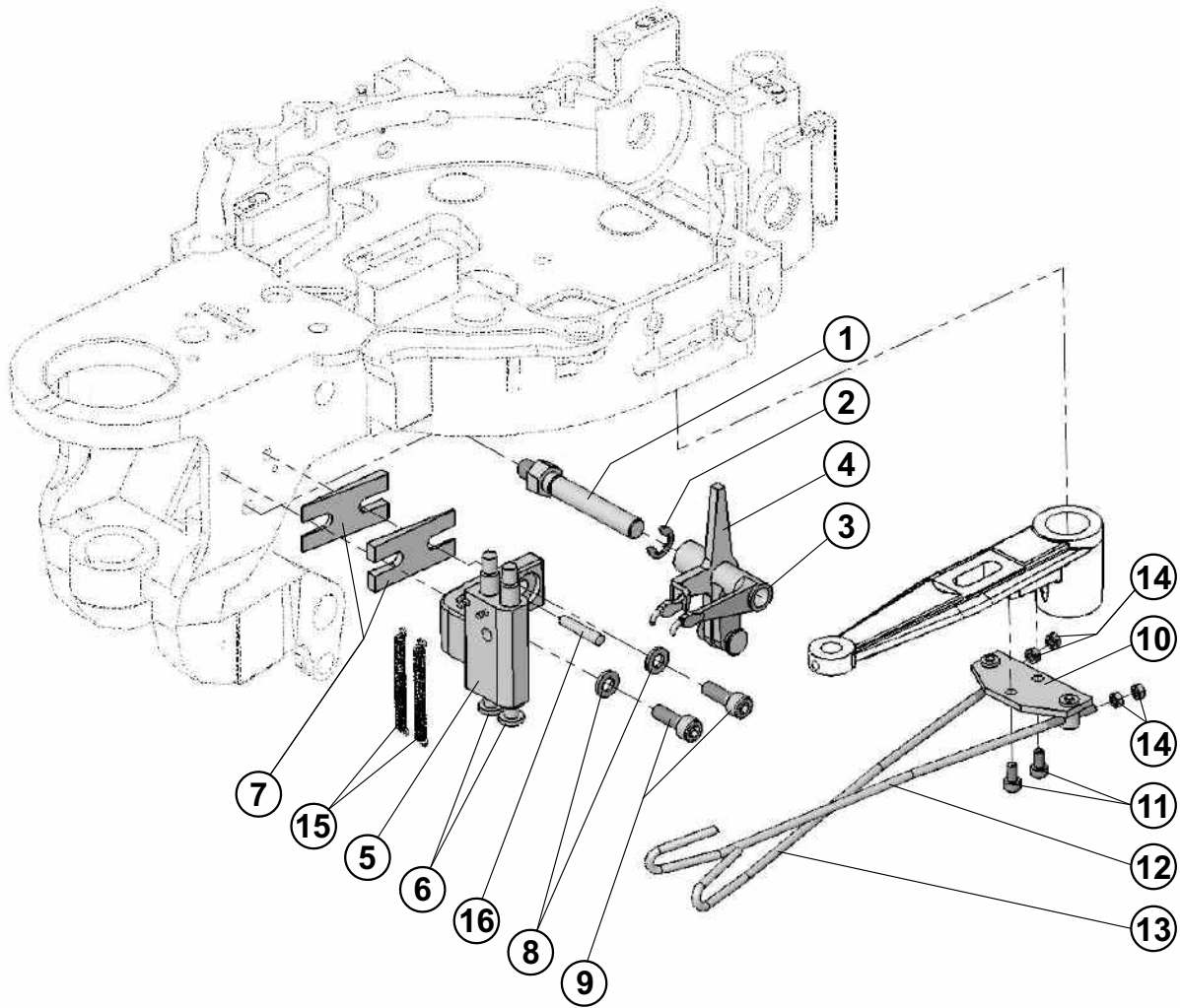

TURNING ASSEMBLY

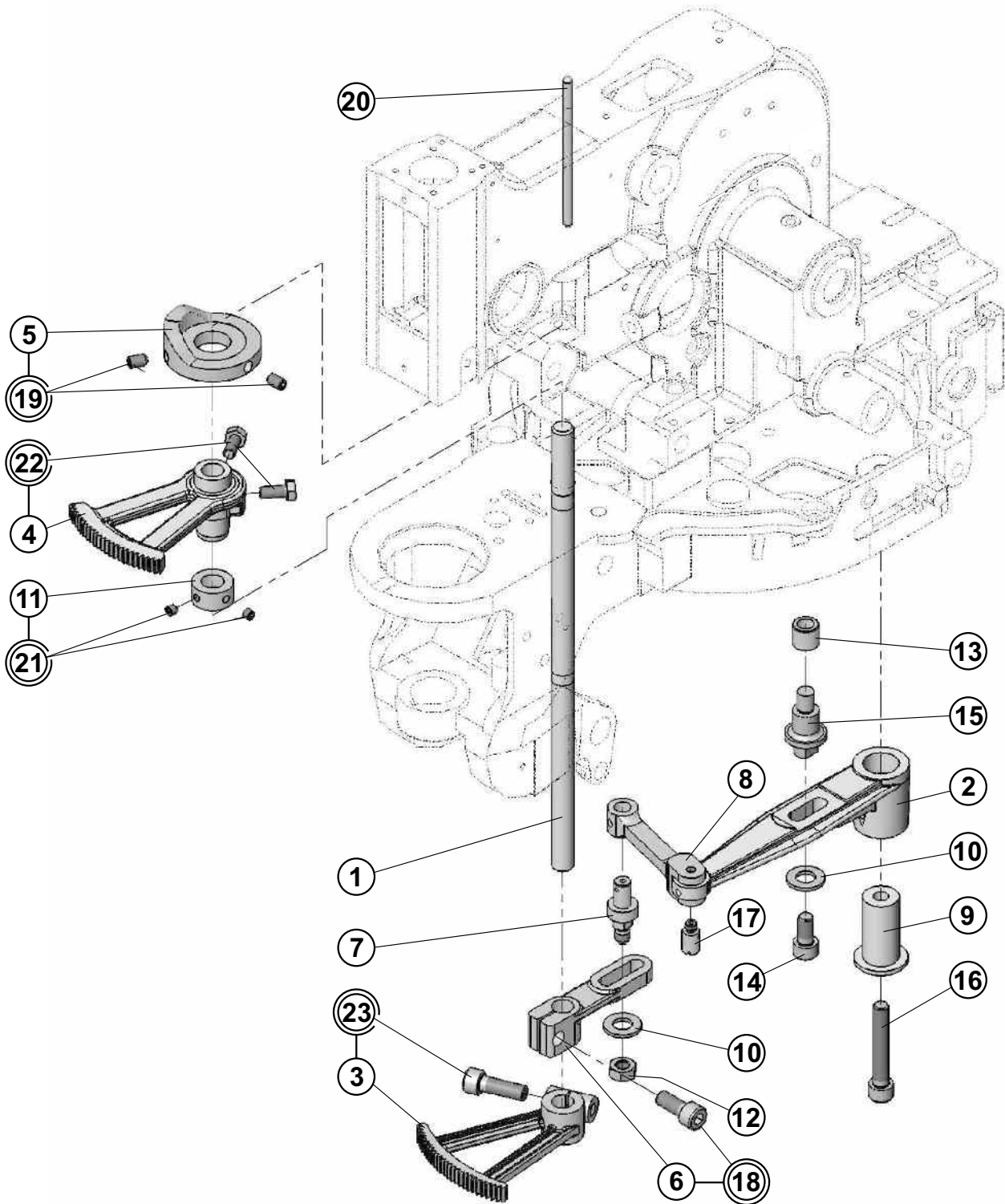

TURNING ASSEMBLY

DET	PART NUMBER	DESCRIPTION	QTY.
01	11.3009.0.000	SECTOR SHAFT	1
02	11.3015.0.000	LEVER SECTOR	1
03	17.0055.3.025	GEAR SECTOR - UNDER	1
04	11.1075.0.000	GEAR SECTOR - UPPER	1
05	11.1160.0.000	CAM	1
06	17.0063.6.308	LEVER REVERSE	1
07	17.0033.3.132	PLUG	1
08	17.0063.6.044	FORK	1
09	11.3016.0.000	BUSHING	1
10	08.6850.8.000	WASHER 8	2
11	17.0043.6.018	COLLAR RING	1
12	08.6700.8.000	NUT M8	1
13	17.0041.8.181	ROLL 14J5/9H5-12	1
14	08.6000.8.016	SCREW M8-16	1
15	11.3017.0.000	STUD	1
16	08.6000.8.050	SCREW M8-50	1
17	17.0033.1.153	SCREW	1
18	08.6000.8.020	SCREW M8-20	(1)
19	08.6400.6.010	SCREW M6-10	(2)
20	01.6334.0.000	ROD	1
21	08.6400.5.305	SCREW M5x0,5-5	(2)
22	17.0014.1.133	SCREW M6-14	(2)
23	08.6000.8.025	SCREW M8-25	(1)

CUTTING LEVER ASSEMBLY

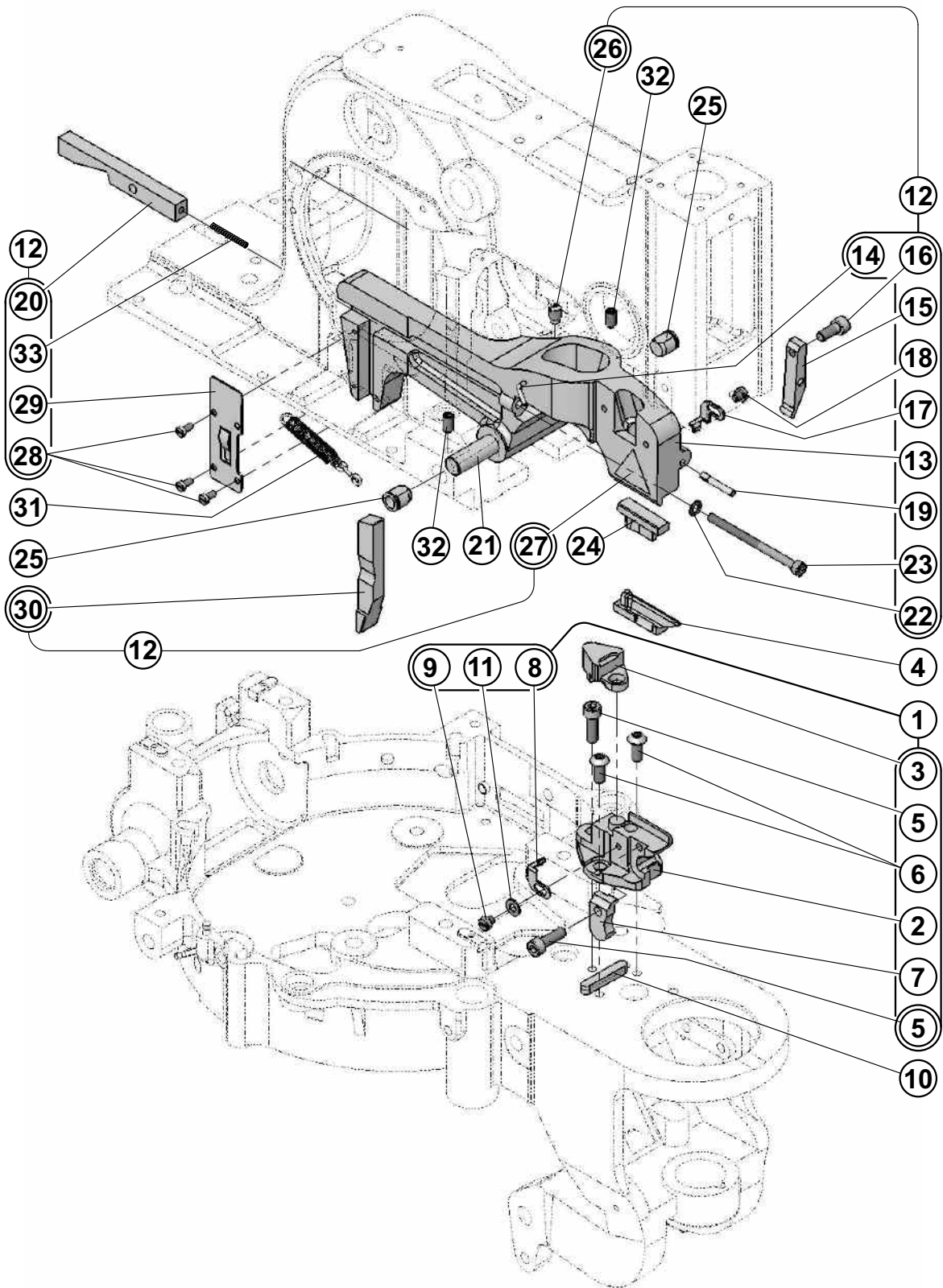

CUTTING LEVER ASSEMBLY

DET	PART NUMBER	DESCRIPTION	QTY.
01	11.3070.0.050	KNIFE HOLDER - ASSEMBLY	1
02	11.3070.0.000	KNIFE HOLDER	(1)
03	11.3067.0.000	WEDGE-SPREADER	(1)
04	11.0087.0.432	KNIFE 28x42-38	1
04	11.0087.0.434	KNIFE 34x42-38	1
05	08.6000.5.016	SCREW M5-16	(2)
06	08.6200.5.012	SCREW M5-12	(6)
07	17.0064.6.416	KNIFE CLAMP	(1)
08	17.0082.5.997	CLAMP	(1)
09	17.0012.0.571	SCREW	(1)
10	17.0021.1.073	KEY	1
11	08.6850.4.000	WASHER M4	(1)
12	11.1068.0.050	CUTTING LEVER - ASSEMBLY	1
13	11.1068.0.000	CUTTING LEVER	(1)
14	17.0031.0.405	PIN 2-20	(1)
15	17.0063.6.220	KNIFE HOLDER	(1)
16	08.6000.5.012	SCREW M5-12	(1)
17	17.0082.5.997	CLAMP	(1)
18	17.0012.0.571	SCREW	(1)
19	01.6837.0.000	PIN-GROOVED	(1)
20	11.1072.0.000	PRESSURE BAR	(1)
21	11.1074.0.000	SHAFT	1
22	08.6832.4.000	WASHER M4	(1)
23	08.6000.4.060	SCREW M4-60	(1)
24	11.0064.5.850	CUTTING STEEL 18 L	1
25	14.1025.3.000	BUTTON UNI	2
26	17.0011.2.063	SCREW M6x0,75-10	(1)
27	12.8000.0.409	LABEL ●●●	(1)
28	08.6010.3.006	SCREW M3-6	(3)
29	17.0082.5.108	COVER PLATE	(1)
30	11.1071.0.000	CAM FOLLOWER PIN	(1)
31	01.5006.0.001	SPRING - ASSEMBLY	1
32	08.6400.5.008	SCREW M5-8	2
33	17.0026.1.082	SPRING - COMPRESSION	(1)

TABLE SIDE MOVEMENT

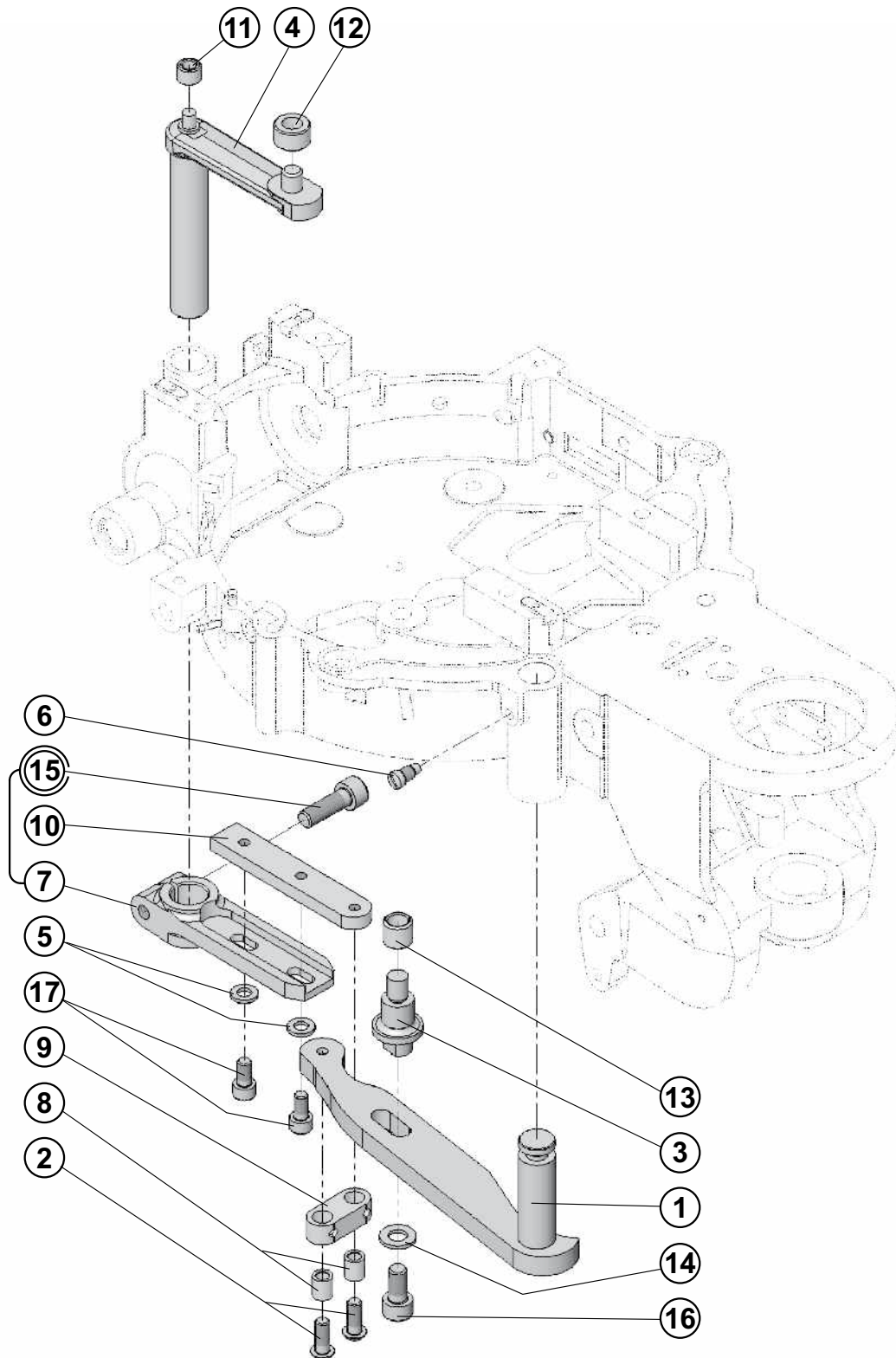

SEWING OPERATION, FLY BAR

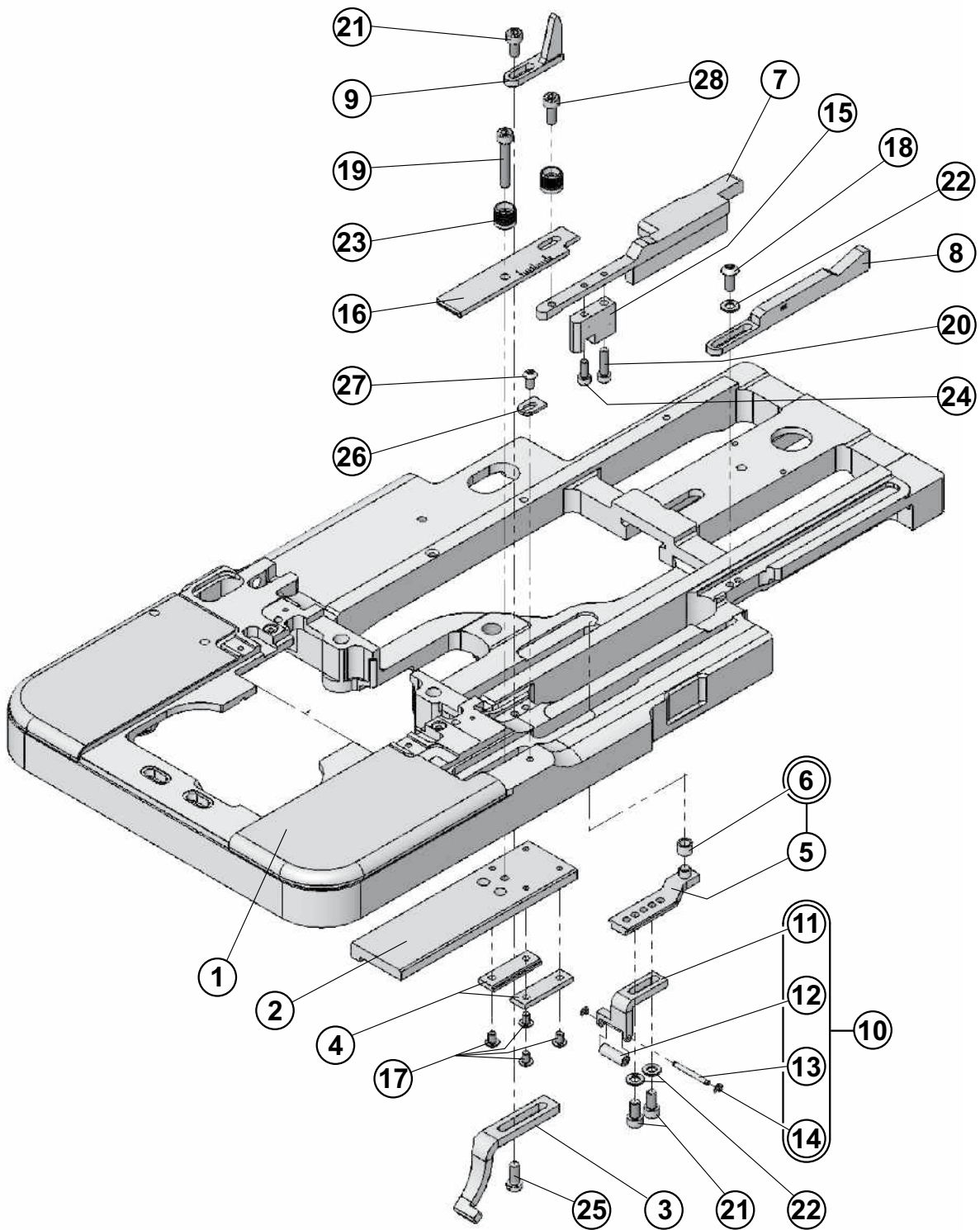

SEWING OPERATION, FLY BAR

DET	PART NUMBER	DESCRIPTION	QTY.
01	11.2001.0.000	BEDPLATE MILLING ●	1
02	11.2255.0.000	PLATE - CAM FLY BAR	1
03	11.2256.0.000	BRACKET	1
04	10.2264.0.000	GUIDE PLATE	2
05	11.2263.0.000	LINK	1
06	11.2263.0.901	ROLL ●●●	(1)
07	11.2018.0.000	LENGTH GUIDE	1
08	11.2061.0.000	WEDGE STITCH INCREASE	1
09	11.2016.0.000	BUMPER	1
10	11.2069.0.050	TRIP BRACKET - ASSEMBLY	1
11	11.2069.0.000	TRIP BRACKET	(1)
12	11.2069.0.902	TRIP ROLLER	(1)
13	11.2069.0.901	PIN-PIVOT	(1)
14	01.6280.0.000	RETAINING RING	(2)
15	11.2262.0.000	BLOCK	1
16	11.2251.0.000	LENGTH PLATE	1
17	08.6200.4.006	SCREW M4-6	4
18	08.6200.5.012	SCREW M5-12	1
19	08.6000.5.030	SCREW M5-30	1
20	08.6000.4.016	SCREW M4-16	1
21	08.6000.5.010	SCREW M5-10	3
22	08.6850.5.000	WASHER 5,3	3
23	11.2254.0.000	BUTTON	2
24	08.6000.4.010	SCREW M4-10	1
25	08.6010.5.012	SCREW M5-12	1
26	17.0081.5.047	STOP	1
27	08.6200.4.008	SCREW M4-8	1
28	08.6000.5.012	SCREW M5-12	1

STARTING LEVER

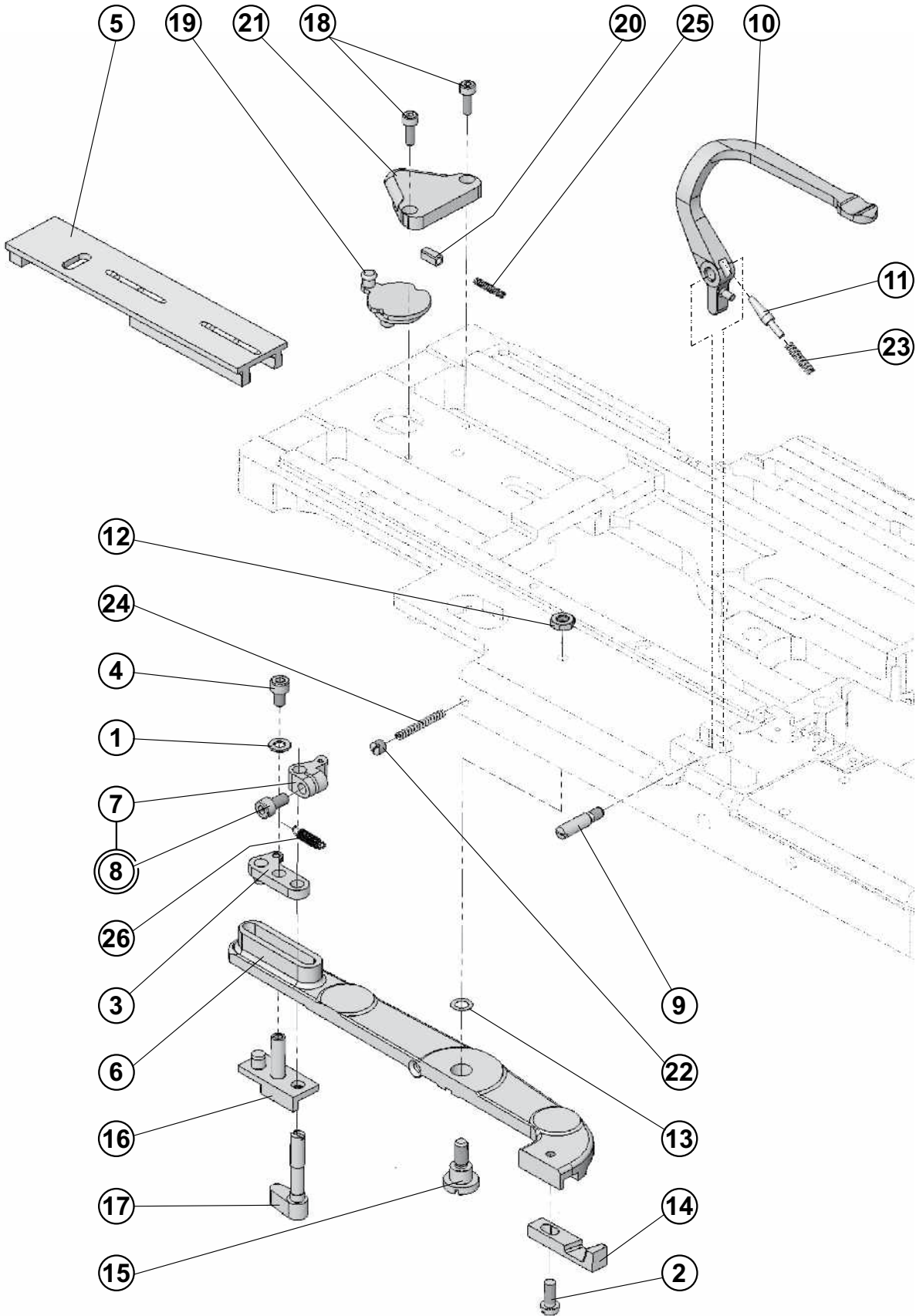

STARTING LEVER

DET	PART NUMBER	DESCRIPTION	QTY.
01	08.6850.5.000	WASHER 5,3	1
02	08.6010.5.012	SCREW M5-12	1
03	10.2072.0.000	MAKE ASSEMBLY PLATE	1
04	08.6000.5.008	SCREW M5-8	1
05	10.2260.0.001	PLATE-GUIDE	1
06	11.2012.0.000	SWITCH LEVER	1
07	11.2073.0.000	LATCH	1
08	08.6000.5.010	SCREW M5-10	(1)
09	17.0033.1.010	PLUG	1
10	11.2013.0.000	STARTING LEVER	1
11	10.2015.0.000	PLUNGER	1
12	17.0016.1.141	NUT M6 LOW	1
13	11.2090.0.000	WASHER	1
14	17.0062.5.015	TRIP	1
15	17.0033.2.030	SCREW	1
16	11.2070.0.000	BLOCK - ASSEMBLY OF	1
17	10.2071.0.000	LEVER	1
18	08.6000.4.012	SCREW M4-12	2
19	10.2257.0.000	SHIFTER	1
20	10.2259.0.000	PLUNGER	1
21	10.2258.0.000	COVER	1
22	17.0011.1.148	SET - SCREW	1
23	01.5020.0.000	SPRING - COMPRESSION	1
24	01.5019.0.000	SPRING - COMPRESSION	1
25	01.5003.0.000	SPRING - COMPRESSION	1
26	01.5473.0.000	SPRING - EXTENSION	1

CLAMP YOKE, SHIFTING LEVER

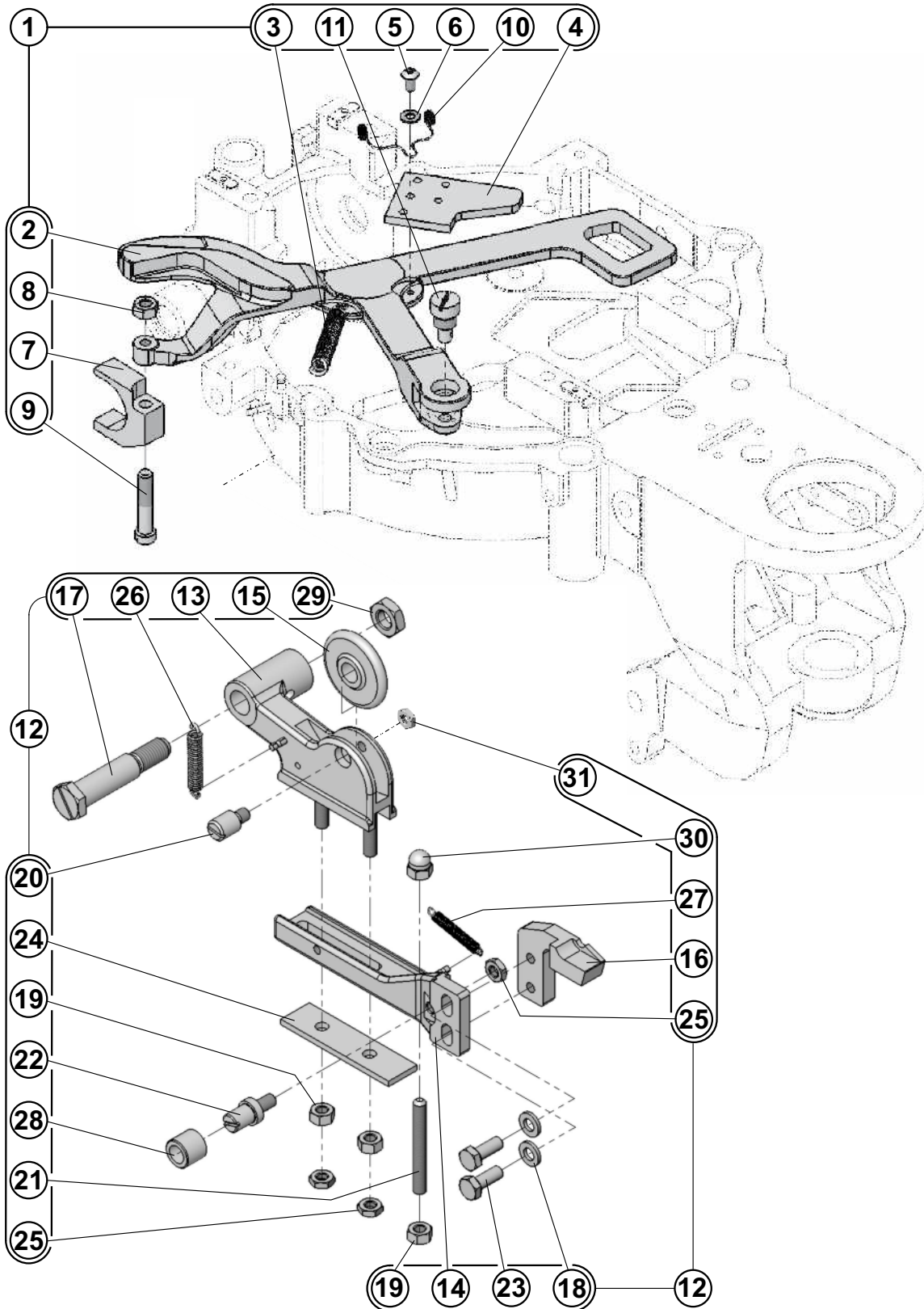

SPREADING

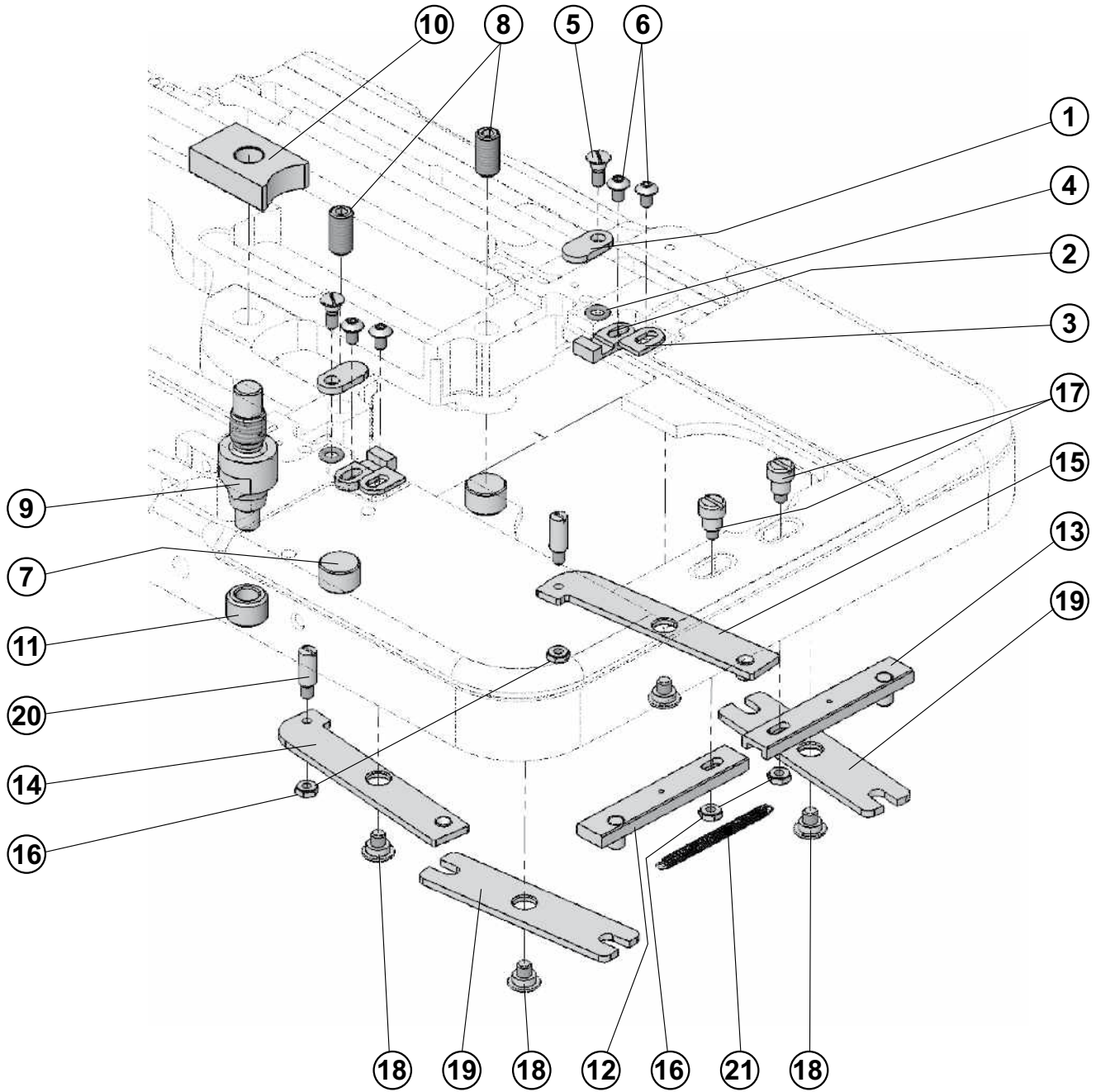

CLAMPING MECHANISM

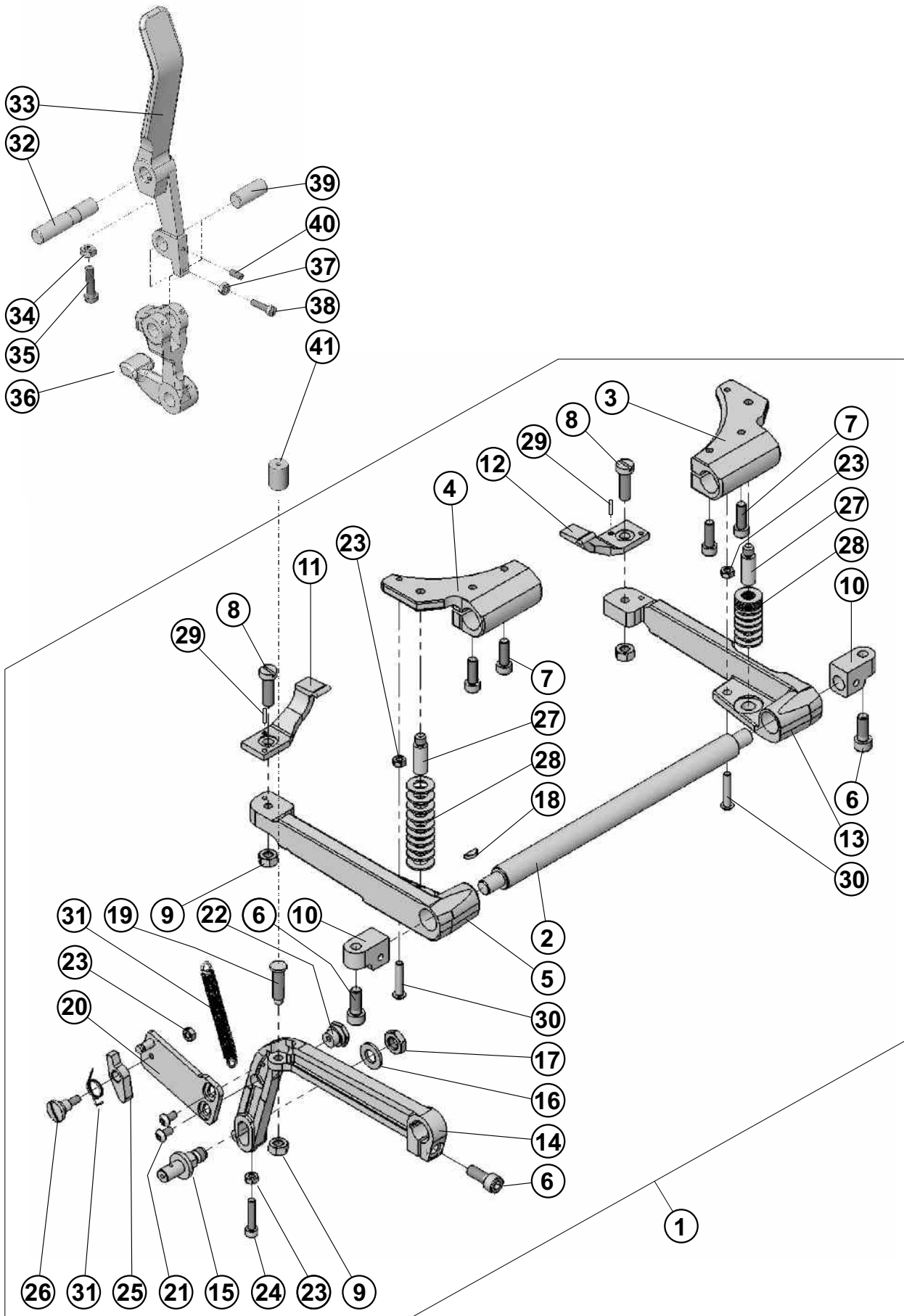

CLAMPING MECHANISM

DET	PART NUMBER	DESCRIPTION	QTY.
01	11.2026.0.050	COMPENSATING CLAMP	1
02	17.0034.2.324	SHAFT	(1)
03	11.2026.0.002	CLAMP ARM TOGGLE,R.H.	(1)
04	11.2026.0.003	CLAMP ARM TOGGLE,L.H.	(1)
05	11.2026.0.005	CLAMP YOKE LH	(1)
06	08.6000.6.016	SCREW M6-16	(3)
07	08.6000.5.016	SCREW M5-16	(4)
08	17.0012.0.254	SCREW	(2)
09	08.6700.6.000	NUT M6	(3)
10	11.2025.0.000	BEARING	(2)
11	11.2028.0.000	L.H. PULL DOWN	(1)
12	11.2027.0.000	R.H. PULL DOWN	(1)
13	11.2026.0.006	CLAMP YOKE RH	(1)
14	11.2023.0.000	CLOSING LEVER	(1)
15	17.0033.3.133	STUD	(1)
16	08.6850.8.000	WASHER 8	(1)
17	08.6710.8.000	NUT M8	(1)
18	17.0021.1.050	KEY 2,5x3,7	(1)
19	11.2086.0.000	ADJUSTABLE SCREW	(1)
20	11.2074.0.000	BRECKET	(1)
21	08.6200.4.008	SCREW M4-8	(2)
22	11.2088.0.000	ECCENTRIC NUT	(1)
23	08.6700.4.000	NUT M4	(4)
24	08.6000.4.020	SCREW M4-20	(1)
25	10.2075.0.000	LATCH	(1)
26	11.2089.0.000	SCREW-SHOULDER	(1)
27	11.2024.0.000	PIN	(2)
28	01.4121.0.000	WASHER	(20)
29	12.1014.0.308	PIN 3-8	(2)
30	11.2087.0.000	SCREW M4-22	(2)
31	01.5475.0.000	SPRING - EXTENSION	(1)
32	17.0033.5.052	PLUG	1
33	17.0061.5.027	LEVER	1
34	08.6700.4.000	NUT M4	1
35	08.6010.4.016	SCREW M4-16	1
36	11.2021.0.000	LEVER - TOGGLE	1
37	08.6700.3.000	NUT M3	1
38	08.6010.3.012	SCREW M3-12	1
39	17.0031.4.030	STUD	1
40	08.6400.3.010	SCREW M3-10	1
41	13.2087.1.000	BUMPER	1
42	08.6700.6.300	NUT M6x0,75	●●● (2)

CLAMP PLATE ASSEMBLY

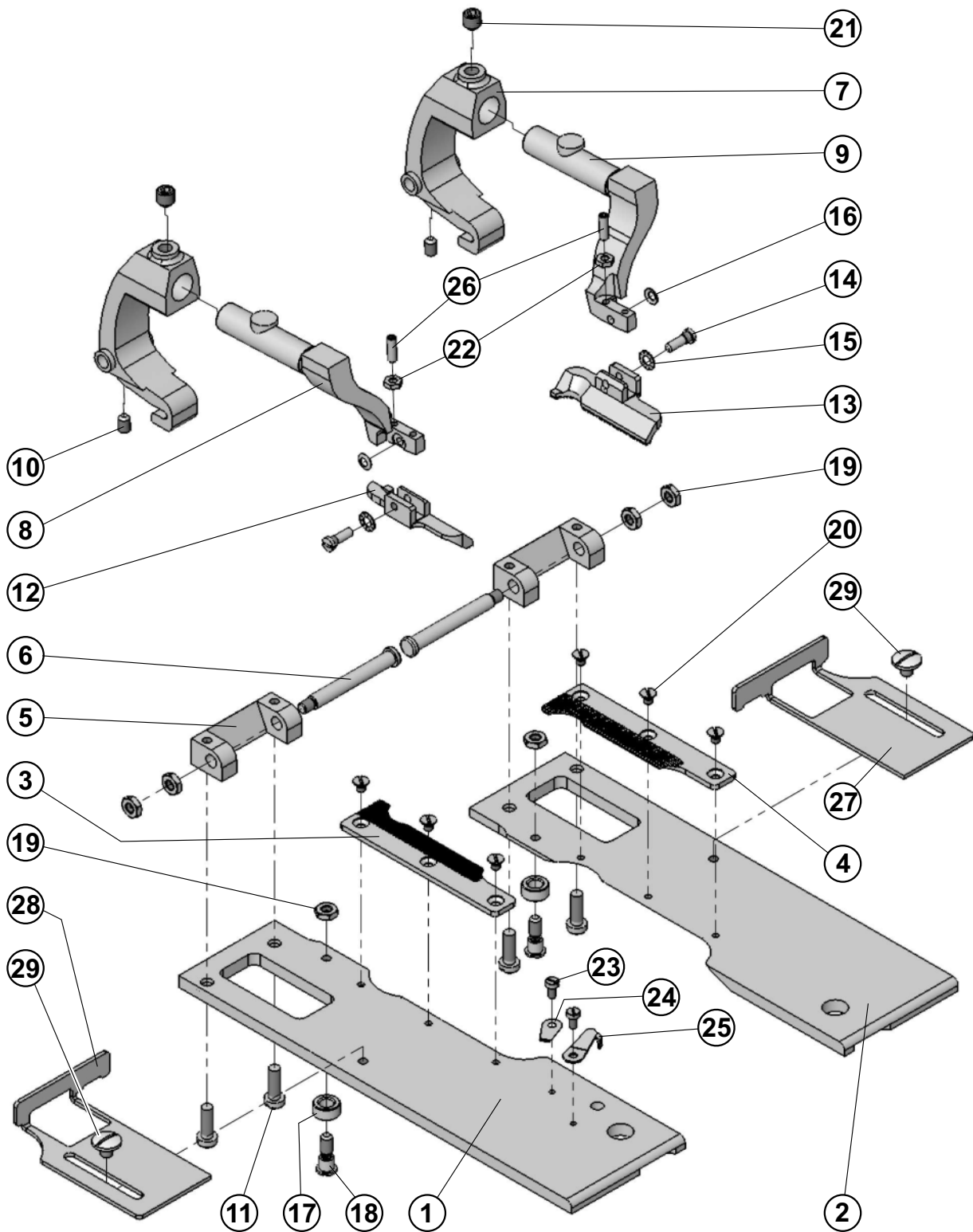

CLAMP PLATE ASSEMBLY

DET	PART NUMBER	DESCRIPTION	QTY.
01	11.2047.0.000	PLATE-CLAMP, L.H.	1
02	11.2043.0.000	PLATE-CLAMP, R.H.	1
03	11.2048.0.000	MAT CLAMP LH - 32	1
04	11.2044.0.000	MAT CLAMP RH - 32	1
05	11.2005.0.000	BLOCK	2
06	19.0032.8.401	SHAFT	2
07	11.2002.0.000	BASE CLAMP ARM	2
08	11.2004.0.000	ARM CLAMP L.H. SMALL	1
09	11.2003.0.000	ARM CLAMP R.H. SMALL	1
10	08.6400.4.006	SCREW M4-6	2
11	08.6010.4.012	SCREW M4-12	4
12	19.0066.7.421	CLAMP FOOT LEFT	1
13	19.0066.7.420	CLAMP FOOT RIGHT	1
14	17.0013.5.067	SCREW	2
15	17.0019.5.040	WASHER	2
16	17.0019.2.066	WASHER	2
17	17.0041.8.005	ROLL	2
18	17.0013.1.047	SCREW	2
19	08.6710.4.000	NUT M4	6
20	08.6112.3.004	SCREW M3x4	6
21	08.6400.6.006	SCREW M6-6	2
22	08.6710.3.000	NUT M3	2
23	17.0012.0.303	SCREW M2,5-5	2
24	17.0082.5.884	CLIPS	1
25	17.0087.0.169	KNIFE	1
26	08.6400.3.010	SCREW M3-10	2
27	14.2059.0.000	CLOTH GAUGE R.H.	1
28	14.2060.0.000	CLOTH GAUGE L.H.	1
29	17.0012.4.106	SCREW M4	2

COVERS

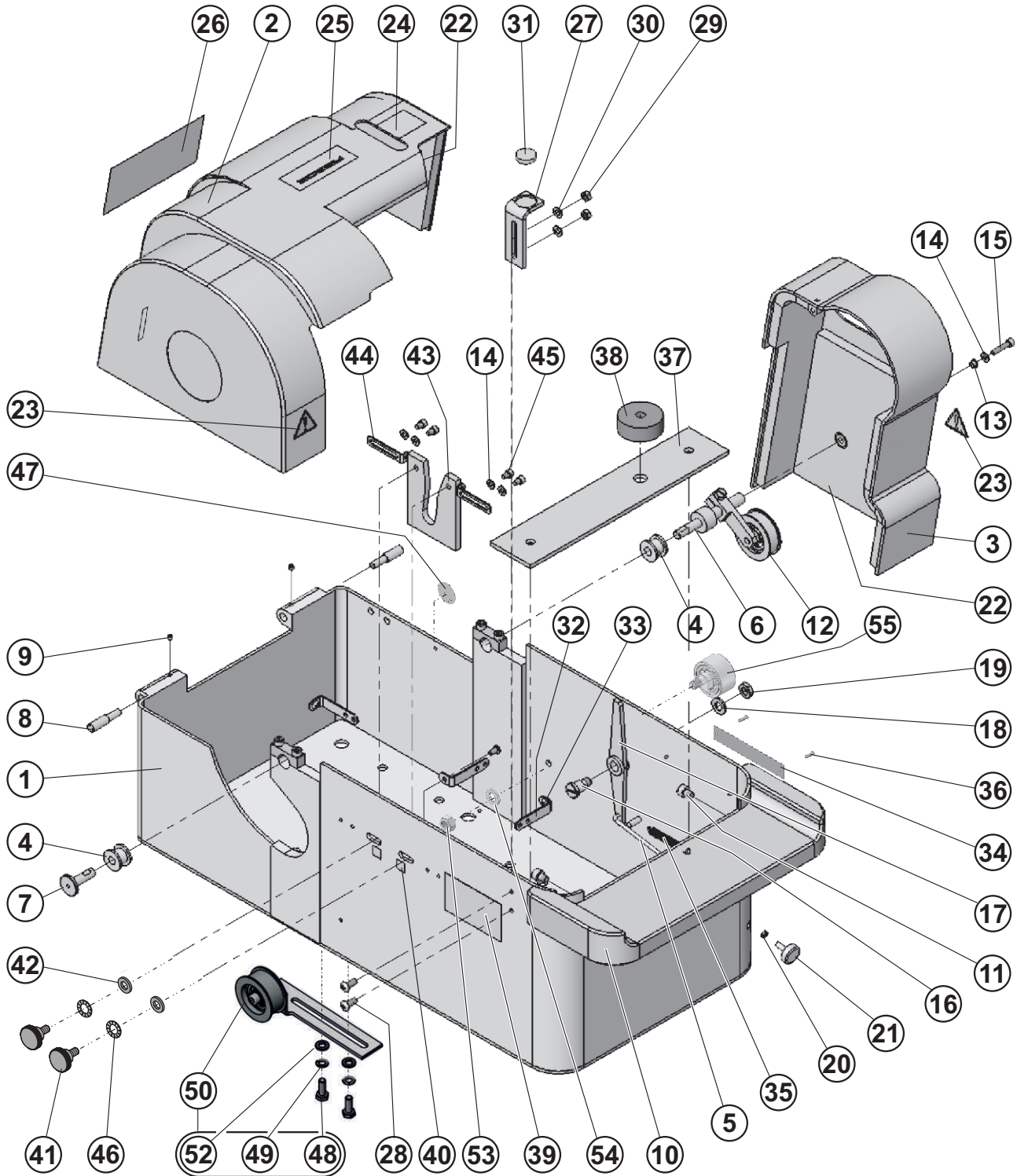

COVERS

DET	PART NUMBER	DESCRIPTION	QTY.
01	11.5001.1.000	CASE, S105	1
02	11.5021.0.000	COVER HIND	1
03	11.5022.0.000	COVER RIGHT	1
04	11.5004.0.000	BUSHING	2
05	11.5003.0.000	ROD	1
06	17.0033.2.133	BUSHING PIN	1
07	17.0032.0.193	SHAFT	1
08	19.0031.3.405	PIN	2
09	08.6400.4.005	SCREW M4-5	2
10	11.5005.0.000	CASE COVER CE	1
11	08.6000.6.008	SCREW M6-8	2
12	17.0004.3.485	ROLLER COMPLETE - ASSEMBLY	1
13	19.0095.1.408	RING	1
14	08.6850.4.000	WASHER M4	5
15	08.6000.4.020	SCREW M4-20	1
16	17.0013.1.171	SCREW M8-22	1
17	19.0063.3.403	SUPPORT	1
18	08.6850.8.000	WASHER 8	1
19	08.6712.8.000	NUT M8	1
20	08.6700.3.000	NUT M3	1
21	19.0017.2.402	BUTTON	• 1
22	11.5031.0.000	PAN ACOUSTIC	••• 1
23	17.0097.5.174	LABEL- WARNING	
24	05.9000.0.102	STICKER	
25	05.1393.0.000	LABEL	••• 1
26	05.1395.0.000	REPLACEMENT PARTS-LABEL	••• 1
27	11.5009.0.000	TABLE SUPPORT	
28	08.6200.5.012	SCREW M5-12	2
29	08.6700.5.000	NUT M5	2
30	08.6850.5.000	WASHER 5,3	2
31	19.0094.5.413	FELT	••• 1
32	05.0043.1.000	THREAD GUIDE	
33	08.6200.4.006	SCREW M4-6	3
34	12.8000.1.001	LABEL - AMF REECE	• 1
35	17.0026.3.014	SPRING	1
36	12.1016.0.002	NAIL 1,86x6,35	2
37	11.5007.0.000	PLATE	••• 1
38	19.0095.1.405	RUBBER	••• 1
39	12.8000.0.416	LABEL CE UNI	••• 1
40	12.8000.0.107	LABEL CB - CA	••• 1
41	17.0013.3.402	SCREW M6	2
42	17.0019.0.232	WASHER	2
43	11.5011.0.000	GUIDE	1
44	22.0046.0.000	THREAD GUIDE BRACKET	2
45	08.6000.4.006	SCREW M4-6	4
46	08.6832.6.000	WASHER M6	2



COVERS

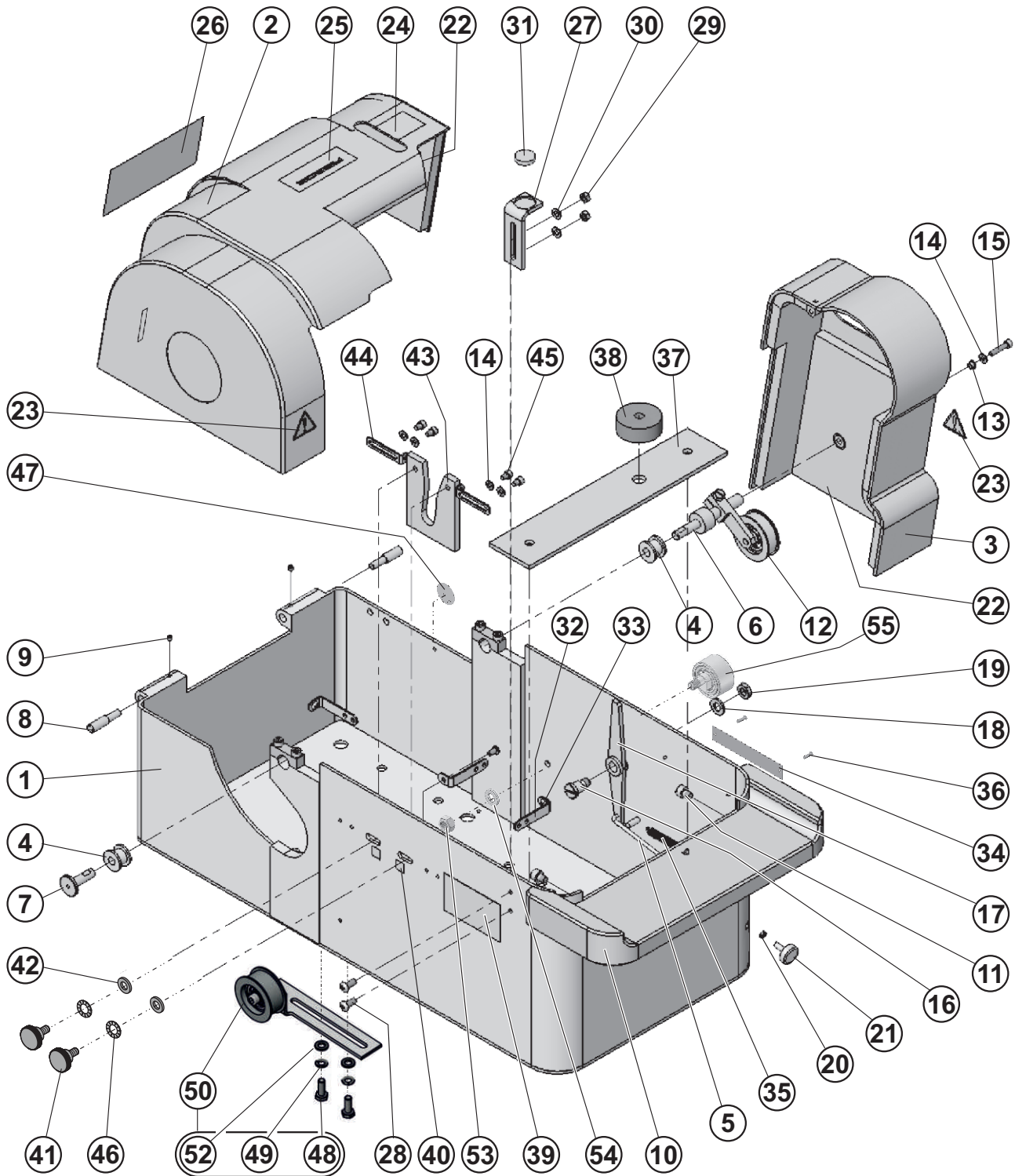

TABLE

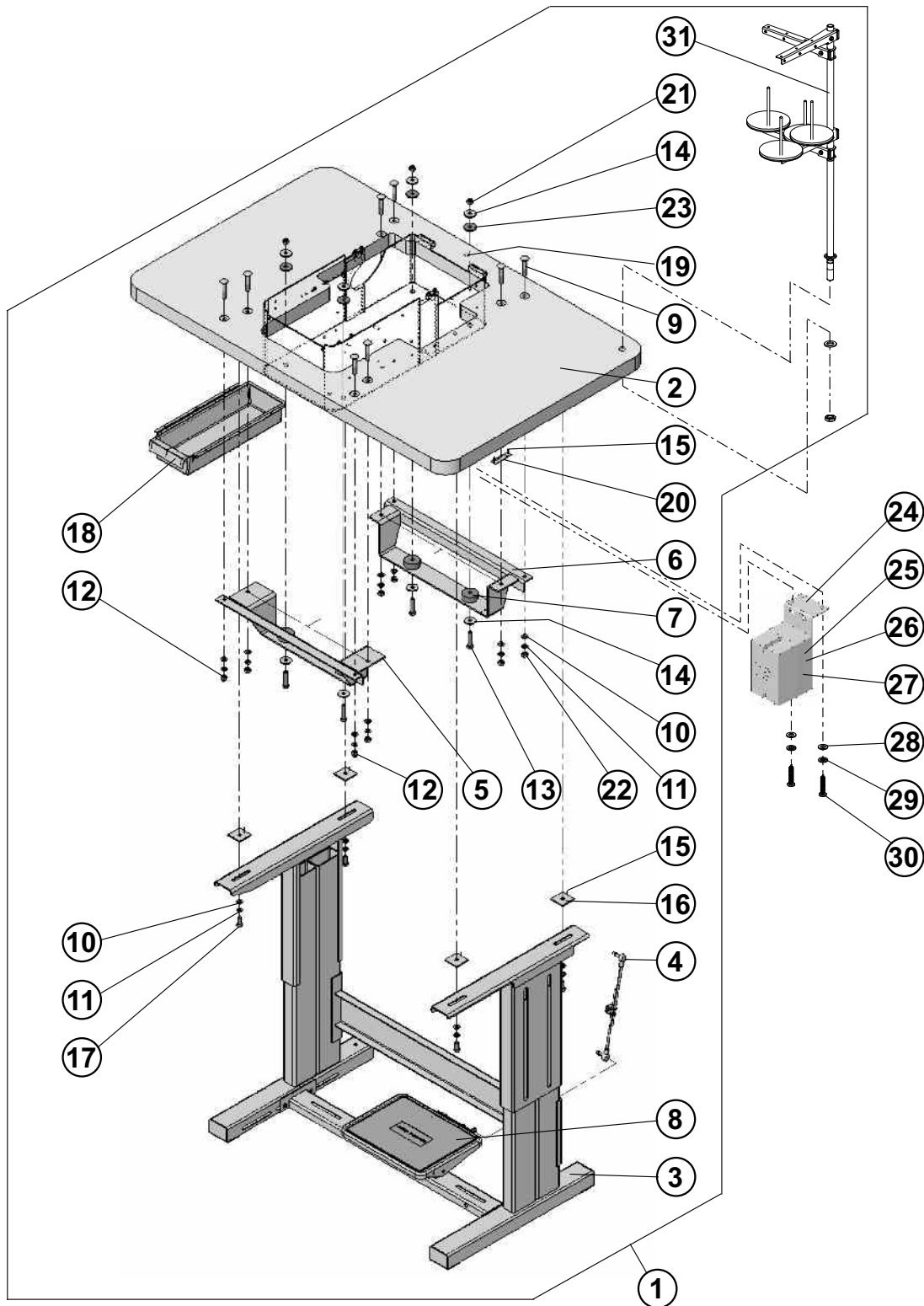

TABLE

DET	PART NUMBER	DESCRIPTION	QTY.
01	04.9011.0.021	TABLE 1 S105 - SEMIASSEMBLY	1
02	04.9011.0.001	TABLE TOP 1, S105 ●●●	(1)
03	04.9000.2.123	TABLE	(1)
04	04.1956.2.000	PITMAN ROD BAL	(1)
05	19.0005.0.015	FRAMEWORK FRONT	(1)
06	19.0005.0.016	FRAMEWORK BACK	(1)
07	19.0095.1.405	RUBBER ●●●	(4)
08	22.0218.0.000	FOOTSWITCH - ASSEMBLY	(1)
09	08.6532.8.050	SCREW M8-50	(8)
10	08.6852.8.000	WASHER M8	(12)
11	08.6802.8.000	SPRING WASHER M8	(12)
12	08.6722.8.000	NUT M8	(2)
13	08.6312.8.040	SCREW M8-40	(4)
14	17.0019.0.441	WASHER	(8)
15	12.4010.0.004	NAIL 1,6x20	(6)
16	17.0094.0.200	WASHER ●●●	(4)
17	08.6312.8.020	SCREW M8-20	(4)
18	12.0008.6.901	BOX ●●●	(1)
19	12.0008.6.915	HOLDERBUNPON	(1)
20	04.1416.1.003	LABEL	(1)
21	08.6733.8.000	NUT M8	(4)
22	08.6702.8.000	NUT M8	(6)
23	17.0095.1.272	RUBBER WASHER	(4)
24	17.0083.6.357	BRACKET	1
25	12.0008.4.206	BOX SM-SM1-M ●●●	1
26	12.0008.4.285	UNDERVOLT.TRIP 230VAC ●●●	1
27	12.0010.4.141	MOTOR CIRCUIT BREAKER ●●●	1
28	08.6850.6.000	WASHER 6,4	2
29	08.6800.6.000	WASHER 6	2
30	08.6310.6.016	SCREW M6-16	2
31	17.0003.6.156	THRED STAND - ASSEMBLY ●●●	(1)

DRIVE

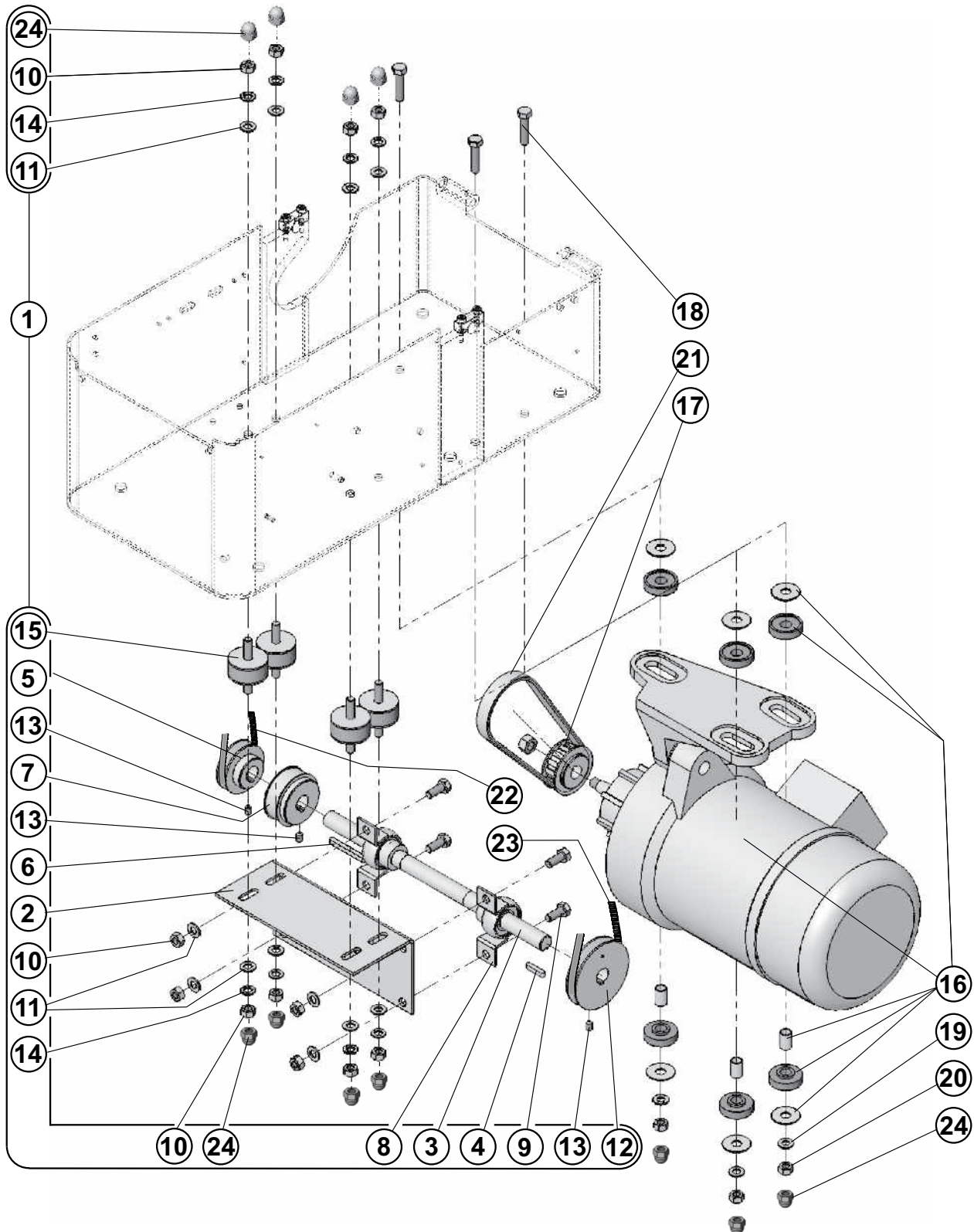

ACCESSORIES

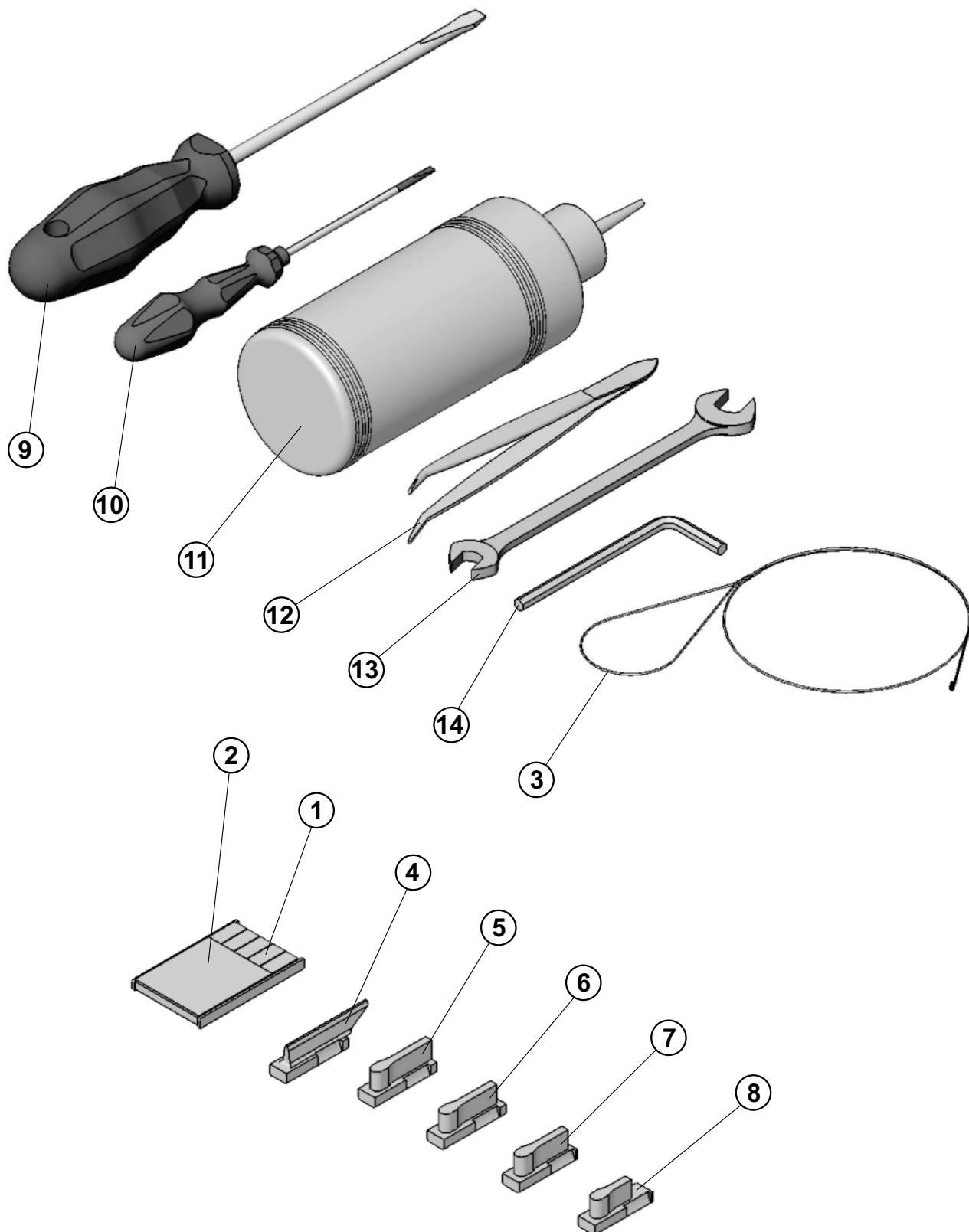

INDEX

PART NUMBER	PAGE	DET	QTY	PART NUMBER	PAGE	DET	QTY	PART NUMBER	PAGE	DET	QTY
01.1100.0.000	3-3	22	1	04.9000.2.123	3-61	3	(1)	08.6000.5.016	3-41	5	(2)
01.1113.0.000	3-13	11	1	04.9001.2.050	3-59	50	1	08.6000.5.016	3-53	7	(4)
01.2056.1.000	3-21	37	1	04.9011.0.001	3-61	2	(1)	08.6000.5.020	3-3	31	1
01.2075.0.000	3-25	20	(2)	04.9011.0.021	3-61	1	1	08.6000.5.020	3-25	8	(1)
01.4007.0.000	3-25	38	2	05.0043.1.000	3-13	17	1	08.6000.5.020	3-29	7	(1)
01.4074.0.000	3-13	5	1	05.0043.1.000	3-57	32	3	08.6000.5.030	3-45	19	1
01.4081.0.005	3-21	45	1	05.0144.0.000	3-49	30	(1)	08.6000.5.050	3-27	13	1
01.4081.0.009	3-9	6	(1)	05.0413.0.000	3-3	36	1	08.6000.6.008	3-57	11	2
01.4121.0.000	3-53	28	(20)	05.1105.0.000	3-19	8	2	08.6000.6.012	3-43	17	2
01.4426.0.000	3-51	4	2	05.1389.0.000	3-3	14	1	08.6000.6.012	3-59	48	(2)
01.4751.0.000	3-15	4	(2)	05.1393.0.000	3-57	25	1	08.6000.6.016	3-11	14	(1)
01.5002.0.000	3-13	27	1	05.1395.0.000	3-57	26	1	08.6000.6.016	3-53	6	(3)
01.5003.0.000	3-9	27	(2)	05.9000.0.102	3-57	24	1	08.6000.6.018	3-37	9	2
01.5003.0.000	3-47	25	1	07.0401.0.000	3-23	54	1	08.6000.8.016	3-39	14	1
01.5005.0.001	3-15	9	1	07.0401.0.009	3-19	14	1	08.6000.8.016	3-43	16	1
01.5006.0.001	3-41	31	1	08.6000.3.005	3-35	1	1	08.6000.8.020	3-39	18	(1)
01.5015.0.000	3-49	26	(1)	08.6000.3.006	3-13	21	1	08.6000.8.025	3-39	23	(1)
01.5019.0.000	3-47	24	1	08.6000.3.008	3-21	34	2	08.6000.8.025	3-43	15	(1)
01.5020.0.000	3-47	23	1	08.6000.3.008	3-35	23	(1)	08.6000.8.050	3-39	16	1
01.5023.0.000	3-51	21	1	08.6000.3.010	3-9	8	(1)	08.6000.8.055	3-3	7	4
01.5026.0.000	3-21	48	2	08.6000.4.005	3-21	36	1	08.6010.3.006	3-19	15	2
01.5041.0.000	3-35	9	1	08.6000.4.006	3-57	45	4	08.6010.3.006	3-21	12	4
01.5054.0.000	3-37	15	2	08.6000.4.008	3-35	17	(1)	08.6010.3.006	3-25	25	(2)
01.5055.0.000	3-31	27	1	08.6000.4.008	3-37	11	2	08.6010.3.006	3-41	28	(3)
01.5055.0.000	3-49	3	(1)	08.6000.4.010	3-3	15	4	08.6010.3.012	3-53	38	1
01.5055.0.051	3-31	9	1	08.6000.4.010	3-23	53	(1)	08.6010.4.012	3-21	24	2
01.5134.0.000	3-35	26	1	08.6000.4.010	3-27	04	(2)	08.6010.4.012	3-55	11	4
01.5163.0.000	3-13	28	1	08.6000.4.010	3-31	15	2	08.6010.4.016	3-53	35	1
01.5433.0.000	3-35	27	1	08.6000.4.010	3-45	24	1	08.6010.5.012	3-45	25	1
01.5447.0.000	3-29	4	(1)	08.6000.4.012	3-47	18	2	08.6010.5.012	3-47	2	1
01.5448.0.000	3-29	12	(1)	08.6000.4.016	3-3	11	2	08.6032.4.010	3-13	18	1
01.5473.0.000	3-3	21	1	08.6000.4.016	3-13	26	2	08.6100.5.010	3-31	25	2
01.5473.0.000	3-47	26	1	08.6000.4.016	3-45	20	1	08.6112.3.004	3-55	20	6
01.5475.0.000	3-53	31	(1)	08.6000.4.020	3-53	24	(1)	08.6200.4.006	3-11	16	1
01.5602.0.000	3-49	27	(1)	08.6000.4.020	3-57	15	1	08.6200.4.006	3-25	26	(4)
01.5603.0.000	3-13	29	1	08.6000.4.025	3-21	29	1	08.6200.4.006	3-45	17	4
01.5683.0.000	3-25	34	3	08.6000.4.040	3-31	11	(1)	08.6200.4.006	3-51	6	4
01.6280.0.000	3-45	14	(2)	08.6000.4.045	3-19	5	1	08.6200.4.006	3-57	33	3
01.6334.0.000	3-39	20	1	08.6000.4.060	3-41	23	(1)	08.6200.4.008	3-3	26	4
01.6837.0.000	3-41	19	(1)	08.6000.5.008	3-47	4	1	08.6200.4.008	3-45	27	1
01.6970.0.000	3-25	4	1	08.6000.5.010	3-45	21	3	08.6200.4.008	3-49	5	(1)
01.7040.0.000	3-25	24	(1)	08.6000.5.010	3-47	8	(1)	08.6200.4.008	3-53	21	(2)
01.7630.0.001	3-15	5	(1)	08.6000.5.012	3-3	35	2	08.6200.5.008	3-3	29	2
02.0558.0.111	3-9	23	1	08.6000.5.012	3-5	23	1	08.6200.5.008	3-29	6	(1)
02.0558.0.111	3-65	2	5	08.6000.5.012	3-27	19	4	08.6200.5.010	3-9	29	2
04.1416.1.003	3-61	20	(1)	08.6000.5.012	3-29	14	(2)	08.6200.5.012	3-29	25	(1)
04.1956.2.000	3-61	4	(1)	08.6000.5.012	3-41	16	(1)	08.6200.5.012	3-41	6	(6)
04.9000.0.051	3-63	1	1	08.6000.5.012	3-45	28	1	08.6200.5.012	3-45	18	1
04.9000.0.448	3-63	2	(1)	08.6000.5.016	3-25	16	(1)	08.6200.5.012	3-57	28	2
04.9000.0.449	3-63	21	1	08.6000.5.016	3-35	19	(1)	08.6200.5.020	3-13	25	1

INDEX

PART NUMBER	PAGE	DET	QTY	PART NUMBER	PAGE	DET	QTY	PART NUMBER	PAGE	DET	QTY
08.6200.6.016	3-43	2	2	08.6700.5.000	3-35	25	1	08.6850.5.000	3-45	22	3
08.6202.4.010	3-9	21	4	08.6700.5.000	3-57	29	2	08.6850.5.000	3-47	1	1
08.6300.8.020	3-27	18	2	08.6700.6.000	3-31	24	2+(1)	08.6850.5.000	3-57	30	2
08.6310.3.012	3-13	23	1	08.6700.6.000	3-49	8	(1)	08.6850.6.000	3-11	23	1
08.6310.6.016	3-49	23	(2)	08.6700.6.000	3-49	19	(3)	08.6850.6.000	3-31	19	1
08.6310.6.016	3-61	30	2	08.6700.6.000	3-53	9	(3)	08.6850.6.000	3-37	8	2
08.6312.8.020	3-61	17	(4)	08.6700.6.300	3-17	22	1	08.6850.6.000	3-43	5	2
08.6312.8.020	3-63	9	(4)	08.6700.6.300	3-27	17	8	08.6850.6.000	3-49	18	(2)
08.6312.8.040	3-61	13	(4)	08.6700.6.300	3-53	42	(2)	08.6850.6.000	3-59	52	(2)
08.6312.8.040	3-63	18	3	08.6700.6.300	3-59	53	1	08.6850.6.000	3-59	54	1
08.6400.3.005	3-9	33	(2)+1	08.6700.8.000	3-39	12	1	08.6850.6.000	3-61	28	2
08.6400.3.010	3-53	40	1	08.6702.8.000	3-61	22	(6)	08.6850.8.000	3-3	23	1
08.6400.3.010	3-55	26	2	08.6702.8.000	3-63	10	(12)	08.6850.8.000	3-27	21	2
08.6400.4.005	3-57	9	2	08.6702.8.000	3-63	20	3	08.6850.8.000	3-39	10	2
08.6400.4.006	3-7	6	2	08.6707.1.000	3-37	14	4	08.6850.8.000	3-43	14	1
08.6400.4.006	3-17	26	1	08.6710.0.300	3-49	29	(1)	08.6850.8.000	3-53	16	(1)
08.6400.4.006	3-55	10	2	08.6710.3.000	3-55	22	2	08.6850.8.000	3-57	18	1
08.6400.4.008	3-17	11	1	08.6710.4.000	3-55	19	6	08.6852.8.000	3-61	10	(12)
08.6400.5.005	3-21	39	1	08.6710.5.000	3-17	8	(2)	08.6852.8.000	3-63	11	(12)
08.6400.5.005	3-29	11	(1)	08.6710.5.000	3-29	8	(1)	08.6852.8.000	3-63	19	3
08.6400.5.008	3-17	25	1	08.6710.6.000	3-49	25	(3)	08.6872.0.000	3-33	5	2
08.6400.5.008	3-41	32	2	08.6710.6.300	3-49	31	(1)	10.1003.0.000	3-13	13	1
08.6400.5.010	3-11	28	(1)	08.6710.8.000	3-53	17	(1)	10.1004.0.000	3-9	18	1
08.6400.5.030	3-11	17	1	08.6710.8.400	3-17	23	1	10.1004.0.000	3-13	12	1
08.6400.5.040	3-35	24	1	08.6710.8.400	3-25	10	(1)	10.1008.0.000	3-13	20	1
08.6400.5.305	3-29	17	2	08.6710.8.400	3-27	16	2	10.1009.0.000	3-13	19	1
08.6400.5.305	3-39	21	(2)	08.6710.9.500	3-5	22	1	10.1010.0.000	3-13	6	1
08.6400.6.006	3-55	21	2	08.6712.8.000	3-57	19	1	10.1021.2.000	3-9	11	(2)
08.6400.6.010	3-25	29	1	08.6717.0.000	3-33	4	2	10.1062.0.000	3-17	19	1
08.6400.6.010	3-39	19	(2)	08.6722.8.000	3-61	12	(2)	10.1077.0.000	3-13	8	1
08.6400.6.010	3-63	13	(3)	08.6722.8.000	3-63	24	(8)+3	10.1078.1.000	3-13	9	1
08.6400.6.050	3-49	21	(1)	08.6733.8.000	3-61	21	(4)	10.1080.0.000	3-3	17	1
08.6400.8.008	3-17	18	1	08.6800.4.000	3-31	23	1	10.1083.0.000	3-13	7	1
08.6400.8.416	3-27	15	2	08.6800.6.000	3-59	49	(2)	10.1091.1.803	3-5	4	1
08.6400.8.416	3-51	8	2	08.6800.6.000	3-61	29	2	10.1145.2.000	3-3	12	1
08.6522.4.006	3-3	34	1	08.6800.8.000	3-3	24	3	10.1180.0.000	3-3	19	1
08.6532.8.050	3-61	9	(8)	08.6800.8.000	3-63	14	(8)	10.1181.0.000	3-3	20	1
08.6700.3.000	3-13	15	1	08.6800.9.000	3-5	21	1	10.2015.0.000	3-47	11	1
08.6700.3.000	3-17	4	(1)	08.6802.8.000	3-61	11	(12)	10.2031.0.000	3-51	2	2
08.6700.3.000	3-35	7	1	08.6832.4.000	3-3	13	2	10.2071.0.000	3-47	17	1
08.6700.3.000	3-53	37	1	08.6832.4.000	3-27	07	(2)	10.2072.0.000	3-47	3	1
08.6700.3.000	3-57	20	1	08.6832.4.000	3-41	22	(1)	10.2075.0.000	3-53	25	(1)
08.6700.4.000	3-31	12	(2)	08.6832.6.000	3-57	46	2	10.2257.0.000	3-47	19	1
08.6700.4.000	3-31	30	1	08.6832.8.000	3-27	23	2	10.2258.0.000	3-47	21	1
08.6700.4.000	3-35	12	1	08.6850.4.000	3-19	4	1	10.2259.0.000	3-47	20	1
08.6700.4.000	3-53	23	(4)	08.6850.4.000	3-41	11	(1)	10.2260.0.001	3-47	5	1
08.6700.4.000	3-53	34	1	08.6850.4.000	3-49	6	(1)	10.2264.0.000	3-45	4	2
08.6700.5.000	3-27	12	1	08.6850.4.000	3-57	14	5	10.3033.0.017	3-51	10	1
08.6700.5.000	3-29	26	(1)	08.6850.5.000	3-11	15	1	10.3080.0.000	3-25	18	(1)
08.6700.5.000	3-31	18	1	08.6850.5.000	3-27	20	4	10.3089.2.000	3-35	21	1

INDEX

PART NUMBER	PAGE	DET	QTY	PART NUMBER	PAGE	DET	QTY	PART NUMBER	PAGE	DET	QTY
10.3250.1.000	3-37	7	2	11.1090.0.300	3-5	1	1	11.2025.0.000	3-53	10	(2)
10.3258.0.000	3-37	10	1	11.1091.0.000	3-7	7	1	11.2026.0.002	3-53	3	(1)
10.3607.1.000	3-3	25	2	11.1094.0.000	3-5	2	1	11.2026.0.003	3-53	4	(1)
10.4010.2.000	3-21	14	1	11.1096.0.400	3-5	5	1	11.2026.0.005	3-53	5	(1)
10.4012.2.004	3-21	25	1	11.1100.0.400	3-5	3	1	11.2026.0.006	3-53	13	(1)
10.4030.0.000	3-13	14	1	11.1101.0.990	3-33	3	1	11.2026.0.050	3-53	1	1
10.4035.0.000	3-21	35	1	11.1102.0.000	3-33	1	1	11.2027.0.000	3-53	12	(1)
11.0064.5.849	3-65	8	1	11.1108.0.000	3-29	15	1	11.2028.0.000	3-53	11	(1)
11.0064.5.850	3-41	24	1	11.1109.0.000	3-29	21	1	11.2033.0.000	3-51	12	1
11.0064.5.852	3-65	7	1	11.1111.0.000	3-29	16	1	11.2034.0.000	3-51	13	1
11.0064.5.853	3-65	6	1	11.1113.0.000	3-31	1	1	11.2037.0.000	3-51	17	2
11.0064.5.854	3-65	5	1	11.1118.0.000	3-31	4	1	11.2039.0.000	3-51	14	1
11.0087.0.430	3-65	4	1	11.1120.0.000	3-31	8	1	11.2040.0.000	3-51	15	1
11.0087.0.432	3-41	4	1	11.1122.0.010	3-7	3	1	11.2043.0.000	3-55	2	1
11.0087.0.434	3-41	4	1	11.1122.0.979	3-7	0	0	11.2044.0.000	3-55	4	1
11.1001.0.000	3-3	4	1	11.1122.0.980	3-7	0	0	11.2047.0.000	3-55	1	1
11.1011.0.000	3-9	32	1	11.1122.0.980	3-17	24	1	11.2048.0.000	3-55	3	1
11.1023.0.000	3-9	4	(1)	11.1122.0.998	3-7	0	0	11.2051.0.000	3-51	5	2
11.1026.0.000	3-17	17	1	11.1122.0.999	3-7	0	0	11.2061.0.000	3-45	8	1
11.1028.0.050	3-9	1	1	11.1124.0.000	3-31	3	1	11.2069.0.000	3-45	11	(1)
11.1030.0.000	3-19	9	1	11.1158.0.000	3-13	3	1	11.2069.0.050	3-45	10	1
11.1031.0.000	3-19	10	1	11.1159.0.000	3-13	1	1	11.2069.0.901	3-45	13	(1)
11.1035.0.000	3-11	5	1	11.1160.0.000	3-39	5	1	11.2069.0.902	3-45	12	(1)
11.1037.0.000	3-11	11	1	11.1167.0.000	3-29	2	(1)	11.2070.0.000	3-47	16	1
11.1038.1.000	3-11	2	1	11.1167.0.050	3-29	1	1	11.2073.0.000	3-47	7	1
11.1039.0.000	3-11	4	1	11.1168.0.000	3-29	5	(1)	11.2074.0.000	3-53	20	(1)
11.1040.0.000	3-11	12	1	11.1169.0.000	3-29	3	(1)	11.2086.0.000	3-53	19	(1)
11.1041.0.000	3-11	1	1	11.1171.0.000	3-29	20	2	11.2087.0.000	3-53	30	(2)
11.1043.0.000	3-11	7	1	11.1175.0.000	3-13	22	1	11.2088.0.000	3-53	22	(1)
11.1044.0.000	3-13	24	1	11.1177.0.000	3-13	2	1	11.2089.0.000	3-53	26	(1)
11.1047.0.000	3-7	1	1	11.1178.0.000	3-13	4	1	11.2090.0.000	3-47	13	1
11.1051.0.000	3-15	2	(1)	11.1184.0.000	3-29	10	(1)	11.2251.0.000	3-45	16	1
11.1051.0.050	3-15	1	1	11.1188.0.000	3-3	5	1	11.2254.0.000	3-45	23	2
11.1052.0.000	3-15	3	(1)	11.1195.0.000	3-3	18	1	11.2255.0.000	3-45	2	1
11.1054.0.000	3-15	7	1	11.1198.0.000	3-35	2	1	11.2256.0.000	3-45	3	1
11.1058.0.050	3-17	10	1	11.2001.0.000	3-45	1	1	11.2262.0.000	3-45	15	1
11.1059.0.000	3-17	9	2	11.2002.0.000	3-55	7	2	11.2263.0.000	3-45	5	1
11.1060.0.050	3-17	12	1	11.2003.0.000	3-55	9	1	11.2263.0.901	3-45	6	(1)
11.1061.0.000	3-17	3	(1)	11.2004.0.000	3-55	8	1	11.3001.0.000	3-3	1	1
11.1063.0.000	3-17	14	1	11.2005.0.000	3-55	5	2	11.3001.0.902	3-3	2	(3)
11.1064.0.000	3-17	16	1	11.2006.0.000	3-51	9	1	11.3002.0.000	3-3	28	1
11.1066.0.000	3-17	15	1	11.2008.0.000	3-51	3	2	11.3004.0.000	3-17	2	(1)
11.1067.0.000	3-17	13	1	11.2009.0.000	3-51	1	2	11.3004.0.050	3-17	1	1
11.1068.0.000	3-41	13	(1)	11.2012.0.000	3-47	6	1	11.3005.0.000	3-51	7	2
11.1068.0.050	3-41	12	1	11.2013.0.000	3-47	10	1	11.3006.0.000	3-17	6	(1)
11.1071.0.000	3-41	30	(1)	11.2016.0.000	3-45	9	1	11.3006.0.050	3-17	5	1
11.1072.0.000	3-41	20	(1)	11.2018.0.000	3-45	7	1	11.3009.0.000	3-39	1	1
11.1074.0.000	3-41	21	1	11.2021.0.000	3-53	36	1	11.3015.0.000	3-39	2	1
11.1075.0.000	3-39	4	1	11.2023.0.000	3-53	14	(1)	11.3016.0.000	3-39	9	1
11.1082.0.000	3-3	6	1	11.2024.0.000	3-53	27	(2)	11.3017.0.000	3-39	15	1

INDEX

PART NUMBER	PAGE	DET	QTY	PART NUMBER	PAGE	DET	QTY	PART NUMBER	PAGE	DET	QTY
11.3017.0.000	3-43	3	1	11.3259.0.001	3-37	12	1	12.1010.0.312	3-35	20	1
11.3019.0.000	3-43	7	1	11.3259.0.002	3-37	13	1	12.1010.0.314	3-3	16	1
11.3021.0.001	3-43	13	1	11.3300.0.000	3-43	10	1	12.1010.0.314	3-11	22	1
11.3021.0.002	3-43	11	1	11.3301.0.000	3-43	8	2	12.1010.0.320	3-3	8	2
11.3021.0.003	3-43	12	1	11.3302.0.000	3-43	9	1	12.1010.0.412	3-11	20	1
11.3022.0.050	3-49	12	1	11.3303.0.000	3-43	1	1	12.1010.0.516	3-27	06	1+(1)
11.3022.1.000	3-49	14	(1)	11.4001.0.050	3-21	1	1	12.1010.0.520	3-5	19	1
11.3023.1.000	3-49	13	(1)	11.4002.0.000	3-21	11	(1)	12.1010.0.630	3-25	28	1
11.3024.0.000	3-49	24	(1)	11.4002.0.050	3-21	8	1	12.1011.0.425	3-37	16	1
11.3025.0.000	3-49	15	(1)	11.4004.0.000	3-21	7	1	12.1014.0.007	3-31	5	(1)
11.3027.0.000	3-27	08	1	11.4005.0.000	3-21	6	1	12.1014.0.308	3-53	29	(2)
11.3029.0.000	3-49	2	(1)	11.4006.0.000	3-21	5	1	12.1016.0.002	3-3	33	2
11.3029.0.050	3-49	1	1	11.4007.0.000	3-21	2	1	12.1016.0.002	3-11	27	1
11.3032.0.000	3-49	22	(1)	11.4008.0.000	3-21	4	1	12.1016.0.002	3-57	36	2
11.3034.0.000	3-43	4	1	11.4009.0.000	3-21	3	1	12.1040.1.007	3-5	18	1
11.3035.0.000	3-27	11	2	11.4011.0.000	3-21	10	(1)	12.1045.0.004	3-29	13	(1)
11.3046.0.000	3-25	15	1	11.4020.0.000	3-21	31	1	12.1045.1.001	3-5	24	1
11.3047.0.000	3-25	1	1	11.4201.0.000	3-21	9	(1)	12.1045.1.010	3-25	35	1
11.3050.0.000	3-25	2	1	11.4202.0.000	3-35	3	1	12.2010..0009	3-63	8	(2)
11.3054.0.000	3-25	36	1	11.5001.1.000	3-57	1	1	12.2010.0.011	3-11	21	1
11.3061.0.000	3-27	5	(2)	11.5003.0.000	3-57	5	1	12.2010.1.001	3-9	16	(1)
11.3062.0.000	3-27	03	(1)	11.5004.0.000	3-57	4	2	12.2090.0.003	3-25	23	(1)
11.3064.0.000	3-27	02	(1)	11.5005.0.000	3-57	10	1	12.2099.1.006	3-5	17	5
11.3064.0.050	3-27	01	1	11.5007.0.000	3-57	37	1	12.2099.1.006	3-25	31	1
11.3065.0.000	3-27	02	(1)	11.5008.0.000	3-3	27	1	12.4010.0.004	3-61	15	(6)
11.3065.0.050	3-27	01	1	11.5009.0.000	3-57	27	1	12.4021.0.312	3-19	12	1
11.3066.0.000	3-27	09	4	11.5011.0.000	3-57	43	1	12.4030.0.545	3-5	20	1
11.3067.0.000	3-41	3	(1)	11.5019.0.000	3-35	15	1	12.5050.1.018	3-63	23	1
11.3070.0.000	3-41	2	(1)	11.5021.0.000	3-57	2	1	12.5050.1.020	3-63	22	1
11.3070.0.050	3-41	1	1	11.5022.0.000	3-57	3	1	12.8000.0.107	3-57	40	1
11.3079.0.000	3-25	21	(1)	11.5031.0.000	3-57	22	1	12.8000.0.409	3-41	27	(1)
11.3080.0.000	3-25	27	(1)	11.5055.0.050	3-59	55	1	12.8000.0.416	3-57	39	1
11.3081.0.000	3-29	22	1	12.0008.4.206	3-61	25	1	12.8000.1.001	3-57	34	1
11.3082.0.000	3-25	22	(1)	12.0008.4.285	3-61	26	1	12.8000.1.027	3-3	32	1
11.3083.0.000	3-29	24	1	12.0008.6.001	3-65	10	1	13.2087.1.000	3-53	41	1
11.3085.0.000	3-35	10	1	12.0008.6.005	3-65	9	1	13.3083.0.000	3-3	10	1
11.3087.0.000	3-35	18	1	12.0008.6.102	3-65	14	1	14.1015.0.000	3-19	7	1
11.3088.0.000	3-35	22	1	12.0008.6.109	3-65	13	1	14.1022.3.000	3-9	19	(2)
11.3100.0.050	3-25	39	1	12.0008.6.215	3-65	12	1	14.1025.3.000	3-9	20	(2)
11.3101.0.000	3-25	19	(1)	12.0008.6.901	3-61	18	(1)	14.1025.3.000	3-41	25	2
11.3110.0.000	3-25	3	1	12.0008.6.915	3-61	19	(1)	14.1028.4.000	3-9	2	(1)
11.3123.0.000	3-25	11	1	12.0008.6.968	3-65	1	1	14.1029.0.000	3-19	11	1
11.3131.0.000	3-49	16	(1)	12.0008.6.978	3-65	11	1	14.1032.3.000	3-9	3	(1)
11.3205.0.000	3-35	13	1	12.0010.4.141	3-61	27	1	14.1070.4.000	3-9	12	(1)
11.3206.0.000	3-35	11	1	12.008.4.052	3-59	47	1	14.1099.0.000	3-31	10	(1)
11.3251.0.000	3-37	5	1	12.1010.0.206	3-11	13	1	14.1197.1.000	3-35	4	1
11.3252.0.000	3-37	6	2	12.1010.0.212	3-25	33	1	14.1250.0.000	3-9	28	2
11.3253.0.000	3-37	4	1	12.1010.0.308	3-35	14	1	14.2059.0.000	3-55	27	1
11.3254.0.000	3-37	3	1	12.1010.0.310	3-3	3	(3)	14.2060.0.000	3-55	28	1
11.3255.0.000	3-37	1	1	12.1010.0.310	3-29	27	2	14.3100.0.901	3-25	17	(1)

INDEX

PART NUMBER	PAGE	DET	QTY	PART NUMBER	PAGE	DET	QTY	PART NUMBER	PAGE	DET	QTY
14.4023.3.050	3-9	7	1	17.0014.1.068	3-29	18	1	17.0033.1.010	3-47	9	1
14.5034.0.000	3-31	13	(1)	17.0014.1.133	3-39	22	(2)	17.0033.1.011	3-17	21	1
15.4405.0.400	3-11	10	1	17.0014.1.205	3-31	2	(1)	17.0033.1.011	3-49	20	(1)
15.4530.0.200	3-21	41	1	17.0014.3.011	3-49	17	(1)	17.0033.1.061	3-5	8	1
15.4531.0.200	3-21	40	1	17.0014.4.001	3-31	21	1	17.0033.1.109	3-11	9	1
17.0002.7.589	3-27	10	1	17.0016.1.054	3-15	6	(1)	17.0033.1.153	3-39	17	1
17.0003.6.156	3-61	31	(1)	17.0016.1.093	3-21	46	1	17.0033.2.030	3-47	15	1
17.0004.3.485	3-57	12	1	17.0016.1.118	3-11	26	1	17.0033.2.133	3-57	6	1
17.0004.4.829	3-21	20	2	17.0016.1.141	3-47	12	1	17.0033.3.053	3-31	14	1
17.0004.5.386	3-25	5	1	17.0016.1.191	3-11	25	2	17.0033.3.131	3-17	7	(2)
17.0004.7.242	3-19	6	1	17.0017.1.016	3-21	26	1	17.0033.3.132	3-39	7	1
17.0004.7.253	3-5	16	1	17.0017.2.049	3-11	18	1	17.0033.3.133	3-53	15	(1)
17.0007.8.172	3-63	16	1	17.0019.0.228	3-21	18	2	17.0033.3.134	3-49	11	(1)
17.0011.1.148	3-47	22	1	17.0019.0.230	3-29	19	2	17.0033.5.052	3-53	32	1
17.0011.2.014	3-25	12	1	17.0019.0.232	3-57	42	2	17.0033.5.113	3-25	9	(1)
17.0011.2.063	3-25	30	2	17.0019.0.237	3-5	26	1	17.0034.0.400	3-63	3	(1)
17.0011.2.063	3-41	26	(1)	17.0019.0.398	3-23	51	2	17.0034.2.324	3-53	2	(1)
17.0011.3.022	3-31	7	(1)	17.0019.0.441	3-61	14	(8)	17.0041.1.094	3-21	16	4
17.0011.8.041	3-21	28	1	17.0019.0.610	3-25	14	1	17.0041.8.005	3-55	17	2
17.0012.0.120	3-9	10	(2)	17.0019.0.662	3-11	24	1	17.0041.8.008	3-29	9	(1)
17.0012.0.254	3-53	8	(2)	17.0019.1.062	3-9	26	(2)	17.0041.8.008	3-31	6	1
17.0012.0.303	3-55	23	2	17.0019.1.088	3-21	21	2	17.0041.8.067	3-51	11	1
17.0012.0.404	3-21	13	2	17.0019.2.021	3-27	14	2	17.0041.8.181	3-39	13	1
17.0012.0.571	3-41	9	(1)	17.0019.2.066	3-55	16	2	17.0041.8.181	3-49	28	(1)
17.0012.0.571	3-41	18	(1)	17.0019.5.040	3-55	15	2	17.0042.1.283	3-9	14	(1)
17.0012.0.688	3-35	6	1	17.0021.1.045	3-5	7	1	17.0043.6.018	3-39	11	1
17.0012.1.140	3-21	15	2	17.0021.1.050	3-53	18	(1)	17.0043.6.277	3-9	9	2
17.0012.1.142	3-21	19	2	17.0021.1.073	3-41	10	1	17.0044.2.232	3-5	12	1
17.0012.1.148	3-49	9	(1)	17.0021.1.201	3-63	4	(1)	17.0044.2.234	3-5	14	1
17.0012.1.169	3-11	3	(1)	17.0021.1.202	3-63	6	(1)	17.0044.2.430	3-5	9	1
17.0012.1.172	3-5	10	1	17.0026.0.213	3-25	32	1	17.0044.5.114	3-25	7	(1)
17.0012.2.400	3-21	38	1	17.0026.0.221	3-5	15	1	17.0045.1.099	3-11	8	1
17.0012.4.011	3-31	17	1	17.0026.1.082	3-41	33	(1)	17.0045.9.018	3-5	13	1
17.0012.4.042	3-35	8	1	17.0026.2.077	3-9	24	(1)	17.0051.0.401	3-63	5	(1)
17.0012.4.106	3-55	29	2	17.0026.2.078	3-21	42	1	17.0051.0.403	3-63	12	(1)
17.0013.1.045	3-51	18	4	17.0026.3.014	3-57	35	1	17.0052.0.315	3-25	6	(1)
17.0013.1.047	3-55	18	2	17.0026.3.126	3-31	29	1	17.0055.1.158	3-21	44	1
17.0013.1.171	3-57	16	1	17.0026.4.035	3-21	43	1	17.0055.3.025	3-39	3	1
17.0013.1.177	3-13	10	1	17.0026.4.036	3-31	28	1	17.0055.4.402	3-63	7	(1)
17.0013.1.417	3-31	20	1	17.0027.1.223	3-65	3	1	17.0055.4.404	3-63	17	1
17.0013.1.418	3-31	22	1	17.0027.1.419	3-9	30	1	17.0061.5.027	3-53	33	1
17.0013.1.419	3-31	16	1	17.0027.1.799	3-49	10	(1)	17.0062.5.015	3-47	14	1
17.0013.1.420	3-9	35	(1)	17.0027.4.045	3-21	50	1	17.0062.5.020	3-33	2	1
17.0013.2.086	3-15	8	1	17.0027.4.084	3-9	17	(1)	17.0062.5.144	3-49	7	(1)
17.0013.2.090	3-43	6	1	17.0027.4.085	3-37	2	1	17.0063.6.044	3-39	8	1
17.0013.3.402	3-57	41	2	17.0031.0.405	3-41	14	(1)	17.0063.6.068	3-5	11	1
17.0013.5.067	3-55	14	2	17.0031.0.406	3-21	47	1	17.0063.6.220	3-41	15	(1)
17.0013.5.069	3-51	20	2	17.0031.1.089	3-15	10	1	17.0063.6.308	3-39	6	1
17.0013.6.081	3-35	5	1	17.0031.4.030	3-53	39	1	17.0064.5.174	3-31	26	1
17.0014.1.015	3-29	23	2	17.0032.0.193	3-57	7	1	17.0064.6.117	3-21	23	1

INDEX

PART NUMBER	PAGE	DET	QTY	PART NUMBER	PAGE	DET	QTY	PART NUMBER	PAGE	DET	QTY
17.0064.6.416	3-41	7	(1)	19.0066.7.421	3-55	12	1				
17.0064.7.162	3-21	30	1	19.0067.2.415	3-11	19	1				
17.0067.2.411	3-5	6	1	19.0094.2.409	3-3	9	1				
17.0074.4.405	3-21	22	1	19.0094.5.409	3-3	30	1				
17.0081.5.047	3-45	26	1	19.0094.5.413	3-57	31	1				
17.0081.5.082	3-21	33	1	19.0095.1.405	3-57	38	1				
17.0082.2.054	3-51	19	2	19.0095.1.405	3-61	7	(4)				
17.0082.5.108	3-41	29	(1)	19.0095.1.408	3-57	13	1				
17.0082.5.884	3-55	24	1	22.0046.0.000	3-57	44	2				
17.0082.5.997	3-41	8	(1)	22.0104.0.000	3-19	2	1				
17.0082.5.997	3-41	17	(1)	22.0218.0.000	3-61	8	(1)				
17.0082.6.000	3-19	13	2	22.0229.0.000	3-19	3	1				
17.0082.8.017	3-9	34	(2)	24.0002.0.000	3-5	25	1				
17.0082.8.084	3-21	27	2								
17.0083.6.357	3-61	24	1								
17.0087.0.169	3-55	25	1								
17.0094.0.200	3-61	16	(4)								
17.0094.1.143	3-25	13	1								
17.0094.3.142	3-25	37	1								
17.0094.5.309	3-49	4	(1)								
17.0095.1.272	3-61	23	(4)								
17.0095.1.329	3-19	1	1								
17.0097.5.174	3-57	23	2								
18.0011.2.400	3-9	22	(2)								
18.0026.0.601	3-27	22	1								
18.0043.6.284	3-35	16	1								
18.0095.1.402	3-63	15	(4)								
19.0002.4.409	3-9	13	1								
19.0005.0.015	3-61	5	(1)								
19.0005.0.016	3-61	6	(1)								
19.0011.1.401	3-9	25	(1)								
19.0011.1.402	3-13	16	1								
19.0016.1.402	3-51	16	4								
19.0017.2.402	3-57	21	1								
19.0031.3.405	3-57	8	2								
19.0032.6.400	3-7	4	1								
19.0032.6.401	3-17	20	1								
19.0032.8.401	3-55	6	2								
19.0034.6.402	3-21	32	2								
19.0041.0.692	3-9	31	1								
19.0041.2.404	3-21	49	1								
19.0041.2.412	3-7	2	(1)								
19.0041.6.402	3-7	5	1								
19.0043.6.441	3-23	52	1								
19.0044.5.407	3-9	15	(1)								
19.0045.3.402	3-9	5	2								
19.0063.1.073	3-21	17	1								
19.0063.3.403	3-57	17	1								
19.0063.4.400	3-11	6	(1)								
19.0066.7.420	3-55	13	1								