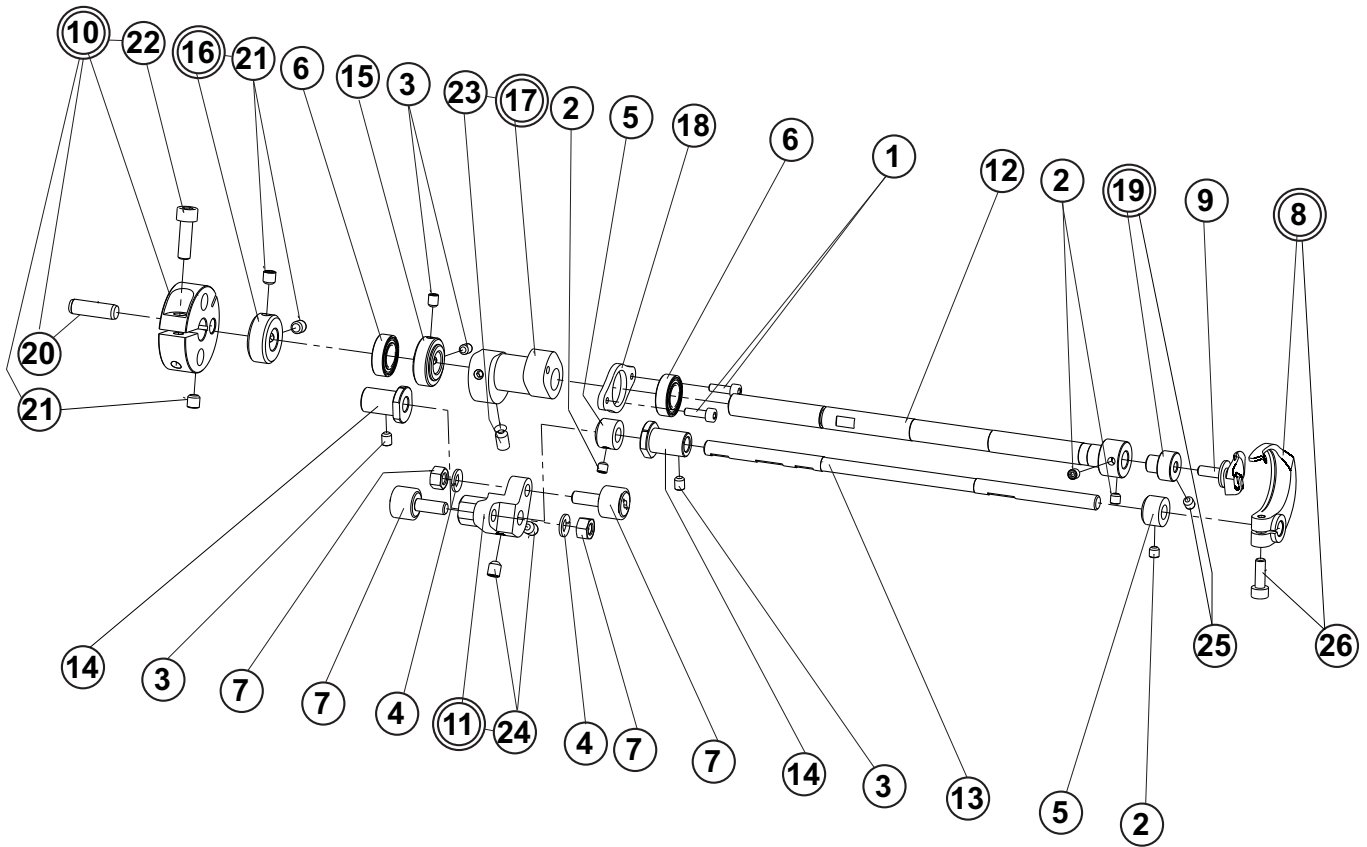

TABLE OF CONTENTS

LOOPER SHAFTS (73.9018.0.050).....	3-2
LOWER SHAFT (73.9015.0.050).....	3-4
DIFERENCIAL AXIS "Y" (73.9014.0.050).....	3-6
THREAD TRIM (73.9011.0.050).....	3-8
CLUTCH BOX (73.9001.0.050).....	3-10
SHAFT BITE (73.9024.0.050).....	3-12
UPPER SHAFT (73.9019.0.050).....	3-14
HAND WHEEL (73.9030.0.050).....	3-16
NEEDLE BAR (73.9002.0.050).....	3-18
"Z" AXIS (73.9013.0.050).....	3-20
"X" AXIS (73.9012.0.050).....	3-22
"Y" AXIS (73.9023.0.050).....	3-26
TABLE (73.9020.0.050).....	3-28
CARRIAGE (73.9025.0.050).....	3-30
COUNTER BUTTON (73.9026.0.050).....	3-32
DIFERENCIAL AXIS SCREW (73.9029.0.050).....	3-34
TONGUE (73.9017.1.050).....	3-36
FABRIC HOLDER (73.9027.0.050).....	3-38
PINCERS (73.9004.0.050).....	3-40
PINCERS - ARM LEFT (73.9005.0.050).....	3-42
PINCERS - ARM RIGHT (73.9006.0.050).....	3-44
THREAD DRAW-OFF (73.9003.0.050).....	3-46
DISPLAY PANEL (73.9010.0.050).....	3-48
STAND (04.9073.0.00).....	3-50
PEDAL (73.9008.0.050).....	3-52
VALVE BLOCK (73.7002.1.050).....	3-54
ARM AND BASE (73.9009.0.050).....	3-56
THREAD PICK-UP (73.9007.0.050).....	3-58
NEEDLE COVER (73.9022.0.050).....	3-60
FRONT COVER (73.9021.0.050).....	3-62
NECK WRAPPING (73.9028.0.050).....	3-64
BUTTON FEEDER (73.9016.0.050).....	3-66
BUTTON HOLDER 4-HOLES (73.9903.0.055).....	3-68
BUTTON HOLDER 2-HOLES (73.9903.0.056).....	3-70
SHANK BUTTON HOLDER (73.9903.0.054).....	3-72
LUBRICATING (73.9031.0.050).....	3-74
ELECTROBOX.....	3-76
ACCESSORIES (03.5573.0.001).....	3-78
ACCESSORIES (03.5573.0.002).....	3-80
HAND BUTTON FEEDING ASSY. (03.5573.0.003).....	3-82
EXTENDED TONGUE ASSY. (03.5573.0.004).....	3-84

LOOPER SHAFTS



LOOPER SHAFTS

DET	PART NUMBER	DESCRIPTION	QTY.
01	08.6002.3.010	SCREW M3-10	2
02	08.6410.4.004	SCREW M4-4	2
03	08.6410.4.005	SCREW M4-5	2
04	08.6802.5.000	SPRING WASHER M5	2
05	12.1050.0.002	CLAMP COLLAR 6	2
06	12.2010.0.038	BEARING	2
07	12.2099.2.001	CAM FOLLOWER	2
08	73.0050.0.600	SECONDARY LOOPER	1
09	73.0116.0.000	LOOPER	1
10	73.0123.0.050	ECCENTRIC ASSY.	1
11	73.0126.0.600	LEVER	1
12	73.0128.0.300	SHAFT	1
13	73.0130.0.300	SHAFT	1
14	73.0172.0.400	BUSHING	2
15	73.0173.0.400	COLLAR 9	1
16	73.0174.0.400	COLLAR 9	1
17	73.0175.0.400	CAM (M3)	1
18	73.0180.0.800	STOP	1
19	73.0181.0.400	COLLAR	1
20	12.1010.2.013	PIN	(1)
21	08.6410.5.005	SCREW M5-5	(2)+(1)
22	08.6002.5.016	SCREW M5-16	(1)
23	08.6400.5.008	SCREW M5-8	(2)
24	08.6400.5.006	SCREW M5-6	(2)
25	08.6400.4.005	SCREW M5-5	(1)
26	08.6002.4.012	SCREW M5-12	(1)

LOWER SHAFT

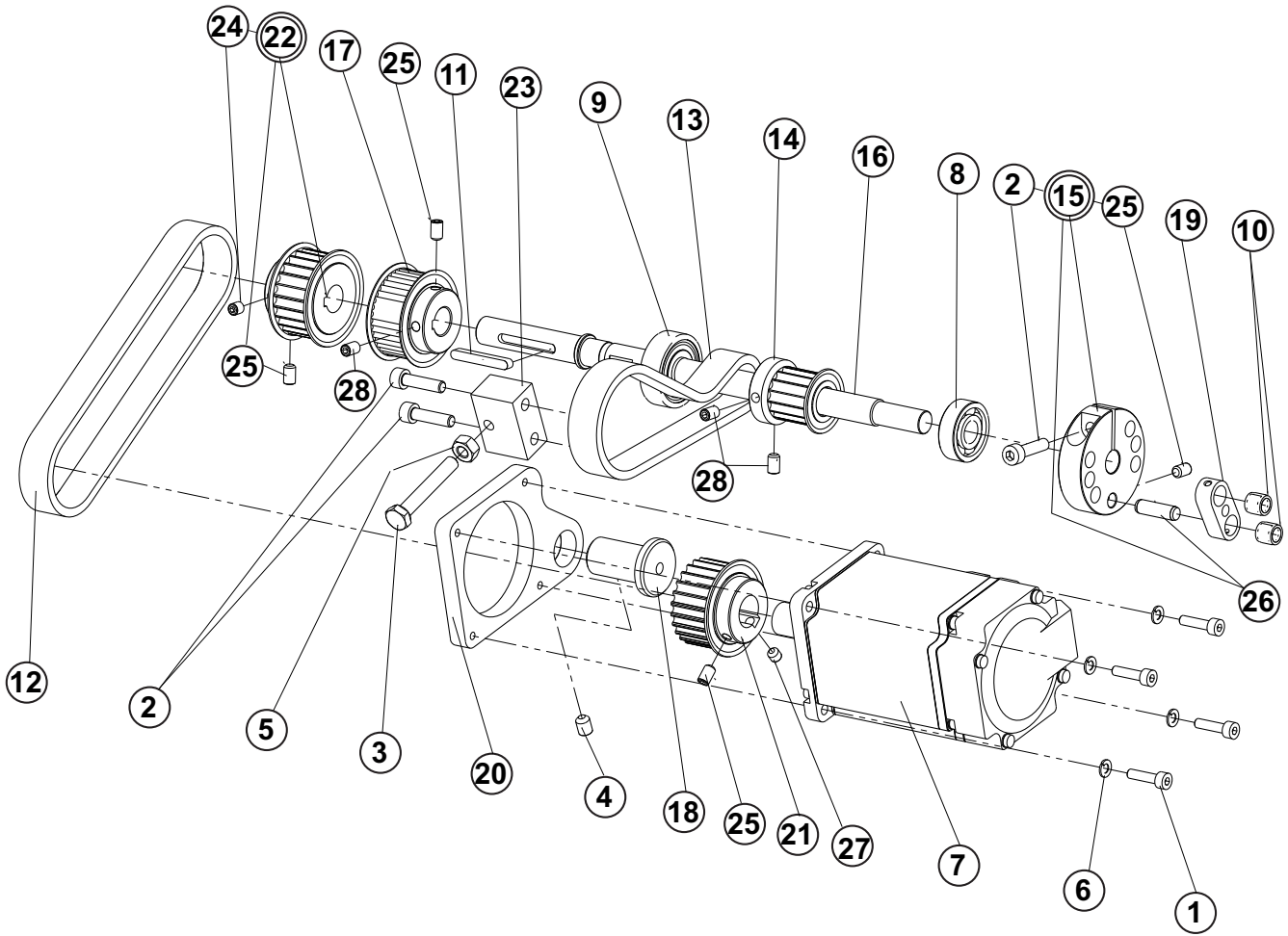

LOWER SHAFT

DET	PART NUMBER	DESCRIPTION	QTY.
01	08.6002.4.016	SCREW M4-16	4
02	08.6002.5.020	SCREW M5-20	2+(1)
03	08.6312.6.040	SCREW M6-40	1
04	08.6400.6.008	SCREW M6-8	1
05	08.6702.6.000	NUT M6	1
06	08.6802.4.000	SPRING WASHER M4	4
07	12.0010.4.177	SERVOMOTOR OMRON	1
08	12.2010.0.004	BEARING	1
09	12.2010.0.010	BEARING	1
10	12.2050.0.013	BEARING	2
11	12.4030.0.430	KEY	1
12	12.5050.2.035	BELT	1
13	12.5050.2.037	BELT	1
14	73.0120.0.500	PULLEY	1
15	73.0122.0.050	ECCENTRIC ASSY.	1
16	73.0124.0.300	SHAFT	1
17	73.0125.0.500	PULLEY	1
18	73.0127.0.300	STUD	1
19	73.0129.0.600	PISTON-ROD	1
20	73.0182.0.800	HOLDER	1
21	73.0183.0.500	PULLEY	1
22	73.0184.0.500	PULLEY	1
23	73.0185.0.600	STOP	1
24	08.6400.5.006	SCREW M5-6	(1)
25	08.6410.5.008	SCREW M5-8	1+(1)+(1)+(1)
26	12.1010.2.013	PIN	(1)
27	08.6400.5.005	SCREW M5-5	(1)
28	08.6400.5.008	SCREW M5-8	3

DIFERENCIAL AXIS "Y"

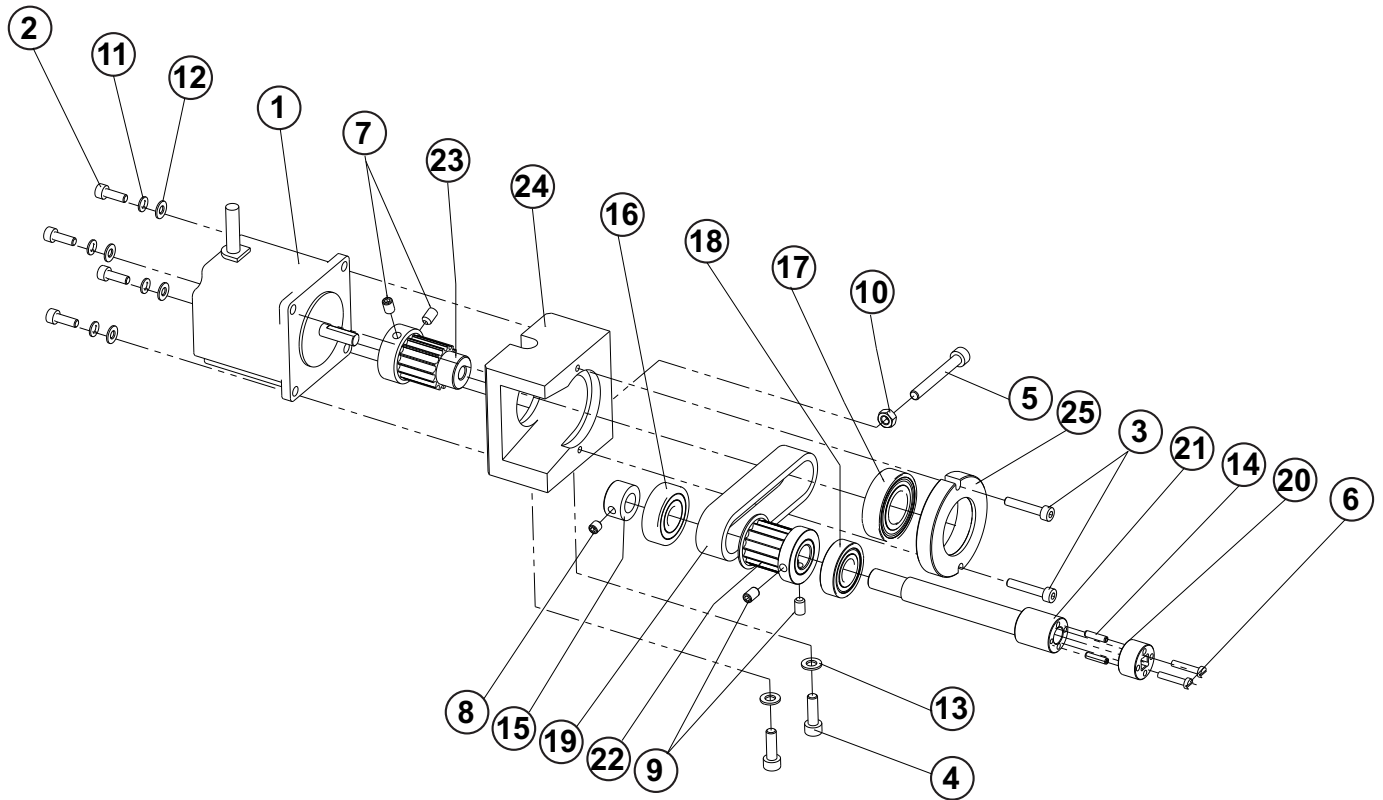

DIFERENCIAL AXIS "Y"

DET	PART NUMBER	DESCRIPTION	QTY.
01	06.7300.0.024	STEPPER MOTOR	1
02	08.6002.4.012	SCREW M4-12	4
03	08.6002.4.022	SCREW M4-22	2
04	08.6002.5.016	SCREW M5-16	2
05	08.6002.5.040	SCREW M5-40	1
06	08.6012.3.016	SCREW M3-16	2
07	08.6400.5.008	SCREW M5-8	2
08	08.6410.5.005	SCREW M5-5	1
09	08.6410.5.008	SCREW M5-8	2
10	08.6702.5.000	NUT M5	1
11	08.6802.4.000	SPRING WASHER M4	4
12	08.6852.4.000	WASHER M4	4
13	08.6852.5.000	WASHER 5,3	2
14	12.1014.0.002	PIN 3x8	2
15	12.1050.0.005	CLAMP COLLAR 10	1
16	12.2010.0.000	BEARING	1
17	12.2010.0.007	BEARING	1
18	12.2010.0.011	BEARING	1
19	12.5050.2.036	BELT	1
20	73.0118.0.992	GUIDING CARRIER	1
21	73.0119.0.300	SHAFT	1
22	73.0120.0.500	PULLEY GT	1
23	73.0322.0.500	PULLEY GT	1
24	73.0323.0.600	MOTOR HOLDER	1
25	73.0324.0.400	FLANGE	1

THREAD TRIM

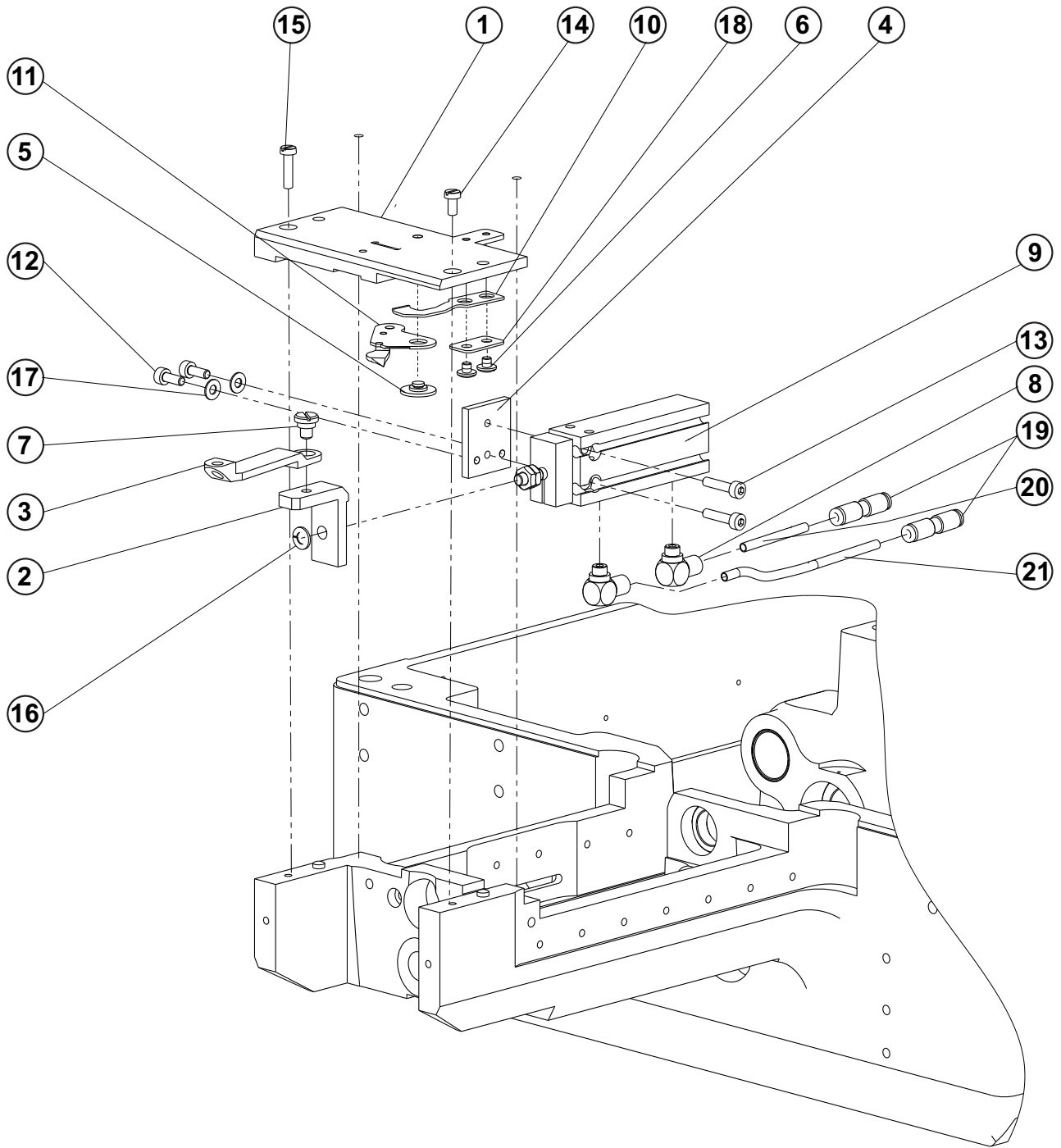

THREAD TRIM

DET	PART NUMBER	DESCRIPTION	QTY.
01	73.0033.0.600	THROAT PLATE	1
02	73.0090.0.600	HOLDER	1
03	73.0089.0.600	LINK	1
04	73.0088.0.600	PLATE	1
05	73.0253.0.100	SCREW	1
06	73.0274.0.100	SCREW	2
07	24.0061.0.000	THREAD TAKE-UP SHOULDER SCREW	1
08	12.0008.3.798	CONNECTOR	2
09	12.0010.3.134	CYLINDER	1
10	12.9900.9.007	KNIFE	1
11	12.9900.9.008	KNIFE	1
12	08.6002.3.008	SCREW M3-8	2
13	08.6002.3.014	SCREW M3-14	2
14	08.6012.3.006	SCREW M3-6	1
15	08.6012.3.012	SCREW M3-12	1
16	08.6802.4.000	SPRING WASHER M4	1
17	08.6852.3.000	WASHER M3	2
18	73.0301.0.800	WASHER	1
19	12.0010.3.132	CONNECTOR	2
20	12.0010.3.080	AIR TUBE J10A	1
21	12.0008.3.416	AIR TUBE J10B	1

CLUTCH BOX

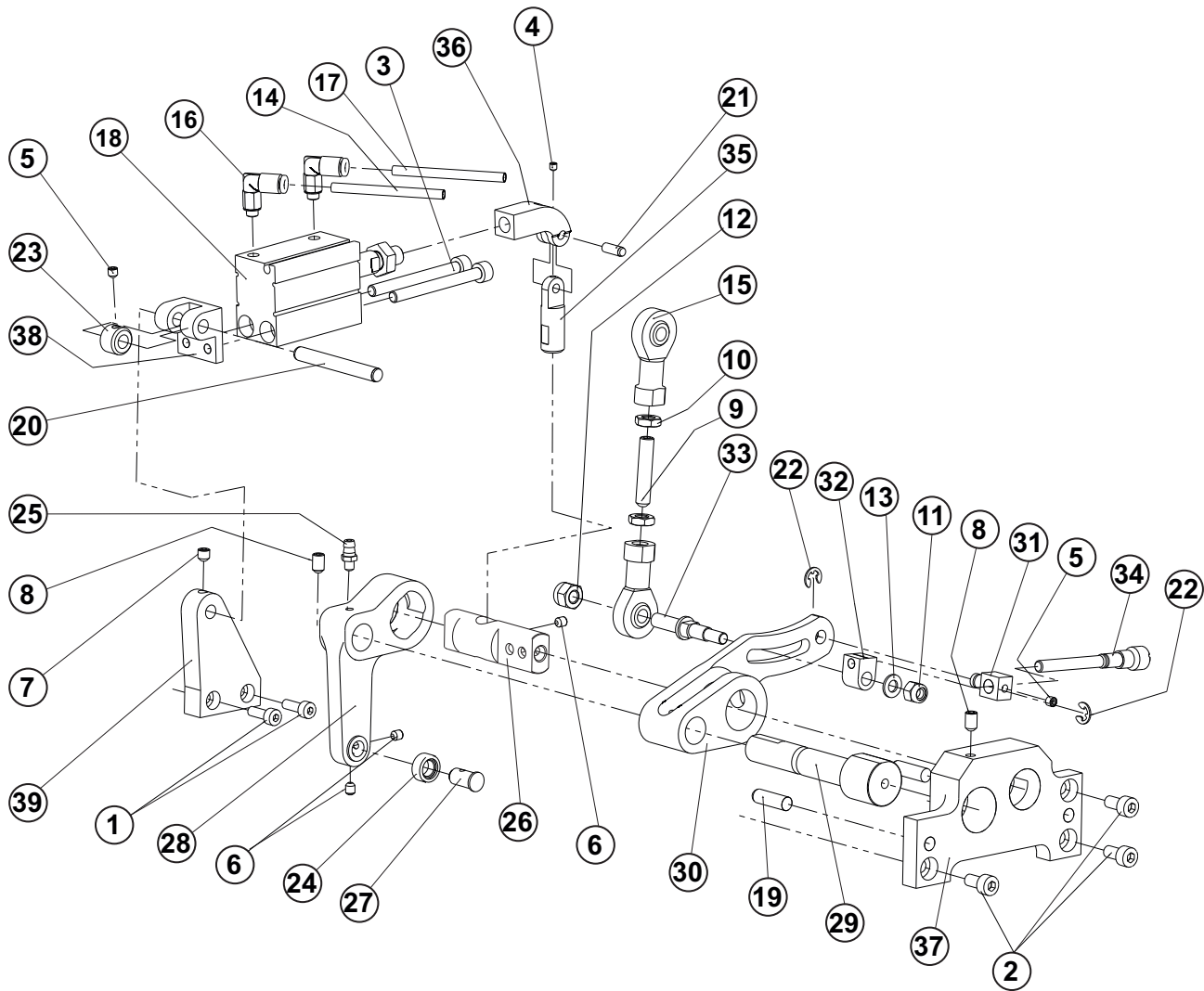

CLUTCH BOX

DET	PART NUMBER	DESCRIPTION	QTY.
01	08.6002.4.012	SCREW M4-12	2
02	08.6002.5.010	SCREW M5-10	3
03	08.6002.5.050	SCREW M5-50	2
04	08.6410.3.003	SCREW M3-3	1
05	08.6400.4.004	SCREW M4-4	2
06	08.6400.4.005	SCREW M4-5	3
07	08.6400.5.005	SCREW M5-5	1
08	08.6400.5.008	SCREW M5-8	2
09	08.6400.6.030	SCREW M6-30	1
10	08.6712.6.000	NUT M6	2
11	08.6732.5.000	NUT M5	1
12	08.6732.6.000	NUT M6	1
13	08.6852.5.000	WASHER	1
14	12.0008.3.416	AIR TUBE- J1B	1
15	12.0008.3.700	BEARING ROD END	2
16	12.0010.3.028	CONNECTOR	2
17	12.0010.3.080	AIR TUBE- J1A	1
18	12.0010.3.145	CYLINDER	1
19	12.1010.0.620	PIN 6-20	2
20	12.1010.2.024	PIN 6h6-50	1
21	12.1010.2.030	PIN 4h6-12	1
22	12.1045.0.004	RETAINING RING 4	2
23	12.1050.0.002	CLAMP COLLAR 6	1
24-1	15.4431.0.400	ROLL 0	1
24-2	15.4432.0.400	ROLL 05	
24-3	15.4433.0.400	ROLL 010	
24-4	15.4434.0.400	ROLL 015	
25	19.0044.1.623	NIPPLE, LUBRICATING M4	1
26	73.0002.1.300	RATCHET	1
27	73.0003.0.300	STUD	1
28	73.0004.0.600	LEVER	1
29	73.0005.0.300	SHAFT	1
30	73.0007.0.600	LEVER	1
31	73.0008.0.300	BLOCK	1
32	73.0009.0.600	BLOCK	1
33	73.0010.0.300	STUD	1
34	73.0011.0.100	SCREW M5	1
35	73.0012.0.300	STUD	1
36	73.0013.0.100	FORK	1
37	73.0014.0.600	PLATE	1
38	73.0021.0.600	HOLDER	1
39	73.0052.0.600	HOLDER	1

SHAFT BITE

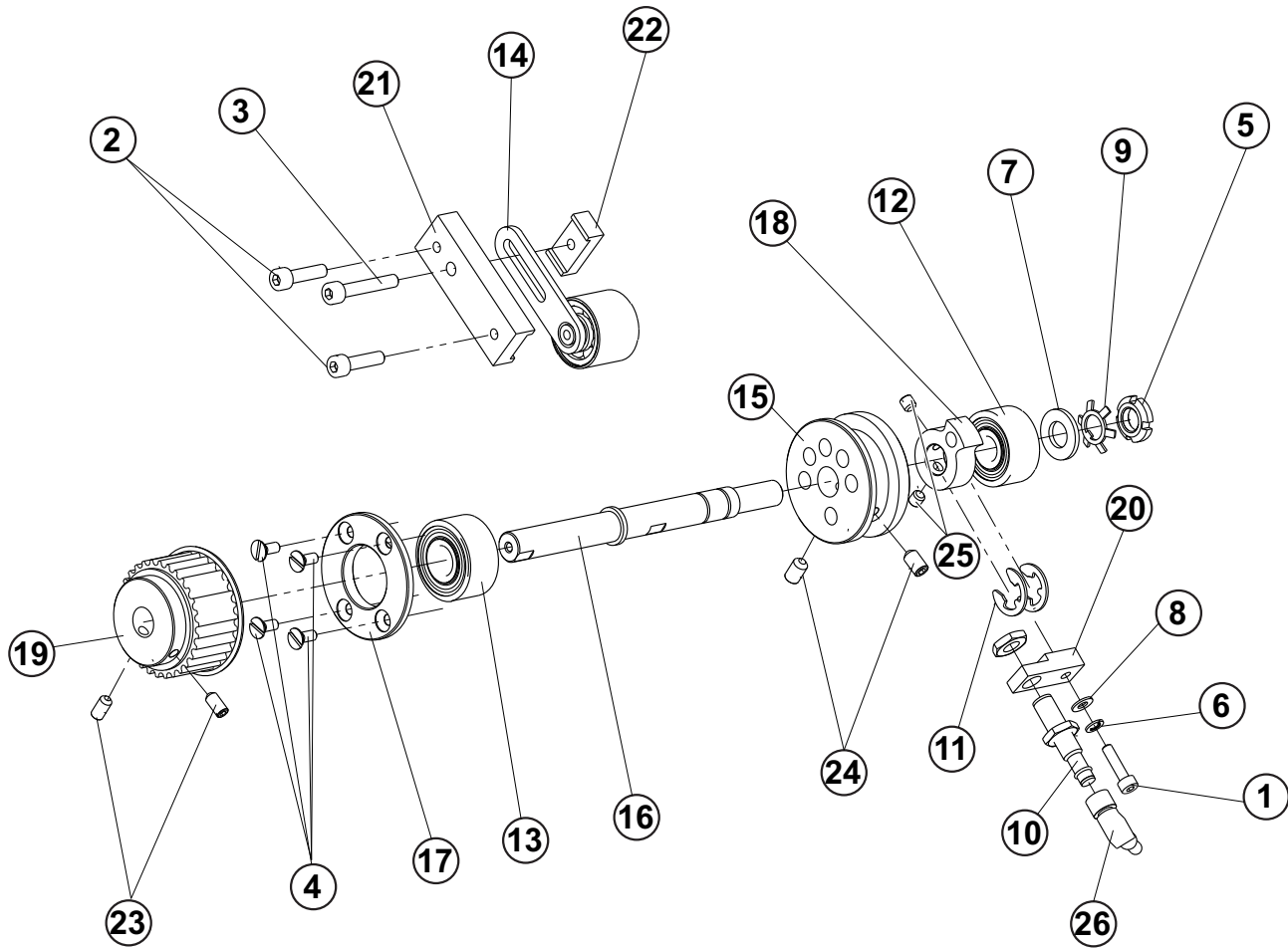

SHAFT BITE

DET	PART NUMBER	DESCRIPTION	QTY.
01	08.6002.4.016	SCREW M4-16	1
02	08.6002.5.020	SCREW M5-20	2
03	08.6002.5.030	SCREW M5-30	1
04	08.6110.4.010	SCREW M4-10	4
05	08.6792.0.300	NUT M10x0,75	1
06	08.6802.4.000	SPRING WASHER M4	1
07	08.6852.0.000	WASHER 10,5	1
08	08.6852.4.000	WASHER M4	1
09	08.6890.0.000	LOCK WASHER MB0	1
10	12.0010.4.093	SENSOR BQ 10	1
11	12.1045.0.009	E-CLIP 9	2
12	12.2010.0.040	BEARING	1
13	12.2010.0.041	BEARING	1
14	15.1128.0.050	TENSION PULLEY	1
15	73.0001.0.500	CAM	1
16	73.0006.0.300	SHAFT	1
17	73.0022.0.400	FLANGE	1
18	73.0023.0.600	SENSOR RING	1
19	73.0024.0.500	PULLEY GT	1
20	73.0025.0.600	HOLDER	1
21	73.0026.0.600	HOLDER TENSION PULLEY	1
22	73.0027.0.600	NUT M6	1
23	08.6400.5.010	SCREW M5-10	(2)
24	08.6400.6.010	SCREW M6-10	(2)
25	08.6410.5.005	SCREW M5-5	(2)
26	06.7300.0.050	CABLE BQ10	1

UPPER SHAFT

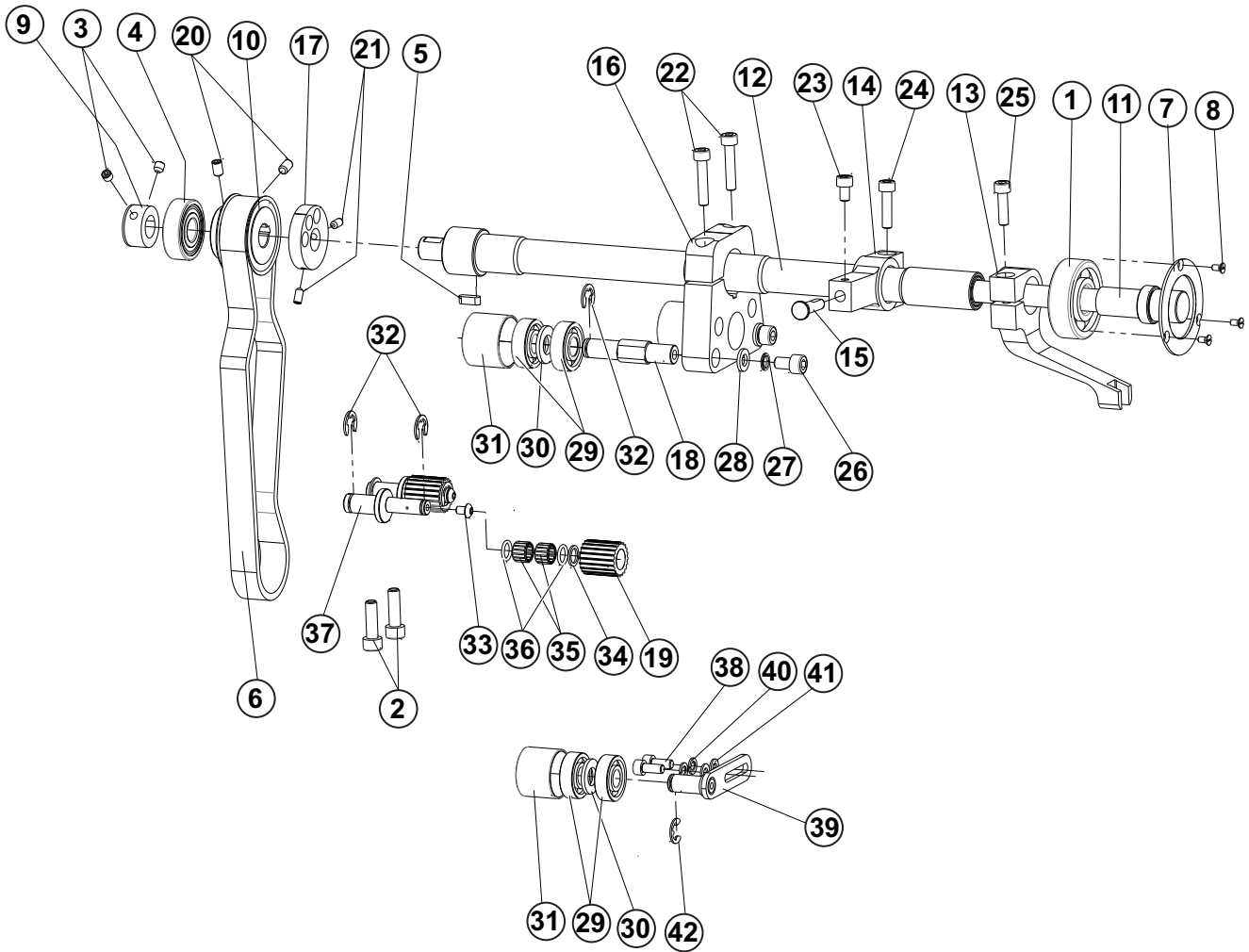

UPPER SHAFT

DET	PART NUMBER	DESCRIPTION	QTY.
01	01.7804.0.000	BEARING	1
02	08.6002.6.020	SCREW M6-20	2
03	08.6400.5.305	SCREW M5x0.5-5	(2)
04	12.2010.0.010	BEARING	1
05	12.4030.0.412	KEY	1
06	12.5050.2.038	BELT	1
07	15.1138.0.800	WASHER	1
08	15.1436.0.100	SCREW M3-6	3
09	17.0043.6.018	COLLAR RING	1
10	73.0125.0.500	PULLEY GT	1
11	73.0191.0.300	SHAFT	1
12	73.0192.0.300	SHAFT	1
13	73.0193.0.600	LEVER	1
14	73.0194.0.600	LEVER	1
15	73.0195.0.300	STUD	1
16	73.0196.0.600	LEVER	1
17	73.0197.0.400	ECCENTRIC RING	1
18	73.0200.0.300	STUD	2
19	73.0204.0.500	TIMING PULLEY	2
20	08.6400.5.008	SCREW M5-8	2
21	08.6402.4.008	SCREW M4-8	(2)
22	08.6002.5.025	SCREW M5-25	(2)
23	08.6002.5.008	SCREW M5-8	(1)
24	08.6002.5.020	SCREW M5-20	(1)
25	08.6002.5.018	SCREW M5-18	(1)
26	08.6002.6.010	SCREW M6-10	2
27	08.6802.6.000	SPRING WASHER M6	2
28	08.6850.6.000	WASHER M6	2
29	12.2010.0.004	BEARING	6
30	08.6850.0.000	WASHER	3
31	15.1106.0.400	ROLL	2
32	12.1045.0.007	RETAINER RING 7	6
33	08.6200.4.006	SCREW M4-6	2
34	73.0205.0.400	WASHER	2
35	12.2050.0.014	BEARING	4
36	12.0008.6.824	O-RING	4
37	73.0203.0.300	STUD	2
38	08.6002.5.012	SCREW M5-12	2
39	15.1128.0.000	BRACKET	1
40	08.6802.5.000	SPRING WASHER M5	2
41	08.6852.5.000	WASHER M5	2
42	17.0027.4.085	RETAINER RING 7	1

HAND WHEEL

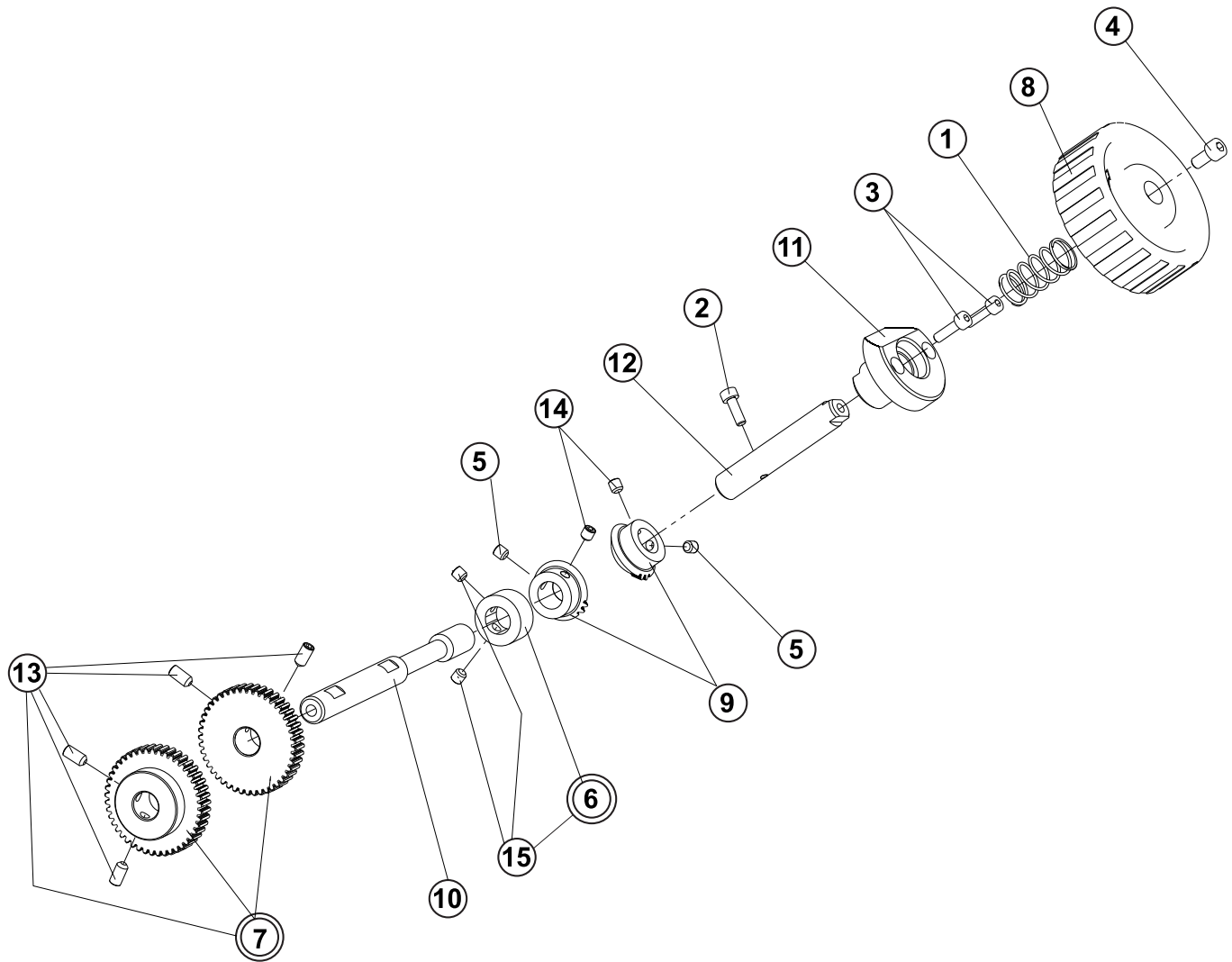

NEEDLE BAR

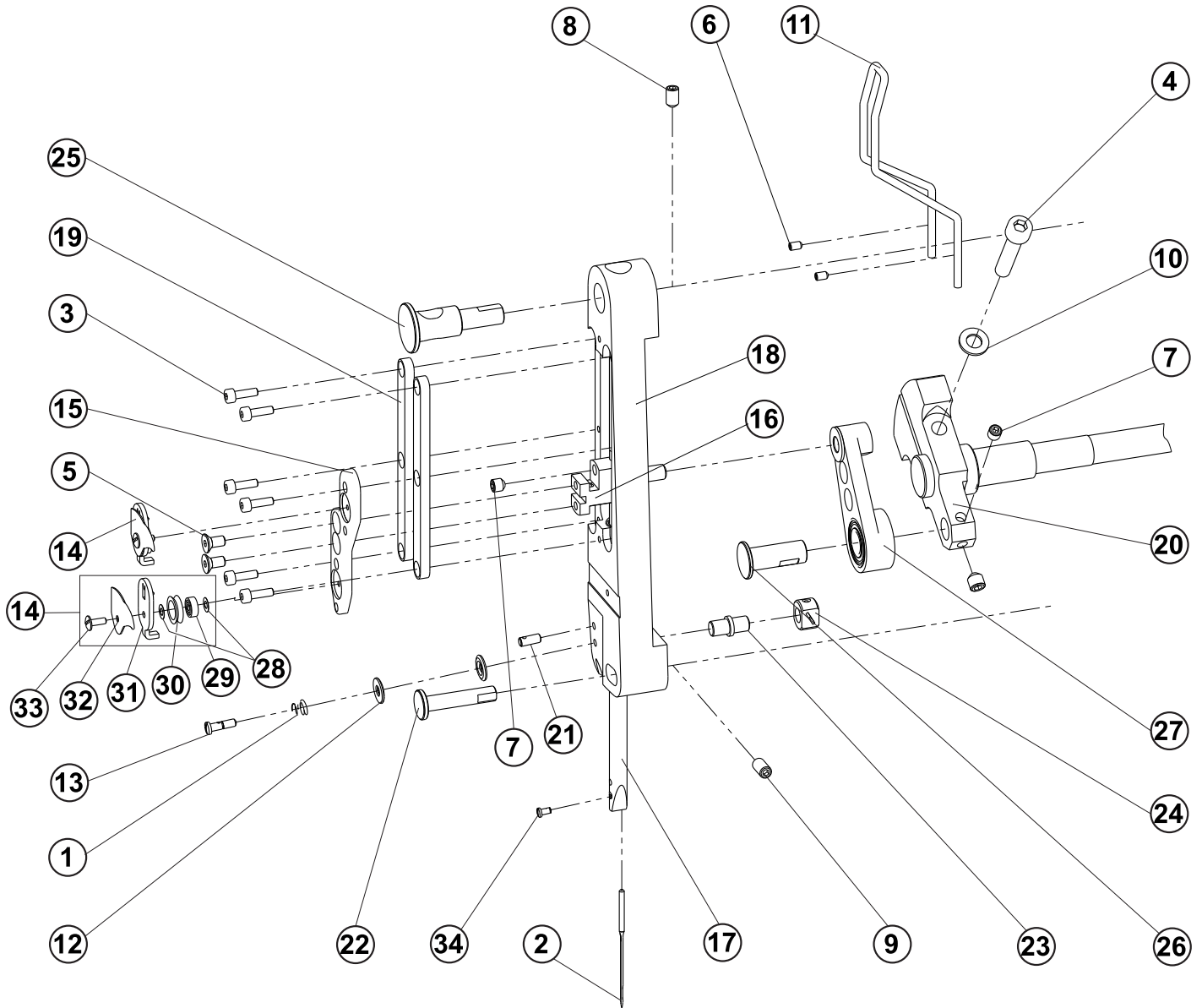

NEEDLE BAR

DET	PART NUMBER	DESCRIPTION	QTY.
01	01.5167.0.000	SPRING	1
02-1	02.0332.0.110	NEEDLE Nm 90/14	1
02-2	02.0332.0.111	NEEDLE Nm 100/16	
02-3	02.0332.0.112	NEEDLE Nm 110/18	
02-4	02.1332.0.111	NEEDLE LONG Nm 100/16	
03	08.6000.3.010	SCREW M3-10	6
04	08.6000.6.030	SCREW M6-30	1
05	08.6102.4.008	SCREW M4-8	2
06	08.6400.4.005	SCREW M4-5	2
07	08.6400.5.005	SCREW M5-5	3
08	08.6400.5.008	SCREW M5-8	1
09	08.6400.5.010	SCREW M5-10	1
10	08.6852.6.000	WASHER 6,4	1
11	17.0027.1.419	GUARD	1
12	17.0082.8.017	TENSION DISC	2
13	24.0100.0.000	SCREW M3.5x0.35-11	1
14	73.0015.0.050	TENSION ROLLER ASSY.	2
15	73.0034.0.600	HOLDER	1
16	73.0035.0.600	GUIDE	1
17	73.0036.0.300	NEEDLE BAR	1
18	73.0037.0.600	NEEDLE BAR HOLDER	1
19	73.0039.0.600	GUIDE	2
20	73.0040.0.600	EXCENTRIC	1
21	73.0041.0.100	THREAD GUIDE	1
22	73.0043.0.300	STUD	1
23	73.0044.0.300	STUD	1
24	73.0045.0.400	STONE	1
25	73.0046.0.300	STUD	1
26	73.0047.0.300	STUD	1
27	73.0048.0.600	LINK	1
28	08.6887.3.001	WASHER	(2)+(2)
29	12.2010.0.039	BEARING	(1)+(1)
30	73.0018.0.400	ROLLER	(1)+(1)
31	73.0016.0.800	HOLDER	(1)+(1)
32	73.0017.0.800	COVER	(1)+(1)
33	73.0199.0.100	SCREW M2,5-7	(1)+(1)
34	01.2193.0.000	SCREW # 4-60x0.156	(1)

"Z" AXIS

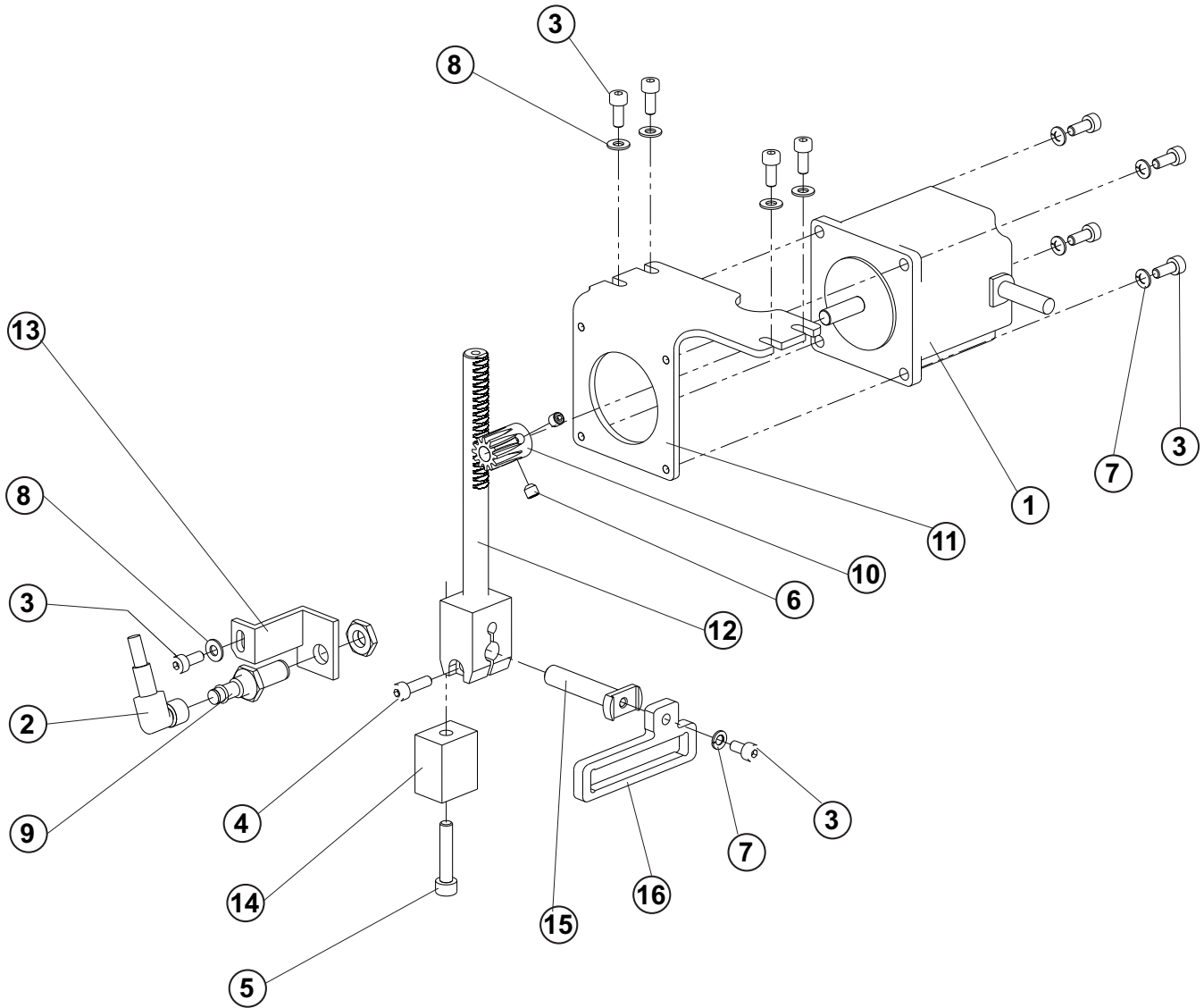

"X" AXIS

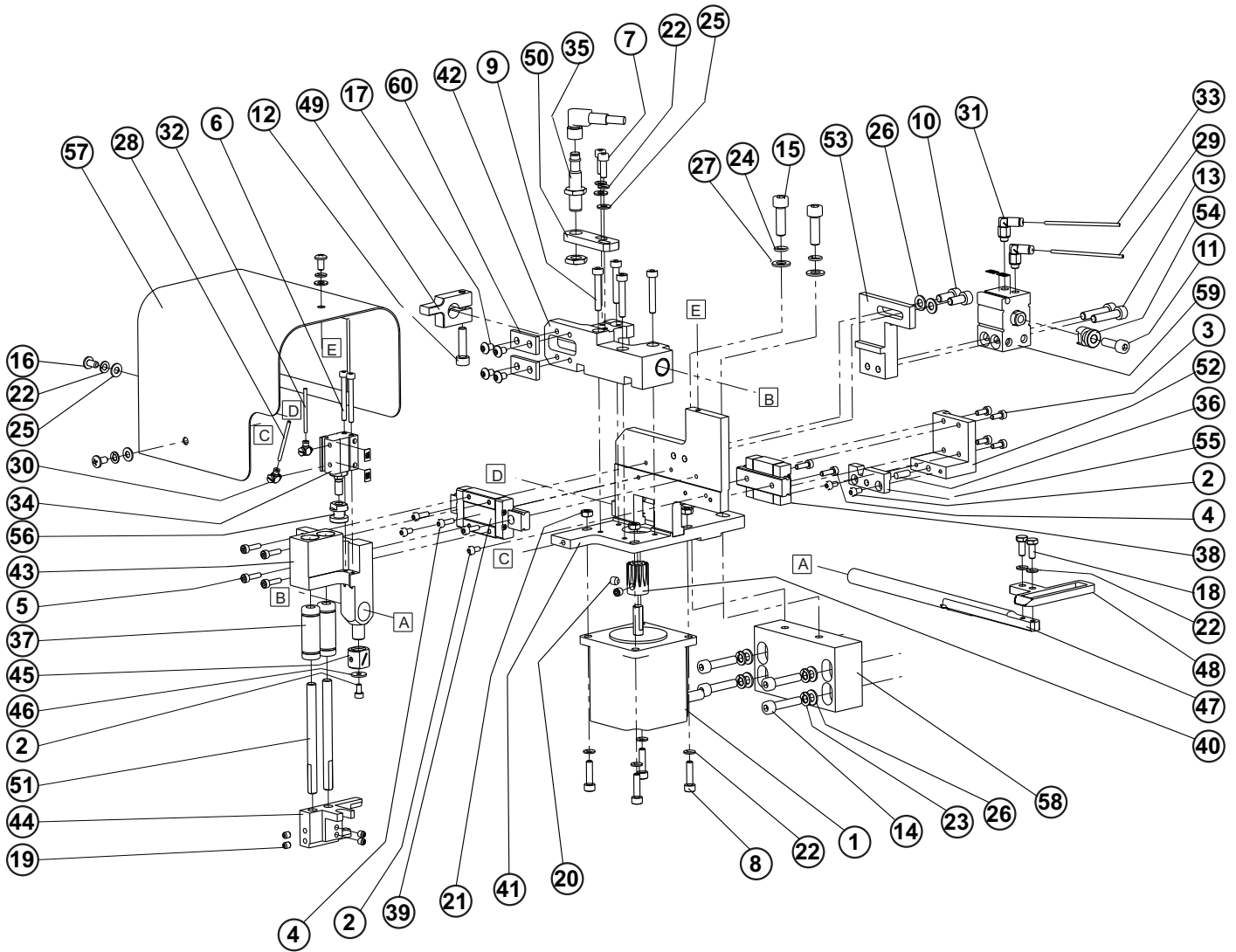

“X” AXIS

DET	PART NUMBER	DESCRIPTION	QTY.
01	06.7300.0.021	STEP. MOTOR SM1-XB ASSY.	1
02	08.6002.3.006	SCREW M3-6	5
03	08.6002.3.008	SCREW M3-8	4
04	08.6002.3.010	SCREW M3-10	5
05	08.6002.3.012	SCREW M3-12	4
06	08.6002.3.030	SCREW M3-30	2
07	08.6002.4.012	SCREW M4-12	2
08	08.6002.4.016	SCREW M4-16	4
09	08.6002.4.025	SCREW M4-25	4
10	08.6002.5.012	SCREW M5-12	2
11	08.6002.5.016	SCREW M5-16	1
12	08.6002.5.020	SCREW M5-20	1
13	08.6002.5.022	SCREW M5-22	2
14	08.6002.5.025	SCREW M5-25	4
15	08.6002.6.020	SCREW M6-20	2
16	08.6032.4.008	SCREW M4-8	3
17	08.6202.4.006	SCREW M4-6	4
18	08.6312.4.010	SCREW M4x10	2
19	08.6400.4.005	SCREW M4-5	4
20	08.6400.5.005	SCREW M5-5	2
21	08.6702.4.000	NUT M4	4
22	08.6802.4.000	SPRING WASHER M4	11
23	08.6802.5.000	SPRING WASHER M5	4
24	08.6802.6.000	SPRING WASHER M6	2
25	08.6852.4.000	WASHER M4	5
26	08.6852.5.000	WASHER 5,3	6
27	08.6852.6.000	WASHER 6,4	2
28	12.0008.3.749	AIR TUBING - J9B	1
29	12.0008.3.749	AIR TUBE- J20B	1
30	12.0008.3.826	CONNECTOR	2
31	12.0010.3.064	CONNECTOR	2
32	12.0010.3.103	AIR TUBING - J9A	1
33	12.0010.3.103	AIR TUBE- J20A	1
34	12.0010.3.193	CYLINDER	1
35	12.0010.4.093	SENSOR BQ	1
36	12.1010.0.412	PIN	1
37	12.2070.0.020	BEARING	2
38	12.2070.1.050	GUIDE	1
39	12.2070.1.055	GUIDE	1
40	24.4075.0.000	GEAR	1
41	73.0095.0.000	CONSOLE	1
42	73.0096.0.600	BLOCK	1
43	73.0097.0.600	BLOCK	1
44	73.0098.0.600	LATCH	1
45	73.0099.0.400	STONE	1
46	73.0100.0.800	WASHER	1

"X" AXIS

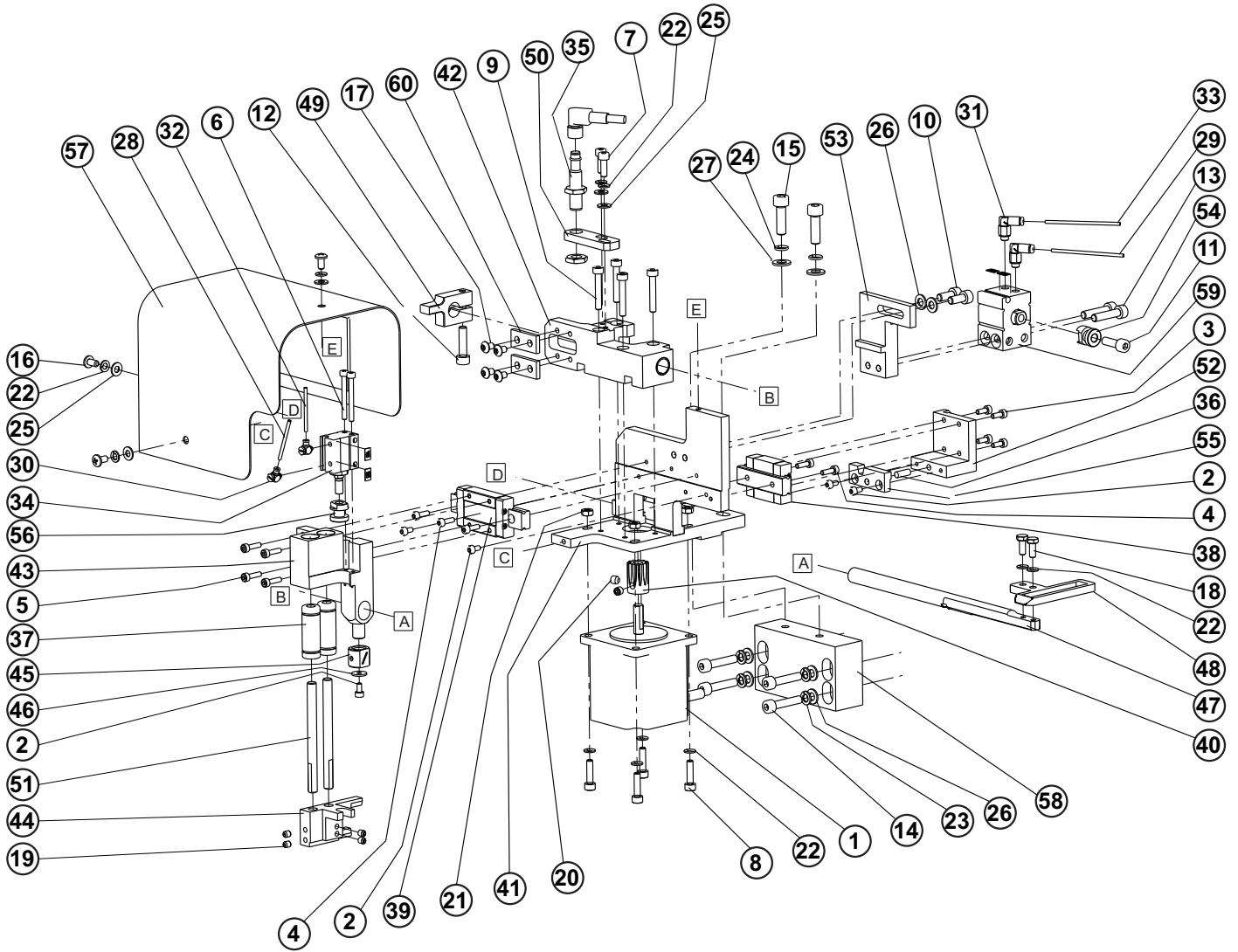

"Y" AXIS

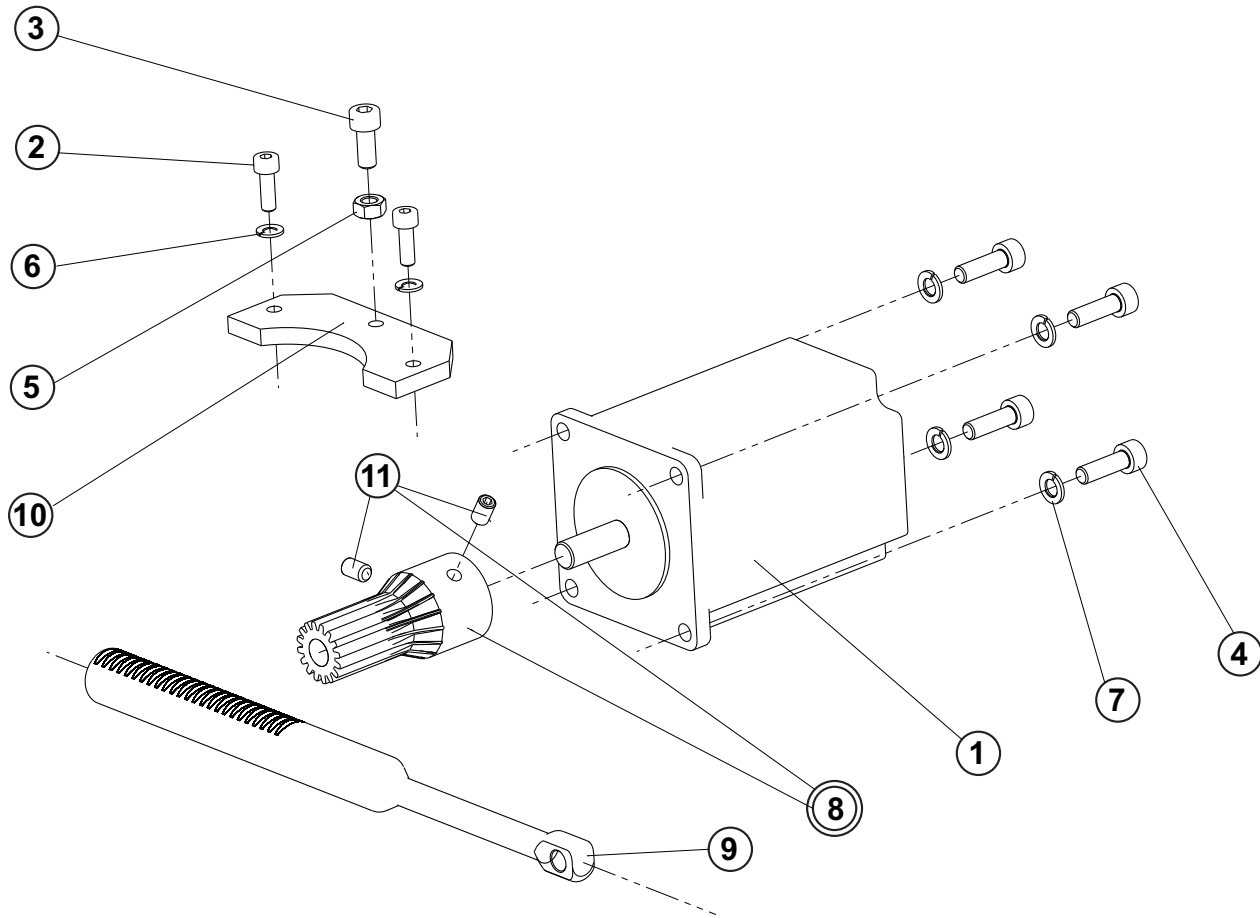

TABLE

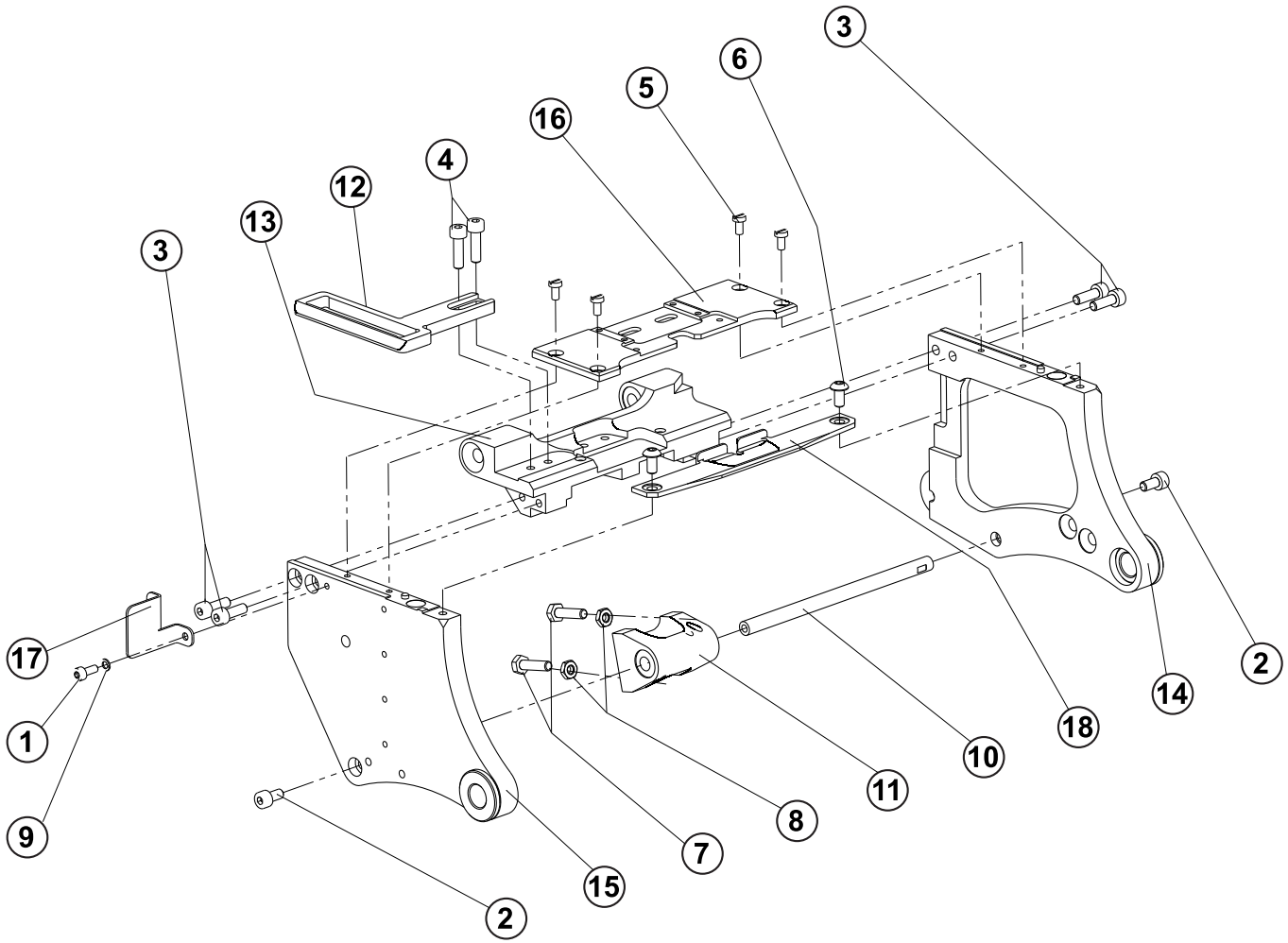

TABLE

DET	PART NUMBER	DESCRIPTION	QTY.
01	08.6002.3.008	SCREW M3-8	1
02	08.6002.4.008	SCREW M4-8	2
03	08.6002.4.012	SCREW M4-12	4
04	08.6002.4.014	SCREW M4-14	2
05	08.6012.3.006	SCREW M3-6	4
06	08.6202.4.008	SCREW M4-8	2
07	08.6310.4.016	SCREW M4x16	2
08	08.6712.4.000	NUT M4	2
09	08.6802.3.000	SPRING WASHER M3	1
10	73.0186.0.300	BAR	1
11	73.0188.0.050	BLOCK ASSY.	1
12	73.0223.0.800	GUIDE	1
13	73.0275.0.600	BLOCK	1
14	73.0276.0.600	ARM RIGHT	1
15	73.0277.0.600	ARM LEFT	1
16	73.0278.0.600	PLATE	1
17	73.0279.0.800	COVER	1
18-1	73.9905.0.601	PUCKER PIN	1
18-2	73.9905.0.602	PUCKER PIN - 4 HOLES	

CARRIAGE

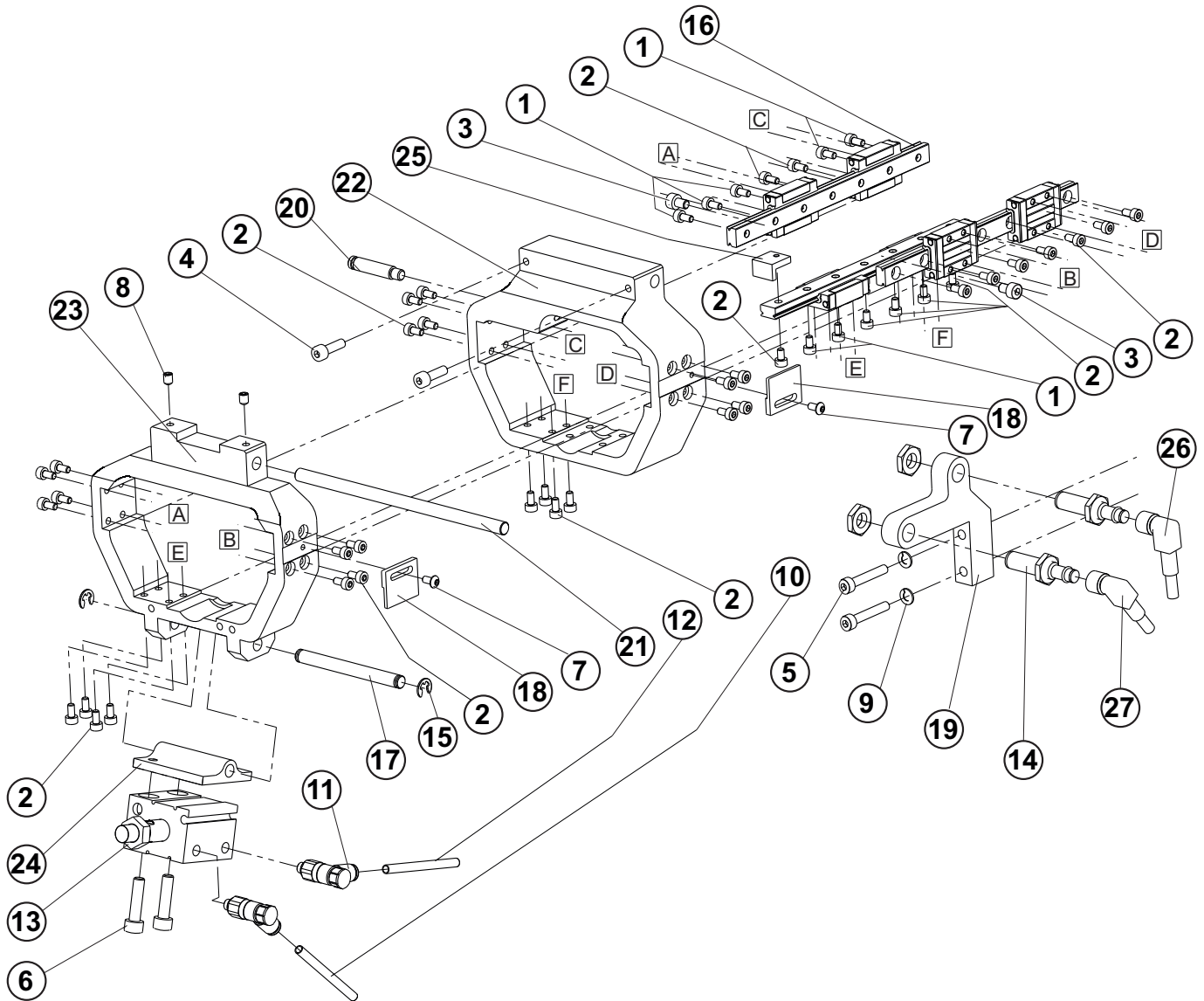

CARRIAGE

DET	PART NUMBER	DESCRIPTION	QTY.
01	08.6002.0.010	SCREW M3-10	14
02	08.6002.3.006	SCREW M3-6	31
03	08.6002.4.006	SCREW M4-6	2
04	08.6002.4.014	SCREW M4-14	2
05	08.6002.4.025	SCREW M4-25	2
06	08.6002.5.020	SCREW M5-20	2
07	08.6202.3.006	SCREW M3-6	2
08	08.6410.4.005	SCREW M4-5	2
09	08.6802.4.000	SPRING WASHER M4	2
10	12.0008.3.416	AIR TUBE J3B	1
11	12.0010.3.047	SPEED CONTR. AS	2
12	12.0010.3.080	AIR TUBE J3A	1
13	12.0010.3.158	CYLINDER	1
14	12.0010.4.093	SENSOR BQ2, BQ4	2
15	12.1045.0.004	RETAINING RING 4	2
16	12.2070.1.047	GUIDE	3
17	73.0187.0.300	STUD	1
18	73.0189.0.800	SENSOR PLATE	2
19	73.0190.0.800	HOLDER	1
20	73.0254.0.300	STUD	1
21	73.0255.0.300	BAR	1
22	73.0256.0.600	CARRIER BACK	1
23	73.0257.0.600	CARRIER FRONT	1
24	73.0258.0.600	HOLDER	1
25	73.0259.0.600	STOP	1
26	06.7300.0.042	CABLE	1
27	06.7300.0.044	CABLE	1

COUNTER BUTTON

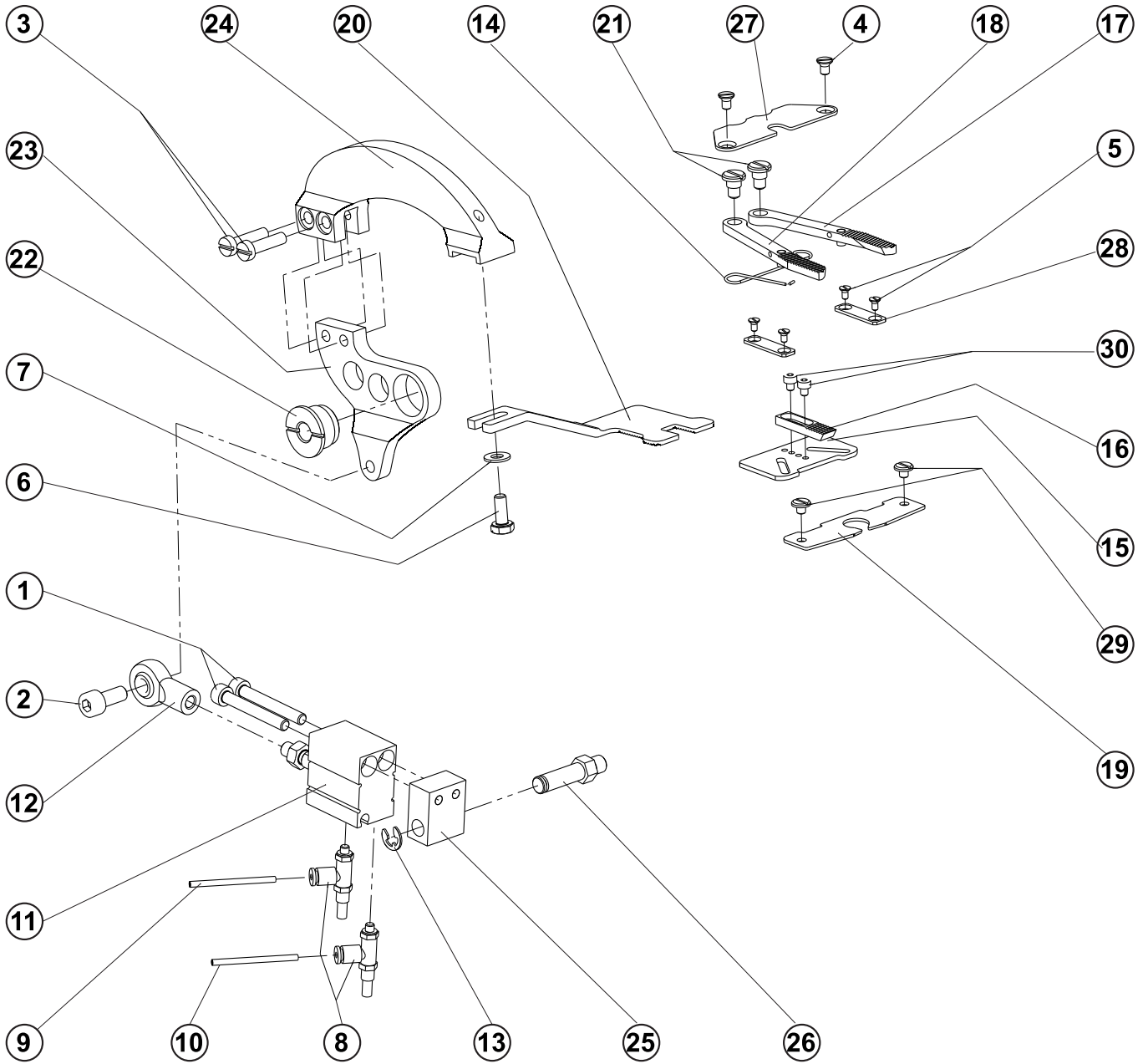

COUNTER BUTTON

DET	PART NUMBER	DESCRIPTION	QTY.
01	08.6002.4.030	SCREW M4-30	2
02	08.6002.5.012	SCREW M5-12	1
03	08.6012.4.016	SCREW M4-16	2
04	08.6112.3.005	SCREW M3x5	2
05	08.6117.2.004	SCREW M2-4	4
06	08.6312.4.010	SCREW M4x10	1
07	08.6852.4.000	WASHER M4	1
08	12.0008.3.810	SPEED CONTROLER	2
09	12.0010.3.103	AIR TUBING J6A	1
10	12.0010.3.103	AIR TUBING J14A	1
11	12.0010.3.190	CYLINDER	1
12	12.0010.6.210	ROD END	1
13	12.1045.0.004	RETAINING RING 4	1
14	73.0224.0.200	SPRING	1
15	73.0260.0.800	SLIDE	1
16	73.0261.0.600	MIDLLE CLAMP	1
17	73.0262.0.600	RIGHT CLAMP	1
18	73.0263.0.600	LEFT CLAMP	1
19	73.0264.0.800	PLATE	1
20	73.0265.0.800	CLAMP FOOT	1
21	73.0266.0.100	SCREW M4	2
22	73.0267.0.100	STUD M14x1	1
23	73.0268.0.600	LEVER	1
24	73.0269.0.600	CLAMP ARM	1
25	73.0270.0.600	HOLDER	1
26	73.0271.0.300	STUD	1
27	73.0272.0.800	COVER PLATE	1
28	73.0273.0.800	GUIDE	2
29	73.0274.0.100	SCREW M3-3	2
30	73.0297.0.100	SCREW M2,5-3	2

DIFERENCIAL AXIS SCREW

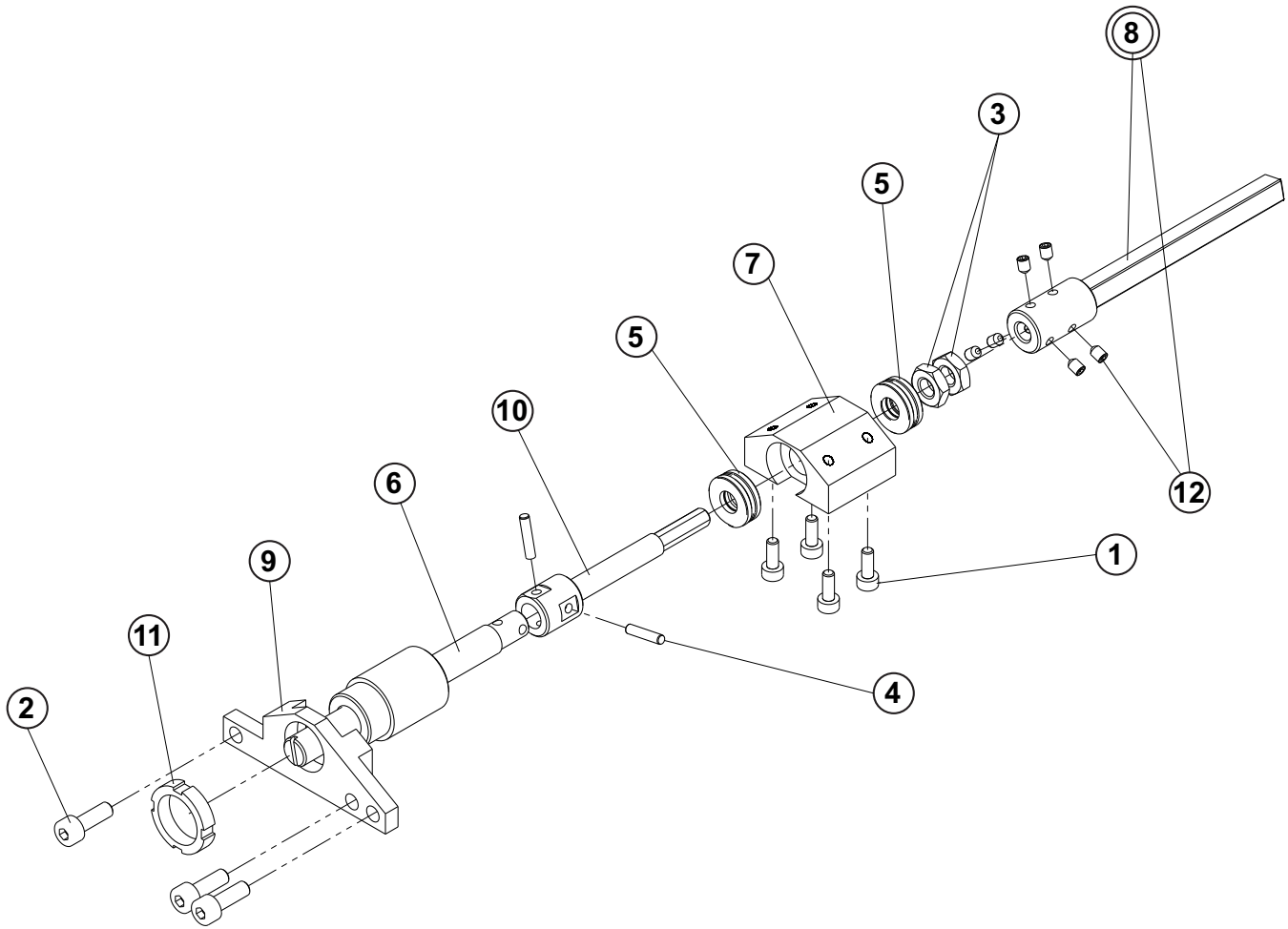

TONGUE

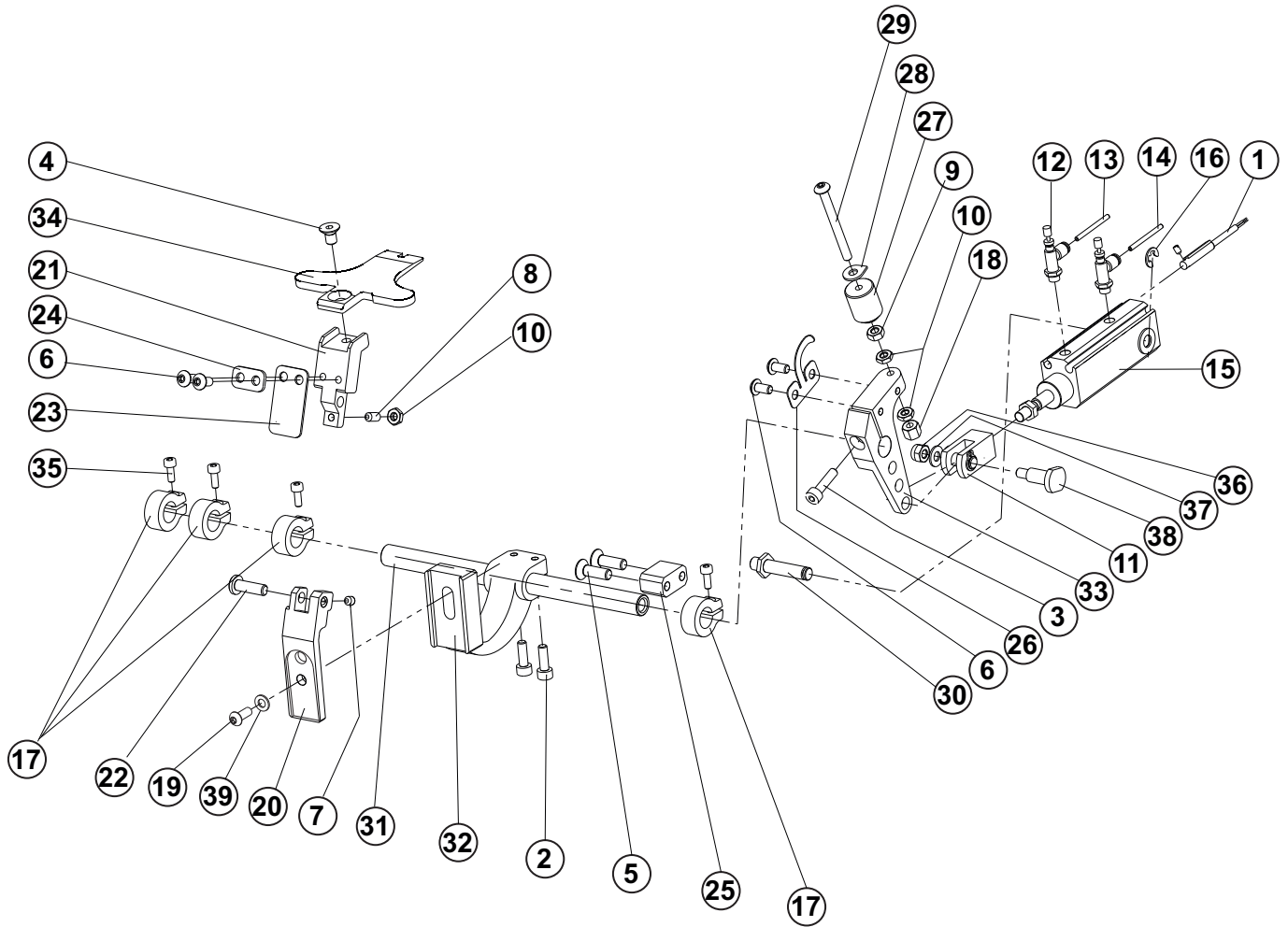

TONGUE

DET	PART NUMBER	DESCRIPTION	QTY.
01	06.7300.0.047	CABLE SENSOR	1
02	08.6002.4.012	SCREW M4-12	2
03	08.6002.4.016	SCREW M4-16	1
04	08.6102.5.008	SCREW M5-8	1
05	08.6102.5.016	SCREW M5-16	2
06	08.6202.4.008	SCREW M4-8	4
07	08.6402.4.005	SCREW M4-5	1
08	08.6402.4.008	SCREW M4-8	1
09	08.6700.4.000	NUT M4	1
10	08.6710.4.000	NUT M4	3
11	12.0008.3.739	KNUCKLE	1
12	12.0008.3.815	SPEED CONTR. AS	2
13	12.0010.3.103	AIR TUBING - J4A	1
14	12.0010.3.103	AIR TUBING - J5A	1
15	12.0010.3.123	CYLINDER	1
16	12.1045.0.004	RETAINING RING 4	1
17	73.0303.0.600	CLAMP COLLAR 10	4
18	19.0016.3.406	NUT M4-6,5	1
19	08.6202.6.016	SCREW M6-16	1
20	73.0337.0.600	ARM	1
21	73.0338.0.600	HOLDER	1
22	71.1664.1.087	STUD	1
23	71.1664.2.088	FLAT SPRING 1,5 mm	1
24	71.1664.1.093	WASHER	1
25	71.1665.1.017	ENDSTOP	1
26	71.1665.1.019	SPRING	1
27	71.1665.1.020	NUT M4	1
28	71.1665.1.021	ARROW	1
29	71.1665.1.022	SCREW M4x43	1
30	73.0176.0.300	STUD	1
31	73.0177.0.300	BAR	1
32	73.0336.0.600	LEVER	1
33	73.0179.0.600	LEVER	1
34-1	73.9902.0.801	TONGUE - STANDARD	1
34-2	73.9902.0.802	TONGUE - STANDARD - HOLES	
35	08.6002.3.008	SCREW M3-8	(4)
36	08.6732.4.000	NUT M4	1
37	08.6852.4.000	WASHER M4	1
38	73.0311.0.300	STUD	1
39	08.6852.6.000	WASHER M6	1

FABRIC HOLDER

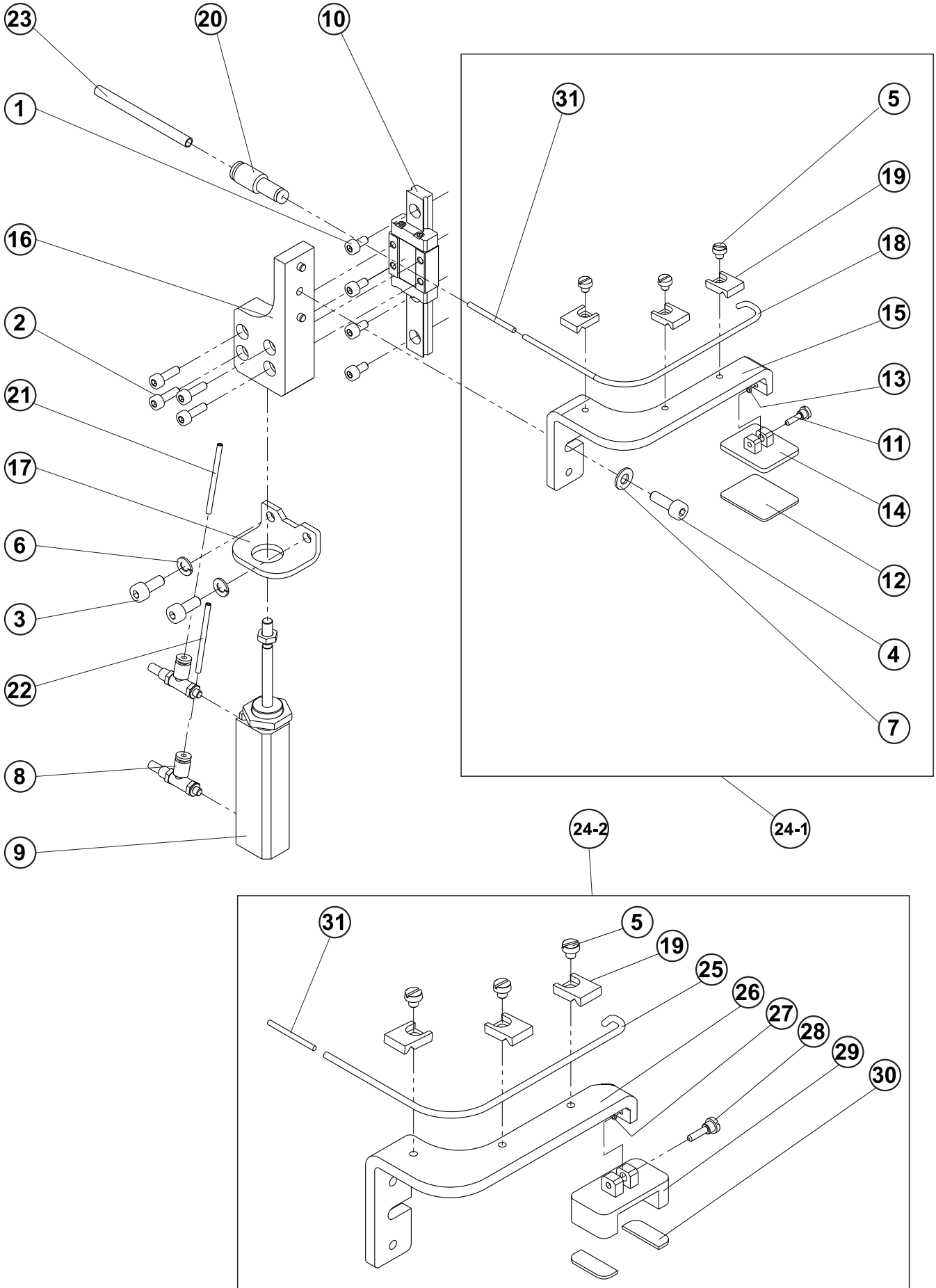

FABRIC HOLDER

DET	PART NUMBER	DESCRIPTION	QTY.
01	08.6002.3.006	SCREW M3-6	4
02	08.6002.3.010	SCREW M3-10	4
03	08.6002.4.010	SCREW M4-10	2
04	08.6002.4.012	SCREW M4-12	1
05	08.6012.3.003	SCREW M3-3	(3)+(3)
06	08.6802.4.000	SPRING WASHER M4	2
07	08.6852.4.000	WASHER M4	1
08	12.0008.3.810	SPEED CONTROLER	2
09	12.0010.3.184	CYLINDER	1
10	12.2070.1.015	GUIDE SEBV10-75	1
11	24.2076.0.000	SCREW M3,5x0,35	(1)
12	73.0238.0.992	ANTI-SLIP MAT	(1)
13	12.3015.2.005	SPRING WASHER	(1)
14	73.0230.0.600	PLATE	(1)
15	73.0231.1.800	FABRIC HOLDER	(1)
16	73.0234.0.600	HOLDER	1
17	73.0235.0.800	HOLDER	1
18	73.0233.0.200	TUBBING	(1)
19	73.0232.0.600	TUBE HOLDER	(3)+(3)
20	12.0010.3.186	CONNECTOR	1
21	12.0008.3.749	AIR TUBING - J11B	1
22	12.0010.3.103	AIR TUBING - J11A	1
23	12.0010.3.080	AIR TUBING - J2A	1
24-1	73.9904.1.056	FABRIC HOLDER ASSEMBLY-STANDARD	1
24-2	73.9904.1.055	FABRIC HOLDER ASSEMBLY-SLEEVE	
25	73.0249.0.200	TUBBING	3
26	73.0237.1.800	FABRIC HOLDER	(1)
27	12.3015.2.005	SPRING WASHER	(1)
28	24.2076.0.000	SCREW M3, 5X0, 35	(1)
29	73.0236.0.600	PLATE	(1)
30	73.0250.0.992	ANTI-SLIP MAT	(2)
31	12.0010.3.103	AIR TUBING L=34mm	(1)

PINCERS

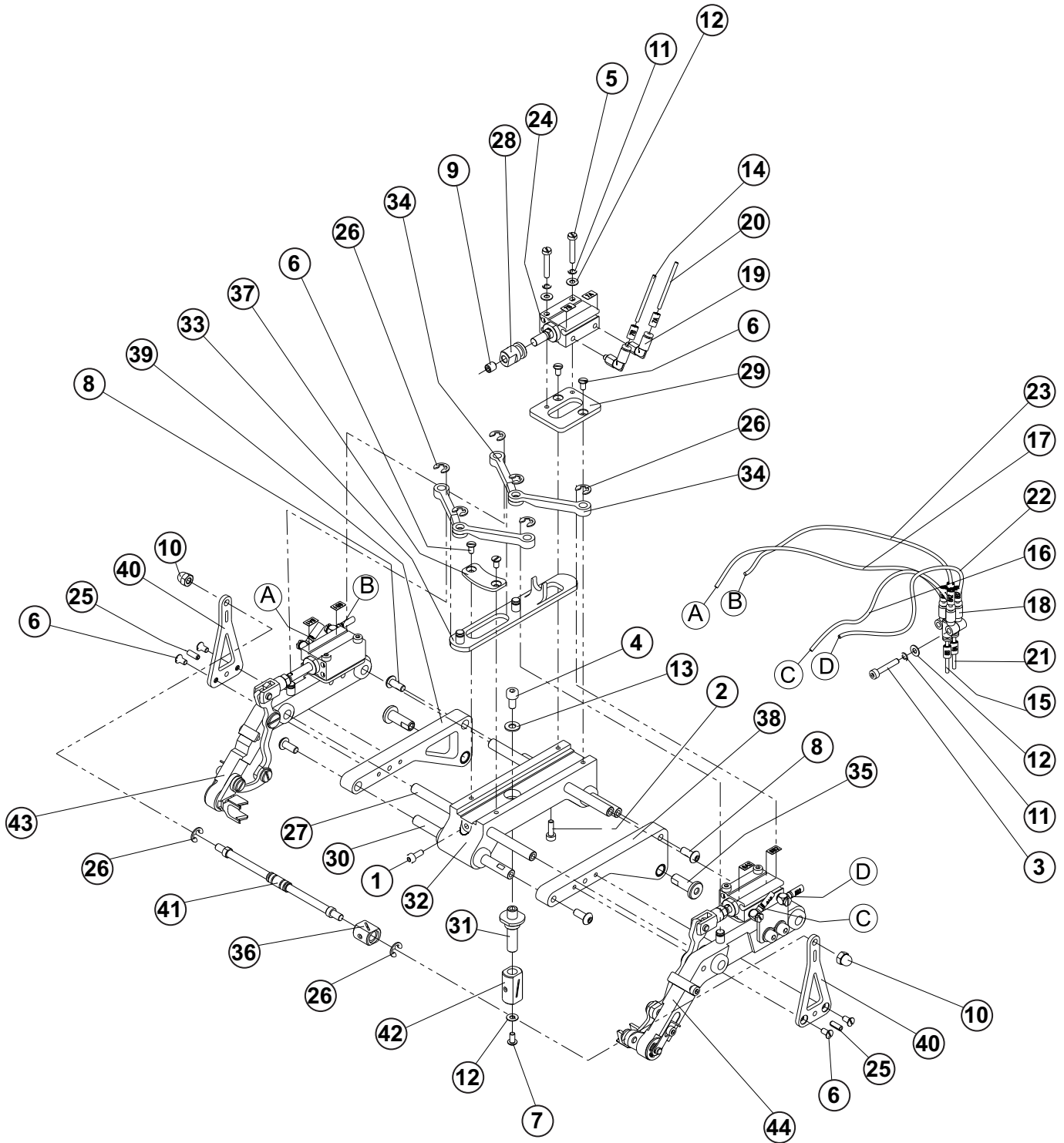

PINCERS

DET	PART NUMBER	DESCRIPTION	QTY.
01	08.6002.3.008	SCREW M3-8	1
02	08.6002.3.010	SCREW M3-10	1
03	08.6002.3.018	SCREW M3-18	1
04	08.6002.4.008	SCREW M4-8	1
05	08.6012.3.018	SCREW M3-18	2
06	08.6112.3.006	SCREW M3-6	8
07	08.6202.3.006	SCREW M3-6	1
08	08.6202.4.010	SCREW M4-10	4
09	08.6400.5.006	SCREW M5-6	1
10	08.6722.4.000	NUT M4	2
11	08.6802.3.000	SPRING WASHER M3	3
12	08.6852.3.000	WASHER M3	4
13	08.6852.4.000	WASHER M4	1
14	12.0008.3.749	AIR TUBING - J7B	-
15	12.0008.3.749	AIR TUBING - J8B	-
16	12.0008.3.749	AIR TUBING - J8B2	-
17	12.0008.3.749	AIR TUBING - J8B1	-
18	12.0010.3.065	SMC CONNECTOR	2
19	12.0010.3.072	CONNECTOR	2
20	12.0010.3.103	AIR TUBING - J7A	-
21	12.0010.3.103	AIR TUBING - J8A	-
22	12.0010.3.103	AIR TUBING - J8A2	-
23	12.0010.3.103	AIR TUBING - J8A1	-
24	12.0010.3.125	CYLINDER	1
25	12.1014.0.308	PIN 3x8	2
26	12.1045.0.004	RETAINING RING 4	8
27	73.0068.0.300	BAR	2
28	73.0070.0.300	NUT	1
29	73.0071.0.800	PLATE	1
30	73.0072.0.300	BAR	2
31	73.0073.0.300	STUD	1
32	73.0145.0.050	BLOCK ASSY.	1
33	73.0146.0.800	LEVER	1
34	73.0147.0.600	LINK	4
35	73.0148.0.300	STUD	2
36	73.0149.0.600	STONE	1
37	73.0150.0.800	PLATE	1
38	73.0151.0.600	ARM RIGHT	1
39	73.0152.0.600	ARM LEFT	1
40	73.0153.0.800	BRACKET	2
41	73.0154.0.300	BAR	1
42	73.0155.0.600	STONE	1
43	73.9005.0.050	ARM LEFT - ASSEMBLY	1
44	73.9006.0.050	ARM RIGHT - ASSEMBLY	1

PINCERS - ARM LEFT

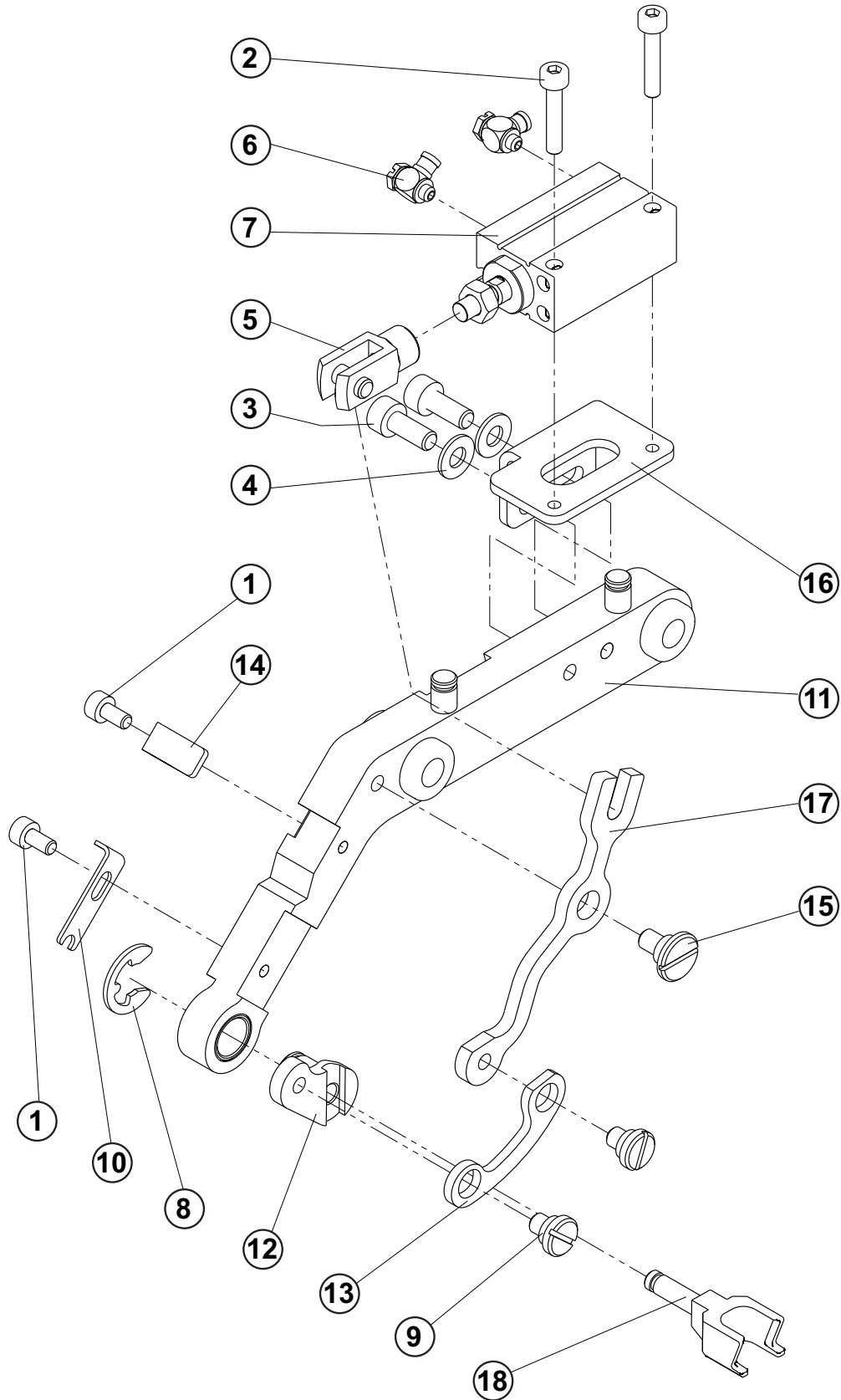

PINCERS - ARM RIGHT

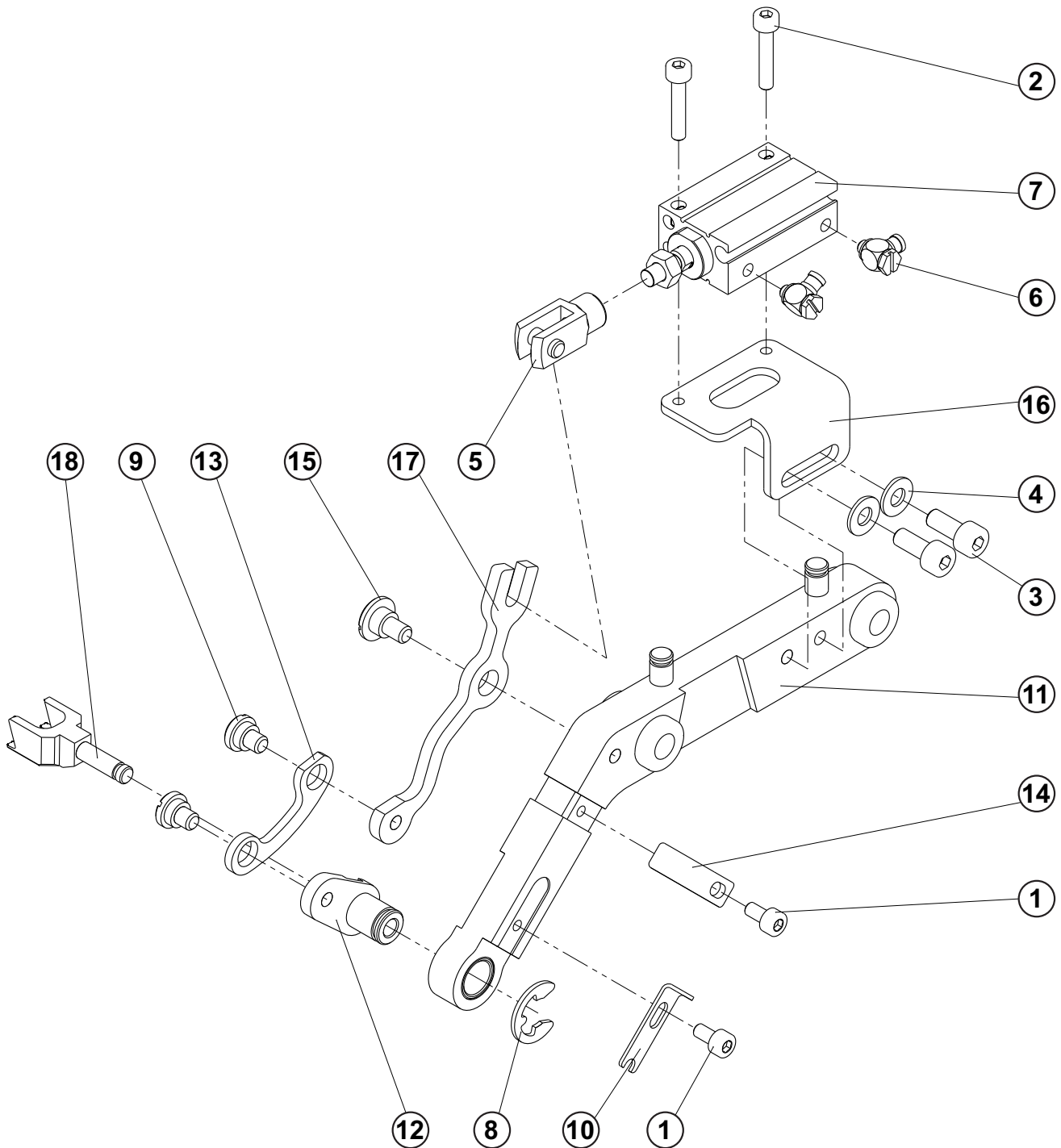

PINCERS - ARM RIGHT

DET	PART NUMBER	DESCRIPTION	QTY.
01	08.6002.3.006	SCREW M3-6	2
02	08.6002.3.016	SCREW M3-16	2
03	08.6002.4.010	SCREW M4-10	2
04	08.6852.4.000	WASHER M4	2
05	12.0008.3.738	KNUCKLE	1
06	12.0008.3.826	CONNECTOR	2
07	12.0010.3.124	CYLINDER	1
08	12.1045.0.007	RETAINER RING 7	1
09	24.0061.0.000	THREAD TAKE-UP SHOULDER SCREW	2
10	73.0069.0.800	STOP	1
11	73.0162.0.600	ARM RIGHT	1
12	73.0164.0.600	LEVER RIGHT	1
13	73.0167.0.800	LINK	1
14	73.0168.0.800	STOP	1
15	73.0169.0.100	STUD	1
16	73.0326.0.800	HOLDER - RIGHT	1
17	73.0327.0.800	LEVER	1
18	73.9901.0.601	CHUCK "M"	1

THREAD DRAW - OFF

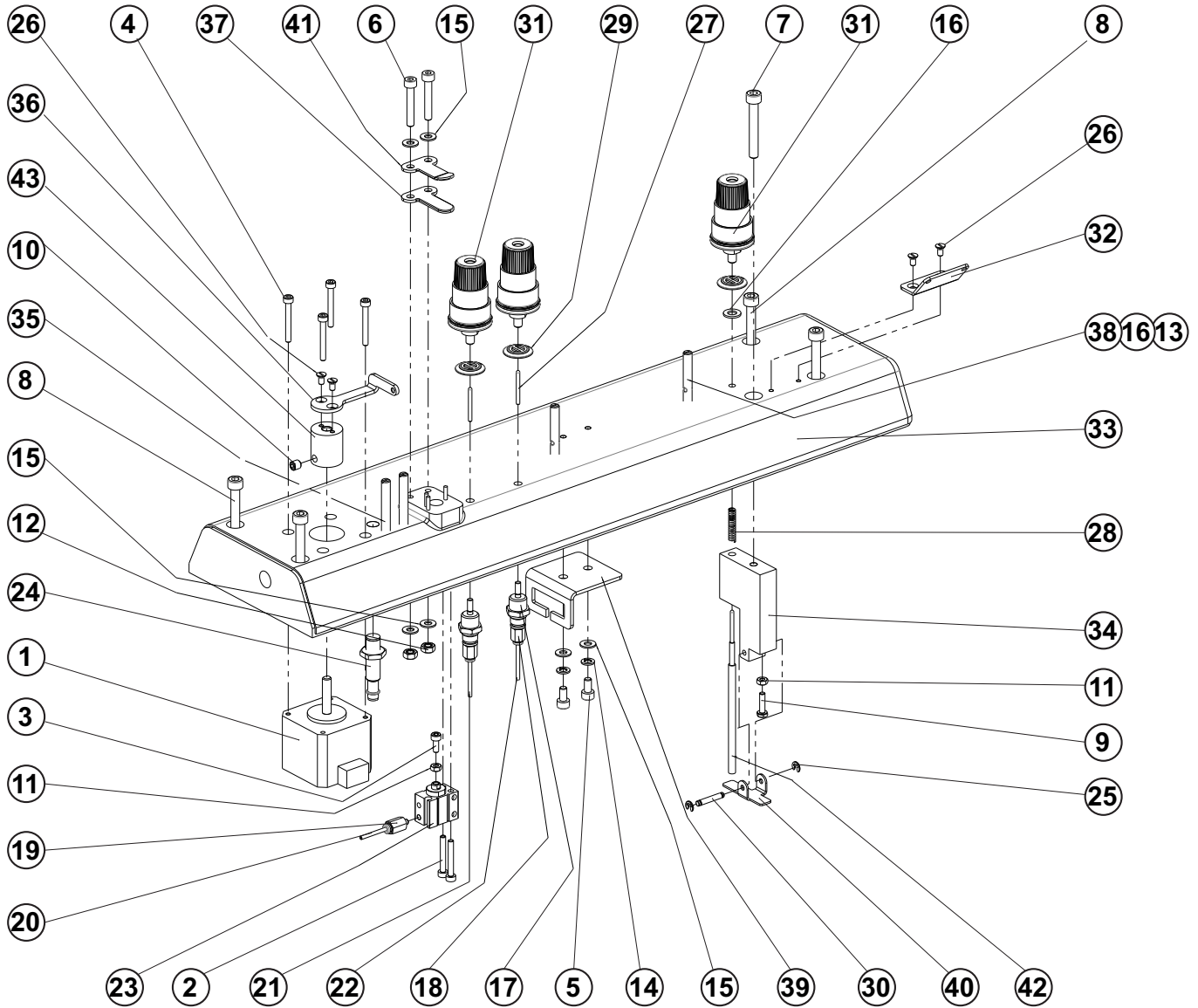

THREAD DRAW - OFF

DET	PART NUMBER	DESCRIPTION	QTY.
01	06.7300.0.025	STEPPER MOTOR U5 ASSY.	1
02	08.6000.3.022	SCREW M3-22	2
03	08.6002.3.008	SCREW M3-8	1
04	08.6002.3.025	SCREW M3-25	4
05	08.6002.4.008	SCREW M4-8	2
06	08.6002.4.025	SCREW M4-25	2
07	08.6002.5.035	SCREW M5-35	1
08	08.6002.5.040	SCREW M5-40	4
09	08.6310.3.012	SCREW M3x12	1
10	08.6410.5.005	SCREW M5-5	1
11	08.6702.3.000	NUT M3	2
12	08.6702.4.000	NUT M4	2
13	08.6702.5.000	NUT M5	2
14	08.6802.4.000	SPRING WASHER M4	2
15	08.6852.4.000	WASHER M4	6
16	08.6852.5.000	WASHER 5,3	3
17	12.0008.3.413	CYLINDER	2
18	12.0010.3.070	CONNECTOR	2
19	12.0010.3.071	CONNECTOR	1
20	12.0010.3.103	AIR TUBING - J15A	1
21	12.0010.3.103	AIR TUBING - J12A	1
22	12.0010.3.103	AIR TUBING - J13A	1
23	12.0010.3.126	CYLINDER	1
24	12.0010.4.093	SENSOR	1
25	12.1045.0.001	E-CLIP 2,3	2
26	15.1436.0.100	SCREW M3-6	4
27	15.3206.0.300	PIN 2x21	2
28	17.0026.0.222	SPRING	1
29	17.0082.8.082	TENSION DISC	3
30	19.0031.8.412	STUD	1
31	24.0119.0.050	TENSION DISC ASSY.	3
32	50.0046.0.800	THREAD GUIDE	1
33	73.0062.0.600	UPPER COVER	1
34	73.0063.0.600	HOLDER	1
35	73.0064.0.300	STUD	2
36	73.0065.0.800	THREAD DRAW-OFF LEVER	1
37	73.0066.0.800	THREAD CLAMP LOWER	1
38	73.0067.0.300	THREAD GUIDE	2
39	73.0084.0.800	CABLE HOLDER	1
40	73.0221.0.800	SHAFT ACTUATOR	1
41	73.0226.0.800	THREAD CLAMP UPPER	1
42	73.0227.0.300	SHAFT	1
43	73.0228.0.400	LEVER HOLDER	1

DISPLAY PANEL

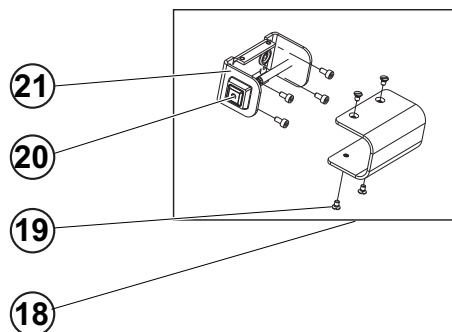
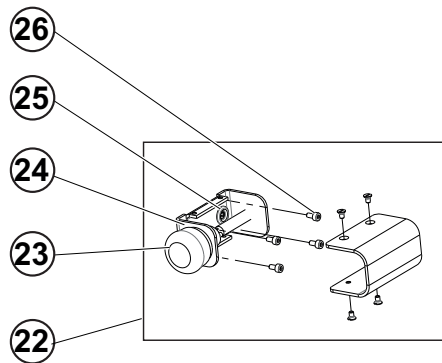
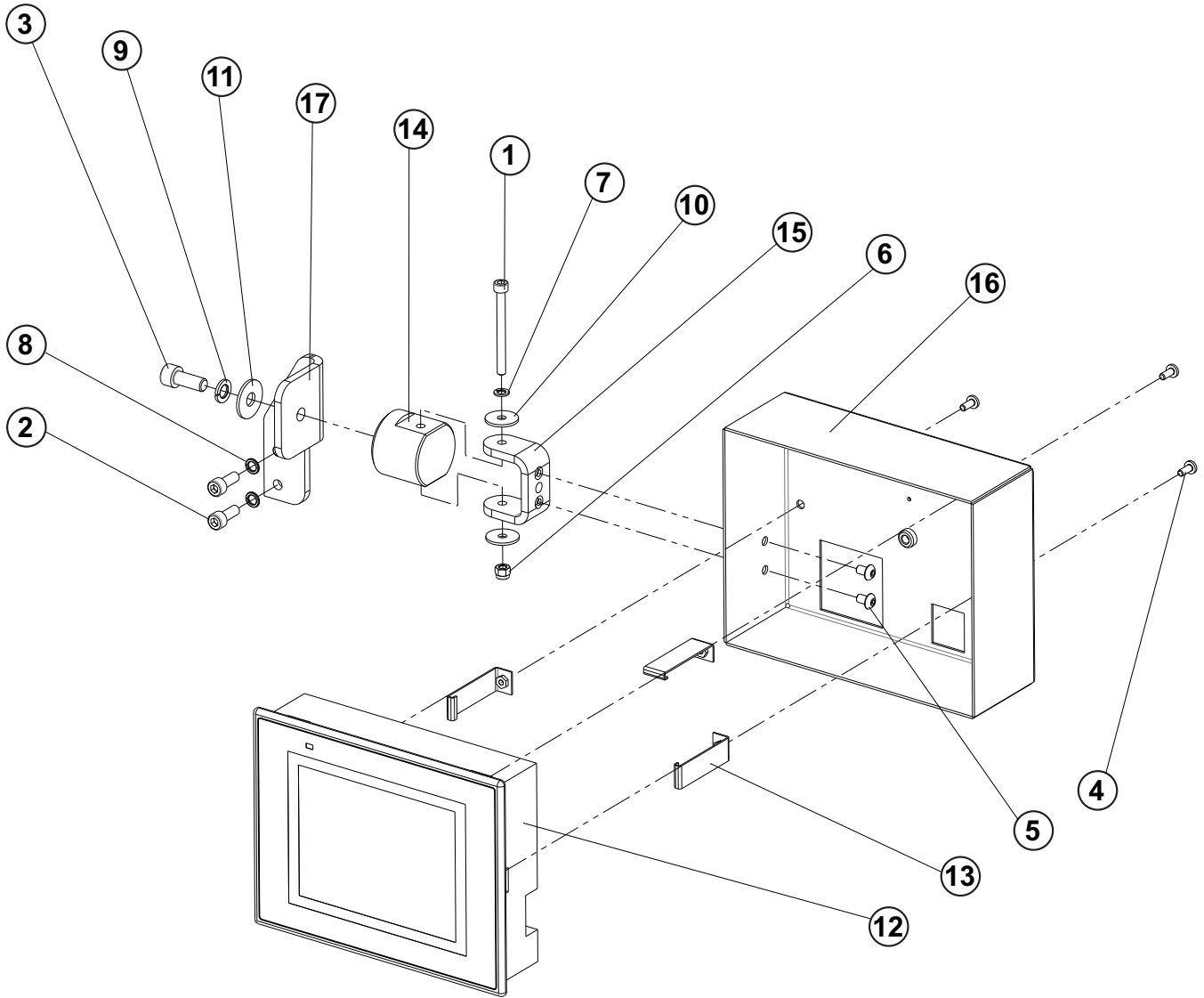

DISPLAY PANEL

DET	PART NUMBER	DESCRIPTION	QTY.
01	08.6002.5.055	SCREW M5-55	1
02	08.6002.6.016	SCREW M6-16	2
03	08.6002.8.020	SCREW M8-20	1
04	08.6032.4.010	SCREW M4-10	3
05	08.6202.5.008	SCREW M5-8	2
06	08.6732.5.000	NUT M5 EN	1
07	08.6802.5.000	SPRING WASHER M5	1
08	08.6802.6.000	SPRING WASHER M6	2
09	08.6802.8.000	SPRING WASHER M8	1
10	08.6882.5.000	WASHER 5,3x20-1,5	2
11	08.6882.8.000	WASHER M8	1
12	12.0010.4.300	DISPLAY	1
13	24.0168.0.000	DISPLAY HOLDER - OMRON	3
14	68.0356.1.300	STUD	1
15	68.0357.0.800	BRACKET	1
16	68.0358.0.800	PANEL COVER	1
17	73.0087.0.800	DISPLAY HOLDER	1
18	73.0085.0.050	BUTTON COVER-ASSY.	1
19	15.1436.0.100	SCREW M3-5	(8)
20	06.7300.0.053	START BUTTON ASSY.	(1)
21	73.0085.0.000	BUTTON COVER	(1)
22	73.0086.0.050	EMERGENCY STOP ASSY.	1
23	06.7300.0.054	EMERGENCY STOP BUTTON ASSY.	(1)
24	15.1405.0.000	STOP COVER	(1)
25	12.0008.4.214	BUSHING HV6	(2)
26	08.6000.3.006	SCREW M3-6	(8)

STAND

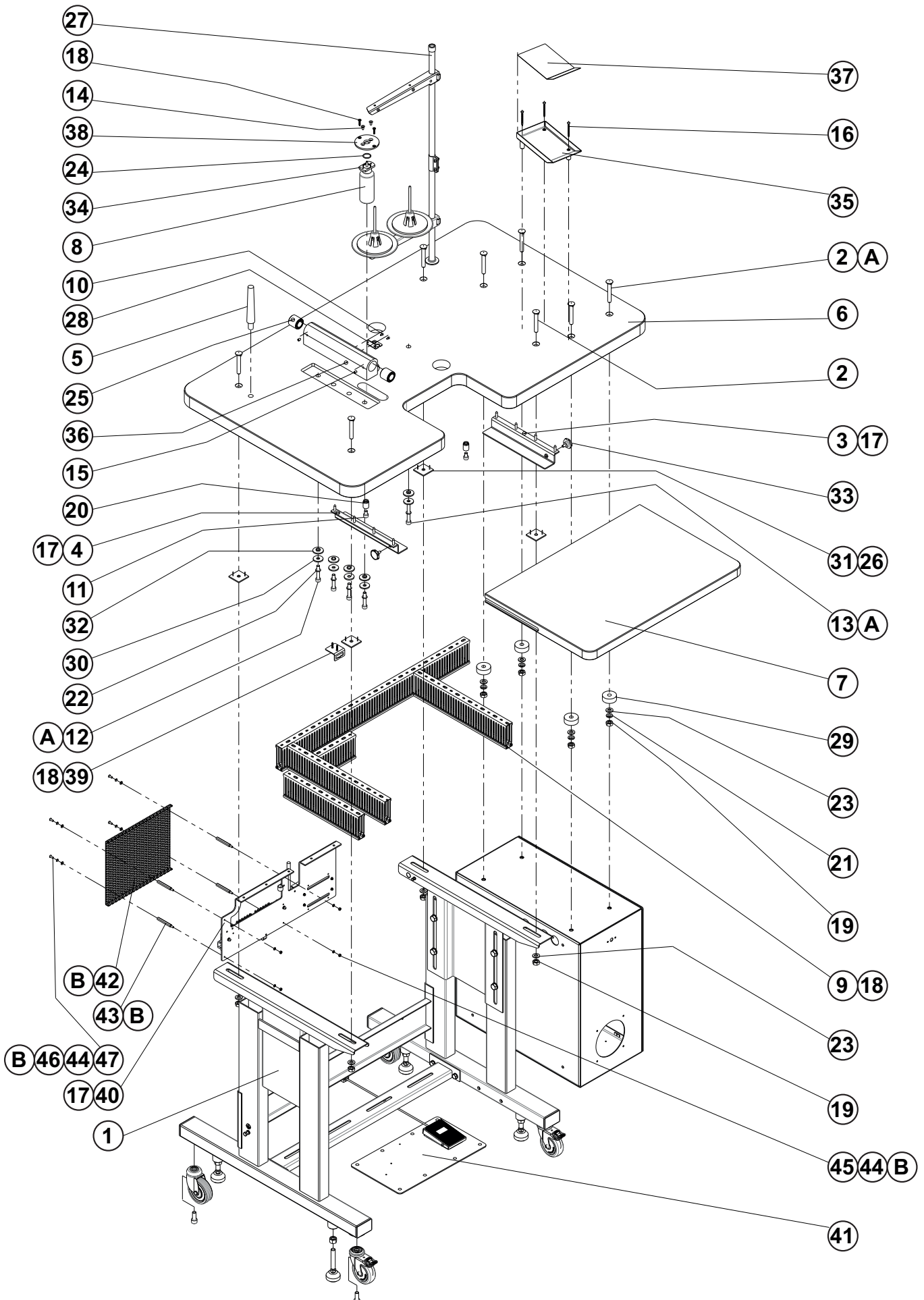

STAND

DET	PART NUMBER	DESCRIPTION	QTY.
01	04.9015.0.000	FRAME KIT	1
02	04.9015.0.362	SCREW M10-70	8
03	04.9073.0.361	GUIDE TABLE - RIGHT	1
04	04.9073.0.362	GUIDE TABLE - LEFT	1
05	04.9073.0.363	MACHINE REST TABLE PIN	1
06	04.9073.0.900	TABLE TOP	1
07	04.9073.0.901	TABLE - BOTTOM	1
08	05.1322.0.000	OIL RESERVOIR	1
09	06.7300.0.007	LATCH FOR CABLE TABLE CBS13	1
10	08.6002.3.006	SCREW M3-6	2
11	08.6002.8.012	SCREW M8-12	2
12	08.6002.8.045	SCREW M8-45	4
13	08.6002.8.065	SCREW M8-65	1
14	08.6102.5.010	SCREW M5-10	2
15	08.6402.6.008	SCREW M6-8	2
16	08.6646.4.050	SCREW 4-50	3
17	08.6663.5.025	SCREW 4,8-25	13
18	08.6676.3.020	SCREW ST3,5-20	22
19	08.6702.0.000	NUT M10	8
20	08.6752.8.000	NUT M8	2
21	08.6802.0.000	SPRING WASHER M10	4
22	08.6802.8.000	SPRING WASHER M8	5
23	08.6852.0.000	WASHER 10,5	8
24	12.0008.6.812	O-RING 19x2	1
25	12.0008.6.821	VIBRATION-DAMPING BRONZE BEARING	2
26	12.1016.1.000	NAIL 1,6x20	8
27	12.9900.9.005	THREAD STAND ASSY.JUKI 2-THREAD	1
28	15.1145.0.800	SERVO CABLE HOLDER	1
29	15.6005.0.990	SHOCK MOUNT	4
30	17.0019.0.441	WASHER	5
31	17.0094.0.200	WASHER	4
32	17.0095.1.272	RUBBER WASHER	5
33	19.0014.7.003	SCREW-PANEL	2
34	19.0044.5.404	HOLDER	1
35	71.1570.0.037	RESERVOIR	1
36	73.0079.0.600	HEAD HOLDER	1
37	73.0080.0.990	ANTI-SLIP MAT	1
38	73.0083.0.800	HOLDER	1
39	73.0084.0.800	CABLE HOLDER	1
40	73.7002.1.050	VALVE BLOCK ASSY.	1
41	73.9008.0.050	PEDAL ASSY.	1
42	73.0342.0.800	COVER	1
43	73.0343.0.100	DISTANCE NUT	4
44	08.6802.4.000	SPRING WASHER M4	8
45	08.6702.4.000	NUT M4 DIN 934	4
46	08.6852.4.000	WASHER M4	4
47	08.6202.4.010	SCREW M4-10	4

PEDAL

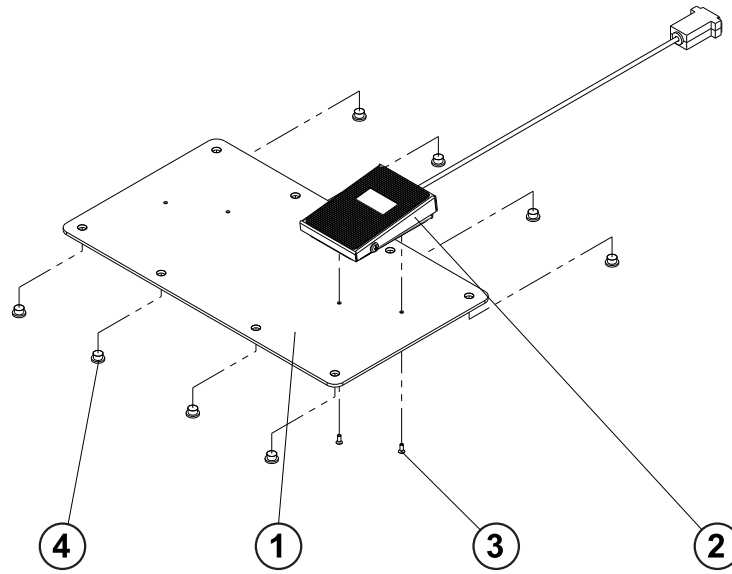

PEDAL

DET	PART NUMBER	DESCRIPTION	QTY.
01	04.9015.0.361	PEDAL HOLDER	1
02	06.7300.0.056	CABLE X2 PEDAL BQ1 ASSY.	1
03	08.6100.3.008	SCREW M3-8	2
04	17.0094.0.029	PLUG	8

VALVE BLOCK

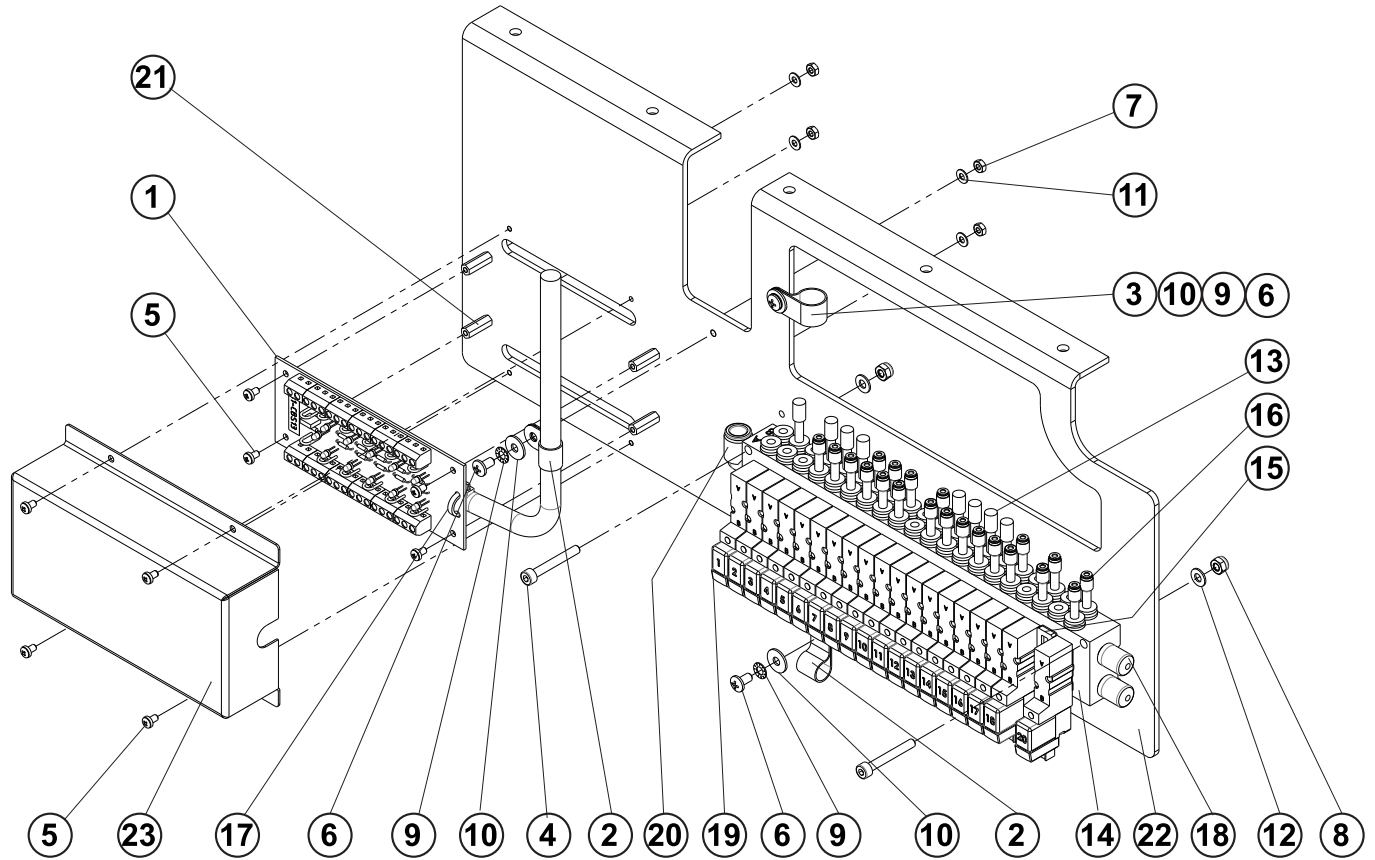

VALVE BLOCK

DET	PART NUMBER	DESCRIPTION	QTY.
01	06.7300.0.055	TB1 ASSY. CBS13	1
02	07.6600.0.004	CLAMP CABLE UCF-1,5	2
03	07.6600.0.006	CLAMP CABLE UCF-3	1
04	08.6002.4.030	SCREW M4-30	2
05	08.6032.3.005	SCREW M3-5	8
06	08.6032.4.008	SCREW M4-8	3
07	08.6702.3.000	NUT M3	4
08	08.6732.4.000	NUT M4	2
09	08.6832.4.000	WASHER M4	3
10	08.6842.4.000	WASHER 4	3
11	08.6852.3.000	WASHER M3	4
12	08.6852.4.000	WASHER M4	2
13	12.0008.3.426	PLUG	8
14	12.0008.3.451	MANIFOLD PLATE	1
15	12.0008.3.790	BLANKING PLATE	1
16	12.0008.3.861	CONNECTOR	21
17	12.0008.4.290	CABLE TIE 2x100	1
18	12.0010.3.099	SILENCER	2
19	12.0010.3.105	5/2 VALVE	19
20	12.0010.3.106	CONNECTOR	1
21	12.0010.4.303	DISTANCE NUT DA5 M3x8	4
22	73.0081.0.800	VALVE HOLDER	1
23	73.0082.0.800	COVER	1

ARM AND BASE

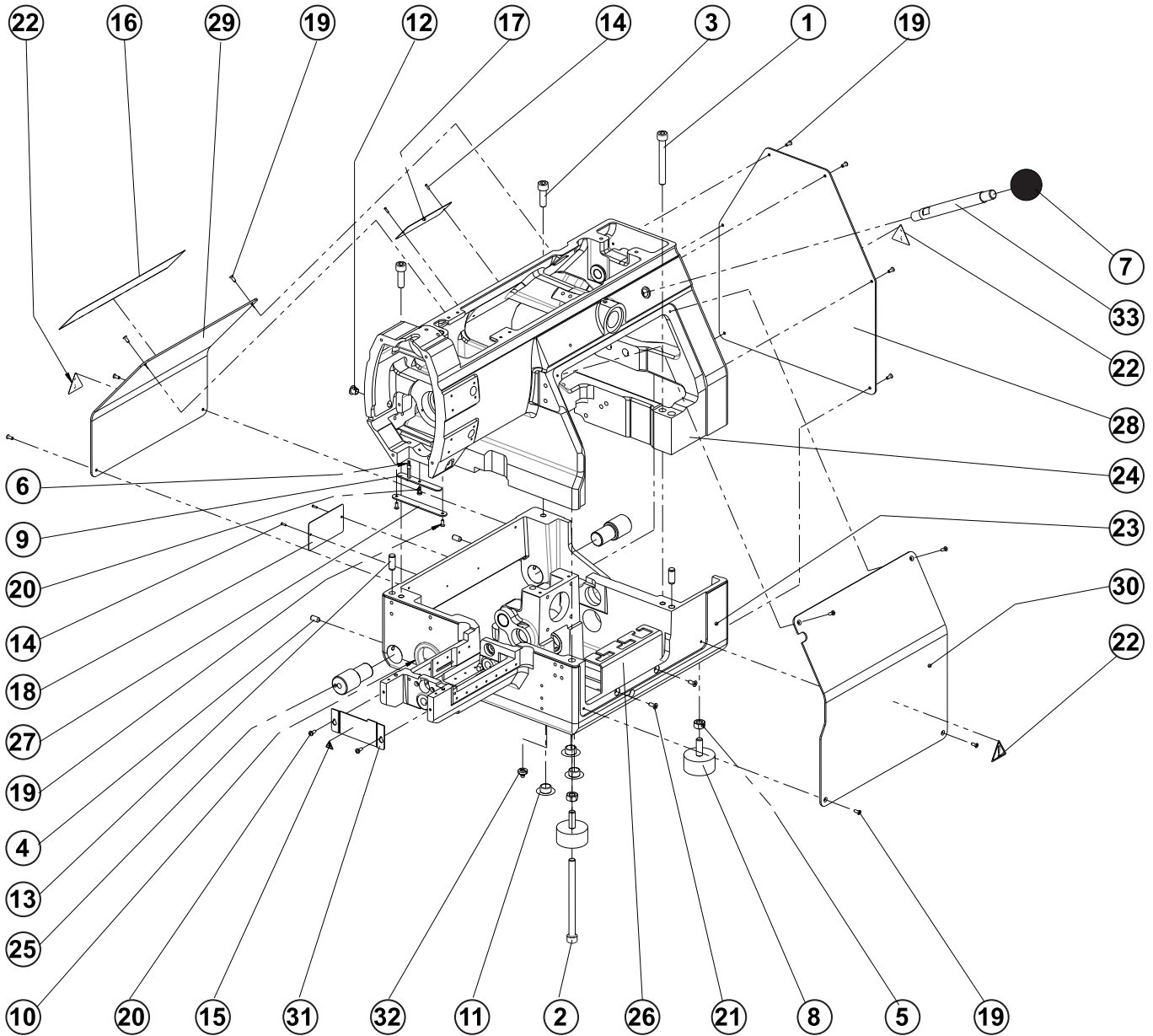

ARM AND BASE

DET	PART NUMBER	DESCRIPTION	QTY.
01	08.6000.8.065	SCREW M8-65	1
02	08.6000.8.110	SCREW M8-110	1
03	08.6002.8.025	SCREW M8-25	2
04	08.6402.6.012	SCREW M6-12	2
05	08.6702.8.000	NUT M8	2
06	12.0008.4.146	CABLE END 0,5/8mm INSULATED	2
07	12.0008.6.530	HANDLE	1
08	12.0008.6.820	RUBBER SPRING	2
09	12.0010.4.310	CBS LED LIGHT 24V	1
10	12.0010.4.321	BUSHING HVH 41	1
11	12.0010.6.906	PLUG 14,4/24/7	3
12	12.0010.6.916	PLUG 8/12/7	1
13	12.1010.3.001	PIN 8-20	2
14	12.1016.0.002	NAIL 1.86x6.35 (1/4)	4
15	12.8000.0.437	LABEL-DANGER INJURY	1
16	12.8000.0.445	LABEL AMF REECE 220x46	1
17	12.8000.1.039	LABEL CBS 13	1
18	12.8000.1.050	LABEL CE CBS 13	1
19	15.1420.0.100	SCREW M3-8	14
20	15.1425.0.100	SCREW M3-8	3
21	15.1427.0.100	SCREW M4-10	2
22	17.0097.5.174	LABEL- WARNING	3
23	73.0054.0.700	BASE	1
24	73.0060.0.700	ARM	1
25	73.0091.0.300	STUD	2
26	73.0321.0.800	CABLE HOLDER	1
27	73.0093.0.992	LED LIGHT COVER	1
28	73.0157.0.800	BACK COVER	1
29	73.0158.0.800	LEFT COVER	1
30	73.0159.0.800	RIGHT COVER	1
31	73.0160.0.800	LOOPER COVER	1
32	73.0222.0.100	NIPPLE, LUBRICATING M12x1,25	1
33	73.0295.0.300	BAR	1
34	08.6202.3.006	SCREW M3-6	2

THREAD PICK-UP

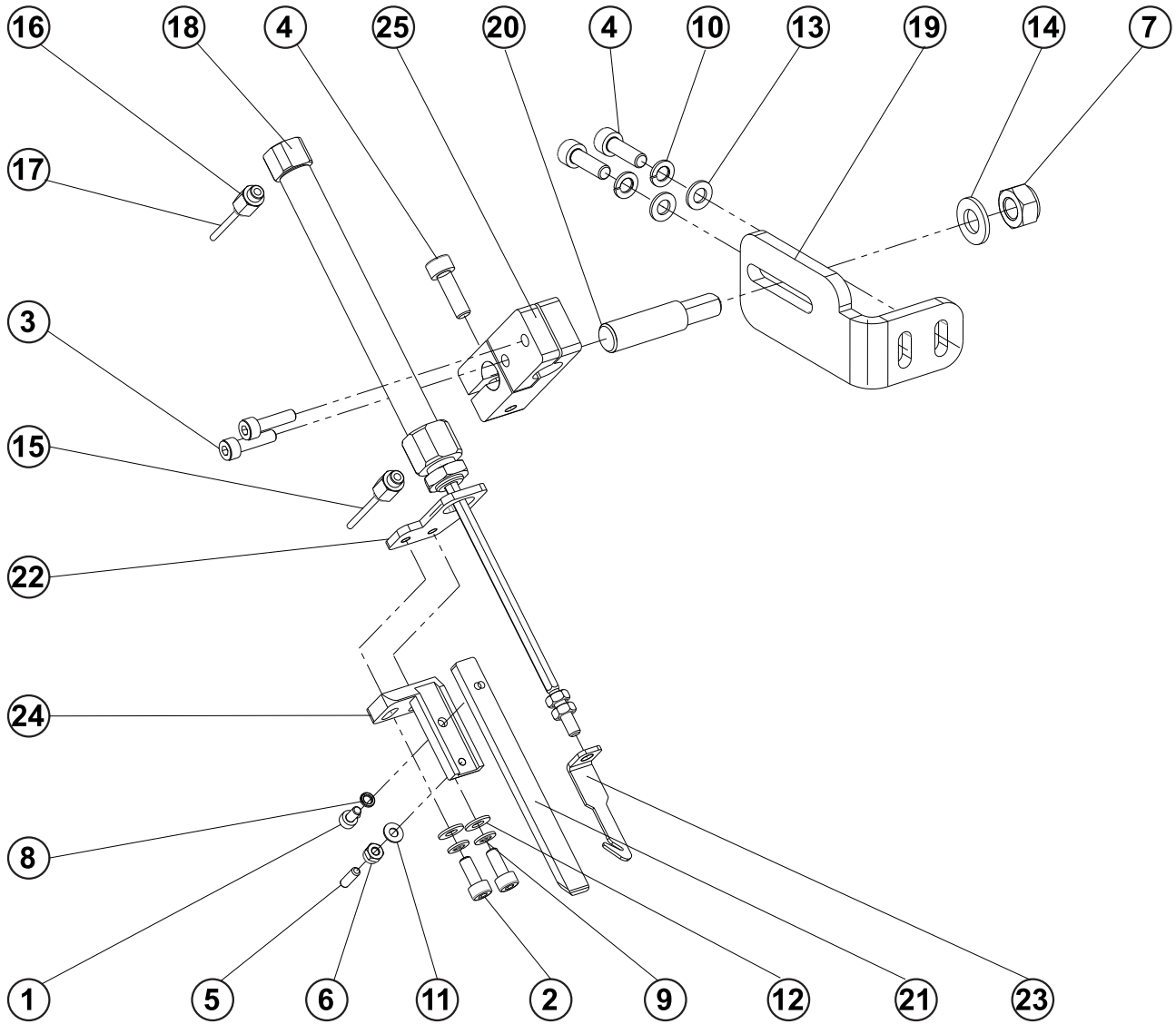

THREAD PICK-UP

DET	PART NUMBER	DESCRIPTION	QTY.
01	08.6002.3.006	SCREW M3-6	1
02	08.6002.4.010	SCREW M4-10	2
03	08.6002.4.016	SCREW M4-16	2
04	08.6002.5.016	SCREW M5-16	3
05	08.6402.3.010	SCREW M3-10	1
06	08.6733.3.000	NUT M3	1
07	08.6733.8.000	NUT M8	1
08	08.6802.3.000	SPRING WASHER M3	1
09	08.6802.4.000	SPRING WASHER M4	2
10	08.6802.5.000	SPRING WASHER M5	2
11	08.6852.3.000	WASHER M3	1
12	08.6852.4.000	WASHER M4	2
13	08.6852.5.000	WASHER 5,3	2
14	08.6852.8.000	WASHER M8	1
15	12.0008.3.749	AIR TUBING - J19B	1,5m
16	12.0010.3.070	CONNECTOR	2
17	12.0010.3.103	AIR TUBING - J18A	1,5m
18	12.0010.3.128	CYLINDER	1
19	73.0077.0.800	BRACKET	1
20	73.0078.0.300	SHAFT	1
21	73.0245.0.800	THREAD SUPPORT	1
22	73.0246.0.800	BRACKET	1
23	73.0247.0.800	PICK-UP	1
24	73.0248.0.600	HOLDER	1
25	73.0251.0.600	CYLINDER HOLDER	1

NEEDLE COVER

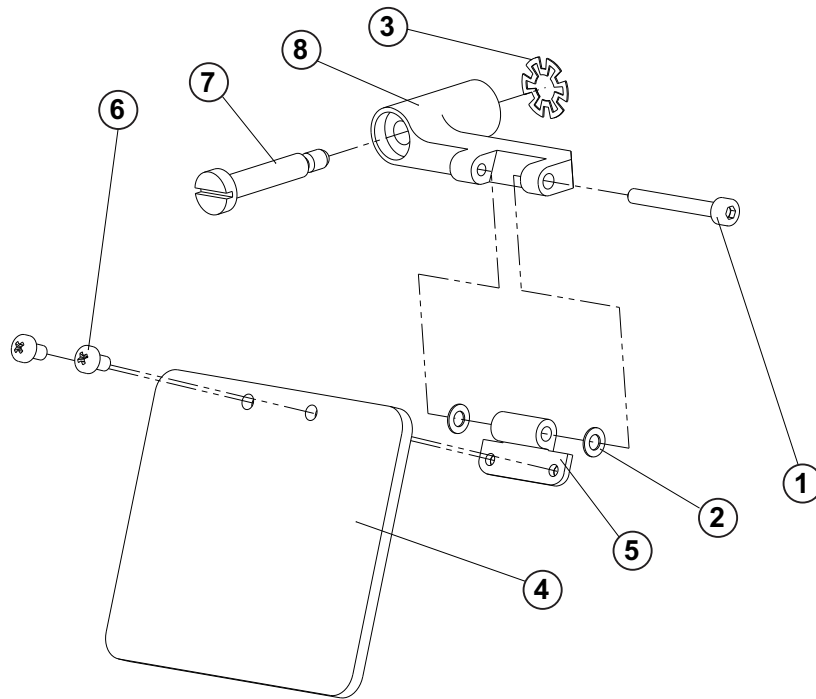

FRONT COVER

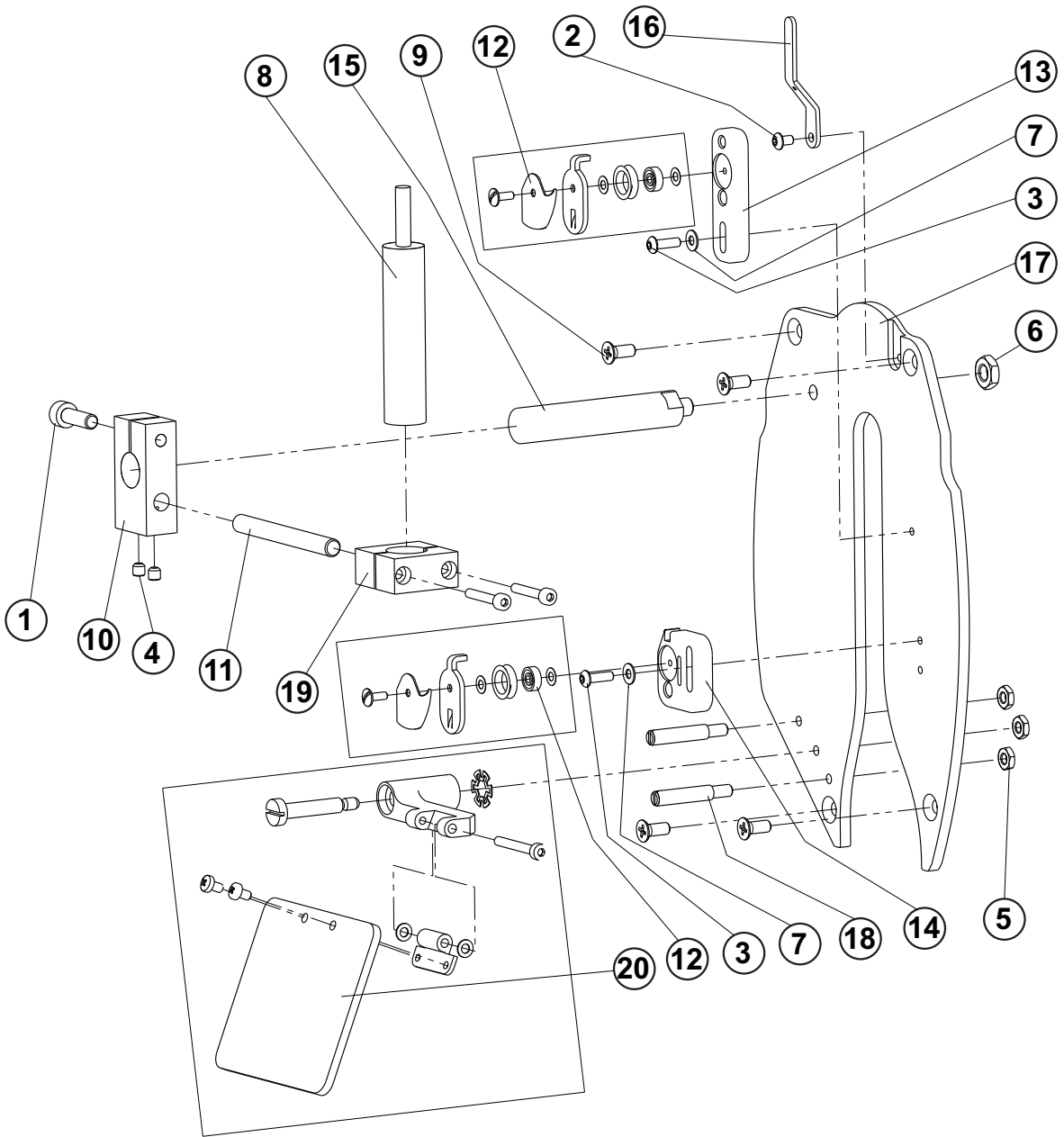

FRONT COVER

DET	PART NUMBER	DESCRIPTION	QTY.
01	08.6002.5.016	SCREW M5-16	1
02	08.6200.3.005	SCREW M3-5	1
03	08.6202.3.010	SCREW M3-10	2
04	08.6410.4.004	SCREW M4-4	2
05	08.6712.4.000	NUT M4	3
06	08.6712.6.000	NUT M6	1
07	08.6852.3.000	WASHER M3	2
08	12.0010.4.311	LASER LR14CD CROSS RED	1
09	15.1427.0.100	SCREW M4-10	4
10	68.0158.0.600	HOLDER	1
11	68.0159.0.300	STUD	1
12	73.0015.0.050	TENSION ROLLER ASSY.	2
13	73.0019.0.600	HOLDER	1
14	73.0020.0.600	HOLDER	1
15	73.0042.0.100	HOLDER	1
16	73.0051.0.800	THREAD GUIDE	1
17	73.0131.0.800	FRONT COVER	1
18	73.0198.0.100	PIN	2
19	73.0302.0.600	LASER BRACKET	1
20	73.9022.0.050	NEEDLE COVER - ASSY.	1

NECK WRAPPING

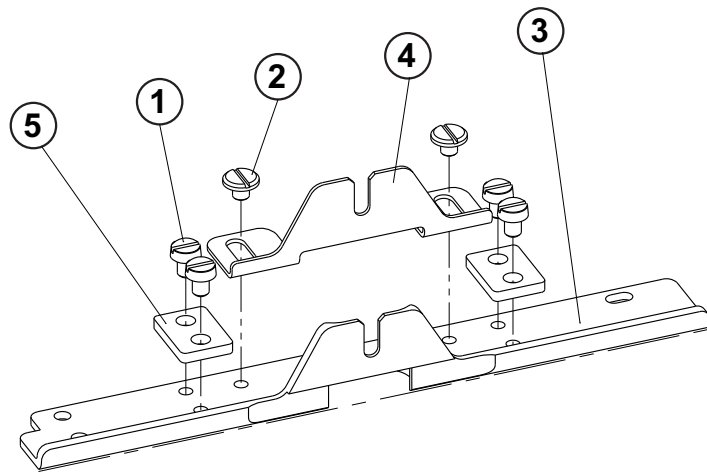

BUTTON FEEDER

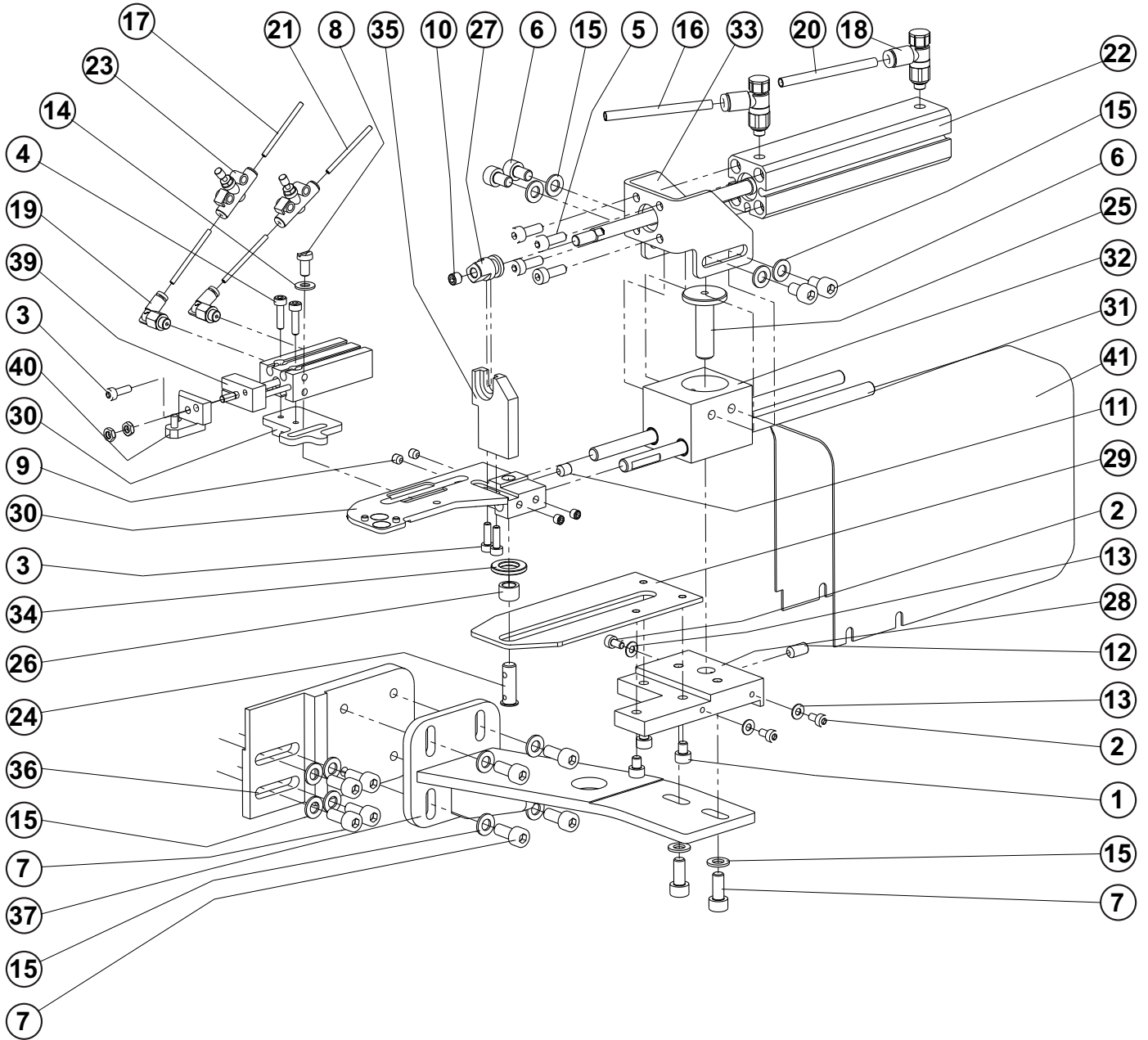

BUTTON FEEDER

DET	PART NUMBER	DESCRIPTION	QTY.
01	08.6000.4.005	SCREW M4-5	3
02	08.6002.3.006	SCREW M3-6	3
03	08.6002.3.010	SCREW M3-10	3
04	08.6002.3.012	SCREW M3-12	2
05	08.6002.4.012	SCREW M4-12	4
06	08.6002.5.008	SCREW M5-8	4
07	08.6002.5.012	SCREW M5-12	10
08	08.6012.4.008	SCREW M4-8	1
09	08.6400.4.004	SCREW M4-4	4
10	08.6400.5.005	SCREW M5-5	1
11	08.6400.5.006	SCREW M5-6	1
12	08.6400.5.010	SCREW M5-10	1
13	08.6852.3.000	WASHER M3	3
14	08.6852.4.000	WASHER M4	1
15	08.6852.5.000	WASHER M5	14
16	12.0008.3.416	AIR TUBE- J17B	1
17	12.0008.3.749	AIR TUBING - J16B	1
18	12.0010.3.047	SPEED CONTR.	2
19	12.0010.3.064	CONNECTOR	2
20	12.0010.3.080	AIR TUBE- J17A	1
21	12.0010.3.103	AIR TUBING - J16A	1
22	12.0010.3.130	CYLINDER	1
23	12.0010.3.192	SPEED CONTR.	2
24	15.4609.0.300	LOOPER LEVER STUD	1
25	17.0032.0.193	STUD	1
26	17.0041.8.003	ROLL	1
27	73.0070.0.300	NUT	1
28	73.0132.0.600	HOLDER	1
29	73.0133.1.800	FEEDER CAM	1
30	73.0134.0.600	HOLDER	1
31	73.0135.0.300	SHAFT	2
32	73.0136.0.600	GUIDE	1
33	73.0137.0.800	CYLINDER HOLDER	1
34	73.0138.1.400	WASHER	1
35	73.0139.0.600	HOLDER	1
36	73.0141.0.600	PLATE	1
37	73.0142.0.000	CONSOLE	1
38	73.0144.0.600	HOLDER	1
39	73.0305.0.000	CYLINDER	1
40	73.0306.0.600	ROD	1
41	73.0313.0.800	COVER	1

BUTTON HOLDER 4-HOLES

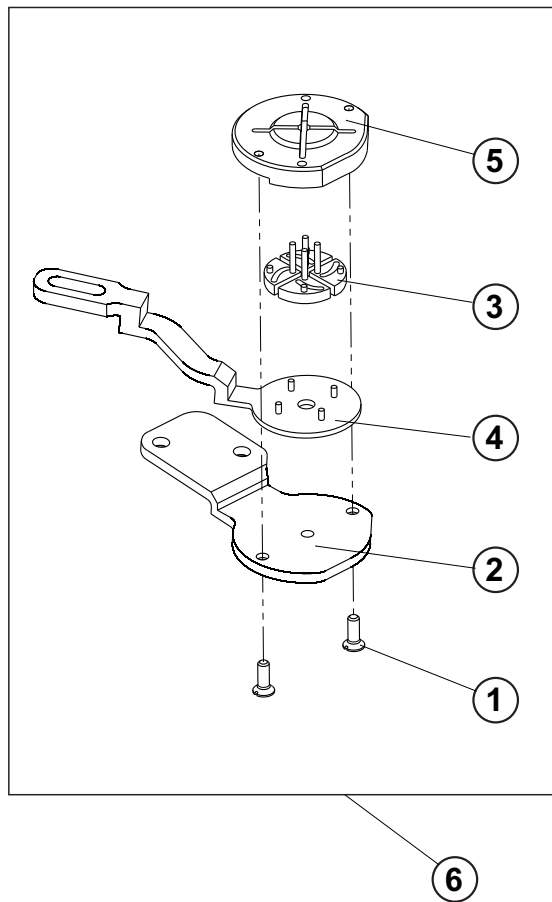

BUTTON HOLDER 4-HOLES

DET	PART NUMBER	DESCRIPTION	QTY.
01	08.6112.2.006	SCREW M2x6	(2)
02	73.0310.0.600	BRACKET	(1)
03	73.0210.0.800	SEGMENT	(4)
04	73.0308.0.600	LEVER	(1)
05	73.0212.0.300	GUIDE	(1)
06	73.9903.0.055	BUTTON HOLDER	1

BUTTON HOLDER 2-HOLES

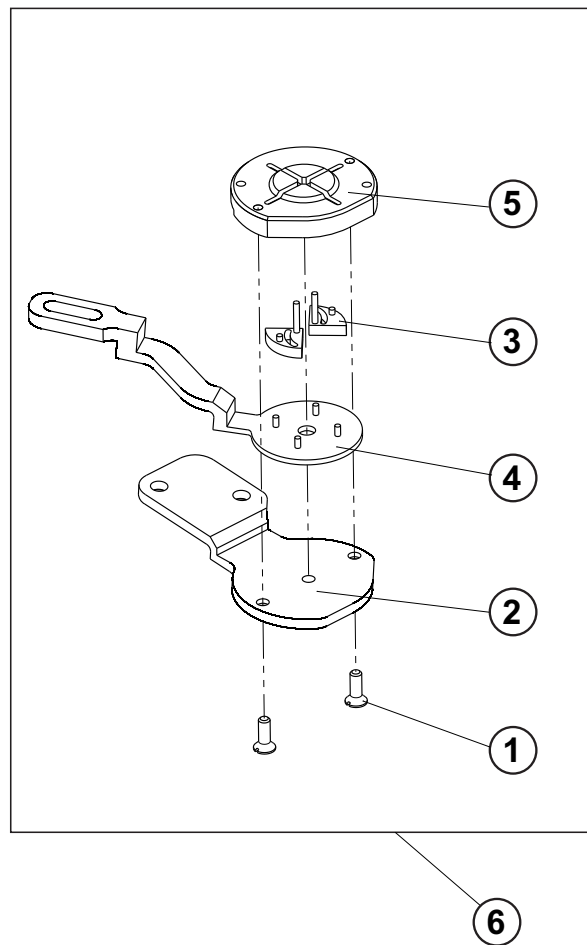

SHANK BUTTON HOLDER

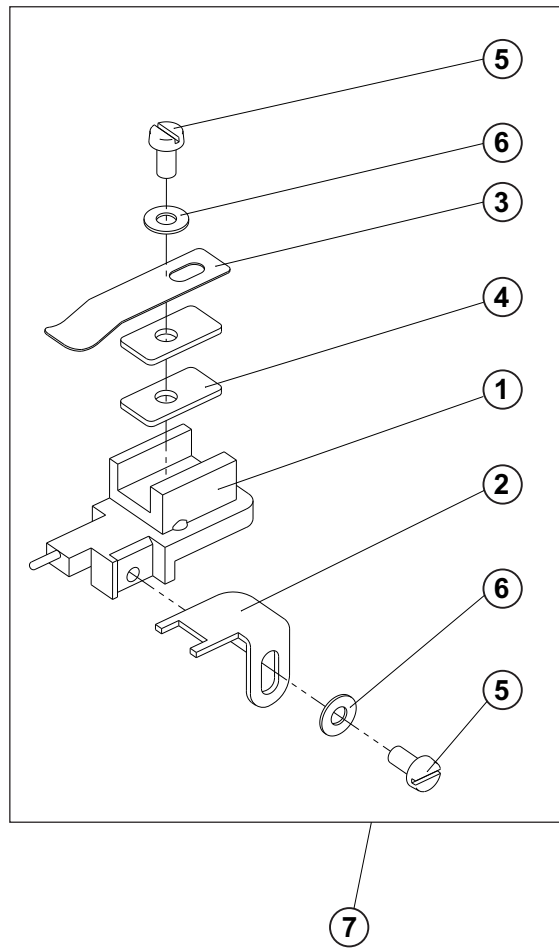

SHANK BUTTON HOLDER

DET	PART NUMBER	DESCRIPTION	QTY.
01	73.0214.0.600	HOLDER	(1)
02	73.0215.0.800	WASHER	(1)
03	73.0216.0.800	SPRING	(1)
04	73.0217.0.800	WASHER	(2)
05	08.6012.3.006	SCREW M3-6	(2)
06	08.6852.3.000	WASHER M3	(2)
07	73.9903.0.054	BUTTON HOLDER	1

LUBRICATING

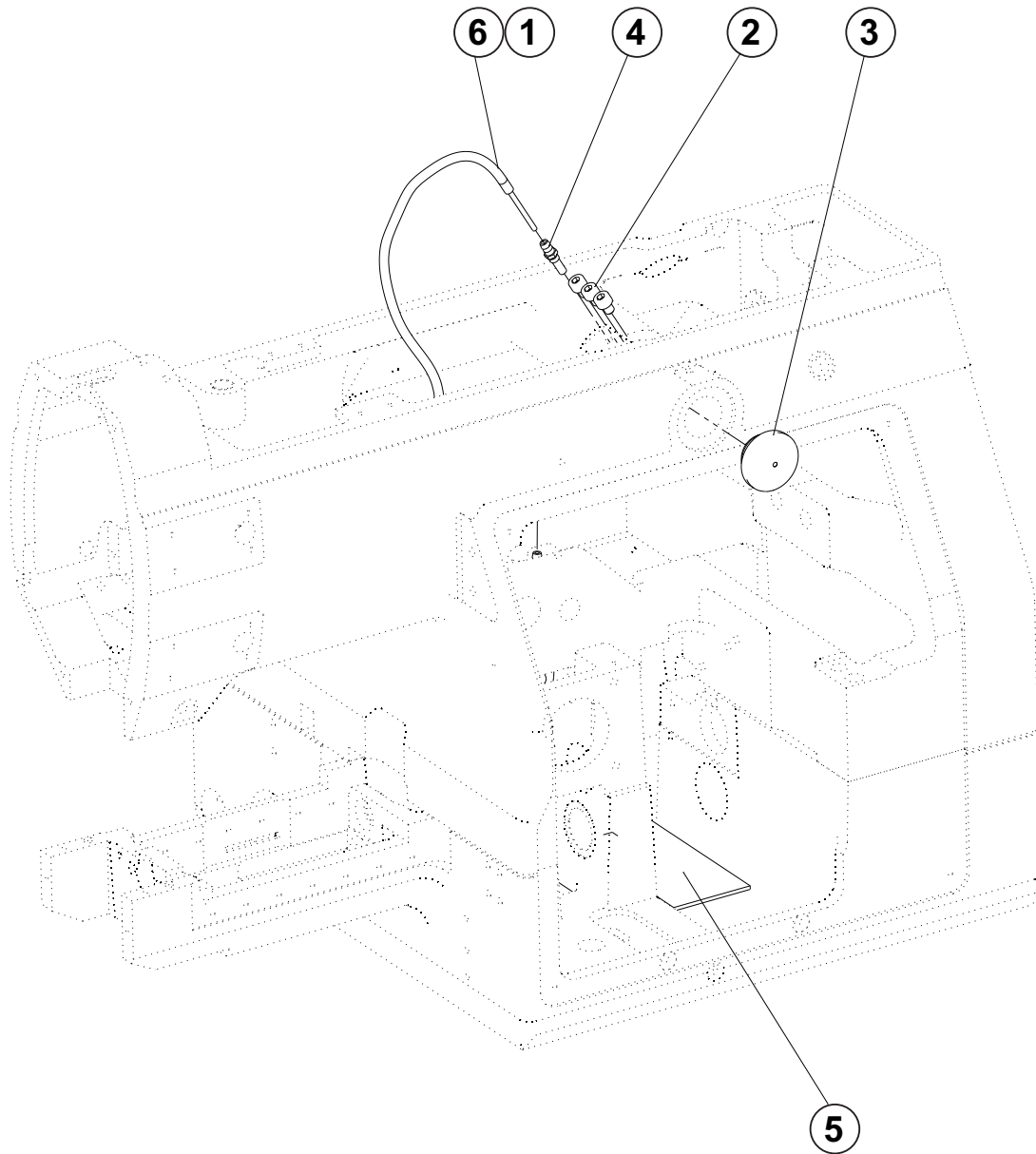

ELECTROBOX

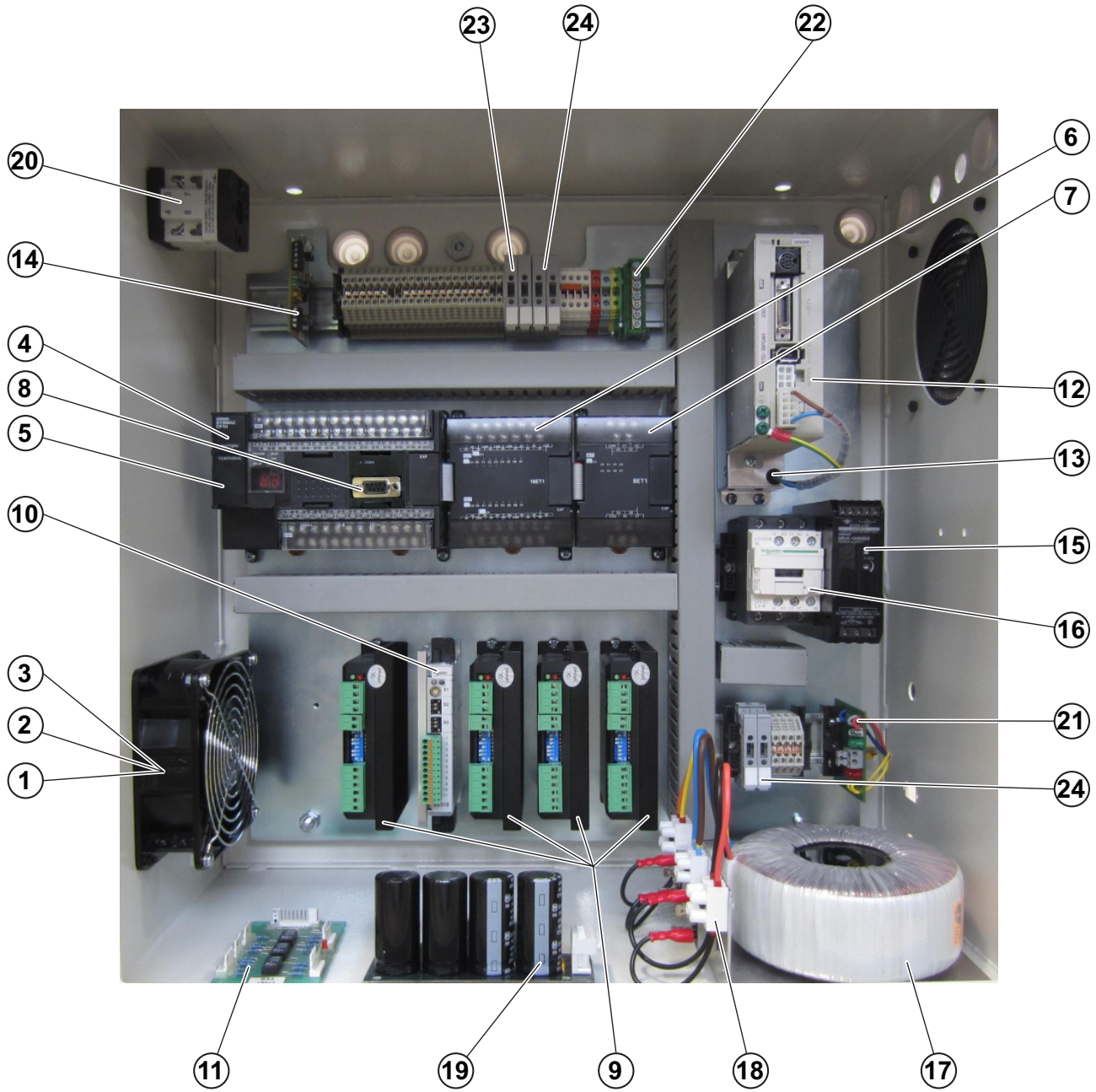

ELECTROBOX

DET	PART NUMBER	DESCRIPTION	QTY.
01	12.0008.4.682	FAN 230V	1
02	12.0008.4.691	SCREEN, FAN	1
03	12.0008.4.761	FAN FILTER 120	1 + 1
04	06.8073.0.001	PLC OMRON CBS	1
05	12.0010.4.163	BATTERY OMRON PLC	1
06	12.0010.4.277	EXP.BLOCK 16 OUT	1
07	12.0010.4.071	EXP.BLOCK 8 OUT	1
08	12.0010.4.067	PORT RS232	1
09	12.0010.4.249	DRIVER 2-PHASE MOTOR	4
10	12.0010.4.161	DRIVER 3-PHASE MOTOR	1
11	12.0010.4.289	BS1 - BOARD SWITCH MOTOR	1
12	06.8073.0.003	SERVODRIVE OMRON CBS	1
13	12.0010.4.251	FILTER	1
14	06.1200.0.010	OB1 - SERVO INTERFACE	1
15	12.0010.4.168	GS1 - POWER 24V	1
16	12.0008.4.833	CONTACTOR 24V	1
17	12.0010.4.007	TOROID TRAF0 2x30V	1
18	12.0008.4.770	RECTIFIER	2
19	12.0010.4.134	CB1 - CAPACITOR BOARD	1
20	12.0010.4.200	MAIN POWER SWITCH	1
21	06.7300.0.061	GS2 - POWER LASER	1
22	12.0008.4.050	BRIDGE GND	1
23	12.0008.4.665	FUSE T2A	2
24	12.0008.4.664	FUSE T10A	2 + 2

ACCESSORIES



ACCESSORIES

DET	PART NUMBER	DESCRIPTION	QTY.
01	02.0332.0.111	NEEDLE STANDARD	10
02	02.1332.0.111	NEEDLE LONG	10
03	12.0008.6.200	NEEDLE THREADER	1
04	12.0008.6.005	SCREW DRIVER	1
05	12.0008.6.001	SCREW DRIVER	1
06	12.0008.6.108	FORK SPANNER	1
07	12.0008.6.109	FORK SPANNER	1
08	12.0008.6.111	FORK SPANNER	1
09	12.0008.6.215	TWEEZERS	1
10	49910018	HOOK	1
11	84.0003.0.390	METRIC ALLEN KEY	1
12	12.0008.6.003	SCREW DRIVER	1
13	05.1322.0.000	OIL CAN	1

ACCESSORIES

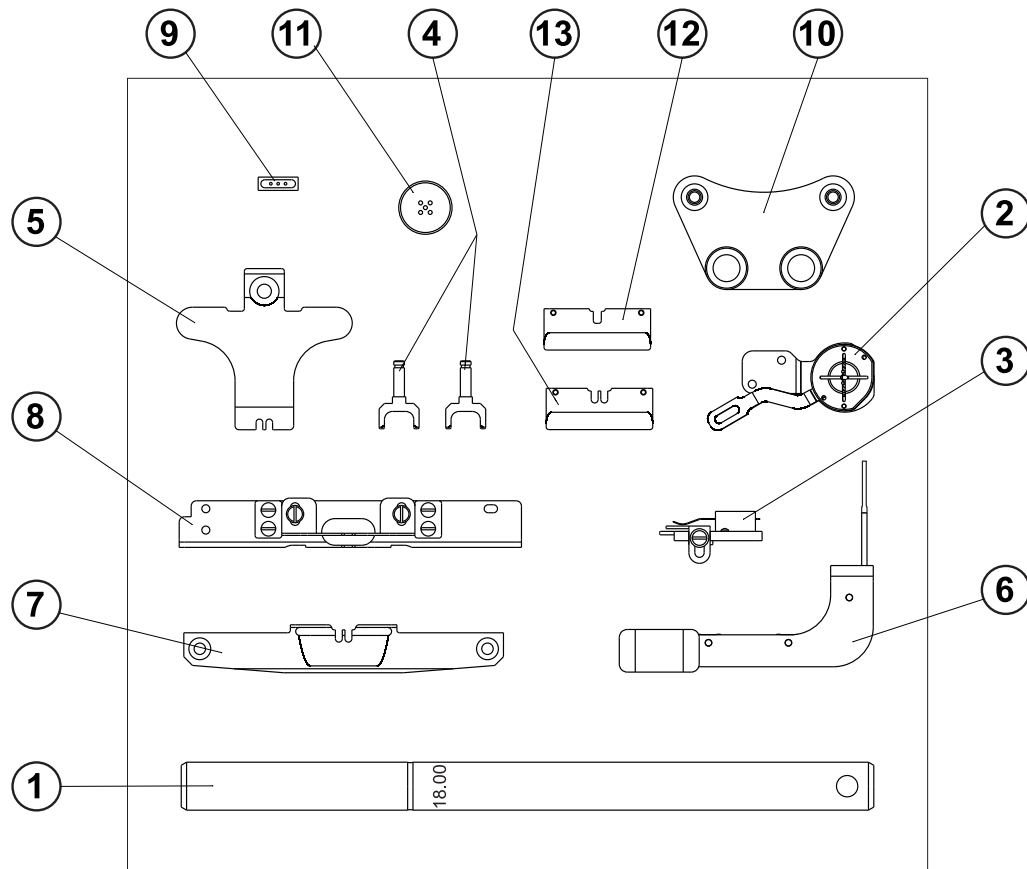

HAND BUTTON FEEDING

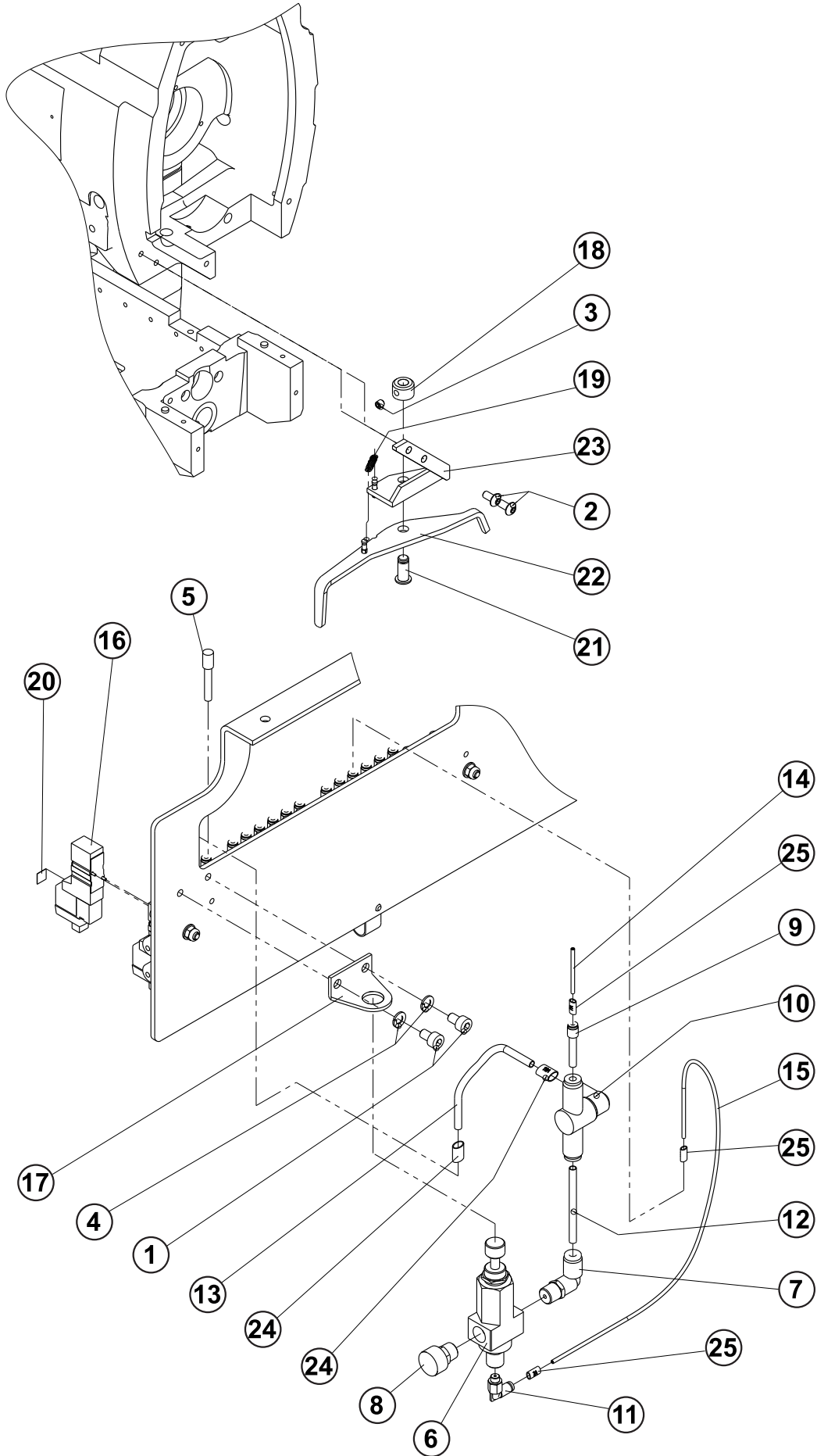

HAND BUTTON FEEDING

DET	PART NUMBER	DESCRIPTION	QTY.
01	08.6002.5.008	SCREW M5-8	2
02	08.6202.4.008	SCREW M4-8	2
03	08.6410.4.004	SCREW M4-4	1
04	08.6802.5.000	SPRING WASHER M5	2
05	12.0008.3.426	PLUG	1
06	12.0008.3.615	REGULATOR	1
07	12.0008.3.640	CONNECTOR	1
08	12.0008.3.785	GAUGE	1
09	12.0008.3.861	CONNECTOR	1
10	12.0008.3.899	LOGIC VALVE	1
11	12.0010.3.064	CONNECTOR	1
12	12.0010.3.080	AIR TUBE- J7A	
13	12.0010.3.080	AIR TUBE- J19A	
14	12.0010.3.103	AIR TUBING - J7A	
15	12.0010.3.103	AIR TUBING - J7A	
16	12.0010.3.105	5/2 VALVE	1
17	12.0010.3.225	BRACKET	1
18	12.1050.0.002	CLAMP COLLAR 6	1
19	12.3011.0.017	SPRING	1
20	12.8000.0.446	LABEL - VALVES 1-30	1
21	17.0032.0.264	STUD	1
22	73.0330.0.800	LEVER	1
23	73.0331.0.600	BRACKET	1
24	94.0093.9.077	TUBE MARKER 19A	2
25	94.0093.9.079	TUBE MARKER 7A	3

EXTENDED TONGUE

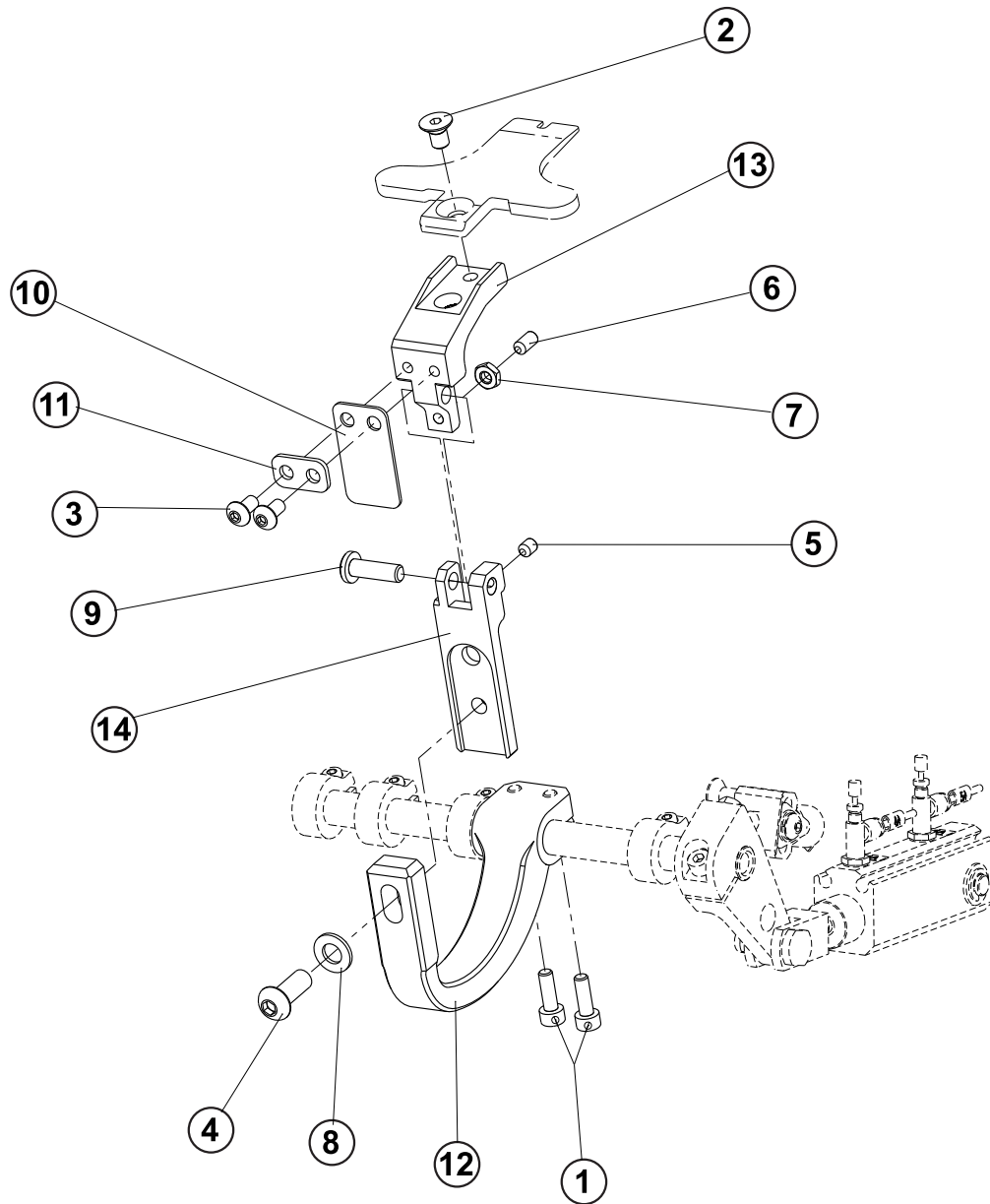

INDEX

PART NUMBER	PAGE	DET	QTY	PART NUMBER	PAGE	DET	QTY	PART NUMBER	PAGE	DET	QTY
32221007	3-25	61	1	08.6000.3.010	3-19	3	6	08.6002.4.012	3-3	26	(1)
49910018	3-79	10	1	08.6000.3.022	3-47	2	2	08.6002.4.012	3-7	2	4
01.2193.0.000	3-19	34	(1)	08.6000.3.025	3-61	1	1	08.6002.4.012	3-11	1	2
01.5167.0.000	3-19	1	1	08.6000.4.005	3-67	1	3	08.6002.4.012	3-17	2	1
01.7804.0.000	3-15	1	1	08.6000.6.030	3-19	4	1	08.6002.4.012	3-23	7	2
02.0332.0.110	3-19	02-1	1	08.6000.8.065	3-57	1	1	08.6002.4.012	3-27	2	2
02.0332.0.111	3-19	02-2	0	08.6000.8.110	3-57	2	1	08.6002.4.012	3-29	3	4
02.0332.0.111	3-79	1	10	08.6002.0.010	3-31	1	14	08.6002.4.012	3-35	2	3
02.0332.0.112	3-19	02-3	0	08.6002.3.006	3-23	2	5	08.6002.4.012	3-37	2	2
02.1332.0.111	3-19	02-4	0	08.6002.3.006	3-31	2	31	08.6002.4.012	3-39	4	1
02.1332.0.111	3-79	2	10	08.6002.3.006	3-39	1	4	08.6002.4.012	3-67	5	4
04.9015.0.000	3-51	1	1	08.6002.3.006	3-43	1	2	08.6002.4.012	3-85	1	2
04.9015.0.361	3-53	1	1	08.6002.3.006	3-45	1	2	08.6002.4.014	3-17	3	2
04.9015.0.362	3-51	2	8	08.6002.3.006	3-51	10	2	08.6002.4.014	3-21	4	1
04.9073.0.361	3-51	3	1	08.6002.3.006	3-59	1	1	08.6002.4.014	3-29	4	2
04.9073.0.362	3-51	4	1	08.6002.3.006	3-67	2	3	08.6002.4.014	3-31	4	2
04.9073.0.363	3-51	5	1	08.6002.3.008	3-9	12	2	08.6002.4.016	3-5	1	4
04.9073.0.900	3-51	6	1	08.6002.3.008	3-23	3	4	08.6002.4.016	3-13	1	1
04.9073.0.901	3-51	7	1	08.6002.3.008	3-29	1	1	08.6002.4.016	3-23	8	4
05.1322.0.000	3-51	8	1	08.6002.3.008	3-35	1	4	08.6002.4.016	3-37	3	1
05.1322.0.000	3-79	13	1	08.6002.3.008	3-37	35	(4)	08.6002.4.016	3-59	3	2
06.1200.0.010	3-77	14	1	08.6002.3.008	3-41	1	1	08.6002.4.022	3-7	3	2
06.7300.0.007	3-51	9	1	08.6002.3.008	3-47	3	1	08.6002.4.025	3-23	9	4
06.7300.0.021	3-23	1	1	08.6002.3.010	3-3	1	2	08.6002.4.025	3-31	5	2
06.7300.0.022	3-27	1	1	08.6002.3.010	3-23	4	5	08.6002.4.025	3-47	6	2
06.7300.0.023	3-21	1	1	08.6002.3.010	3-39	2	4	08.6002.4.030	3-33	1	2
06.7300.0.024	3-7	1	1	08.6002.3.010	3-41	2	1	08.6002.4.030	3-55	4	2
06.7300.0.025	3-47	1	1	08.6002.3.010	3-67	3	3	08.6002.5.006	3-75	2	3
06.7300.0.042	3-31	26	1	08.6002.3.012	3-23	5	4	08.6002.5.008	3-15	23	(1)
06.7300.0.043	3-21	2	1	08.6002.3.012	3-67	4	2	08.6002.5.008	3-67	6	4
06.7300.0.044	3-31	27	1	08.6002.3.014	3-9	13	2	08.6002.5.008	3-83	1	2
06.7300.0.047	3-37	1	1	08.6002.3.016	3-43	2	2	08.6002.5.010	3-11	2	3
06.7300.0.050	3-13	26	1	08.6002.3.016	3-45	2	2	08.6002.5.010	3-17	4	1
06.7300.0.053	3-49	20	(1)	08.6002.3.018	3-41	3	1	08.6002.5.012	3-15	38	2
06.7300.0.054	3-49	23	(1)	08.6002.3.025	3-47	4	4	08.6002.5.012	3-23	10	2
06.7300.0.055	3-55	1	1	08.6002.3.030	3-23	6	2	08.6002.5.012	3-27	3	1
06.7300.0.056	3-53	2	1	08.6002.4.006	3-31	3	2	08.6002.5.012	3-33	2	1
06.7300.0.061	3-77	21	1	08.6002.4.008	3-29	2	2	08.6002.5.012	3-67	7	10
06.8073.0.001	3-77	4	1	08.6002.4.008	3-41	4	1	08.6002.5.016	3-3	22	(1)
06.8073.0.003	3-77	12	1	08.6002.4.008	3-47	5	2	08.6002.5.016	3-7	4	2
07.0400.0.000	3-75	1	1	08.6002.4.010	3-21	3	10	08.6002.5.016	3-23	11	1
07.6440.0.014	3-17	1	1	08.6002.4.010	3-39	3	2	08.6002.5.016	3-27	4	4
07.6600.0.004	3-55	2	2	08.6002.4.010	3-43	3	2	08.6002.5.016	3-59	4	3
07.6600.0.006	3-55	3	1	08.6002.4.010	3-45	3	2	08.6002.5.016	3-63	1	1
08.6000.3.006	3-49	26	(8)	08.6002.4.010	3-59	2	2	08.6002.5.018	3-15	25	(1)

INDEX

PART NUMBER	PAGE	DET	QTY	PART NUMBER	PAGE	DET	QTY	PART NUMBER	PAGE	DET	QTY
08.6002.5.020	3-5	2	2+(1)	08.6112.2.006	3-69	1	(2)	08.6400.5.008	3-5	28	3
08.6002.5.020	3-13	2	2	08.6112.2.006	3-71	1	(2)	08.6400.5.008	3-7	7	2
08.6002.5.020	3-15	24	(1)	08.6112.3.005	3-33	4	2	08.6400.5.008	3-11	8	2
08.6002.5.020	3-23	12	1	08.6112.3.006	3-41	6	8	08.6400.5.008	3-15	20	2
08.6002.5.020	3-31	6	2	08.6117.2.004	3-33	5	4	08.6400.5.008	3-19	8	1
08.6002.5.022	3-23	13	2	08.6200.3.005	3-63	2	1	08.6400.5.010	3-13	23	(2)
08.6002.5.025	3-15	22	(2)	08.6200.4.006	3-15	33	2	08.6400.5.010	3-17	13	(4)
08.6002.5.025	3-21	5	1	08.6202.3.006	3-31	7	2	08.6400.5.010	3-19	9	1
08.6002.5.025	3-23	14	4	08.6202.3.006	3-41	7	1	08.6400.5.010	3-67	12	1
08.6002.5.030	3-13	3	1	08.6202.3.006	3-57	34	2	08.6400.5.305	3-15	3	(2)
08.6002.5.035	3-47	7	1	08.6202.3.010	3-63	3	2	08.6400.5.305	3-17	15	(2)
08.6002.5.040	3-7	5	1	08.6202.4.006	3-23	17	4	08.6400.6.008	3-5	4	1
08.6002.5.040	3-47	8	4	08.6202.4.008	3-29	6	2	08.6400.6.010	3-13	24	(2)
08.6002.5.050	3-11	3	2	08.6202.4.008	3-37	6	4	08.6400.6.030	3-11	9	1
08.6002.5.055	3-49	1	1	08.6202.4.008	3-83	2	2	08.6402.3.010	3-59	5	1
08.6002.6.010	3-15	26	2	08.6202.4.008	3-85	3	2	08.6402.4.005	3-37	7	1
08.6002.6.016	3-49	2	2	08.6202.4.010	3-41	8	4	08.6402.4.005	3-85	5	1
08.6002.6.020	3-15	2	2	08.6202.4.010	3-51	47	4	08.6402.4.008	3-15	21	(2)
08.6002.6.020	3-23	15	2	08.6202.5.008	3-49	5	2	08.6402.4.008	3-37	8	1
08.6002.8.012	3-51	11	2	08.6202.6.016	3-37	19	1	08.6402.4.008	3-85	6	1
08.6002.8.020	3-49	3	1	08.6202.6.016	3-85	4	1	08.6402.6.008	3-51	15	2
08.6002.8.025	3-57	3	2	08.6310.3.012	3-47	9	1	08.6402.6.012	3-57	4	2
08.6002.8.045	3-51	12	4	08.6310.4.016	3-29	7	2	08.6410.3.003	3-11	4	1
08.6002.8.065	3-51	13	1	08.6312.4.010	3-23	18	2	08.6410.4.004	3-3	2	2
08.6012.3.003	3-39	5	(3)+(3)	08.6312.4.010	3-33	6	1	08.6410.4.004	3-63	4	2
08.6012.3.004	3-65	1	4	08.6312.6.040	3-5	3	1	08.6410.4.004	3-83	3	1
08.6012.3.006	3-9	14	1	08.6400.3.004	3-35	12	(6)	08.6410.4.005	3-3	3	2
08.6012.3.006	3-29	5	4	08.6400.4.004	3-11	5	2	08.6410.4.005	3-31	8	2
08.6012.3.006	3-73	5	(2)	08.6400.4.004	3-67	9	4	08.6410.5.005	3-3	21	(2)+(1)
08.6012.3.012	3-9	15	1	08.6400.4.005	3-3	25	(1)	08.6410.5.005	3-7	8	1
08.6012.3.016	3-7	6	2	08.6400.4.005	3-11	6	3	08.6410.5.005	3-13	25	(2)
08.6012.3.018	3-41	5	2	08.6400.4.005	3-19	6	2	08.6410.5.005	3-17	5	2
08.6012.4.008	3-67	8	1	08.6400.4.005	3-23	19	4	08.6410.5.005	3-47	10	1
08.6012.4.016	3-33	3	2	08.6400.5.005	3-5	27	(1)	08.6410.5.008	3-5	25	1+(1)+(1)+(1)
08.6032.3.005	3-55	5	8	08.6400.5.005	3-11	7	1	08.6410.5.008	3-7	9	2
08.6032.4.008	3-23	16	3	08.6400.5.005	3-17	14	2	08.6410.5.008	3-27	11	(2)
08.6032.4.008	3-55	6	3	08.6400.5.005	3-19	7	3	08.6646.4.050	3-51	16	3
08.6032.4.010	3-49	4	3	08.6400.5.005	3-21	6	2	08.6663.5.025	3-51	17	13
08.6100.3.008	3-53	3	2	08.6400.5.005	3-23	20	2	08.6676.3.020	3-51	18	22
08.6102.4.008	3-19	5	2	08.6400.5.005	3-67	10	1	08.6700.4.000	3-37	9	1
08.6102.5.008	3-37	4	1	08.6400.5.006	3-3	24	(2)	08.6702.0.000	3-51	19	8
08.6102.5.008	3-85	2	1	08.6400.5.006	3-5	24	(1)	08.6702.3.000	3-47	11	2
08.6102.5.010	3-51	14	2	08.6400.5.006	3-41	9	1	08.6702.3.000	3-55	7	4
08.6102.5.016	3-37	5	2	08.6400.5.006	3-67	11	1	08.6702.4.000	3-23	21	4
08.6110.4.010	3-13	4	4	08.6400.5.008	3-3	23	(2)	08.6702.4.000	3-47	12	2

INDEX

PART NUMBER	PAGE	DET	QTY	PART NUMBER	PAGE	DET	QTY	PART NUMBER	PAGE	DET	QTY
08.6702.4.000	3-51	45	4	08.6802.5.000	3-83	4	2	08.6852.6.000	3-85	8	1
08.6702.5.000	3-7	10	1	08.6802.6.000	3-15	27	2	08.6852.8.000	3-59	14	1
08.6702.5.000	3-27	5	1	08.6802.6.000	3-23	24	2	08.6882.5.000	3-49	10	2
08.6702.5.000	3-47	13	2	08.6802.6.000	3-49	8	2	08.6882.8.000	3-49	11	1
08.6702.6.000	3-5	5	1	08.6802.8.000	3-49	9	1	08.6887.3.001	3-19	28	(2)+(2)
08.6702.8.000	3-57	5	2	08.6802.8.000	3-51	22	5	08.6890.0.000	3-13	9	1
08.6710.4.000	3-37	10	3	08.6807.3.100	3-61	2	2	12.0008.3.413	3-47	17	2
08.6710.4.000	3-85	7	1	08.6832.4.000	3-55	9	3	12.0008.3.416	3-9	21	1
08.6712.4.000	3-29	8	2	08.6842.4.000	3-55	10	3	12.0008.3.416	3-11	14	1
08.6712.4.000	3-63	5	3	08.6850.0.000	3-15	30	3	12.0008.3.416	3-31	10	1
08.6712.6.000	3-11	10	2	08.6850.6.000	3-15	28	2	12.0008.3.416	3-67	16	1
08.6712.6.000	3-35	3	2	08.6852.0.000	3-13	7	1	12.0008.3.426	3-55	13	8
08.6712.6.000	3-63	6	1	08.6852.0.000	3-51	23	8	12.0008.3.426	3-83	5	1
08.6722.4.000	3-41	10	2	08.6852.3.000	3-9	17	2	12.0008.3.451	3-55	14	1
08.6732.4.000	3-37	36	1	08.6852.3.000	3-41	12	4	12.0008.3.615	3-83	6	1
08.6732.4.000	3-55	8	2	08.6852.3.000	3-55	11	4	12.0008.3.640	3-83	7	1
08.6732.5.000	3-11	11	1	08.6852.3.000	3-59	11	1	12.0008.3.700	3-11	15	2
08.6732.5.000	3-49	6	1	08.6852.3.000	3-63	7	2	12.0008.3.738	3-43	5	1
08.6732.6.000	3-11	12	1	08.6852.3.000	3-67	13	3	12.0008.3.738	3-45	5	1
08.6733.3.000	3-59	6	1	08.6852.3.000	3-73	6	(2)	12.0008.3.739	3-37	11	1
08.6733.8.000	3-59	7	1	08.6852.4.000	3-7	12	4	12.0008.3.749	3-23	28	1
08.6752.8.000	3-51	20	2	08.6852.4.000	3-13	8	1	12.0008.3.749	3-23	29	1
08.6792.0.300	3-13	5	1	08.6852.4.000	3-21	8	5	12.0008.3.749	3-39	21	1
08.6802.0.000	3-51	21	4	08.6852.4.000	3-23	25	5	12.0008.3.749	3-41	14	—
08.6802.3.000	3-29	9	1	08.6852.4.000	3-33	7	1	12.0008.3.749	3-41	15	—
08.6802.3.000	3-41	11	3	08.6852.4.000	3-37	37	1	12.0008.3.749	3-41	16	—
08.6802.3.000	3-59	8	1	08.6852.4.000	3-39	7	1	12.0008.3.749	3-41	17	—
08.6802.4.000	3-5	6	4	08.6852.4.000	3-41	13	1	12.0008.3.749	3-59	15	1,5m
08.6802.4.000	3-7	11	4	08.6852.4.000	3-43	4	2	12.0008.3.749	3-67	17	1
08.6802.4.000	3-9	16	1	08.6852.4.000	3-45	4	2	12.0008.3.785	3-83	8	1
08.6802.4.000	3-13	6	1	08.6852.4.000	3-47	15	6	12.0008.3.790	3-55	15	1
08.6802.4.000	3-21	7	5	08.6852.4.000	3-51	46	4	12.0008.3.798	3-9	8	2
08.6802.4.000	3-23	22	11	08.6852.4.000	3-55	12	2	12.0008.3.810	3-33	8	2
08.6802.4.000	3-27	6	2	08.6852.4.000	3-59	12	2	12.0008.3.810	3-39	8	2
08.6802.4.000	3-31	9	2	08.6852.4.000	3-67	14	1	12.0008.3.815	3-37	12	2
08.6802.4.000	3-39	6	2	08.6852.5.000	3-7	13	2	12.0008.3.826	3-23	30	2
08.6802.4.000	3-47	14	2	08.6852.5.000	3-11	13	1	12.0008.3.826	3-43	6	2
08.6802.4.000	3-51	44	8	08.6852.5.000	3-15	41	2	12.0008.3.826	3-45	6	2
08.6802.4.000	3-59	9	2	08.6852.5.000	3-23	26	6	12.0008.3.861	3-55	16	21
08.6802.5.000	3-3	4	2	08.6852.5.000	3-47	16	3	12.0008.3.861	3-83	9	1
08.6802.5.000	3-15	40	2	08.6852.5.000	3-59	13	2	12.0008.3.899	3-83	10	1
08.6802.5.000	3-23	23	4	08.6852.5.000	3-67	15	14	12.0008.4.050	3-77	22	1
08.6802.5.000	3-27	7	4	08.6852.6.000	3-19	10	1	12.0008.4.146	3-57	6	2
08.6802.5.000	3-49	7	1	08.6852.6.000	3-23	27	2	12.0008.4.214	3-49	25	(2)
08.6802.5.000	3-59	10	2	08.6852.6.000	3-37	39	1	12.0008.4.290	3-55	17	1

INDEX

PART NUMBER	PAGE	DET	QTY	PART NUMBER	PAGE	DET	QTY	PART NUMBER	PAGE	DET	QTY
12.0008.4.664	3-77	24	2 + 2	12.0010.3.103	3-39	22	1	12.0010.4.177	3-5	7	1
12.0008.4.665	3-77	23	2	12.0010.3.103	3-39	31	(1)	12.0010.4.200	3-77	20	1
12.0008.4.682	3-77	1	1	12.0010.3.103	3-41	20	—	12.0010.4.249	3-77	9	4
12.0008.4.691	3-77	2	1	12.0010.3.103	3-41	21	—	12.0010.4.251	3-77	13	1
12.0008.4.761	3-77	3	1 + 1	12.0010.3.103	3-41	22	—	12.0010.4.277	3-77	6	1
12.0008.4.770	3-77	18	2	12.0010.3.103	3-41	23	—	12.0010.4.289	3-77	11	1
12.0008.4.833	3-77	16	1	12.0010.3.103	3-47	20	1	12.0010.4.300	3-49	12	1
12.0008.6.001	3-79	5	1	12.0010.3.103	3-47	21	1	12.0010.4.303	3-55	21	4
12.0008.6.003	3-79	12	1	12.0010.3.103	3-47	22	1	12.0010.4.310	3-57	9	1
12.0008.6.005	3-79	4	1	12.0010.3.103	3-59	17	1,5m	12.0010.4.311	3-63	8	1
12.0008.6.108	3-79	6	1	12.0010.3.103	3-67	21	1	12.0010.4.321	3-57	10	1
12.0008.6.109	3-79	7	1	12.0010.3.103	3-83	14	0	12.0010.6.210	3-33	12	1
12.0008.6.111	3-79	8	1	12.0010.3.103	3-83	15	0	12.0010.6.906	3-57	11	3
12.0008.6.200	3-79	3	1	12.0010.3.105	3-55	19	19	12.0010.6.916	3-57	12	1
12.0008.6.215	3-79	9	1	12.0010.3.105	3-83	16	1	12.1010.0.412	3-23	36	1
12.0008.6.530	3-57	7	1	12.0010.3.106	3-55	20	1	12.1010.0.620	3-11	19	2
12.0008.6.812	3-51	24	1	12.0010.3.123	3-37	15	1	12.1010.2.001	3-35	4	2
12.0008.6.820	3-57	8	2	12.0010.3.124	3-43	7	1	12.1010.2.013	3-3	20	(1)
12.0008.6.821	3-51	25	2	12.0010.3.124	3-45	7	1	12.1010.2.013	3-5	26	(1)
12.0008.6.824	3-15	36	4	12.0010.3.125	3-41	24	1	12.1010.2.024	3-11	20	1
12.0010.3.028	3-11	16	2	12.0010.3.126	3-47	23	1	12.1010.2.030	3-11	21	1
12.0010.3.047	3-31	11	2	12.0010.3.128	3-59	18	1	12.1010.3.001	3-57	13	2
12.0010.3.047	3-67	18	2	12.0010.3.130	3-67	22	1	12.1014.0.002	3-7	14	2
12.0010.3.064	3-23	31	2	12.0010.3.132	3-9	19	2	12.1014.0.308	3-41	25	2
12.0010.3.064	3-67	19	2	12.0010.3.134	3-9	9	1	12.1016.0.002	3-57	14	4
12.0010.3.064	3-83	11	1	12.0010.3.145	3-11	18	1	12.1016.1.000	3-51	26	8
12.0010.3.065	3-41	18	2	12.0010.3.158	3-31	13	1	12.1045.0.001	3-47	25	2
12.0010.3.070	3-47	18	2	12.0010.3.184	3-39	9	1	12.1045.0.004	3-11	22	2
12.0010.3.070	3-59	16	2	12.0010.3.186	3-39	20	1	12.1045.0.004	3-31	15	2
12.0010.3.071	3-47	19	1	12.0010.3.190	3-33	11	1	12.1045.0.004	3-33	13	1
12.0010.3.072	3-41	19	2	12.0010.3.192	3-67	23	2	12.1045.0.004	3-37	16	1
12.0010.3.080	3-9	20	1	12.0010.3.193	3-23	34	1	12.1045.0.004	3-41	26	8
12.0010.3.080	3-11	17	1	12.0010.3.225	3-83	17	1	12.1045.0.007	3-15	32	6
12.0010.3.080	3-31	12	1	12.0010.4.007	3-77	17	1	12.1045.0.007	3-43	8	1
12.0010.3.080	3-39	23	1	12.0010.4.067	3-77	8	1	12.1045.0.007	3-45	8	1
12.0010.3.080	3-67	20	1	12.0010.4.071	3-77	7	1	12.1045.0.009	3-13	11	2
12.0010.3.080	3-83	12	0	12.0010.4.093	3-13	10	1	12.1050.0.002	3-3	5	2
12.0010.3.080	3-83	13	0	12.0010.4.093	3-21	9	1	12.1050.0.002	3-11	23	1
12.0010.3.099	3-55	18	2	12.0010.4.093	3-23	35	1	12.1050.0.002	3-83	18	1
12.0010.3.103	3-23	32	1	12.0010.4.093	3-31	14	2	12.1050.0.005	3-7	15	1
12.0010.3.103	3-23	33	1	12.0010.4.093	3-47	24	1	12.2010.0.000	3-7	16	1
12.0010.3.103	3-33	9	1	12.0010.4.134	3-77	19	1	12.2010.0.004	3-5	8	1
12.0010.3.103	3-33	10	1	12.0010.4.161	3-77	10	1	12.2010.0.004	3-15	29	6
12.0010.3.103	3-37	13	1	12.0010.4.163	3-77	5	1	12.2010.0.007	3-7	17	1
12.0010.3.103	3-37	14	1	12.0010.4.168	3-77	15	1	12.2010.0.010	3-5	9	1

INDEX

PART NUMBER	PAGE	DET	QTY	PART NUMBER	PAGE	DET	QTY	PART NUMBER	PAGE	DET	QTY
12.2010.0.010	3-15	4	1	15.1427.0.100	3-63	9	4	68.0159.0.300	3-63	11	1
12.2010.0.011	3-7	18	1	15.1436.0.100	3-15	8	3	68.0356.1.300	3-49	14	1
12.2010.0.038	3-3	6	2	15.1436.0.100	3-47	26	4	68.0357.0.800	3-49	15	1
12.2010.0.039	3-19	29	(1)+(1)	15.1436.0.100	3-49	19	(8)	68.0358.0.800	3-49	16	1
12.2010.0.040	3-13	12	1	15.3206.0.300	3-47	27	2	71.1143.1.086	3-81	11	1
12.2010.0.041	3-13	13	1	15.4431.0.400	3-11	24-1	1	71.1570.0.037	3-51	35	1
12.2050.0.013	3-5	10	2	15.4432.0.400	3-11	24-2	0	71.1664.1.087	3-37	22	1
12.2050.0.014	3-15	35	4	15.4433.0.400	3-11	24-3	0	71.1664.1.087	3-85	9	1
12.2060.0.007	3-35	5	2	15.4434.0.400	3-11	24-4	0	71.1664.1.088	3-85	10	1
12.2070.0.020	3-23	37	2	15.4609.0.300	3-67	24	1	71.1664.1.093	3-37	24	1
12.2070.1.015	3-39	10	1	15.6005.0.990	3-51	29	4	71.1664.1.093	3-85	11	1
12.2070.1.047	3-31	16	3	17.0019.0.441	3-51	30	5	71.1664.2.088	3-37	23	1
12.2070.1.050	3-23	38	1	17.0026.0.222	3-47	28	1	71.1665.1.017	3-37	25	1
12.2070.1.055	3-23	39	1	17.0027.1.419	3-19	11	1	71.1665.1.019	3-37	26	1
12.2099.2.001	3-3	7	2	17.0027.4.085	3-15	42	1	71.1665.1.020	3-37	27	1
12.3011.0.017	3-83	19	1	17.0032.0.193	3-67	25	1	71.1665.1.021	3-37	28	1
12.3013.0.002	3-61	3	1	17.0032.0.264	3-83	21	1	71.1665.1.022	3-37	29	1
12.3015.2.005	3-39	13	(1)	17.0041.8.003	3-67	26	1	73.0001.0.500	3-13	15	1
12.3015.2.005	3-39	27	(1)	17.0043.6.018	3-15	9	1	73.0002.1.300	3-11	26	1
12.4030.0.412	3-15	5	1	17.0043.6.018	3-17	6	1	73.0003.0.300	3-11	27	1
12.4030.0.430	3-5	11	1	17.0082.8.017	3-19	12	2	73.0004.0.600	3-11	28	1
12.5050.2.035	3-5	12	1	17.0082.8.082	3-47	29	3	73.0005.0.300	3-11	29	1
12.5050.2.036	3-7	19	1	17.0094.0.029	3-53	4	8	73.0006.0.300	3-13	16	1
12.5050.2.037	3-5	13	1	17.0094.0.200	3-51	31	4	73.0007.0.600	3-11	30	1
12.5050.2.038	3-15	6	1	17.0095.1.272	3-51	32	5	73.0008.0.300	3-11	31	1
12.8000.0.437	3-57	15	1	17.0095.1.329	3-75	3	1	73.0009.0.600	3-11	32	1
12.8000.0.445	3-57	16	1	17.0097.5.174	3-57	22	3	73.0010.0.300	3-11	33	1
12.8000.0.446	3-83	20	1	19.0014.7.003	3-51	33	2	73.0011.0.100	3-11	34	1
12.8000.1.039	3-57	17	1	19.0016.3.406	3-37	18	1	73.0012.0.300	3-11	35	1
12.8000.1.050	3-57	18	1	19.0031.8.412	3-47	30	1	73.0013.0.100	3-11	36	1
12.9900.9.005	3-51	27	1	19.0044.1.623	3-11	25	1	73.0014.0.600	3-11	37	1
12.9900.9.007	3-9	10	1	19.0044.5.404	3-51	34	1	73.0015.0.050	3-19	14	2
12.9900.9.008	3-9	11	1	22.0229.0.000	3-75	4	1	73.0015.0.050	3-63	12	2
15.1106.0.400	3-15	31	2	24.0061.0.000	3-9	7	1	73.0016.0.800	3-19	31	(1)+(1)
15.1128.0.000	3-15	39	1	24.0061.0.000	3-43	9	2	73.0017.0.800	3-19	32	(1)+(1)
15.1128.0.050	3-13	14	1	24.0061.0.000	3-45	9	2	73.0018.0.400	3-19	30	(1)+(1)
15.1138.0.800	3-15	7	1	24.0100.0.000	3-19	13	1	73.0019.0.600	3-63	13	1
15.1145.0.800	3-51	28	1	24.0119.0.050	3-47	31	3	73.0020.0.600	3-63	14	1
15.1405.0.000	3-49	24	(1)	24.0168.0.000	3-49	13	3	73.0021.0.600	3-11	38	1
15.1410.0.992	3-61	4	1	24.2076.0.000	3-39	11	(1)	73.0022.0.400	3-13	17	1
15.1416.0.902	3-61	5	1	24.2076.0.000	3-39	28	(1)	73.0023.0.600	3-13	18	1
15.1420.0.100	3-57	19	14	24.4075.0.000	3-21	10	1	73.0024.0.500	3-13	19	1
15.1422.0.100	3-61	6	2	24.4075.0.000	3-23	40	1	73.0025.0.600	3-13	20	1
15.1425.0.100	3-57	20	3	50.0046.0.800	3-47	32	1	73.0026.0.600	3-13	21	1
15.1427.0.100	3-57	21	2	68.0158.0.600	3-63	10	1	73.0027.0.600	3-13	22	1

INDEX

PART NUMBER	PAGE	DET	QTY	PART NUMBER	PAGE	DET	QTY	PART NUMBER	PAGE	DET	QTY
73.0028.0.500	3-27	8	1	73.0083.0.800	3-51	38	1	73.0129.0.600	3-5	19	1
73.0029.0.300	3-27	9	1	73.0084.0.800	3-47	39	1	73.0130.0.300	3-3	13	1
73.0030.0.800	3-27	10	1	73.0084.0.800	3-51	39	1	73.0131.0.800	3-63	17	1
73.0031.0.100	3-61	7	1	73.0085.0.000	3-49	21	(1)	73.0132.0.600	3-67	28	1
73.0032.0.600	3-61	8	1	73.0085.0.050	3-49	18	1	73.0133.1.800	3-67	29	1
73.0033.0.600	3-9	1	1	73.0086.0.050	3-49	22	1	73.0134.0.600	3-67	30	1
73.0034.0.600	3-19	15	1	73.0087.0.800	3-49	17	1	73.0135.0.300	3-67	31	2
73.0035.0.600	3-19	16	1	73.0088.0.600	3-9	4	1	73.0136.0.600	3-67	32	1
73.0036.0.300	3-19	17	1	73.0089.0.600	3-9	3	1	73.0137.0.800	3-67	33	1
73.0037.0.600	3-19	18	1	73.0090.0.600	3-9	2	1	73.0138.1.400	3-67	34	1
73.0039.0.600	3-19	19	2	73.0091.0.300	3-57	25	2	73.0139.0.600	3-67	35	1
73.0040.0.600	3-19	20	1	73.0093.0.992	3-57	27	1	73.0141.0.600	3-67	36	1
73.0041.0.100	3-19	21	1	73.0095.0.000	3-23	41	1	73.0142.0.000	3-67	37	1
73.0042.0.100	3-63	15	1	73.0096.0.600	3-23	42	1	73.0144.0.600	3-67	38	1
73.0043.0.300	3-19	22	1	73.0097.0.600	3-23	43	1	73.0145.0.050	3-41	32	1
73.0044.0.300	3-19	23	1	73.0098.0.600	3-23	44	1	73.0146.0.800	3-41	33	1
73.0045.0.400	3-19	24	1	73.0099.0.400	3-23	45	1	73.0147.0.600	3-41	34	4
73.0046.0.300	3-19	25	1	73.0100.0.800	3-23	46	1	73.0148.0.300	3-41	35	2
73.0047.0.300	3-19	26	1	73.0101.0.300	3-25	47	1	73.0149.0.600	3-41	36	1
73.0048.0.600	3-19	27	1	73.0102.0.600	3-25	48	1	73.0150.0.800	3-41	37	1
73.0050.0.600	3-3	8	1	73.0103.0.600	3-25	49	1	73.0151.0.600	3-41	38	1
73.0051.0.800	3-63	16	1	73.0104.0.800	3-25	50	1	73.0152.0.600	3-41	39	1
73.0052.0.600	3-11	39	1	73.0105.0.300	3-25	51	1	73.0153.0.800	3-41	40	2
73.0054.0.700	3-57	23	1	73.0106.0.800	3-21	11	1	73.0154.0.300	3-41	41	1
73.0060.0.700	3-57	24	1	73.0107.0.600	3-21	12	1	73.0155.0.600	3-41	42	1
73.0062.0.600	3-47	33	1	73.0108.0.600	3-21	13	1	73.0157.0.800	3-57	28	1
73.0063.0.600	3-47	34	1	73.0109.0.600	3-21	14	1	73.0158.0.800	3-57	29	1
73.0064.0.300	3-47	35	2	73.0110.0.300	3-21	15	1	73.0159.0.800	3-57	30	1
73.0065.0.800	3-47	36	1	73.0111.0.600	3-25	52	2	73.0160.0.800	3-57	31	1
73.0066.0.800	3-47	37	1	73.0112.0.600	3-25	53	1	73.0162.0.600	3-45	11	1
73.0067.0.300	3-47	38	2	73.0113.0.800	3-21	16	1	73.0163.0.600	3-43	11	1
73.0068.0.300	3-41	27	2	73.0114.0.400	3-25	54	1	73.0164.0.600	3-45	12	1
73.0069.0.800	3-43	10	1	73.0116.0.000	3-3	9	1	73.0165.0.600	3-43	12	1
73.0069.0.800	3-45	10	1	73.0118.0.992	3-7	20	1	73.0167.0.800	3-43	13	1
73.0070.0.300	3-41	28	1	73.0119.0.300	3-7	21	1	73.0167.0.800	3-45	13	1
73.0070.0.300	3-67	27	1	73.0120.0.500	3-5	14	1	73.0168.0.800	3-43	14	1
73.0071.0.800	3-41	29	1	73.0120.0.500	3-7	22	1	73.0168.0.800	3-45	14	1
73.0072.0.300	3-41	30	2	73.0122.0.050	3-5	15	1	73.0169.0.100	3-43	15	1
73.0073.0.300	3-41	31	1	73.0123.0.050	3-3	10	1	73.0169.0.100	3-45	15	1
73.0077.0.800	3-59	19	1	73.0124.0.300	3-5	16	1	73.0172.0.400	3-3	14	2
73.0078.0.300	3-59	20	1	73.0125.0.500	3-5	17	1	73.0173.0.400	3-3	15	1
73.0079.0.600	3-51	36	1	73.0125.0.500	3-15	10	1	73.0174.0.400	3-3	16	1
73.0080.0.990	3-51	37	1	73.0126.0.600	3-3	11	1	73.0175.0.400	3-3	17	1
73.0081.0.800	3-55	22	1	73.0127.0.300	3-5	18	1	73.0176.0.300	3-37	30	1
73.0082.0.800	3-55	23	1	73.0128.0.300	3-3	12	1	73.0177.0.300	3-37	31	1

INDEX

PART NUMBER	PAGE	DET	QTY	PART NUMBER	PAGE	DET	QTY	PART NUMBER	PAGE	DET	QTY
73.0179.0.600	3-37	33	1	73.0234.0.600	3-39	16	1	73.0278.0.600	3-29	16	1
73.0180.0.800	3-3	18	1	73.0235.0.800	3-39	17	1	73.0279.0.800	3-29	17	1
73.0181.0.400	3-3	19	1	73.0236.0.600	3-39	29	(1)	73.0281.0.500	3-17	7	2
73.0182.0.800	3-5	20	1	73.0237.1.800	3-39	26	(1)	73.0283.0.400	3-17	8	1
73.0183.0.500	3-5	21	1	73.0238.0.992	3-39	12	(1)	73.0284.0.500	3-17	9	2
73.0184.0.500	3-5	22	1	73.0239.0.000	3-35	6	1	73.0285.0.300	3-17	10	1
73.0185.0.600	3-5	23	1	73.0240.0.600	3-35	7	1	73.0286.0.400	3-17	11	1
73.0186.0.300	3-29	10	1	73.0241.0.300	3-35	8	1	73.0287.0.300	3-17	12	1
73.0187.0.300	3-31	17	1	73.0242.0.600	3-35	9	1	73.0288.0.600	3-81	9	1
73.0188.0.050	3-29	11	1	73.0243.0.300	3-35	10	1	73.0289.0.300	3-81	1	1
73.0189.0.800	3-31	18	2	73.0244.0.100	3-35	11	1	73.0291.0.000	3-81	10	1
73.0190.0.800	3-31	19	1	73.0245.0.800	3-59	21	1	73.0295.0.300	3-57	33	1
73.0191.0.300	3-15	11	1	73.0246.0.800	3-59	22	1	73.0296.0.300	3-25	56	1
73.0192.0.300	3-15	12	1	73.0247.0.800	3-59	23	1	73.0297.0.100	3-33	30	2
73.0193.0.600	3-15	13	1	73.0248.0.600	3-59	24	1	73.0298.0.800	3-65	3	1
73.0194.0.600	3-15	14	1	73.0249.0.200	3-39	25	3	73.0299.0.800	3-65	4	1
73.0195.0.300	3-15	15	1	73.0250.0.992	3-39	30	(2)	73.0300.0.800	3-65	5	2
73.0196.0.600	3-15	16	1	73.0251.0.600	3-59	25	1	73.0301.0.800	3-9	18	1
73.0197.0.400	3-15	17	1	73.0253.0.100	3-9	5	1	73.0302.0.600	3-63	19	1
73.0198.0.100	3-63	18	2	73.0254.0.300	3-31	20	1	73.0303.0.600	3-37	17	4
73.0199.0.100	3-19	33	(1)+(1)	73.0255.0.300	3-31	21	1	73.0304.0.000	3-25	57	1
73.0200.0.300	3-15	18	2	73.0256.0.600	3-31	22	1	73.0305.0.000	3-67	39	1
73.0203.0.300	3-15	37	2	73.0257.0.600	3-31	23	1	73.0306.0.600	3-67	40	1
73.0204.0.500	3-15	19	2	73.0258.0.600	3-31	24	1	73.0308.0.600	3-69	4	(1)
73.0205.0.400	3-15	34	2	73.0259.0.600	3-31	25	1	73.0309.0.600	3-71	4	(1)
73.0210.0.800	3-69	3	(4)	73.0260.0.800	3-33	15	1	73.0310.0.600	3-69	2	(1)
73.0210.0.800	3-71	3	(2)	73.0261.0.600	3-33	16	1	73.0310.0.600	3-71	2	(1)
73.0212.0.300	3-69	5	(1)	73.0262.0.600	3-33	17	1	73.0311.0.300	3-37	38	1
73.0212.0.300	3-71	5	(1)	73.0263.0.600	3-33	18	1	73.0312.0.600	3-25	59	1
73.0214.0.600	3-73	1	(1)	73.0264.0.800	3-33	19	1	73.0313.0.800	3-67	41	1
73.0215.0.800	3-73	2	(1)	73.0265.0.800	3-33	20	1	73.0314.0.000	3-25	60	2
73.0216.0.800	3-73	3	(1)	73.0266.0.100	3-33	21	2	73.0316.0.991	3-75	5	1
73.0217.0.800	3-73	4	(2)	73.0267.0.100	3-33	22	1	73.0321.0.800	3-57	26	1
73.0221.0.800	3-47	40	1	73.0268.0.600	3-33	23	1	73.0322.0.500	3-7	23	1
73.0222.0.100	3-57	32	1	73.0269.0.600	3-33	24	1	73.0323.0.600	3-7	24	1
73.0223.0.800	3-29	12	1	73.0270.0.600	3-33	25	1	73.0324.0.400	3-7	25	1
73.0224.0.200	3-33	14	1	73.0271.0.300	3-33	26	1	73.0325.0.800	3-43	16	1
73.0225.0.800	3-25	55	1	73.0272.0.800	3-33	27	1	73.0326.0.800	3-45	16	1
73.0226.0.800	3-47	41	1	73.0273.0.800	3-33	28	2	73.0327.0.800	3-43	17	1
73.0227.0.300	3-47	42	1	73.0274.0.100	3-9	6	2	73.0327.0.800	3-45	17	1
73.0228.0.400	3-47	43	1	73.0274.0.100	3-33	29	2	73.0330.0.800	3-83	22	1
73.0230.0.600	3-39	14	(1)	73.0274.0.100	3-65	2	2	73.0331.0.600	3-83	23	1
73.0231.1.800	3-39	15	(1)	73.0275.0.600	3-29	13	1	73.0336.0.600	3-37	32	1
73.0232.0.600	3-39	19	(3)+(3)	73.0276.0.600	3-29	14	1	73.0336.0.600	3-85	12	1
73.0233.0.200	3-39	18	(1)	73.0277.0.600	3-29	15	1	73.0337.0.600	3-37	20	1

INDEX

PART NUMBER	PAGE	DET	QTY	PART NUMBER	PAGE	DET	QTY	PART NUMBER	PAGE	DET	QTY
73.0337.0.600	3-85	14	1								
73.0338.0.600	3-37	21	1								
73.0338.0.600	3-85	13	1								
73.0342.0.800	3-51	42	1								
73.0343.0.100	3-51	43	4								
73.7002.1.050	3-51	40	1								
73.9005.0.050	3-41	43	1								
73.9006.0.050	3-41	44	1								
73.9008.0.050	3-51	41	1								
73.9022.0.050	3-63	20	1								
73.9028.0.050	3-81	8	1								
73.9901.0.601	3-43	18	1								
73.9901.0.601	3-45	18	1								
73.9901.0.602	3-81	4	2								
73.9902.0.801	3-37	34-1	1								
73.9902.0.802	3-37	34-2	0								
73.9902.0.802	3-81	5	1								
73.9903.0.054	3-73	7	1								
73.9903.0.054	3-81	3	1								
73.9903.0.055	3-69	6	1								
73.9903.0.056	3-71	6	1								
73.9903.0.056	3-81	2	1								
73.9904.1.055	3-39	24-2	0								
73.9904.1.055	3-81	6	1								
73.9904.1.056	3-39	24-1	1								
73.9905.0.601	3-29	18-1	1								
73.9905.0.602	3-29	18-2	0								
73.9905.0.602	3-81	7	1								
73.9906.0.601	3-81	12	1								
73.9906.0.602	3-81	13	1								
84.0003.0.390	3-79	11	1								
94.0093.9.010	3-75	6	1								
94.0093.9.077	3-83	24	2								
94.0093.9.079	3-83	25	3								