

## TABLE OF CONTENTS

---

CRANK MECHANISM .....	3-2
NEEDLE BAR FIXED .....	3-4
NEEDLE BAR SLIDING .....	3-6
NEEDLE BAR SLIDING .....	3-7
DRIVE EXPANSION OF NEEDLE BARS .....	3-8
THREAD TAKE-UP LEVER .....	3-10
TAKE-UP THREAD + TENSION .....	3-12
TENSION DISC AND THREAD GUIDE .....	3-14
THREAD PICK-UP .....	3-16
BASE .....	3-18
RACE - FIXED .....	3-22
RACE - SLIDING .....	3-24
THREAD TRIMMING .....	3-26
LUBRICATION .....	3-28
MAIN DRIVE .....	3-30
COVERS .....	3-32
CLAMPING + AXES X, Y .....	3-34
DRIVE AXES X-Y .....	3-36
CLAMPING LOOP .....	3-38
CUTTING .....	3-42
CUTTING LEVER .....	3-44
CUTTING STEEL .....	3-46
HOLER KNIFE .....	3-48
HOLER LOOP .....	3-50
LOADER MECHANISM AXIS X .....	3-52
FEED HEAD .....	3-56
CENTRAL ARM .....	3-58
FIXED ARM .....	3-60
FLEXIBLE ARM .....	3-62
RIDER .....	3-64
LOADER MECHANISM AXIS Y .....	3-66
FEED AXIS Y - ASSEMBLY .....	3-68
LENGTH SETTINGS EYELET .....	3-70
EQUIPMENT BASE PLATE .....	3-72
KIT ATLAS SINGLE - HANDED SWITCH .....	3-74
BELT-LOOP ALIGNMENT .....	3-76
TABLE ASSEMBLY .....	3-80
FILTER REGULATOR .....	3-82
VALVE BLOCK .....	3-84
ELECTROBOX .....	3-86
ACCESSORIES .....	3-90
ACCESSORIES .....	3-92
ACCESSORIES .....	3-94
ACCESSORIES .....	3-96
ACCESSORIES .....	3-98

# CRANK MECHANISM

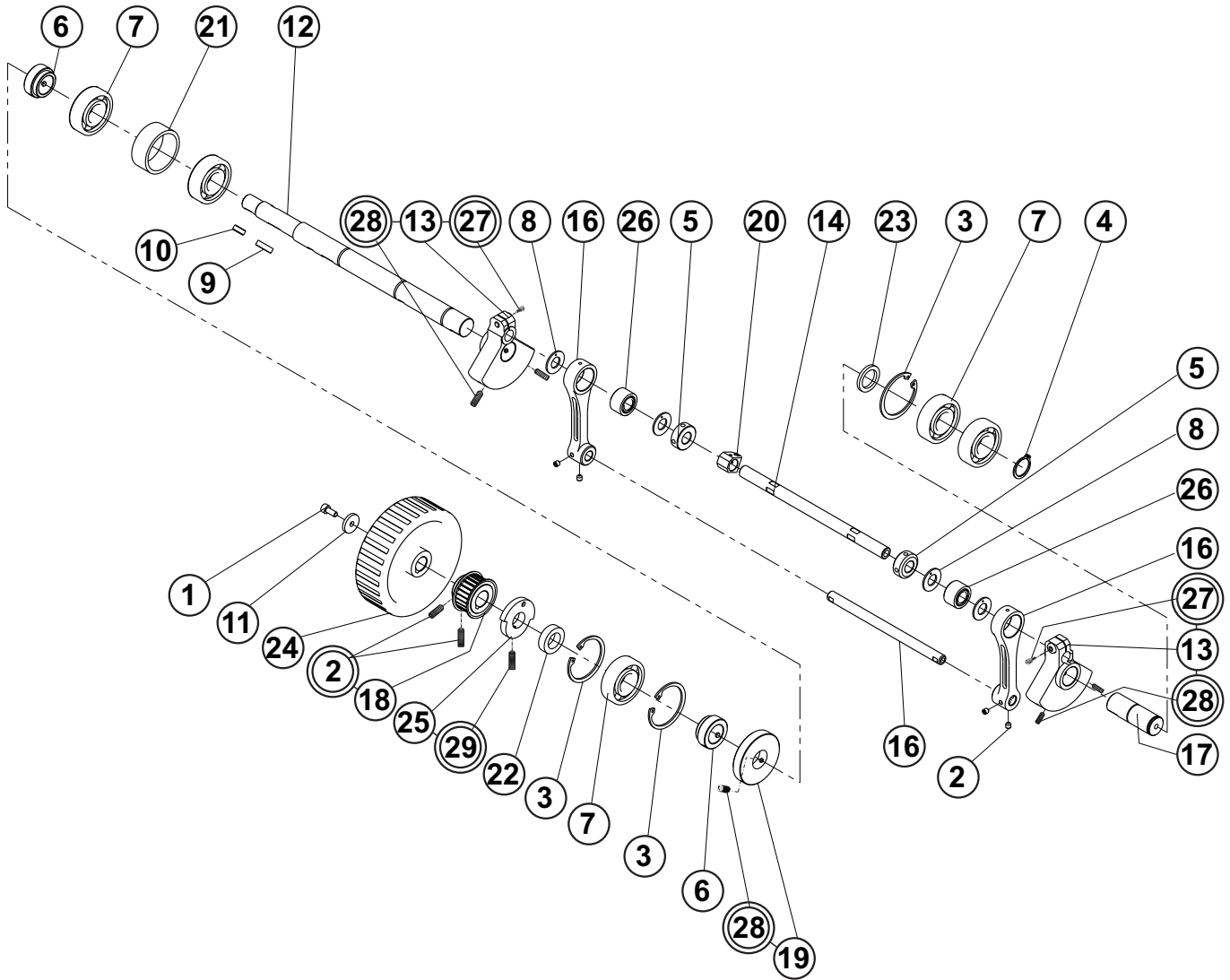

## CRANK MECHANISM

DET	PART NUMBER	DESCRIPTION	QTY.
01	08.6002.5.012	SCREW M5-12	1
02	08.6400.5.005	SCREW M5-5	4 + (2)
03	12.1040.1.016	RETAINING RING 47	4
04	12.1045.1.014	RETAINING RING 20	1
05	12.1050.0.006	RING 12	2
06	12.1050.0.009	RING 20	2
07	12.2010.0.042	BEARING	5
08	12.2086.0.001	BUSHING AXIS	4
09	12.4030.0.001	KEY 5h9x5h9x20	1
10	12.4030.0.514	KEY 5e9x5x14	1
11	15.1146.0.400	WASHER	1
12	50.0001.0.300	SHAFT	1
13	50.0002.0.600	UPPER SHAFT CRANK	2
14	50.0003.0.300	SHAFT	1
15	50.0004.0.300	SHAFT	1
16	50.0005.0.600	PISTON ROD	2
17	50.0006.0.300	SHAFT	1
18	50.0007.0.500	PULLEY 24z	1
19	50.0008.0.400	DISK	1
20	50.0009.0.600	RIDER	1
21	50.0099.0.400	DISTANCE RING	1
22	50.0011.0.400	DISTANCE RING	1
23	50.0012.0.400	DISTANCE RING	1
24	50.0013.0.400	HANDWHEEL	1
25	50.0014.0.600	SENSOR RING	1
26	50.0025.0.000	BEARING	2
27	50.0029.0.400	DISTANCE RING	1
28	08.6000.6.012	SCREW M6-12	(2)
29	08.6400.5.016	SCREW M5-16	(6)
30	08.6400.5.010	SCREW M5-10	(1)

# NEEDLE BAR FIXED

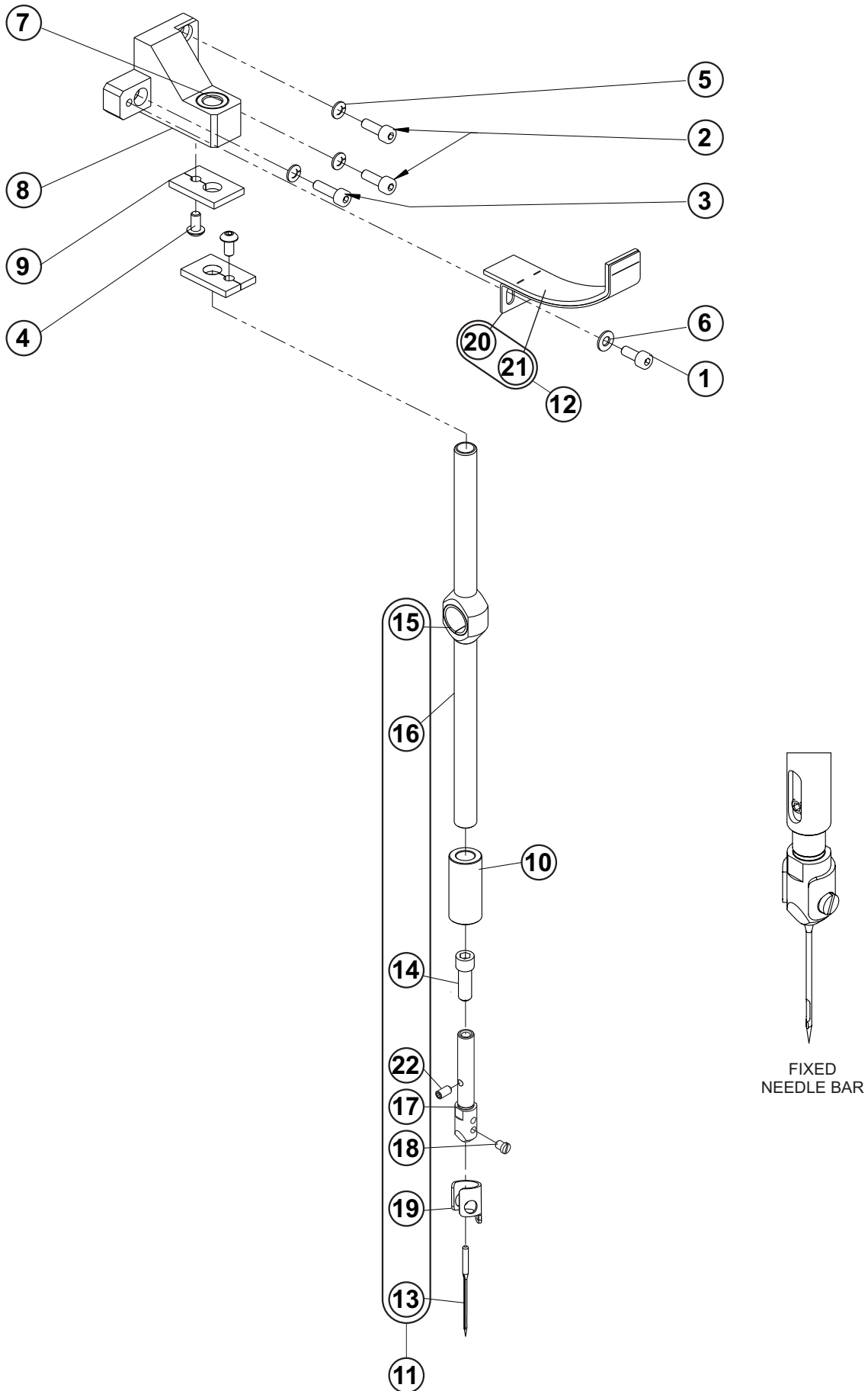

**NEEDLE BAR FIXED**

DET	PART NUMBER	DESCRIPTION	QTY.
01	08.6002.4.010	SCREW M4-10	1
02	08.6002.4.012	SCREW M4-12	2
03	08.6002.4.014	SCREW M4-14	1
04	08.6202.4.008	SCREW M4-8	2
05	08.6802.4.000	SPRING WASHER M4	3
06	08.6852.4.000	WASHER M4	1
07	12.2080.0.022	BUSHING	1
08	50.0019.0.600	CONSOLE	1
09	50.0020.0.991	FELT	2
10	50.0035.0.400	BUSHING	1
11	50.9002.0.050	NEEDLE BAR - ASSEMBLY	1
12	50.9022.0.050	FELT HOLDER - ASSEMBLY	1
13	02.0134.1.112	NEEDLE 134 - 110 Nm GEBEDUR	(1)
14	50.0438.0.100	SCREW M4-12	(1)
15	12.2080.0.028	BUSHING	(1)
16	50.0015.0.300	NEEDLE BAR	(1)
17	50.0016.1.300	NEEDLE HOLDER	(1)
18	50.0017.0.100	SCREW M3x0,35 - 3,5	(1)
19	50.0018.0.800	THREAD GUIDE	(1)
20	50.0021.0.800	FELT HOLDER	1
21	50.0022.0.991	FELT	1
22	08.6402.3.006	SCREW M3-6	(1)

# NEEDLE BAR SLIDING

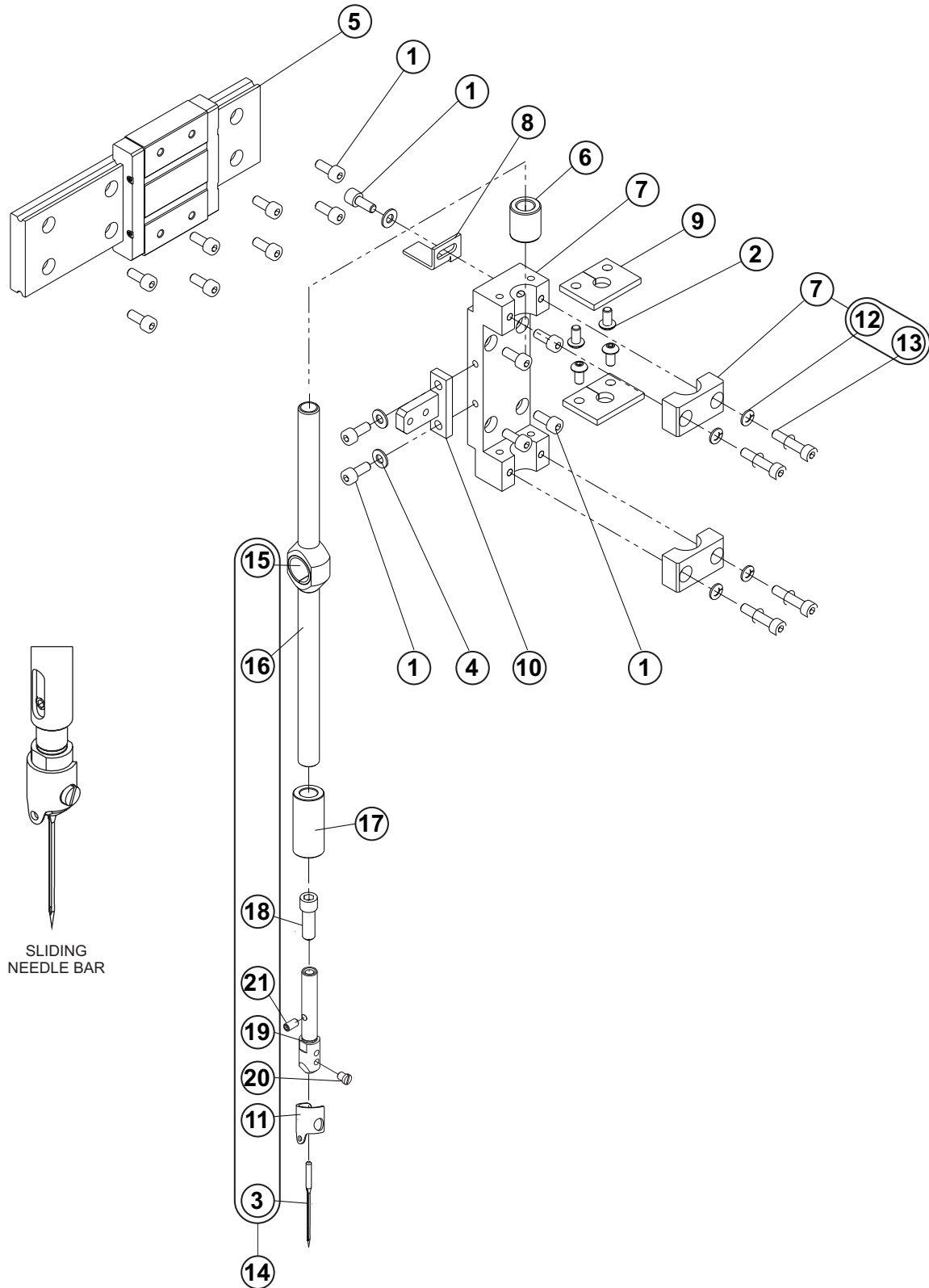

SLIDING  
NEEDLE BAR

**NEEDLE BAR SLIDING**

<b>DET</b>	<b>PART NUMBER</b>	<b>DESCRIPTION</b>	<b>QTY.</b>
01	08.6002.4.010	SCREW M4-10	15
02	08.6202.4.008	SCREW M4-8	4
03	02.0134.1.112	NEEDLE 134 - 110 Nm GEBEDUR	(1)
04	08.6852.4.000	WASHER M4	3
05	12.2070.1.052	GUIDE	1
06	12.2080.0.022	BUSHING	1
07	50.0023.0.600	BODY	1
08	50.0026.0.800	SENSOR PLATE	1
09	50.0027.0.991	FELT	2
10	50.0028.0.600	HOLDER	1
11	50.0018.0.800	THREAD GUIDE	(1)
12	08.6802.4.000	WASHER M4	(4)
13	08.6002.4.020	SCREW M4-20	(4)
14	50.9002.0.050	NEEDLE BAR - ASSEMBLY	1
15	12.2080.0.028	BUSHING	(1)
16	50.0015.0.300	NEEDLE BAR	(1)
17	50.0035.0.400	BUSHING	1
18	50.0438.0.100	SCREW M4-12	(1)
19	50.0016.1.300	NEEDLE HOLDER	(1)
20	50.0017.0.100	SCREW M3x0,35 - 3,5	(1)
21	08.6402.3.006	SCREW M3-6	(1)

# DRIVE EXPANSION OF NEEDLE BARS

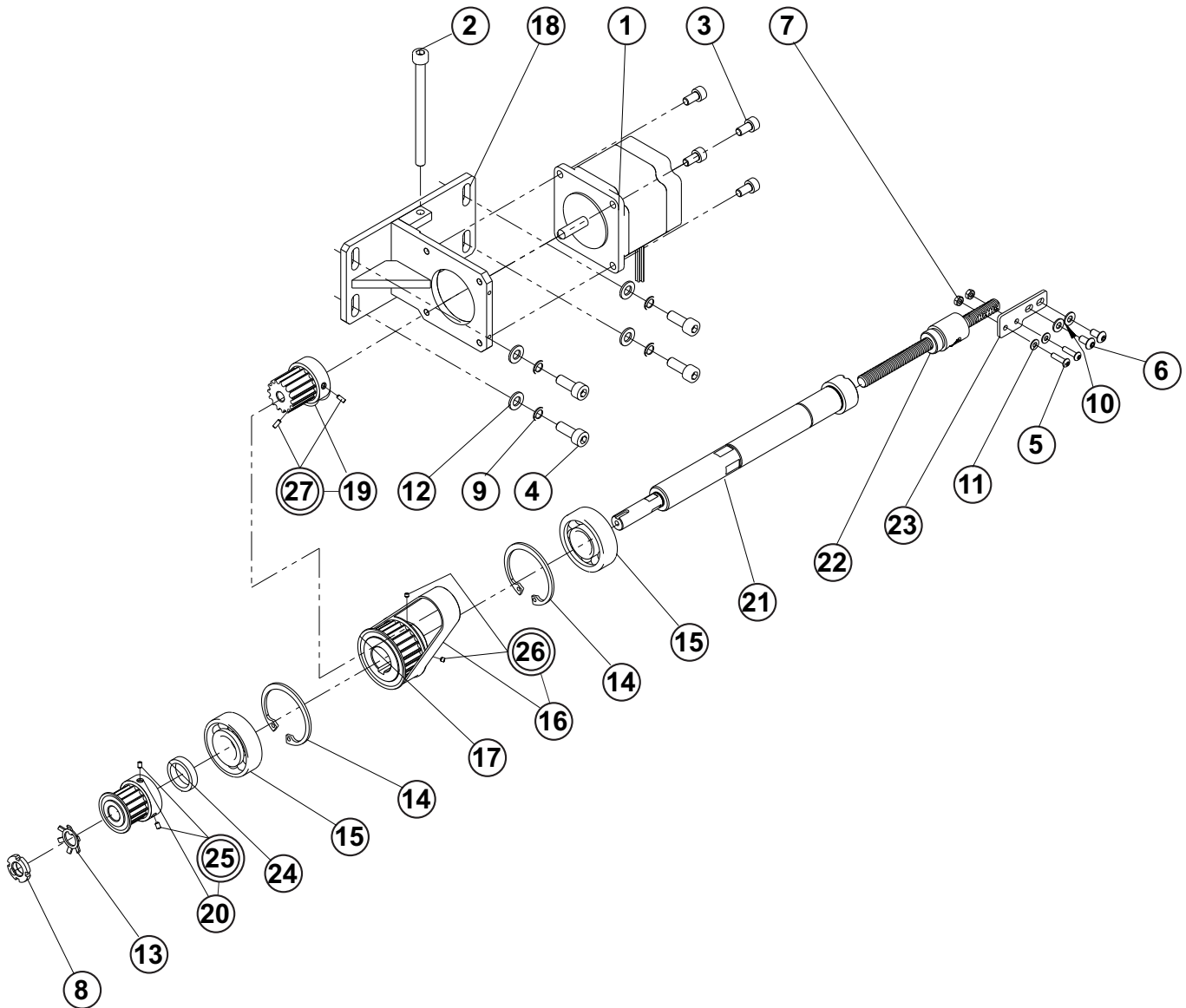



## DRIVE EXPANSION OF NEEDLE BARS

DET	PART NUMBER	DESCRIPTION	QTY.
01	06.5000.0.024	STEPPER MOTOR	1
02	08.6000.6.080	SCREW M6-80	1
03	08.6002.5.010	SCREW M5-10	4
04	08.6002.6.016	SCREW M6-16	4
05	08.6202.3.012	SCREW M3-12	2
06	08.6202.4.008	SCREW M4-8	2
07	08.6702.3.000	NUT M3	2
08	08.6792.0.300	NUT M10x0,75	1
09	08.6802.6.000	SPRING WASHER M6	4
10	08.6850.4.000	WASHER M4	2
11	08.6852.3.000	WASHER M3	2
12	08.6852.6.000	WASHER 6,4	4
13	08.6890.0.000	LOCK WASHER	1
14	12.1040.1.013	RETAINING RING 40	2
15	12.2010.0.046	BEARING	2
16	12.5050.2.042	BELT HTD 225-5M-15	1
17	50.0007.0.500	PULLEY	1
18	50.0030.0.000	HOLDER MOTOR	1
19	50.0031.0.500	PULLEY	1
20	50.0032.0.500	PULLEY	1
21	50.0034.0.300	SHAFT	1
22	50.0036.0.000	BALL SCREW - TOP	1
23	50.0037.0.800	TENON	1
24	50.0100.0.400	DISTANCE RING	1
25	08.6400.5.008	SCREW M5-8	(2)
26	08.6400.5.005	SCREW M5-5	(2)
27	08.6400.5.010	SCREW M5-10	(2)

# THREAD TAKE-UP LEVER

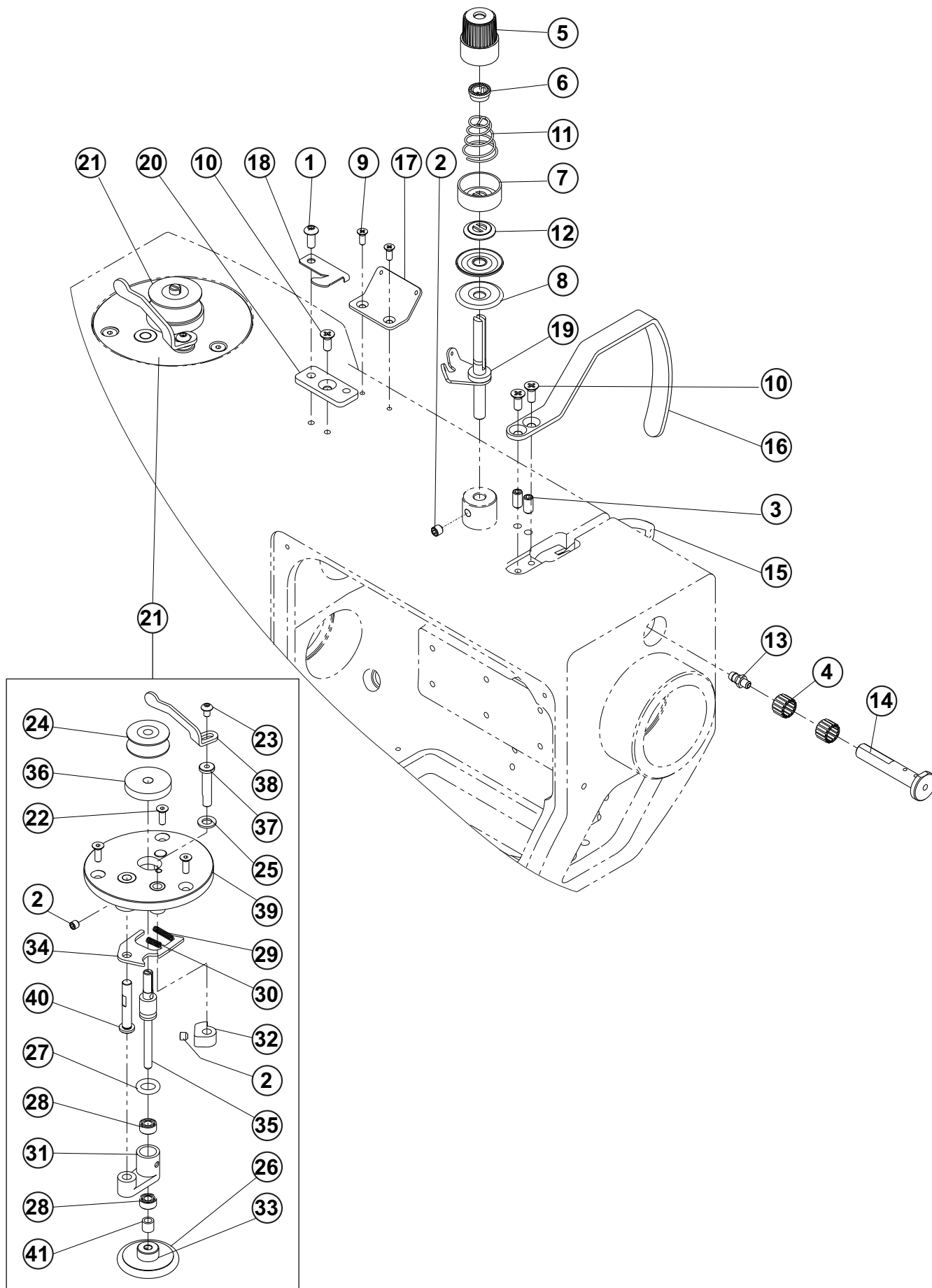

## THREAD TAKE-UP LEVER

DET	PART NUMBER	DESCRIPTION	QTY.
01	08.6202.4.010	SCREW M4-10	1
02	08.6400.5.005	SCREW M5-5	1+(2)
03	08.6400.5.010	SCREW M5-10	2
04	12.2050.0.014	BEARING	2
05	12.9900.9.001	NUT	1
06	12.9900.9.002	LOCK	1
07	12.9900.9.003	BOWL PLASTIC	1
08	15.1321.0.400	TENSION PLATE	2
09	15.1420.0.100	SCREW M3-8	2
10	15.1427.0.100	SCREW M4-10	3
11	24.0120.0.000	SPRING - CONCAL	1
12	17.0082.8.082	TENSION DISC	1
13	19.0044.1.623	NIPPLE, LUBRICATING M4	1
14	50.0042.0.300	STUD	1
15	50.0043.0.000	THREAD TAKE-UP LEVER	1
16	50.0044.0.800	COVER - THREAD TAKE-UP LEVER	1
17	50.0046.0.800	THREAD GUIDE	1
18	50.0047.0.800	HOLDER TREADS	1
19	50.0048.0.300	STUD	1
20	50.0056.0.800	PLATE	1
21	50.9012.0.050	WINDER RELL - ASSEMBLY	1
22	08.6102.4.012	SCREW M4-12	(3)
23	08.6202.4.006	SCREW M4-6	(1)
24	27378629	BOBBIN	(1)
25	08.6852.6.000	WASHER 6,4	(1)
26	12.0008.6.822	O-RING 5x30	(1)
27	12.0008.6.823	O-RING 3x9	(1)
28	12.2010.0.043	BEARING	(2)
29	12.3010.0.030	SPRING TL	(1)
30	12.3010.0.031	SPRING TL	(1)
31	50.0073.0.600	ARM	(1)
32	50.0074.0.600	RATCHET	(1)
33	50.0075.0.400	DISK	(1)
34	50.0076.0.800	PLATE	(1)
35	50.0077.0.300	SHAFT	(1)
36	50.0078.0.992	DISK	(1)
37	50.0079.0.300	STUD	(1)
38	50.0080.0.800	FINGER	(1)
39	50.0081.0.000	COVER	(1)
40	50.0082.0.300	STUD	(1)
41	50.0083.0.400	DISTANCE RING	(1)

# TAKE-UP THREAD + TENSION

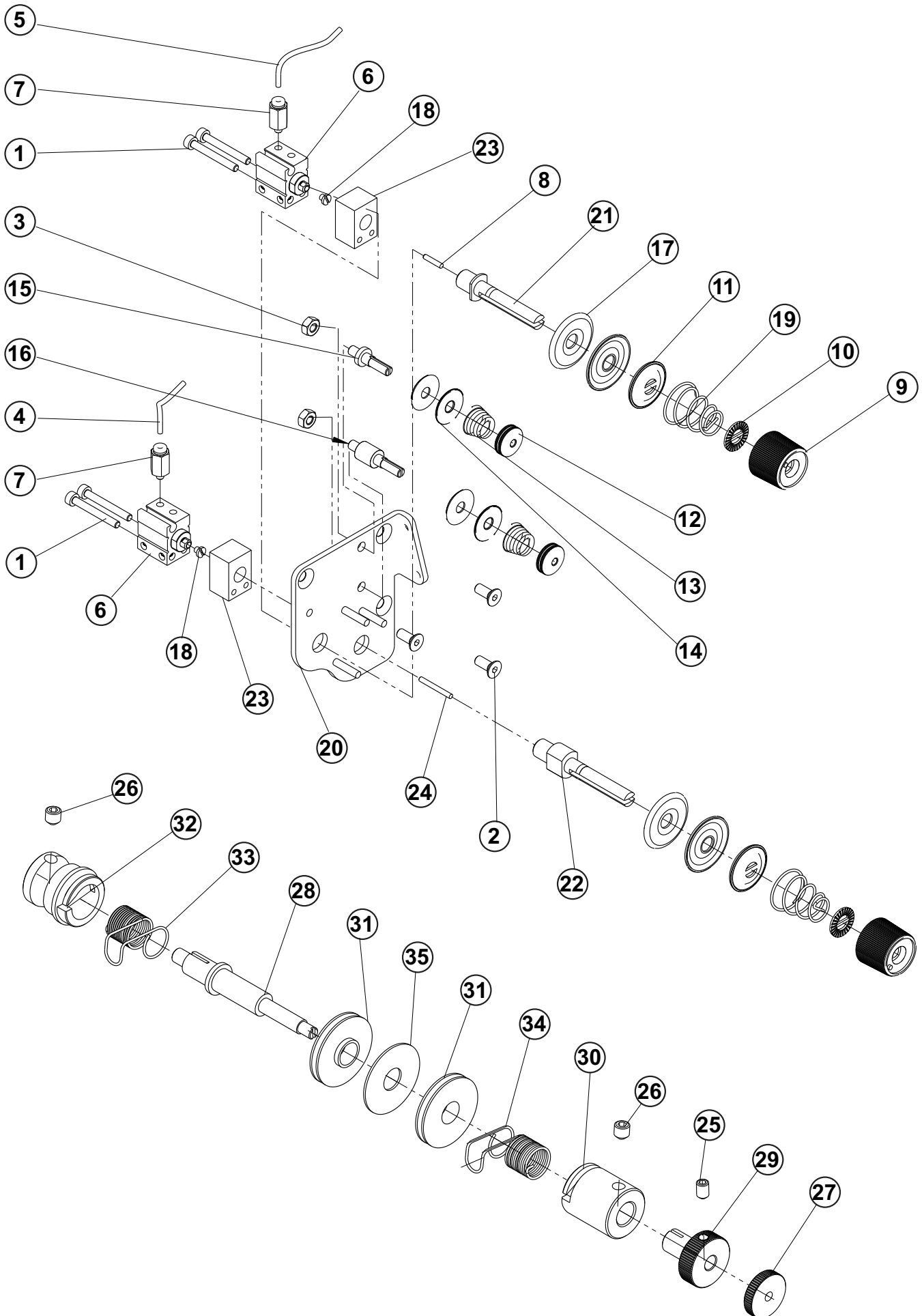

## TAKE-UP THREAD + TENSION

DET	PART NUMBER	DESCRIPTION	QTY.
01	08.6002.3.025	SCREW M3-25	4
02	08.6102.4.010	SCREW M4-10	3
03	12.9900.9.021	THREAD NUT	2
04	12.0008.3.749	AIR TUBING - 18A1	1
05	12.0008.3.749	AIR TUBING - 18A2	1
06	12.0010.3.013	CYLINDER	2
07	12.0010.3.071	CONNECTOR	2
08	12.1010.2.043	PIN 2h6-10	1
09	12.9900.9.011	THREAD NUT COMPLETE	2
10	12.9900.9.012	THREAD NUT REVOLUTION STOPPER	2
11	12.9900.9.013	THREAD TENSION RELEASING PLATE	2
12	12.9900.9.014	THREAD NUT	2
13	12.9900.9.015	THREAD TENSION SPRING	2
14	12.9900.9.016	THREAD TENSION DISK	4
15	12.9900.9.017	THREAD TENSION STUD	1
16	12.9900.9.018	THREAD TENSION STUD	1
17	15.1321.0.400	TENSION PLATE	4
18	17.0012.0.688	SCREW M2,5-2,5	2
19	17.0026.2.072	SPRING - CONCAL	2
20	50.0053.0.800	HOLDER	1
21	50.0054.0.300	STUD	1
22	50.0055.0.300	STUD	1
23	50.0057.0.600	BLOCK	2
24	50.0086.0.300	PIN	1
25	08.6400.4.006	SCREW M4-6	1
26	08.6400.5.005	SCREW M5-5	2
27	08.6772.4.000	NUT M4	1
28	50.0058.0.300	SHAFT	1
29	50.0059.0.400	HOLDER SPRING	1
30	50.0060.0.400	STOP SPRING	1
31	50.0061.0.400	DISK	2
32	50.0062.0.400	STOP SPRING	1
33	50.0063.0.200	SPRING - LEFT	1
34	50.0064.0.200	SPRING - RIGHT	1
35	50.0065.0.800	WASHER	1

# TENSION DISC AND THREAD GUIDE

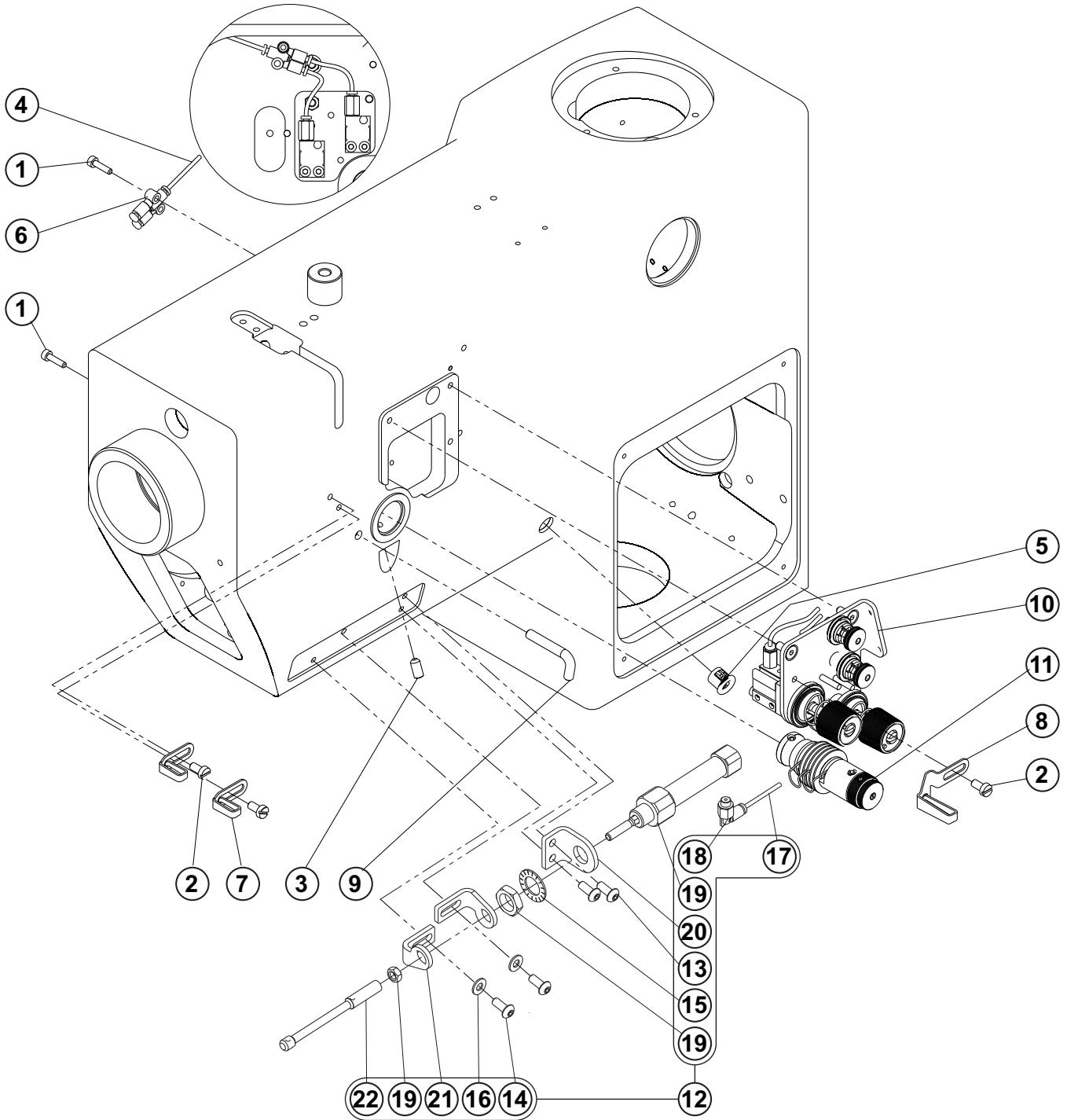

**TENSION DISC AND THREAD GUIDE**

<b>DET</b>	<b>PART NUMBER</b>	<b>DESCRIPTION</b>	<b>QTY.</b>
01	08.6002.3.012	SCREW M3-12	2
02	08.6012.4.008	SCREW M4-8	3
03	08.6400.5.010	SCREW M5-10	1
04	12.0008.3.749	AIR TUBING - 18A	1
05	12.0008.4.214	BUSHING HV6	1
06	12.0010.3.065	SMC CONNECTOR	1
07	50.0050.0.800	THREAD GUIDE	2
08	50.0051.0.800	THREAD GUIDE	1
09	50.0052.0.300	HOOK	1
10	50.9007.0.050	THREAD TENSION - ASSEMBLY	1
11	50.9008.0.050	TENSION - ASSEMBLY	1
12	50.9009.0.050	TAKE-UP THREAD - ASSEMBLY	1
13	08.6202.4.008	SCREW M4-8	(2)
14	08.6202.4.010	SCREW M4-10	(2)
15	08.6832.0.000	WASHER M10	(1)
16	08.6852.4.000	WASHER M4	(2)
17	12.0008.3.749	AIR TUBING	(1)
18	12.0010.3.064	CONNECTOR	(1)
19	12.0010.3.175	CYLINDER	(1)
20	50.0070.0.800	HOLDER	(1)
21	50.0071.0.800	THREAD GUIDE	(2)
22	50.0072.0.300	ROD	(1)

# THREAD PICK-UP

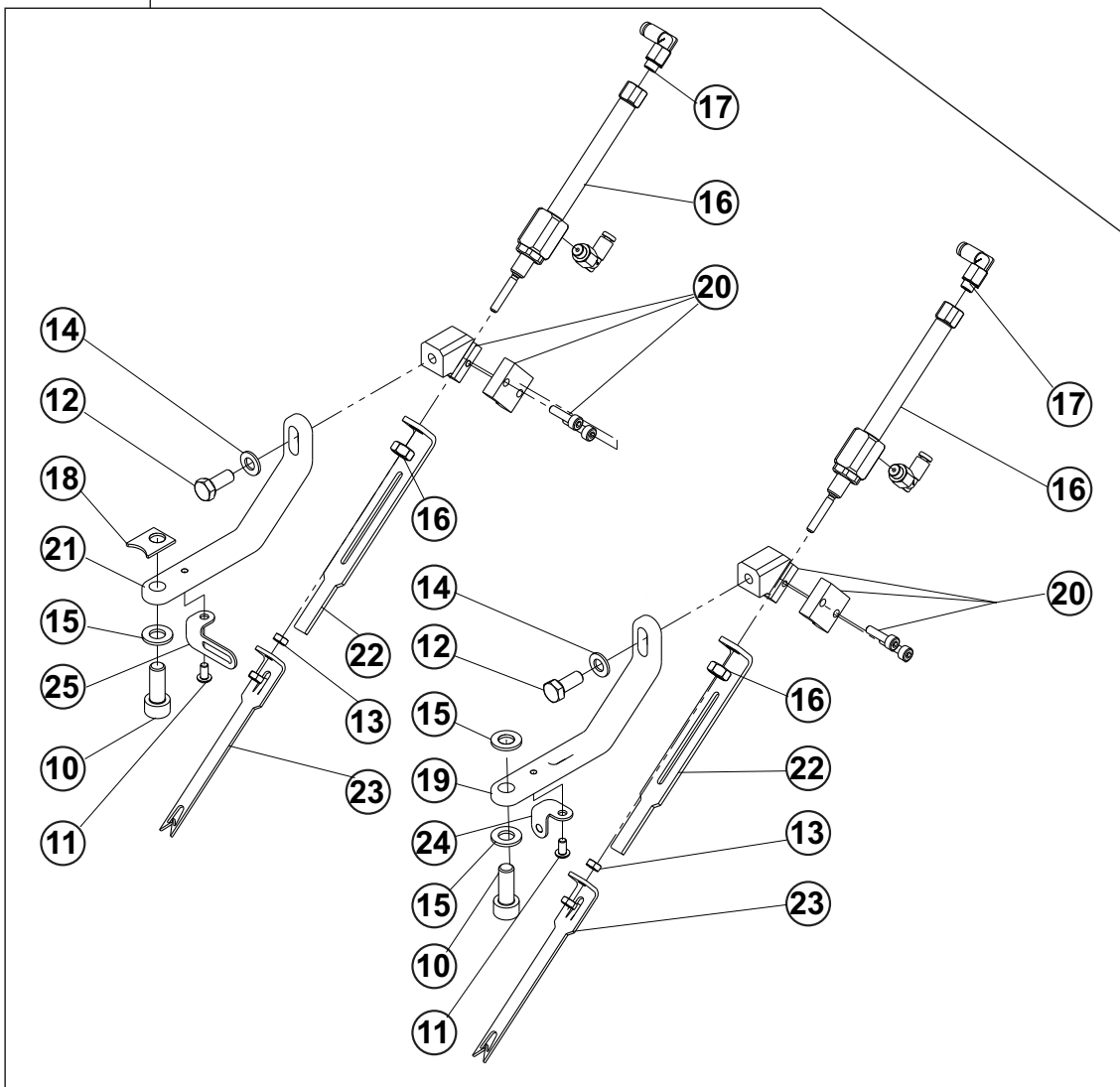
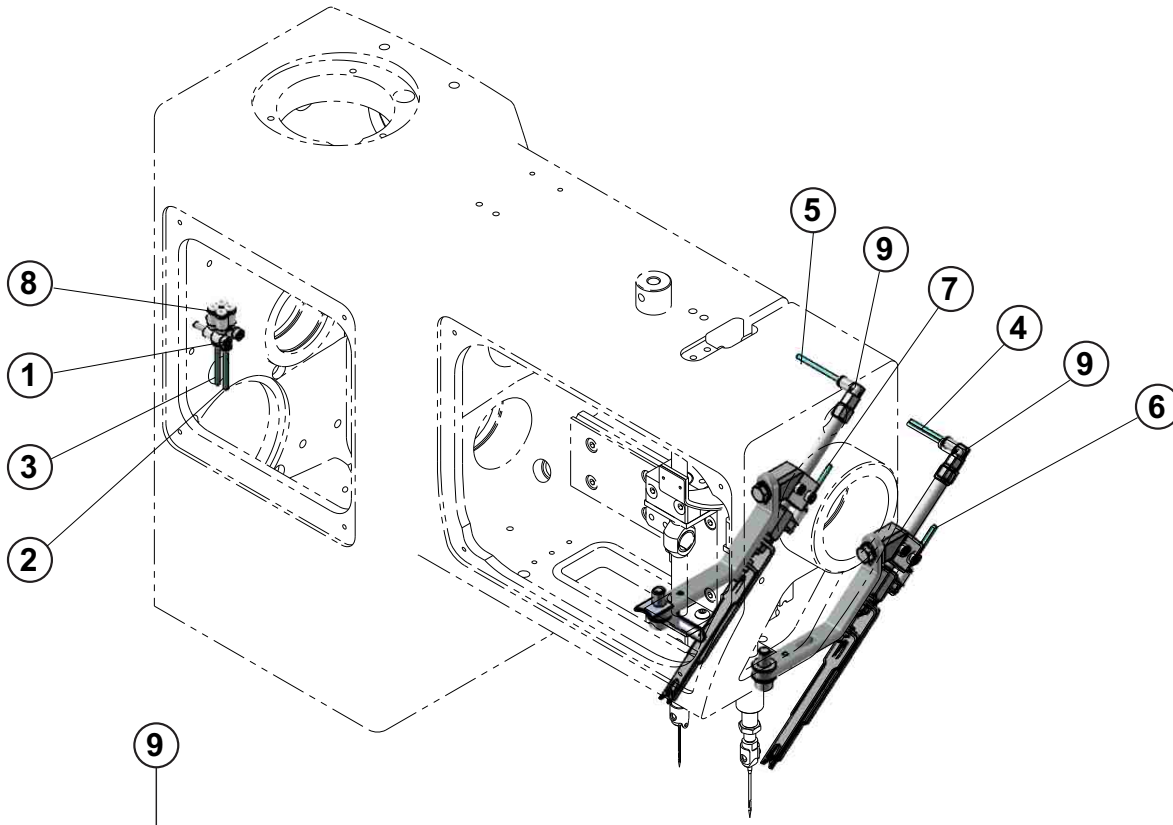



**THREAD PICK-UP**

DET	PART NUMBER	DESCRIPTION	QTY.
01	08.6002.3.020	SCREW M3-20	2
02	12.0008.3.749	AIR TUBING - 19A	1
03	12.0008.3.749	AIR TUBING - 19B	1
04	12.0008.3.749	AIR TUBING - 19A1	1
05	12.0008.3.749	AIR TUBING - 19A2	1
06	12.0008.3.749	AIR TUBING - 19B1	1
07	12.0008.3.749	AIR TUBING - 19B2	1
08	12.0010.3.065	SMC KQ2U02-00A CONNECTOR	2
09	50.9029.0.050	THREAD PICK-UP	1
10	08.6002.6.016	SCREW M6-16	(2)
11	08.6202.3.006	SCREW M3-6	(2)
12	08.6312.5.012	SCREW	(2)
13	08.6702.3.000	NUT M3	(2)
14	08.6852.5.000	WASHER 5,3	(2)
15	08.6852.6.000	WASHER 6,4	(3)
16	12.0008.3.499	CYLINDER	(2)
17	12.0010.3.064	CONNECTOR	(4)
18	50.0024.0.800	DISTANCE WASHER	(1)
19	50.0084.0.800	HOLDER	(1)
20	50.0085.0.600	CYLINDER BRACKET	(2)
21	50.0094.0.800	HOLDER	(1)
22	50.0137.0.800	THREAD CATCHER GUIDE	(2)
23	50.0138.0.800	THREAD CATCHER	(2)
24	50.0147.0.800	THREAD GUIDE	(1)
25	50.0148.0.800	THREAD GUIDE	(1)

# BASE

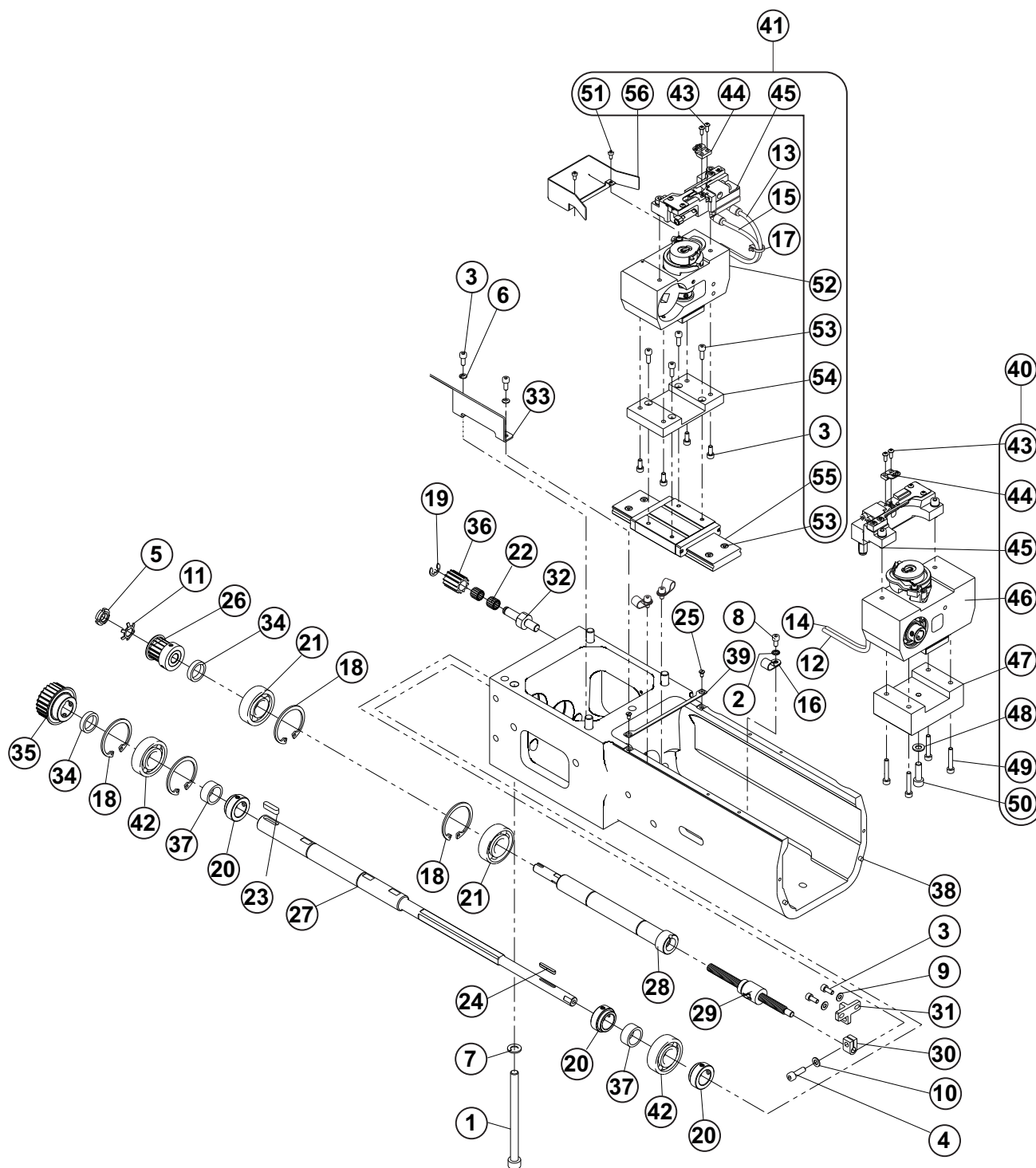

## BASE

DET	PART NUMBER	DESCRIPTION	QTY.
01	08.6000.8.110	SCREW M8-110	4
02	08.6002.4.008	SCREW M4-8	3
03	08.6002.4.010	SCREW M4-10	4 + (4)
04	08.6002.5.016	SCREW M5-16	1
05	08.6792.0.300	NUT M10x0,75	1
06	08.6802.4.000	SPRING WASHER M4	2
07	08.6802.8.000	SPRING WASHER M8	4
08	08.6832.4.000	WASHER M4	3
09	08.6852.4.000	WASHER M4	2
10	08.6852.5.000	WASHER 5,3	1
11	08.6890.0.000	LOCK WASHER MB0	1
12	12.0008.3.416	AIR TUBING - 20A1	1
13	12.0008.3.416	AIR TUBING - 20A2	1
14	12.0008.3.416	AIR TUBING - 20B1	1
15	12.0008.3.416	AIR TUBING - 20B2	1
16	12.0008.4.280	CLAMP CABLE	3
17	12.0008.4.290	CABLE TIE 2x100	1
18	12.1040.1.013	RETAINING RING 40	4
19	12.1045.0.007	RETAINER RING 7	1
20	12.1050.0.010	RING 17	3
21	12.2010.0.046	BEARING	2
22	12.2050.0.007	NEEDLE BEARING	2
23	12.4030.0.001	KEY	1
24	12.4030.0.322	KEY	1
25	15.1436.0.100	SCREW M3-6	2
26	50.0032.0.500	PULLEY 15z	1
27	50.0091.0.300	SHAFT	1
28	50.0092.0.300	SHAFT	1
29	50.0093.0.000	BALL SCREW - BOTTOM	1
30	50.0095.0.600	PROP	1
31	50.0096.0.600	HOLDER	1
32	50.0097.0.300	STUD	1
33	50.0098.0.800	COVER	1
34	50.0100.0.400	DISTANCE RING	2
35	50.0102.0.500	PULLEY 24z	1
36	50.0103.0.500	PULLEY 12z	1
37	50.0133.0.400	DISTANCE RING	2
38	50.0201.0.700	BASE - ATLAS	1
39	50.0387.0.800	BRACKET	1
40	50.9015.0.050	RACE-FIXED ASSEMBLY	1
41	50.9016.0.050	RACE - SLIDING ASSEMBLY	1
42	23231217	BEARING	2
43	08.6202.3.008	SCREW M3-8	(2) + (2)
44	50.9901.0.601	THROAT PLATE 2,6 - ATLAS	See page 3 - 96 (1) + (1)
45	50.9020.0.050	THREAD TRIMMING - ASSEMBLY	(1) + (1)
46	50.9017.0.050	RACE - FIXED	(1)

**BASE**

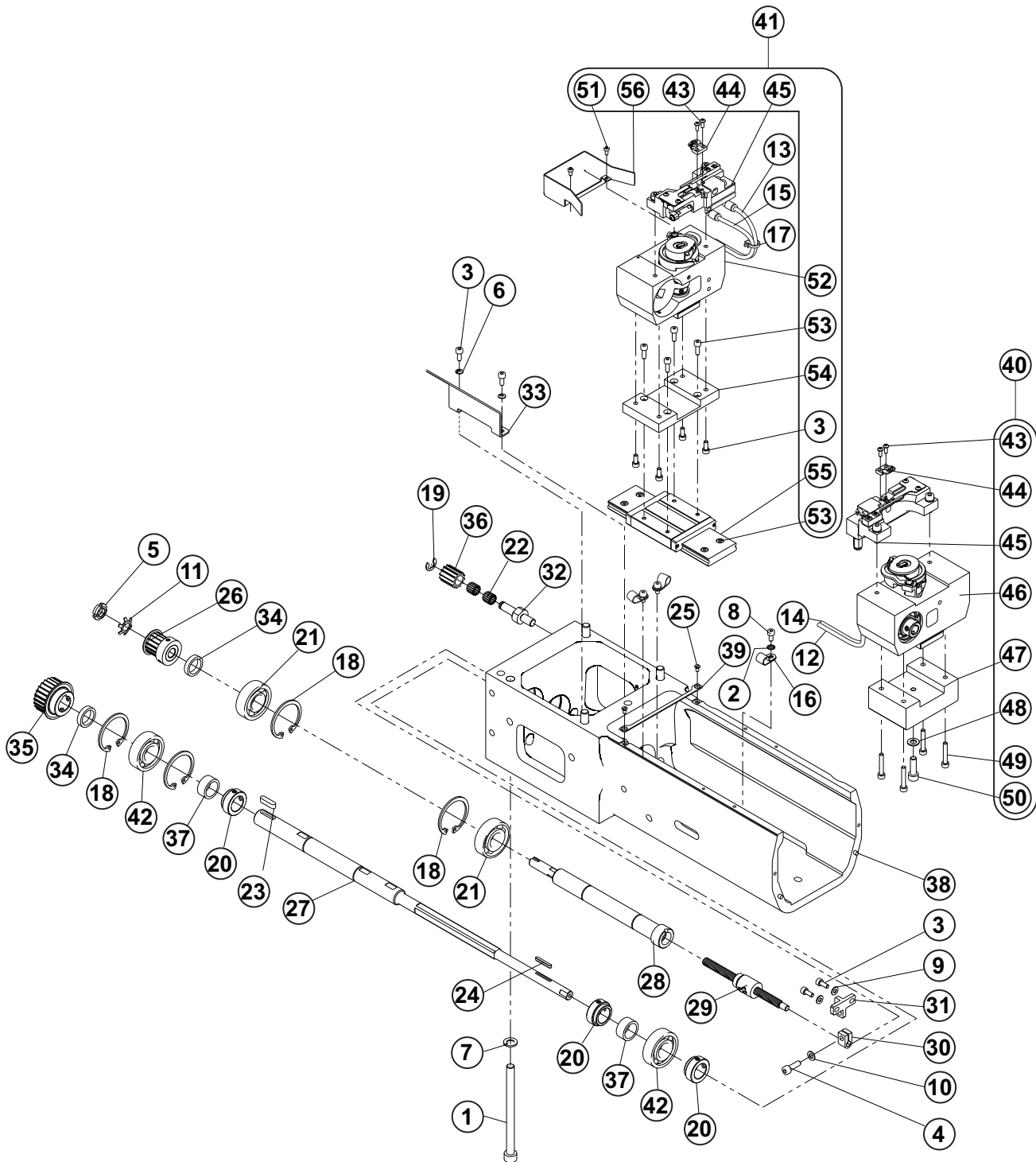



RACE - FIXED

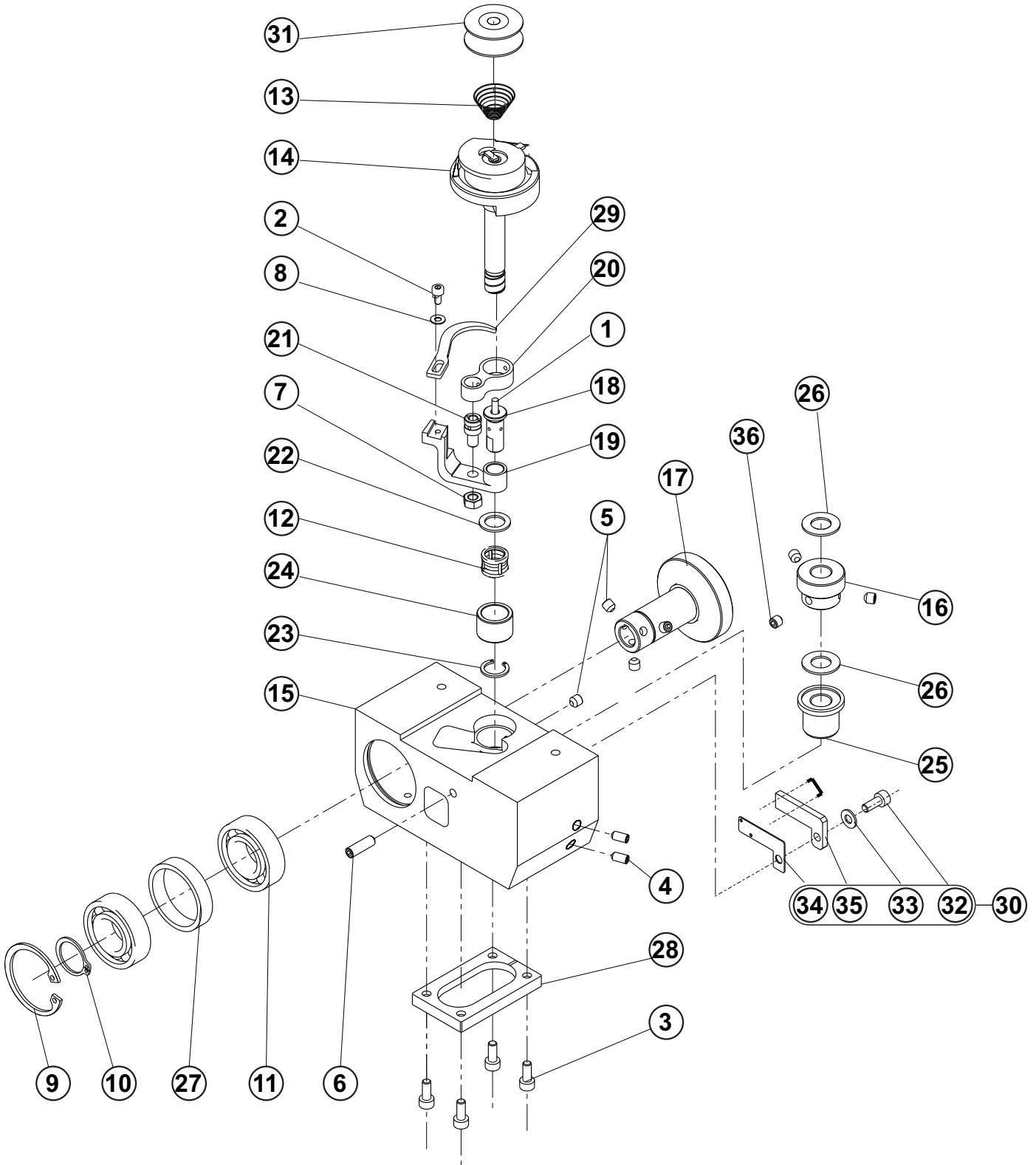

**RACE - FIXED**

DET	PART NUMBER	DESCRIPTION	QTY.
01	07.0400.0.000	WICK	
02	08.6002.3.006	SCREW M3-6	1
03	08.6002.4.008	SCREW M4-8	4
04	08.6400.4.008	SCREW M4-8	2
05	08.6400.5.005	SCREW M5-5	4
06	08.6400.5.016	SCREW M5-16	1
07	08.6700.5.000	NUT M5	1
08	08.6852.3.000	WASHER M3	1
09	12.1040.1.012	RETAINING RING 35	1
10	12.1045.1.017	CIRCLIP 17x1	1
11	12.2010.0.007	BEARING	2
12	12.2050.0.015	BEARING	1
13	12.3010.0.032	SPRING	1
14	50.0128.0.000	HOOK WITH CAP	1
15	50.0107.0.600	RACE BLOCK - FIXED	1
16	50.0109.0.500	GEAR z15	1
17	50.0110.0.500	GEAR z30	1
18	50.0112.0.300	STUD	1
19	50.0114.0.600	HOLDER	1
20	50.0115.0.600	LINK	1
21	50.0116.0.300	STUD	1
22	50.0117.0.400	WASHER	1
23	50.0118.0.800	RING RETAINING 12,7	1
24	50.0119.0.400	BUSHING - UPPER	1
25	50.0120.0.400	BUSHING - LOWER	1
26	50.0121.0.400	WASHER	2
27	50.0123.0.400	DISTANCE RING	1
28	50.0132.0.600	OIL SUMP	1
29	50.0136.0.800	OPENER	1
30	50.9019.0.050	FELT HOLDER-ASSEMBLY	1
31	27378629	BOBBIN	1
32	08.6012.4.010	SCREW M4-10	(1)
33	08.6852.4.000	WASHER M4	(1)
34	50.0134.0.800	FELT HOLDER	(1)
35	50.0135.0.991	FELT	(1)
36	08.6410.5.005	SCREW M5-5	3

# RACE - SLIDING

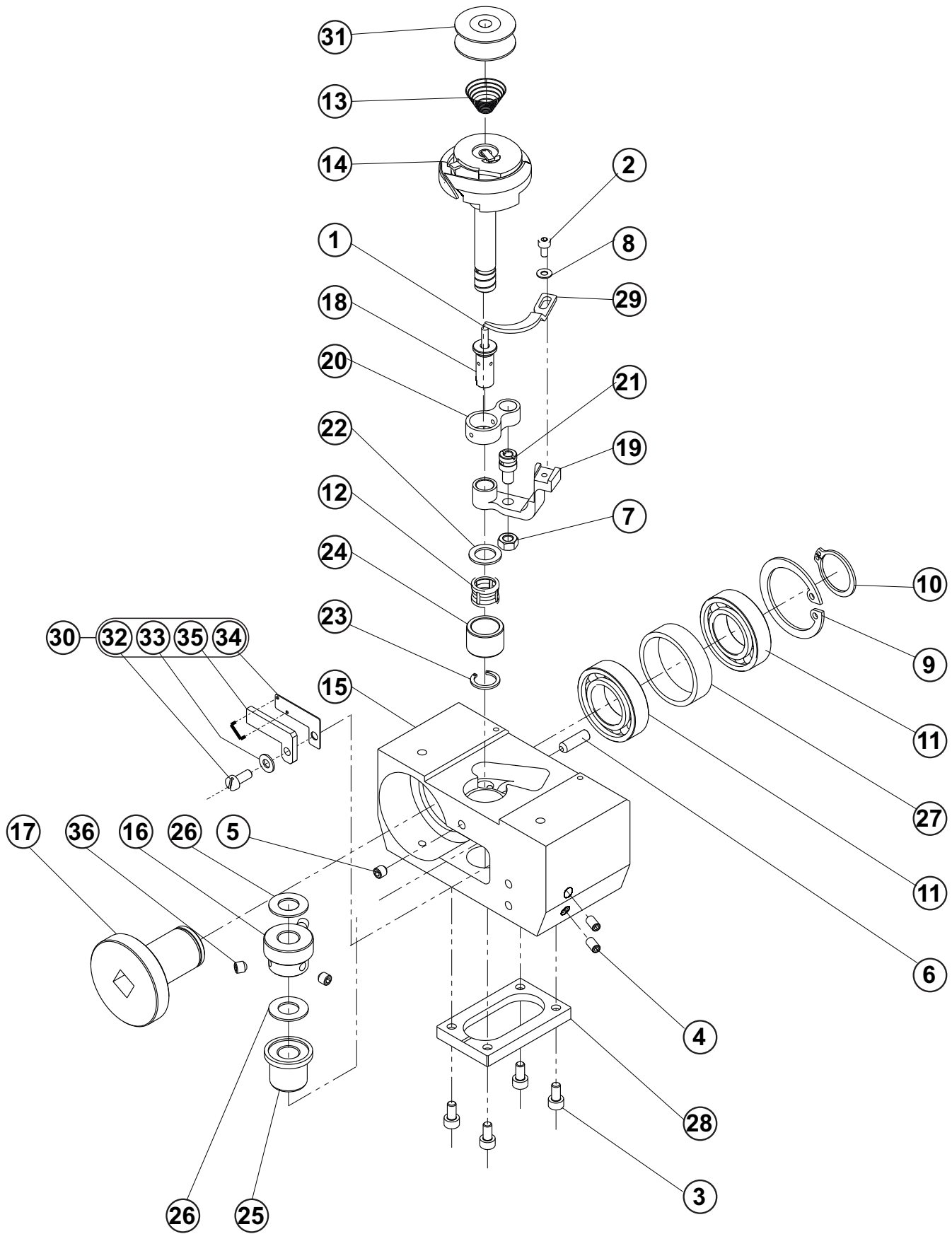



**RACE - SLIDING**

DET	PART NUMBER	DESCRIPTION	QTY.
01	07.0400.0.000	WICK	
02	08.6002.3.006	SCREW M3-6	1
03	08.6002.4.008	SCREW M4-8	4
04	08.6400.4.008	SCREW M4-8	2
05	08.6400.5.005	SCREW M5-5	1
06	08.6400.5.016	SCREW M5-16	1
07	08.6700.5.000	NUT M5	1
08	08.6852.3.000	WASHER M3	1
09	12.1040.1.010	RETAINING RING 37	1
10	12.1045.1.014	RETAINING RING 20	1
11	12.2010.0.045	BEARING	2
12	12.2050.0.015	BEARING	1
13	12.3010.0.032	SPRING	1
14	50.0128.0.000	HOOK WITH CAP	1
15	50.0108.0.600	RACE BLOCK - SLIDING	1
16	50.0109.0.500	GEAR z15	1
17	50.0111.0.500	GEAR z30	1
18	50.0113.0.300	STUD	1
19	50.0114.0.600	HOLDER	1
20	50.0115.0.600	LINK	1
21	50.0116.0.300	STUD	1
22	50.0117.0.400	WASHER	1
23	50.0118.0.800	RING RETAINING 12,7	1
24	50.0119.0.400	BUSHING - UPPER	1
25	50.0120.0.400	BUSHING - LOWER	1
26	50.0121.0.400	WASHER	2
27	50.0122.0.400	DISTANCE RING	1
28	50.0132.0.600	OIL SUMP	1
29	50.0136.0.800	OPENER	1
30	50.9019.0.050	FELT HOLDER-ASSEMBLY	1
31	27378629	BOBBIN	1
32	08.6012.4.010	SCREW M4-10	(1)
33	08.6852.4.000	WASHER M4	(1)
34	50.0134.0.800	FELT HOLDER	(1)
35	50.0135.0.991	FELT	(1)
36	08.6410.5.005	SCREW M5-5	3

# THREAD TRIMMING

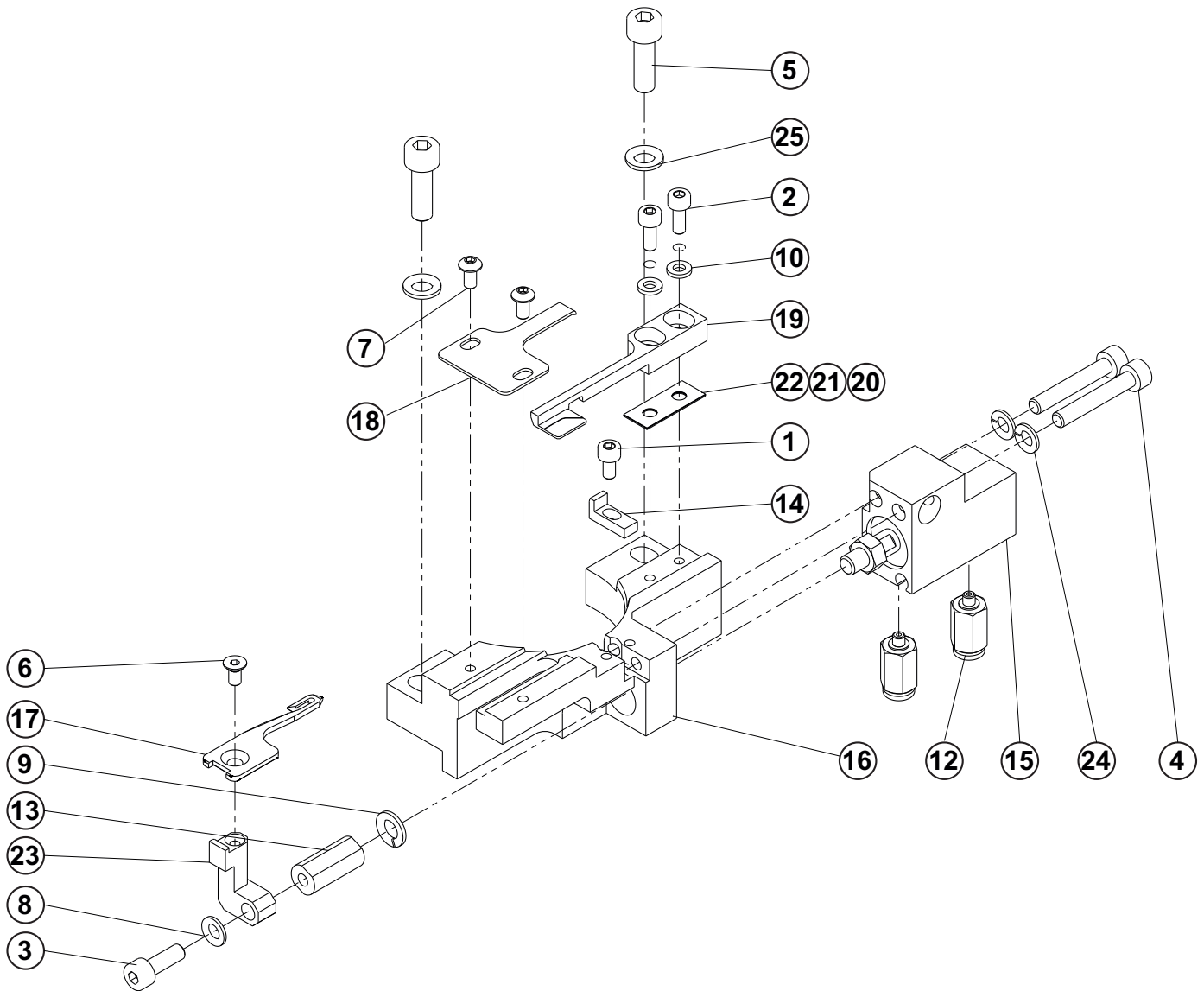

FIXED BLOCK

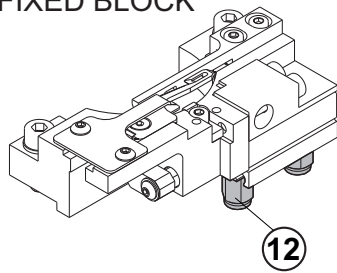

SLIDING BLOCK

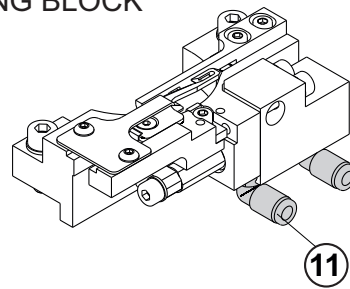

## THREAD TRIMMING

DET	PART NUMBER	DESCRIPTION	QTY.
01	08.6002.3.006	SCREW M3-6	1
02	08.6002.3.008	SCREW M3-8	2
03	08.6002.4.012	SCREW M4-12	1
04	08.6002.4.025	SCREW M4-25	2
05	08.6002.5.016	SCREW M5-16	2
06	08.6102.3.006	SCREW M3-6	1
07	08.6202.3.006	SCREW M3-6	2
08	08.6852.4.000	WASHER M4	1
09	08.6800.5.000	SPRING WASHER M5	1
10	08.6887.3.000	WASHER 1x3x6	2
11	12.0010.3.036	CONNECTOR	1
12	12.0010.3.119	CONNECTOR	1
13	50.0139.0.300	ROD	1
14	50.0152.0.600	NEEDLE GUARD	1
15	50.0156.0.000	CYLINDER	1
16	50.0160.0.600	BLOCK	1
17	50.0161.0.800	KNIFE - MOVING	1
18	50.0162.0.800	KNIFE	1
19	50.0163.0.600	BASKET RETAINER	1
20	50.0164.0.800	SPREAD PLATE t=0,1	1
21	50.0165.0.800	SPREAD PLATE t=0,2	1
22	50.0166.0.800	SPREAD PLATE t=0,3	1
23	50.0168.0.600	TENON	1
24	08.6800.4.000	SPRING WASHER M4	2
25	08.6852.5.000	WASHER M5	2

# LUBRICATION

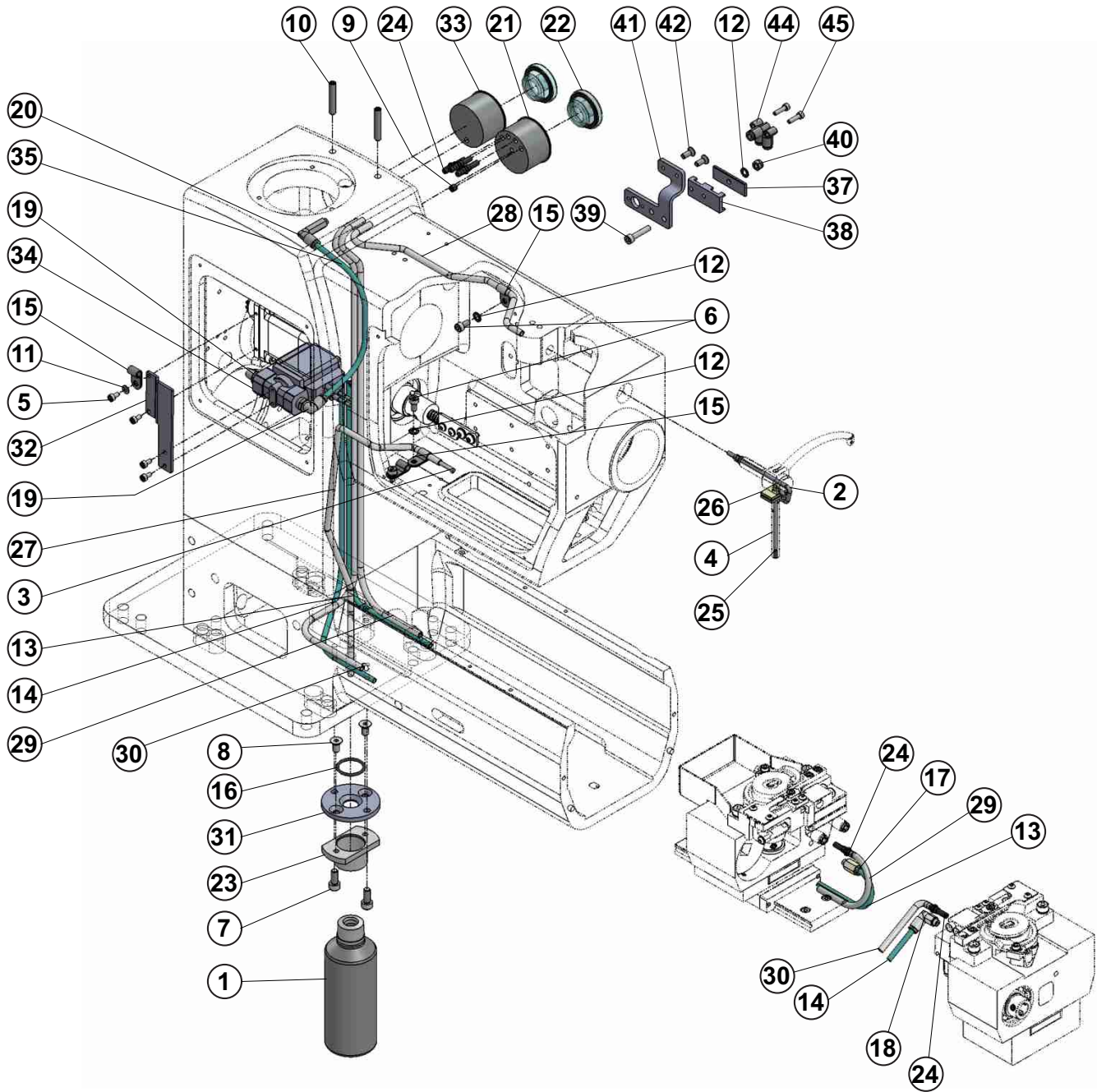

## LUBRICATION

DET	PART NUMBER	DESCRIPTION	QTY.
01	05.1322.0.000	OIL RESERVOIR	1
02	07.0400.0.000	WICKING	
03	07.0400.0.000	WICKING	
04	07.0400.0.000	WICKING	
05	08.6002.3.006	SCREW M3-6	4
06	08.6002.4.008	SCREW M4-8	3
07	08.6002.5.012	SCREW M5-12	2
08	08.6102.5.010	SCREW M5-10	2
09	08.6400.5.005	SCREW M5-5	1
10	08.6400.5.030	SCREW M5-30	2
11	08.6852.3.000	WASHER M3	1
12	08.6832.4.000	WASHER M4	4
13	12.0008.3.416	AIR TUBE- 22A1	1
14	12.0008.3.416	AIR TUBE- 22A2	1
15	12.0008.4.913	CLAMP CABLE	4
16	12.0008.6.812	O-RING 19x2	1
17	12.0010.3.027	CONNECTOR	1
18	12.0010.3.028	CONNECTOR	1
19	12.0010.3.090	CONNECTOR	2
20	12.0010.3.230	CONNECTOR	1
21	15.1130.0.400	OIL GAUGE RESERVOIR	1
22	17.0095.1.329	OIL INDICATOR	2
23	19.0044.5.404	HOLDER	1
24	22.0229.0.000	STRAIGHT FITTING	5
25	50.0033.0.990	PLUG	1
26	50.0045.0.991	FELT	1
27	50.0145.0.990	OIL TUBE - L1	
28	50.0145.0.990	OIL TUBE - L2	
29	50.0145.0.990	OIL TUBE - L3	
30	50.0145.0.990	OIL TUBE - L4	
31	50.0149.0.800	HOLDER	1
32	50.0153.0.800	HOLDER	1
33	50.0154.0.400	OIL GAUGE RESERVOIR	1
34	50.0155.0.000	VALVE	1
35	12.0008.3.416	AIR TUBE- 23A	1
36	12.0008.3.416	AIR TUBE- 23A	1
37	50.0425.0.800	WASHER	1
38	50.0424.0.600	SPLICE PLATE	1
39	08.6002.4.020	SCREW M4-20	1
40	08.6732.4.000	NUT M4	1
41	50.0426.0.800	HOLDER	1
42	08.6102.4.010	SCREW M4-10	2
43	08.6002.4.005	SCREW M4-5	1
44		KQ2LU04-00A	1
45	08.6002.3.012	SCREW M3-12	2

**MAIN DRIVE**

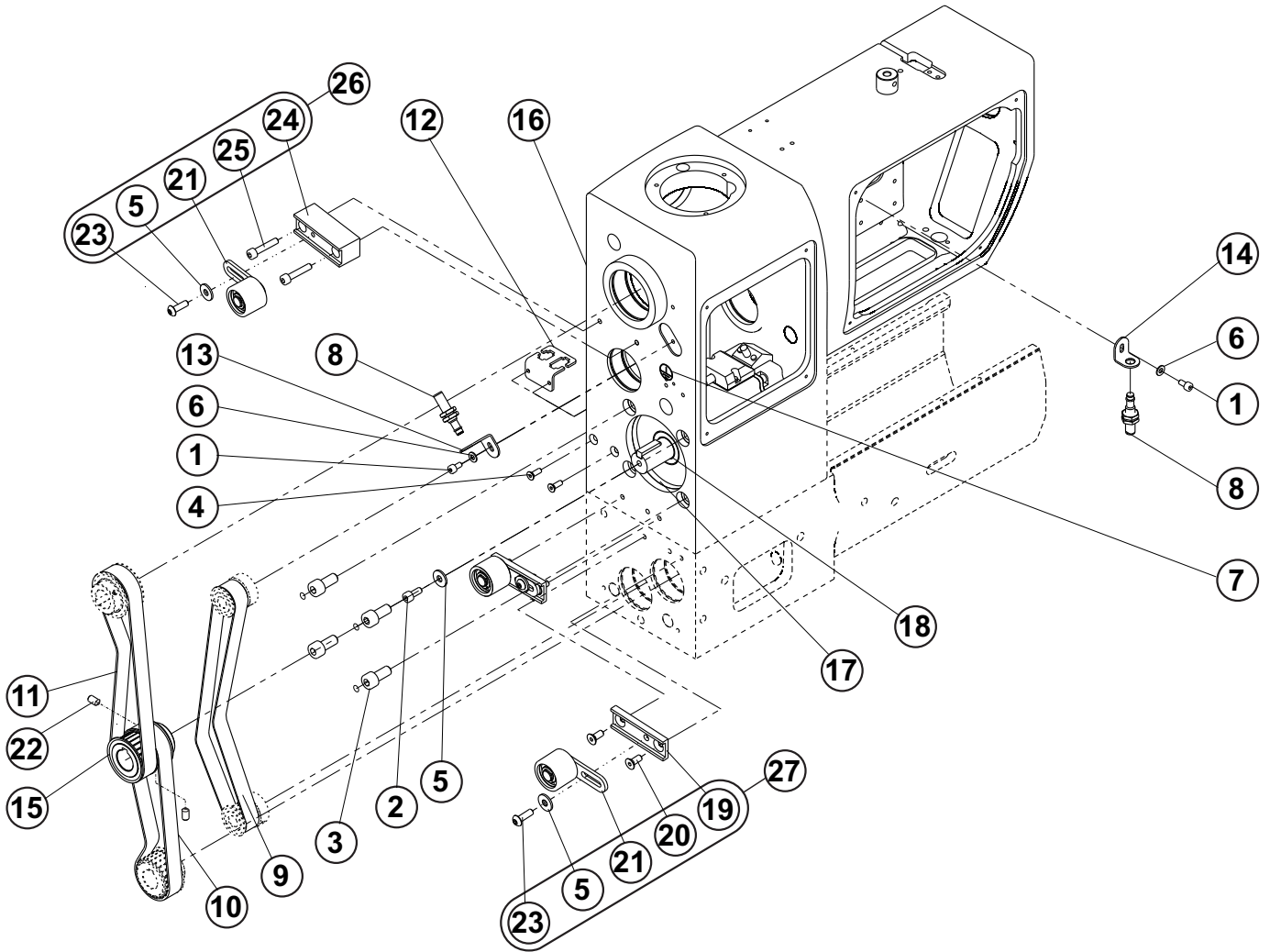

**MAIN DRIVE**

DET	PART NUMBER	DESCRIPTION	QTY.
01	08.6002.4.008	SCREW M4-8	2
02	08.6002.5.012	SCREW M5-12	1
03	08.6002.8.018	SCREW M8-18	4
04	08.6102.4.012	SCREW M4-12	2
05	08.6842.5.000	WASHER 5	1+(2)
06	08.6852.4.000	WASHER M4	2
07	12.0008.4.052	LABEL GROUND	1
08	12.0010.4.093	SENSOR BQ	2
09	12.5050.2.039	BELT HTD	1
10	12.5050.2.040	BELT HTD	1
11	12.5050.2.041	BELT HTD	1
12	15.1145.0.800	SERVO CABLE HOLDER	1
13	50.0066.0.800	SENSOR BRACKET	1
14	50.0067.0.800	SENSOR BRACKET	1
15	50.0068.0.500	PULLEY	1
16	50.0200.0.700	HEAD - ATLAS	1
17	50.0205.0.400	RING	1
18	50.0206.0.000	SERVOMOTOR	1
19	50.0038.0.600	HOLDER TENSION PULLEY	(1)
20	08.6102.5.012	SCREW M5-12	(2)
21	50.9023.0.050	TENSION PULLEY	(1)+(1)
22	08.6400.5.005	SCREW M5-5	2
23	08.6202.5.016	SCREW M5-16	(1)+(1)
24	50.0039.0.600	HOLDER TENSION PULLEY	(1)
25	08.6002.5.025	SCREW M5-25	(2)
26	50.9025.0.050	TENSION PULLEY-ASSEMBLY	1
27	50.9024.0.050	TENSION PULLEY-ASSEMBLY	1

# COVERS

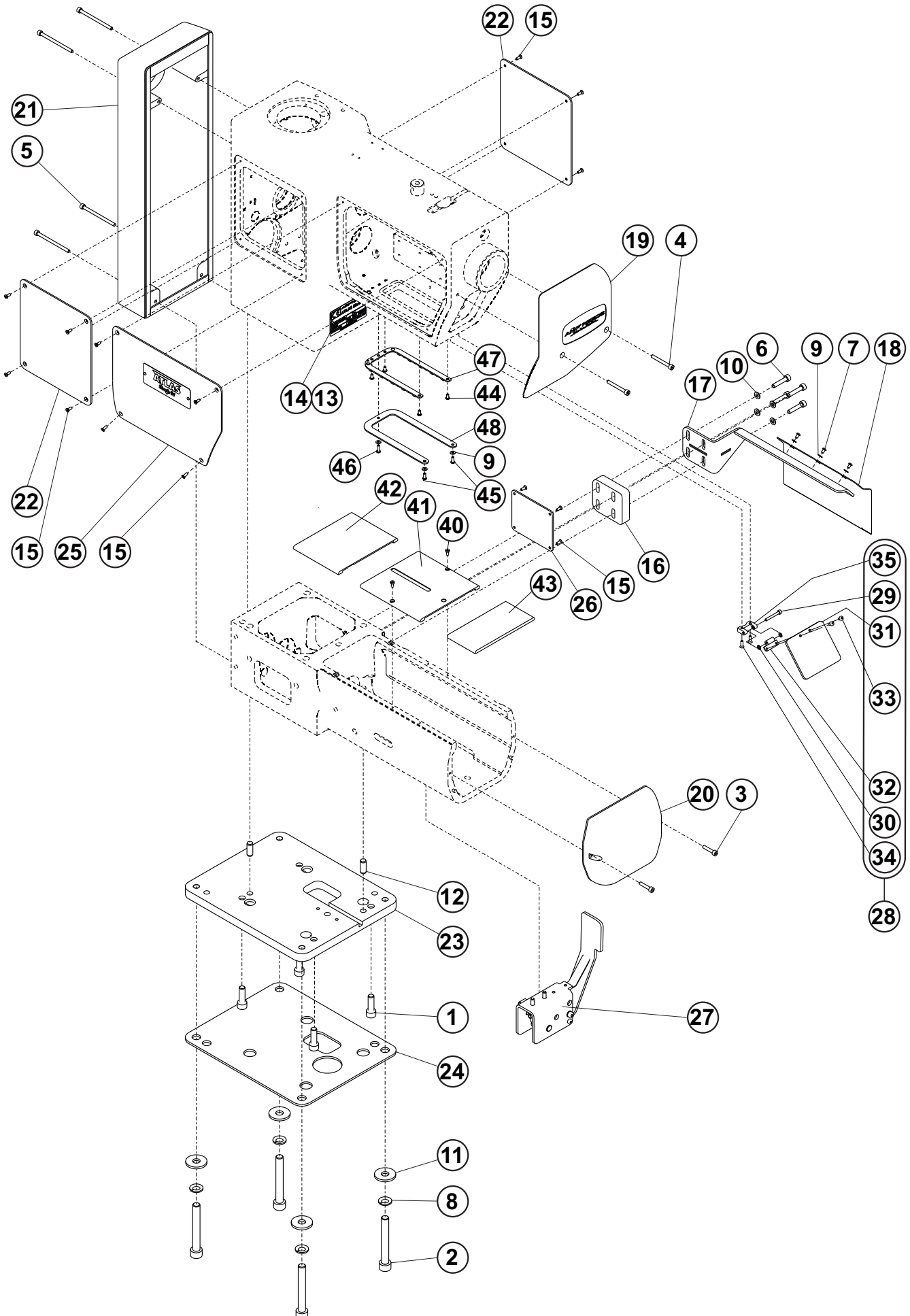



## COVERS

DET	PART NUMBER	DESCRIPTION	QTY.
01	08.6000.8.018	SCREW M8-18	4
02	08.6002.0.075	SCREW M10-75	4
03	08.6002.4.020	SCREW M4-20	2
04	08.6002.4.035	SCREW M4-35	2
05	08.6002.4.060	SCREW M4-60	4
06	08.6002.5.025	SCREW M5-25	4
07	08.6202.3.005	SCREW M3-5	3
08	08.6802.0.000	SPRING WASHER M10	4
09	08.6852.3.000	WASHER M3	3+3
10	08.6852.5.000	WASHER M5	4
11	08.6882.0.000	WASHER M10	4
12	12.1010.0.820	PIN 8-20	2
13	12.1016.0.000	RIVET	2
14	12.8000.1.049	LABEL CE ATLAS Mark IV	1
15	15.1420.0.100	SCREW M3-8	16
16	50.0150.0.600	SPACER PLATE	1
17	50.0173.0.000	COVER	1
18	50.0174.0.800	COVER	1
19	50.0175.0.000	FRONT COVER	1
20	50.0176.0.000	FRONT COVER	1
21	50.0177.0.000	BACK COVER	1
22	50.0178.0.800	COVER SIDE	2
23	50.0180.0.800	PLATE	1
24	50.0181.0.990	RUBBER WASHER	1
25	50.0368.0.000	COVER SIDE	1
26	50.0386.0.800	COVER	1
27	03.5550.0.004	KIT ATLAS SINGLE - HANDED SWITCH	1
28	50.9072.0.050	EYE SHIELD - ASSEMBLY	1
29	08.6002.3.025	SCREW M3-25	(1)
30	08.6807.3.100	WASHER 3,2	(2)
31	15.1410.0.992	COVER PLEXI	(1)
32	15.1416.0.902	HINGE LOWER	(1)
33	15.1422.0.100	SCREW M3-5	(2)
34	15.1423.0.100	SCREW M3-10	(2)
35	50.0383.0.600	HINGE UPPER	(1)
40	08.6012.3.006	SCREW M3-6	2
41	50.0087.0.800	BEDPLATE	1
42	50.0088.0.800	BEDPLATE	1
43	50.0089.0.800	BEDPLATE	1
44	08.6202.3.006	SCREW M3-6	4
45	08.6202.3.008	SCREW M3-8	2
46	08.6202.3.010	SCREW M3-10	1
47	12.0010.4.324	LIGHT ATLAS	1
48	50.0189.0.992	COVER LED LIGHT	1

# CLAMPING + AXES X, Y

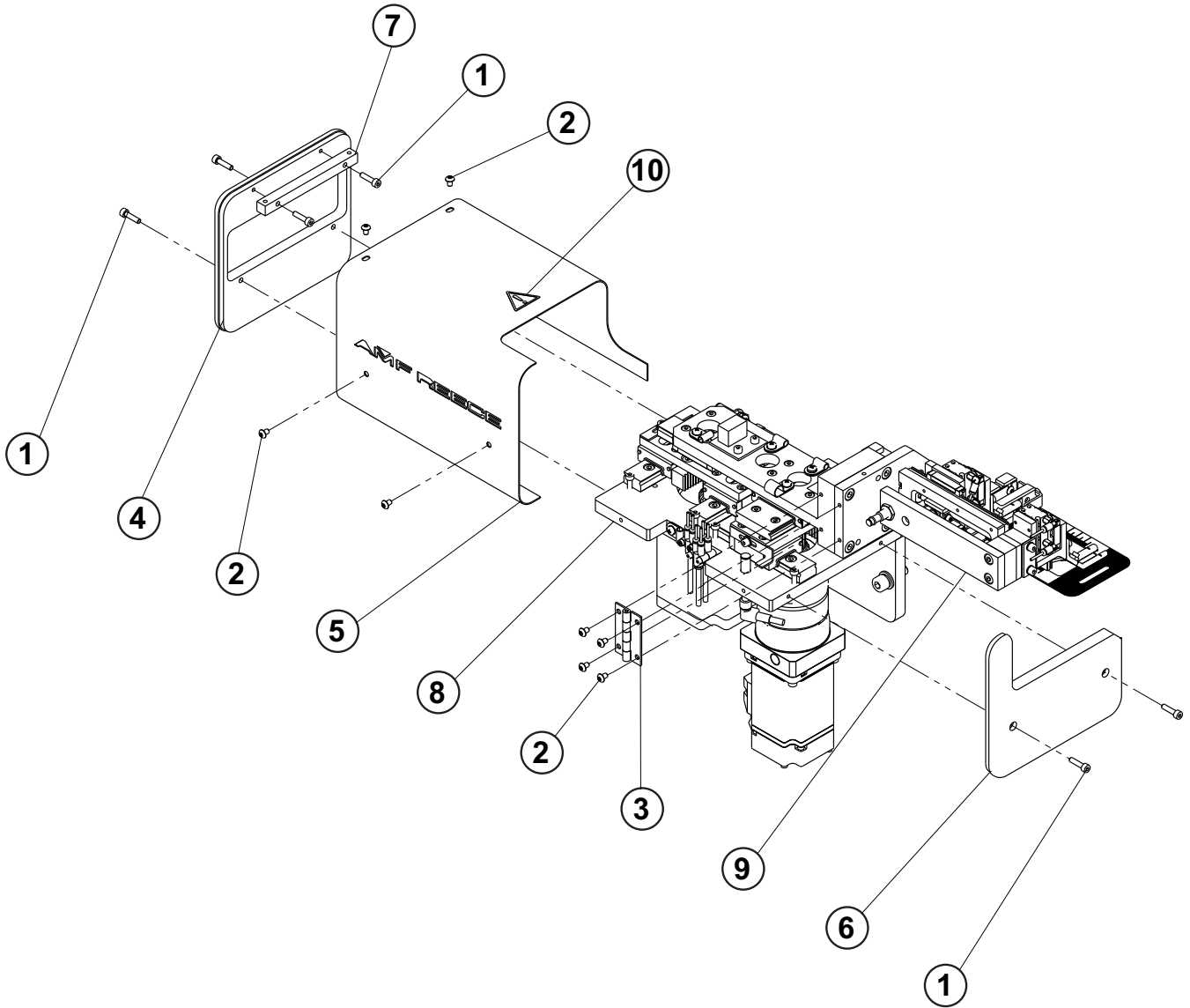

**CLAMPING + AXES X, Y**

<b>DET</b>	<b>PART NUMBER</b>	<b>DESCRIPTION</b>	<b>QTY.</b>
01	08.6002.4.016	SCREW M4-16	6
02	08.6202.4.006	SCREW M4-6	8
03	12.0010.6.231	FLAT HINGES	1
04	50.0170.0.600	COVER	1
05	50.0171.0.800	COVER	1
06	50.0172.0.600	COVER	1
07	50.0423.0.600	BRACKET	1
08	50.9033.0.050	DRIVE AXES X,Y - ASSEMBLY	1
09	50.9034.0.050	CLAMPING LOOP - ASSEMBLY	1
10	17.0097.5.174	LABEL - WARNING	1

# DRIVE AXES X-Y

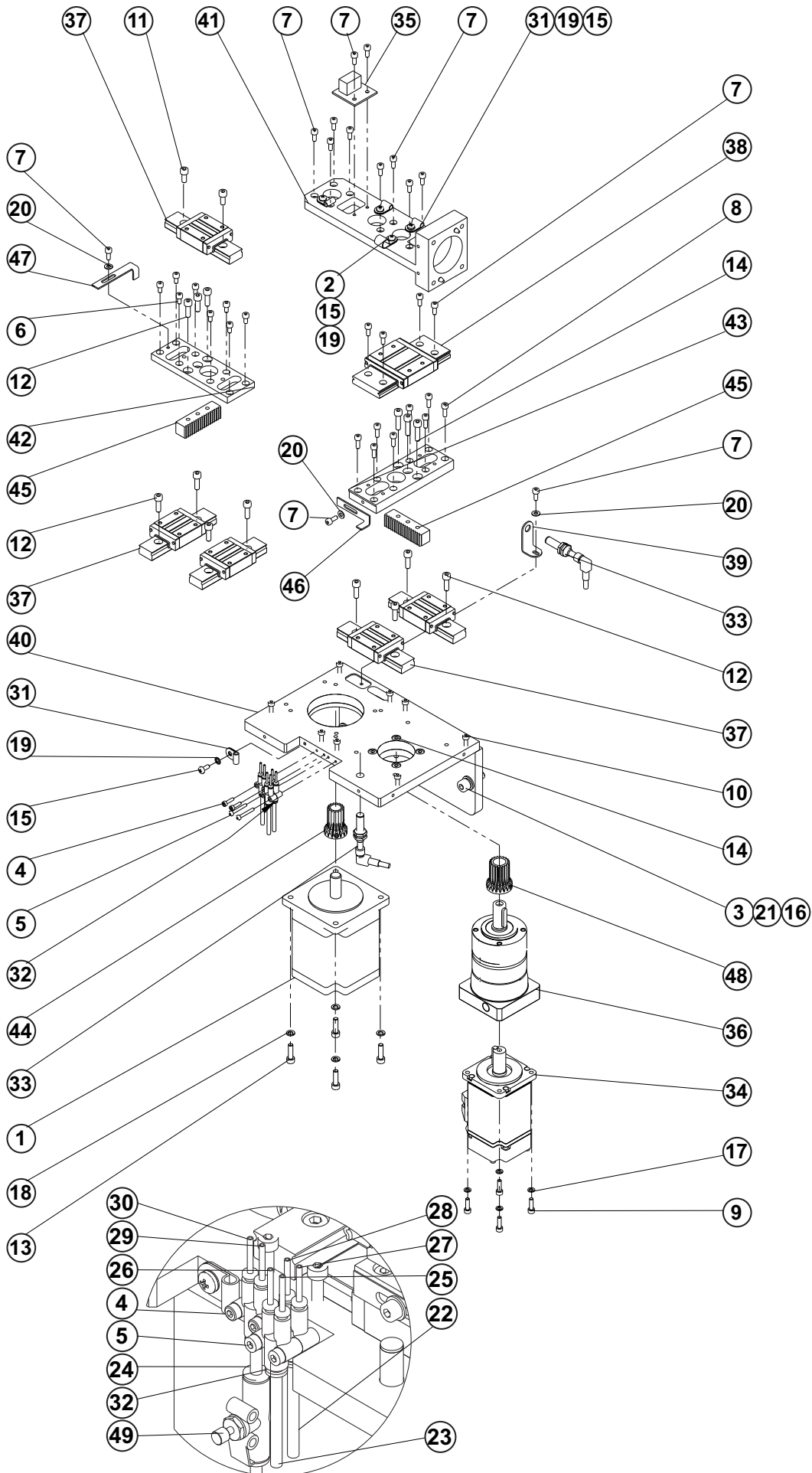

## DRIVE AXES X-Y

DET	PART NUMBER	DESCRIPTION	QTY.
01	06.5000.0.021	STEPPER MOTOR ASSEMBLY - X AXIS	1
02	07.6600.0.004	CLAMP CABLE	1
03	08.6000.8.025	SCREW M8-25	3
04	08.6002.3.012	SCREW M3-12	2
05	08.6002.3.022	SCREW M3-22	2
06	08.6002.4.008	SCREW M4-8	8
07	08.6002.4.010	SCREW M4-10	17
08	08.6002.4.012	SCREW M4-12	8
09	08.6002.4.014	SCREW M4-14	4
10	08.6002.4.020	SCREW M4-20	8
11	08.6002.5.012	SCREW M5-12	2
12	08.6002.5.016	SCREW M5-16	11
13	08.6002.5.018	SCREW M5-18	4
14	08.6002.5.020	SCREW M5-20	7
15	08.6032.4.010	SCREW M4-10	5
16	08.6800.8.000	SPRING WASHER M8	3
17	08.6802.4.000	SPRING WASHER M4	4
18	08.6802.5.000	SPRING WASHER M5	4
19	08.6832.4.000	WASHER M4	5
20	08.6850.4.000	WASHER M4	3
21	08.6850.8.000	WASHER 8	3
22	12.0008.3.416	AIR TUBING - 15A	1
23	12.0008.3.416	AIR TUBING - 15B	1
24	12.0008.3.416	AIR TUBING - 17A	1
25	12.0008.3.749	AIR TUBING - 15A1	1
26	12.0008.3.749	AIR TUBING - 15A2	1
27	12.0008.3.749	AIR TUBING - 15B1	1
28	12.0008.3.749	AIR TUBING - 15B2	1
29	12.0008.3.749	AIR TUBING - 17A1	1
30	12.0008.3.749	AIR TUBING - 17A2	1
31	12.0008.4.277	CLAMP	4
32	12.0010.3.148	CONNECTOR	3
33	12.0010.4.025	SENSOR	2
34	12.0010.4.177	SERVOMOTOR OMRON	1
35	12.0010.4.287	TERMINAL BOARD	1
36	12.0010.6.230	PLANETARY GEAR	1
37	12.2070.1.048	GUIDE	5
38	12.2070.1.049	SEBWV16-110	1
39	15.1123.0.800	SENSOR BRACKET	1
40	50.0190.0.000	HOLDER MOTOR	1
41	50.0191.0.000	HOLDER	1
42	50.0192.0.600	PLATE	1
43	50.0193.0.600	PLATE	1
44	50.0194.0.500	GEAR z16	1
45	50.0195.0.600	RACK	2
46	50.0196.0.800	SENSOR PLATE	1
47	50.0197.0.800	SENSOR PLATE	1
48	50.0199.0.500	GEAR z20	1
49	12.0010.3.029	SPEED VALVE	1

# CLAMPING LOOP

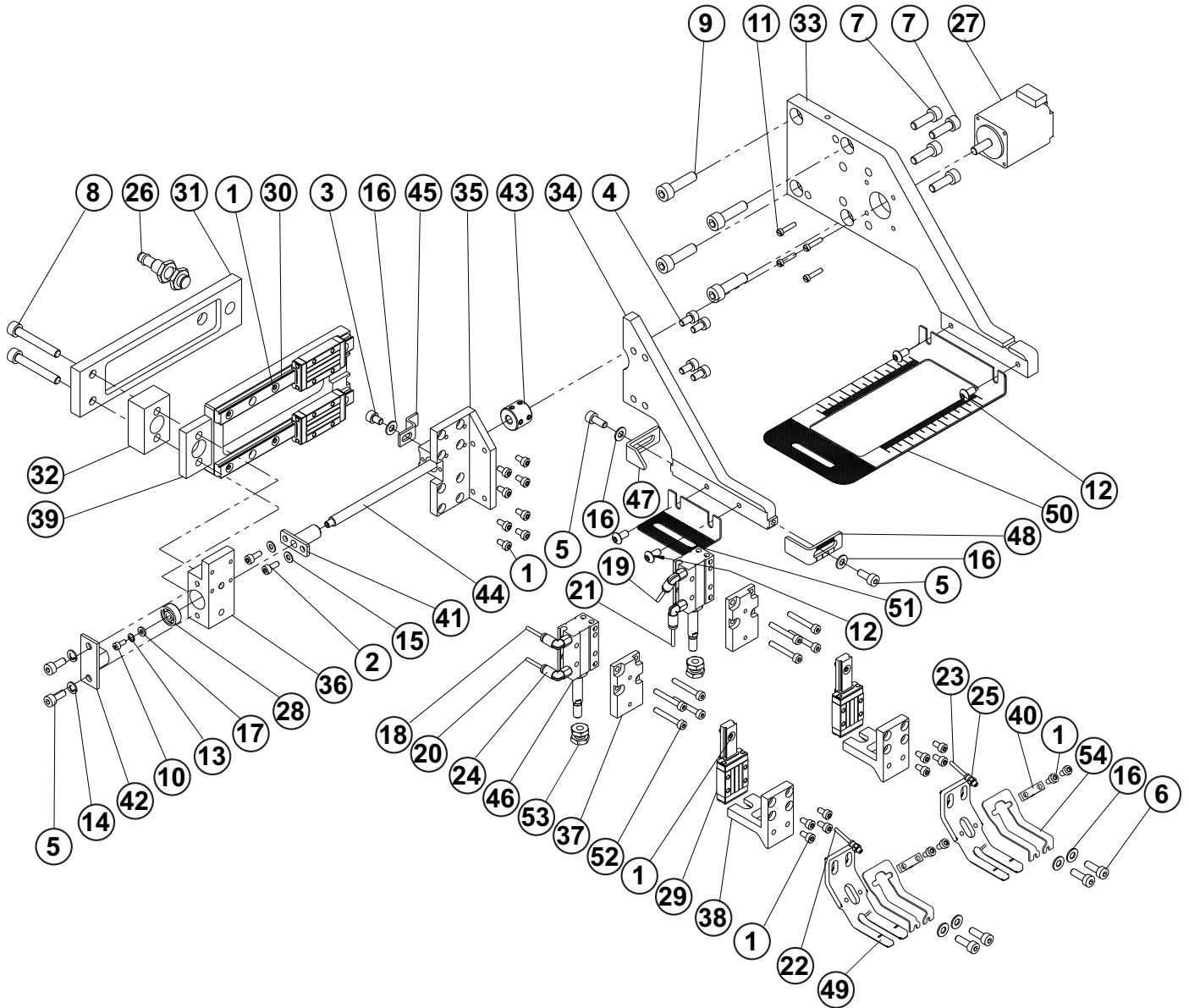

## CLAMPING LOOP

DET	PART NUMBER	DESCRIPTION	QTY.
01	08.6002.3.006	SCREW M3-6	30
02	08.6002.3.008	SCREW M3-8	2
03	08.6002.4.006	SCREW M4-6	1
04	08.6002.4.008	SCREW M4-8	4
05	08.6002.4.010	SCREW M4-10	4
06	08.6002.4.012	SCREW M4-12	4
07	08.6002.5.016	SCREW M5-16	4
08	08.6002.5.035	SCREW M5-35	2
09	08.6002.6.022	SCREW M6-20	4
10	08.6002.7.006	SCREW M2,5-6	1
11	08.6012.7.012	SCREW M2,5-12	4
12	08.6202.4.008	SCREW M4-8	4
13	08.6802.3.000	SPRING WASHER M3	1
14	08.6802.4.000	SPRING WASHER M4	2
15	08.6852.3.000	WASHER M3	2
16	08.6852.4.000	WASHER M4	7
17	08.6887.3.000	WASHER 1x3x6	1
18	12.0008.3.749	AIR TUBING - 15A1	1
19	12.0008.3.749	AIR TUBING - 15A2	1
20	12.0008.3.749	AIR TUBING - 15B1	1
21	12.0008.3.749	AIR TUBING - 15B2	1
22	12.0008.3.749	AIR TUBING - 17A1	1
23	12.0008.3.749	AIR TUBING - 17A2	1
24	12.0010.3.072	CONNECTOR	4
25	12.0010.3.187	CONNECTOR	2
26	12.0010.4.093	SENSOR BQ	1
27	12.0010.4.276	MOTOR	1
28	12.2010.0.019	BEARING	1
29	12.2070.1.054	GUIDE	2
30	12.2070.1.060	GUIDE	2
31	50.0210.0.600	PLATE	1
32	50.0211.0.600	SPACER BLOCK	1
33	50.0212.0.600	HOLDER BEDPLATE	1
34	50.0213.0.600	HOLDER BEDPLATE	1
35	50.0214.0.600	RIDER	1
36	50.0215.0.600	BLOCK	1
37	50.0216.0.600	PLATE	2
38	50.0217.0.600	HOLDER	2
39	50.0218.0.600	PLATE	1
40	50.0220.0.600	HOLDER	2
41	50.0221.0.600	NUT	1
42	50.0224.0.600	HOLDER	1
43	50.0227.0.400	COUPLING	1
44	50.0228.0.300	ENDLESS SCREW	1
45	50.0229.1.800	SENSOR PLATE	1
46	50.0232.0.000	CYLINDER	2

# CLAMPING LOOP

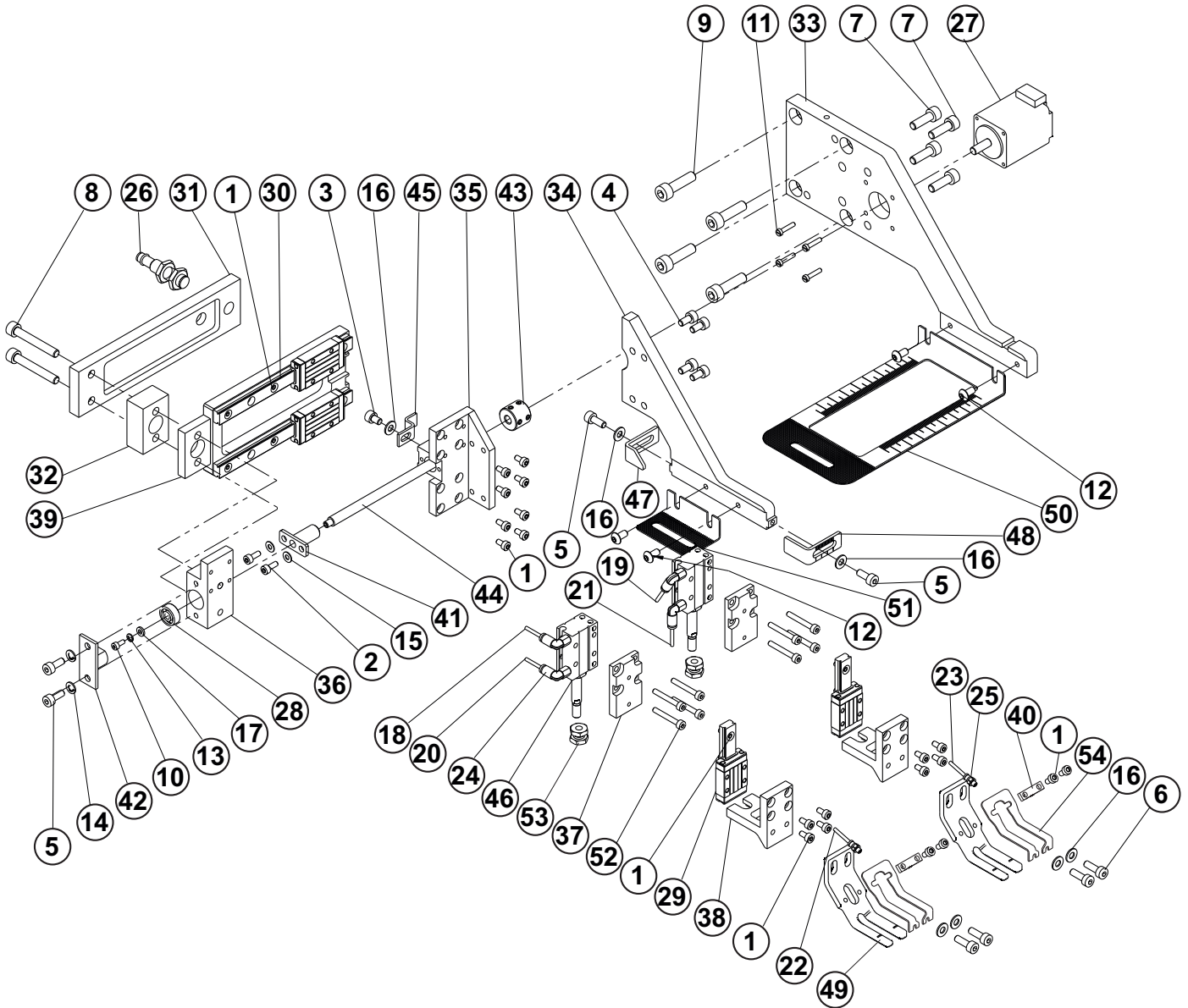



**CLAMPING LOOP**

DET	PART NUMBER	DESCRIPTION	QTY.
47	50.0234.0.800	STOP	1
48	50.0235.0.800	STOP	1
49	50.9902.0.804	CLAMP FOOT - 6 <span style="float: right;">See page 3 - 96</span>	2
50	50.9903.0.801	BEDPLATE FIXED - 6 <span style="float: right;">See page 3 - 96</span>	1
51	50.9904.0.801	BEDPLATE SLIDING - 6 <span style="float: right;">See page 3 - 96</span>	1
52	08.6002.3.022	SCREW M3-22	8
53	50.0219.0.100	NUT M5	4
54	50.9920.0.801	FLEXIBLE STOP	2

CUTTING

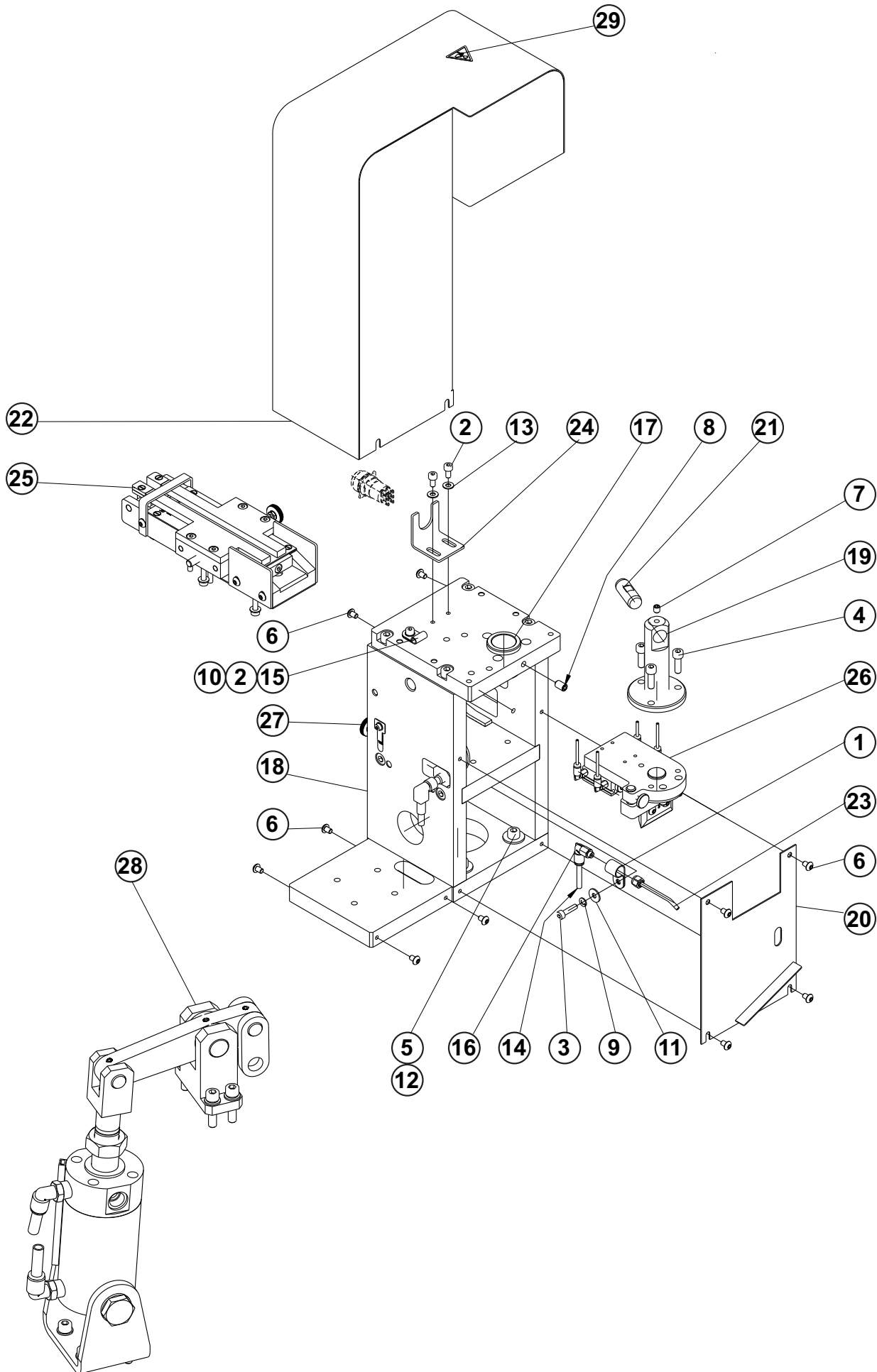

**CUTTING**

DET	PART NUMBER	DESCRIPTION	QTY.
01	07.6600.0.004	CLAMP CABLE	1
02	08.6002.4.008	SCREW M4-8	3
03	08.6002.4.016	SCREW M4-16	1
04	08.6002.5.016	SCREW M5-16	3
05	08.6002.6.022	SCREW M6-20	4
06	08.6200.4.006	SCREW M4-6	11
07	08.6400.5.006	SCREW M5-6	1
08	08.6400.6.010	SCREW M6-10	1
09	08.6802.4.000	SPRING WASHER M4	1
10	08.6832.4.000	WASHER M4	1
11	08.6842.4.000	WASHER 4	1
12	08.6842.6.000	WASHER M6	4
13	08.6852.4.000	WASHER M4	2
14	12.0008.3.416	AIR TUBING - 13A	1
15	12.0008.4.277	CLAMP	1
16	12.0010.3.028	CONNECTOR	1
17	50.0257.0.400	BUSHING	1
18	50.0260.0.000	CUTTING FRAME	1
19	50.0266.0.300	CUTTER DRIVING SHAFT	1
20	50.0275.0.800	COVER	1
21	50.0327.0.300	PIN	1
22	50.0366.0.000	COVER	1
23	50.0381.0.000	TUBE	1
24	50.0382.0.800	HOLDER	1
25	50.9052.1.050	CUTTING STEEL - ASSEMBLY	1
26	50.9053.0.050	HOLER KNIFE - ASSEMBLY	1
27	50.9054.0.050	DETECTION LOOPS - ASSEMBLY	1
28	50.9070.0.050	CUTTING LEVER - ASSEMBLY	1
29	12.8000.0.409	LABEL	1

# CUTTING LEVER

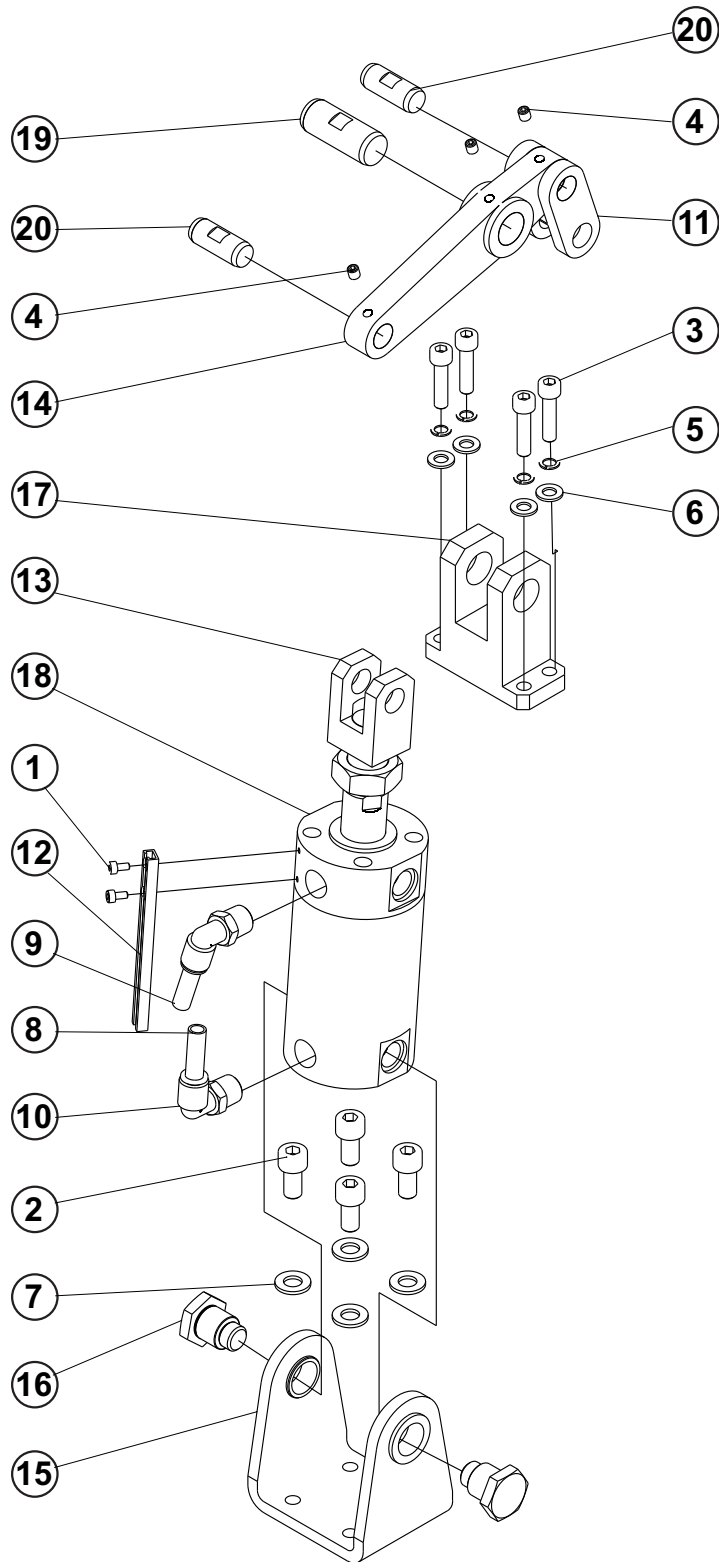



# CUTTING STEEL

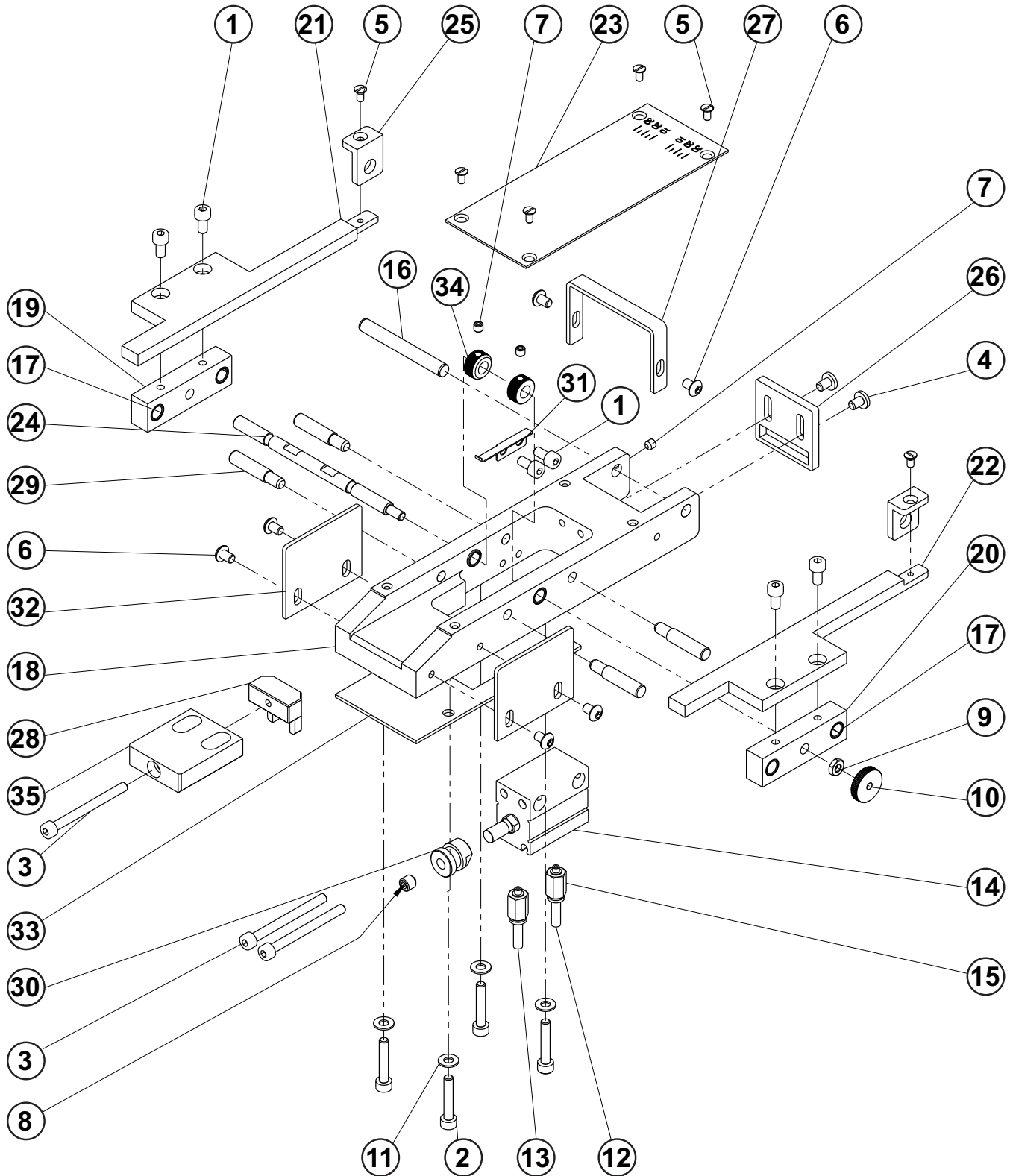

## CUTTING STEEL

DET	PART NUMBER	DESCRIPTION	QTY.
01	08.6002.4.008	SCREW M4-8	6
02	08.6002.4.022	SCREW M4-22	4
03	08.6002.4.045	SCREW M4-45	3
04	08.6050.4.006	SCREW M4-6	2
05	08.6112.3.006	SCREW M3-6	6
06	08.6202.4.006	SCREW M4-6	6
07	08.6400.4.004	SCREW M4-4	3
08	08.6400.6.006	SCREW M6-6	1
09	08.6712.4.000	NUT M4	1
10	08.6772.4.000	NUT M4	1
11	08.6852.4.000	WASHER M4	4
12	12.0008.3.416	AIR TUBE	1
13	12.0008.3.416	AIR TUBE	1
14	12.0010.3.044	CYLINDER	1
15	12.0010.3.119	CONNECTOR	2
16	12.1010.2.024	PIN 6h6-50	1
17	12.2080.0.020	BEARING	6
18	50.0236.1.600	CUTTING BLOCK	1
19	50.0237.1.600	SIDE GUIDE - LEFT	1
20	50.0238.1.600	SIDE GUIDE - RIGHT	1
21	50.0239.0.600	SIDE GUIDE - LEFT	1
22	50.0240.0.600	SIDE GUIDE - RIGHT	1
23	50.0241.0.800	GUIDE PLATE	1
24	50.0242.0.300	SHAFT	1
25	50.0243.0.600	GUIDE	2
26	50.0244.0.800	LOOP GUIDE	1
27	50.0245.0.800	GUIDE	1
28	50.0246.1.600	RIDER	1
29	50.0247.1.300	GUIDE	4
30	50.0248.1.300	NUT	1
31	50.0254.0.800	SPRING	1
32	50.0272.0.800	SIDE COVER	2
33	50.0290.0.990	RUBBER WASHER	1
34	50.0388.0.400	RING	2
35	50.9905.1.601	CUTTING STEEL	1

# HOLER KNIFE

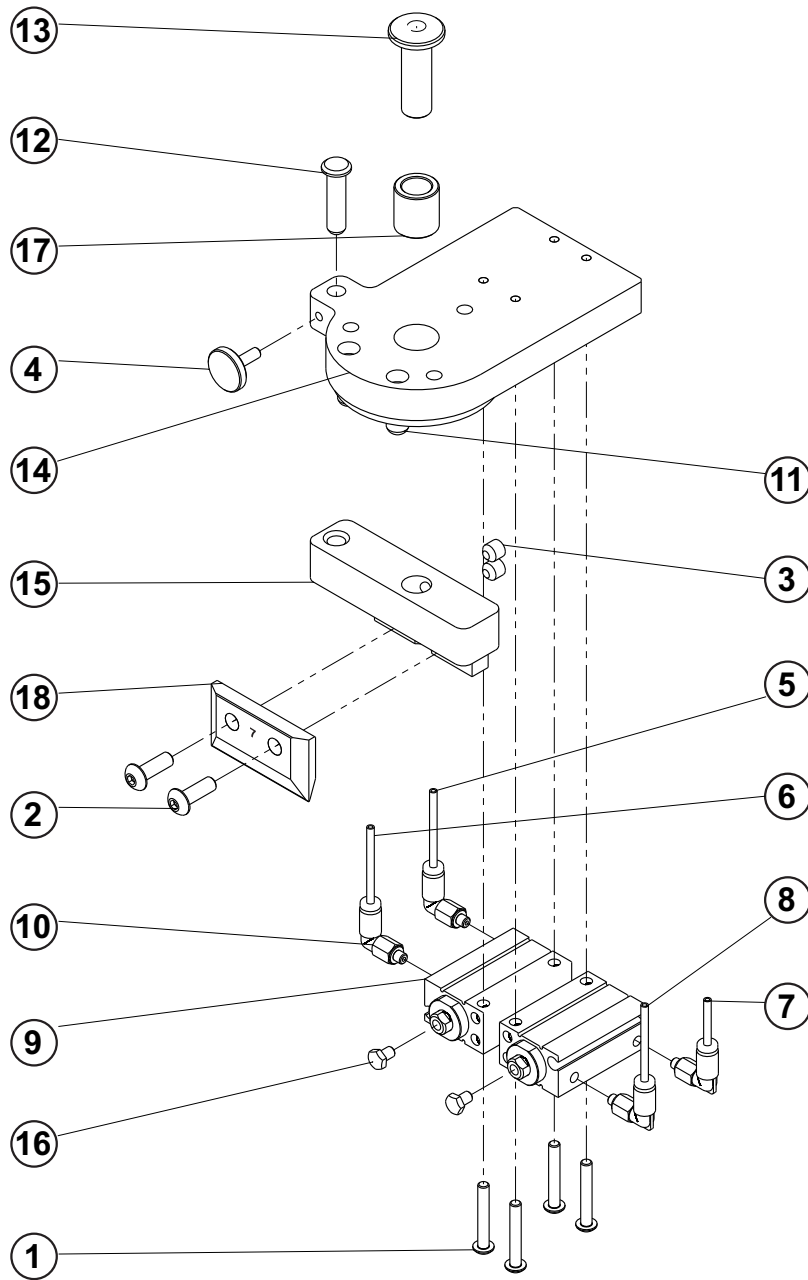



**HOLER KNIFE**

DET	PART NUMBER	DESCRIPTION	QTY.
01	08.6202.3.008	SCREW M3-20	4
02	08.6202.4.010	SCREW M4-10	2
03	08.6400.5.005	SCREW M5-5	2
04	08.6552.3.010	SCREW M3-10	1
05	12.0008.3.749	AIR TUBING - 11A	1
06	12.0008.3.749	AIR TUBING - 11B	1
07	12.0008.3.749	AIR TUBING - 12A	1
08	12.0008.3.749	AIR TUBING - 12B	1
09	12.0008.3.866	CYLINDER	2
10	12.0010.3.072	CONNECTOR	4
11	12.1010.0.614	PIN 6-14	2
12	50.0222.0.300	STUD 5x20	1
13	50.0249.0.300	CUTTING HEAD PIN	1
14	50.0250.0.600	PLATE	1
15	50.0251.0.600	KNIFE HOLDER	1
16	50.0252.0.100	STOP SCREW	2
17	50.0253.0.400	BUSHING	1
18	50.9906.0.602	KNIFE 7	1
		See page 3 - 97	

# HOLER LOOP

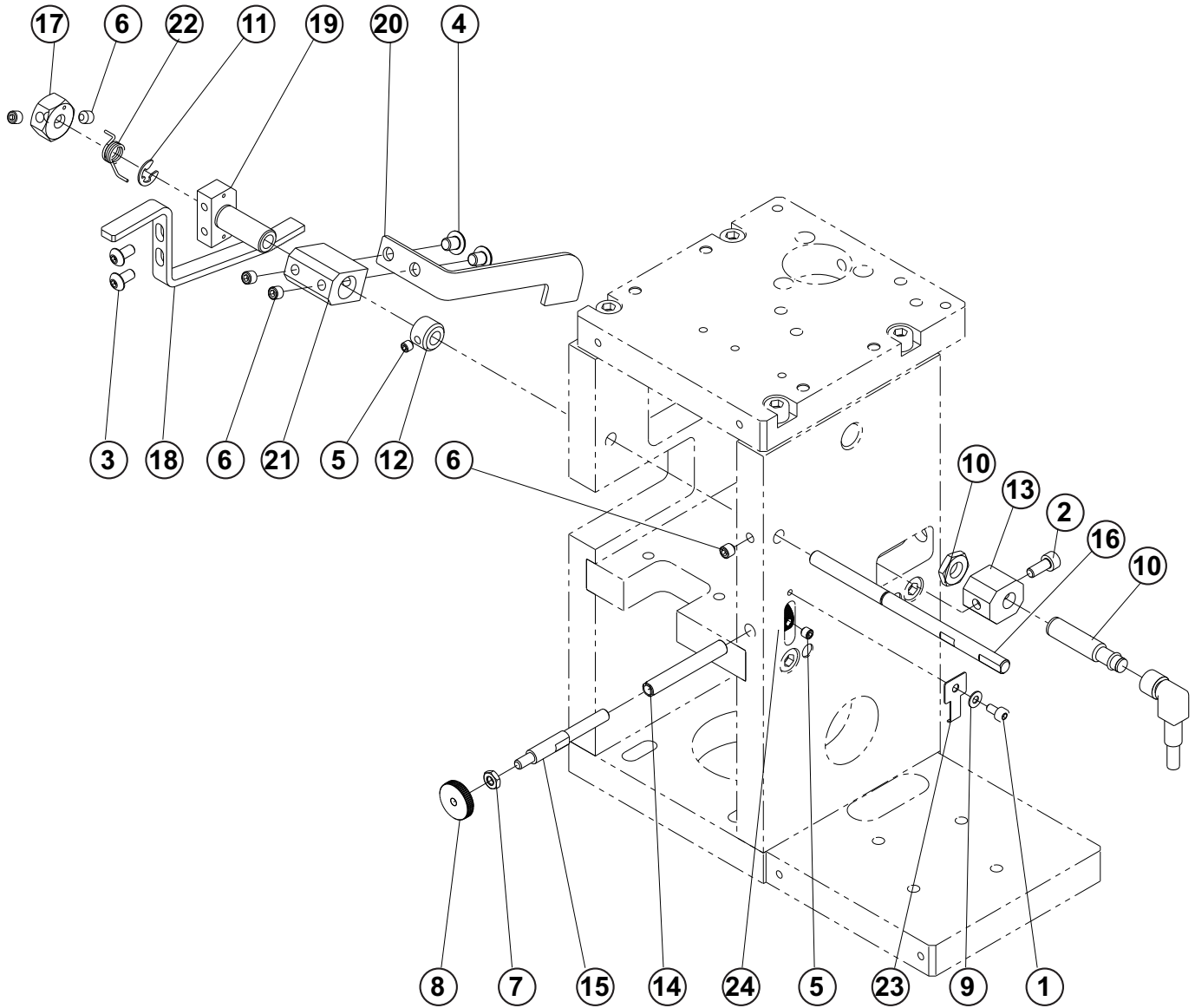

**HOLER LOOP**

DET	PART NUMBER	DESCRIPTION	QTY.
01	08.6002.3.006	SCREW M3-6	1
02	08.6002.4.010	SCREW M4-10	1
03	08.6202.4.008	SCREW M4-8	2
04	08.6202.5.006	SCREW M5x6	2
05	08.6400.4.004	SCREW M4-4	2
06	08.6400.5.005	SCREW M5-5	5
07	08.6712.4.000	NUT M4	1
08	08.6772.4.000	NUT M4	1
09	08.6852.3.000	WASHER M3	1
10	12.0010.4.093	SENSOR BQ 5	1
11	12.1045.0.005	RETAINING RING 5	1
12	12.1050.0.002	CLAMP COLLAR 6	1
13	50.0261.0.600	SENSOR BRACKET	1
14	50.0262.0.300	ROD	1
15	50.0264.0.300	SCREW	1
16	50.0269.0.300	SHAFT	1
17	50.0271.0.300	TENSIONING NUT	1
18	50.0273.0.800	LOOP CONNECTION FEELER	1
19	50.0274.0.600	LOOP FEELER HOLDER	1
20	50.0276.0.800	SENSOR PLATE	1
21	50.0376.0.600	LOOP FEELER HOLDER	1
22	50.0378.0.200	TORSION SPRING	1
23	50.0402.0.800	SPRING	1
24	50.0409.0.400	RING	1

# LOADER MECHANISM AXIS X

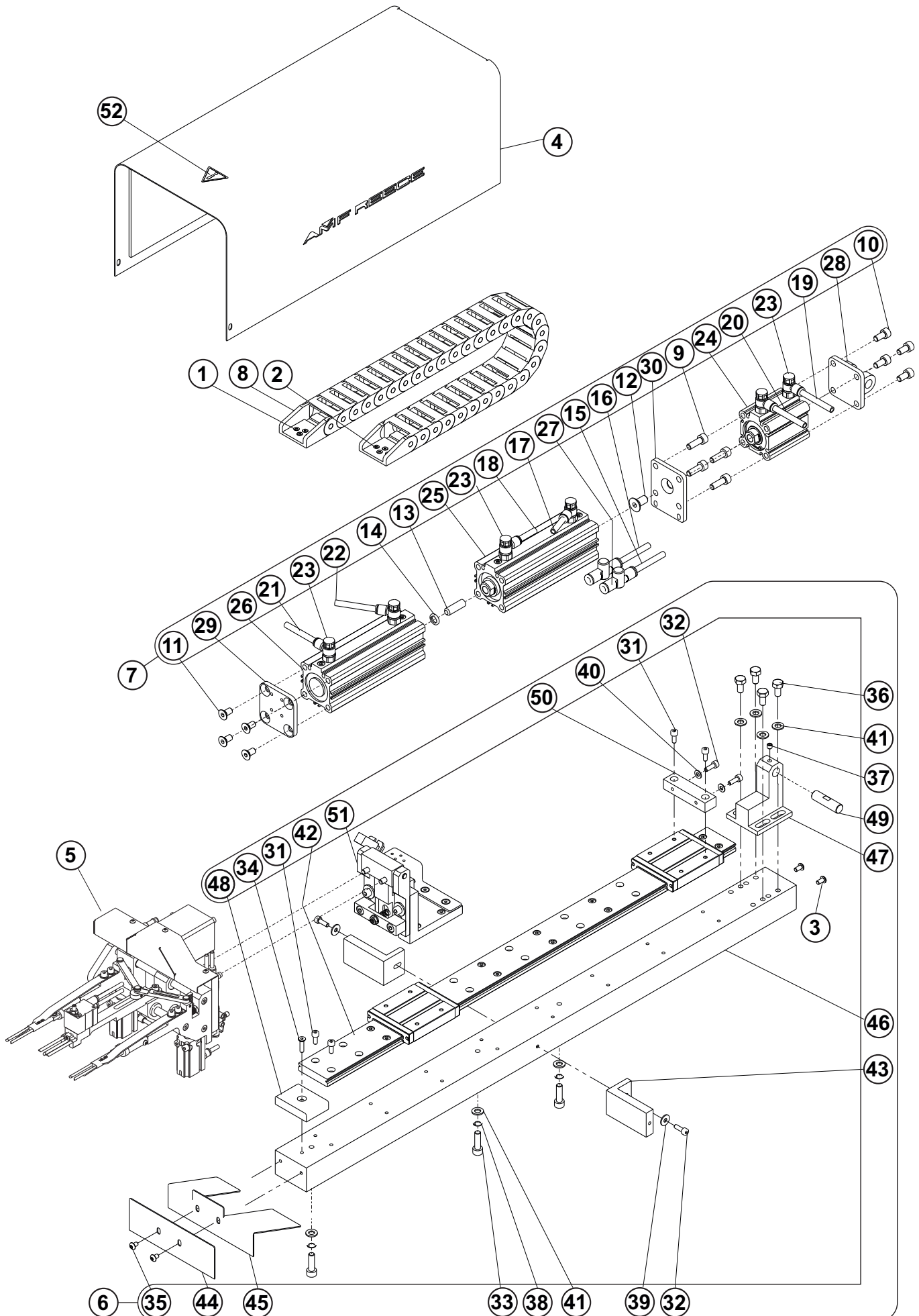

## LOADER MECHANISM AXIS X

DET	PART NUMBER	DESCRIPTION	QTY.
01	08.6132.3.005	SCREW M3-5	4
02	08.6133.3.008	SCREW M3-8	4
03	08.6202.4.008	SCREW M4-8	4
04	50.0367.0.000	COVER	1
05	50.9056.0.050	FEED HEAD - ASSEMBLY	1
06	50.9060.0.050	BASE OSA X	1
07	50.9061.0.050	PNEUMATIC CYLINDERS - ASSEMBLY	1
08	12.0010.6.923	ENERGY CHAIN EC15 + 2x END	1
09	08.6000.6.018	SCREW M6-18	(4)
10	08.6002.6.012	SCREW M6-12	(4)
11	08.6102.6.012	SCREW M6-12	(4)
12	08.6102.8.016	SCREW M8-16	(1)
13	08.6400.8.025	SCREW M8-25	(1)
14	08.6800.8.000	SPRING WASHER M8	(1)
15	12.0008.3.415	AIR TUBING - 4A	(1)
16	12.0008.3.415	AIR TUBING - 4B	(1)
17	12.0008.3.415	AIR TUBING - 4A1	(1)
18	12.0008.3.415	AIR TUBING - 4B1	(1)
19	12.0008.3.415	AIR TUBING - 5A	(1)
20	12.0008.3.415	AIR TUBING - 5B	(1)
21	12.0008.3.415	AIR TUBING - 10A	(1)
22	12.0008.3.415	AIR TUBING - 10B	(1)
23	12.0010.3.043	SPEED VALVE	(6)
24	12.0010.3.200	CYLINDER	(1)
25	12.0010.3.201	CYLINDER	(1)
26	12.0010.3.202	CYLINDER	(1)
27	12.0010.3.203	QUICK EXHAUST VALVE	(2)
28	50.0281.0.600	HOLDER	(1)
29	50.0284.0.800	HOLDER	(1)
30	50.0288.0.800	HOLDER	(1)
31	08.6002.4.010	SCREW M4-10	(18)
32	08.6002.4.012	SCREW M4-12	(4)
33	08.6002.6.020	SCREW M6-20	(3)
34	08.6102.4.016	SCREW M4-16	(1)
35	08.6202.4.006	SCREW M4-6	(2)
36	08.6312.6.012	SCREW M6-12	(4)
37	08.6400.5.005	SCREW M5-5	(1)
38	08.6802.6.000	SPRING WASHER M6	(3)
39	08.6842.4.000	WASHER 4	(2)
40	08.6852.4.000	WASHER M4	(2)
41	08.6852.6.000	WASHER 6,4	(7)
42	12.2070.1.053	GUIDE	(1)
43	50.0277.0.600	HOLDER COVER	(2)
44	50.0278.0.800	COVER	(1)
45	50.0279.0.800	COVER	(1)
46	50.0280.0.600	BASE - PLATE	(1)

# LOADER MECHANISM AXIS X

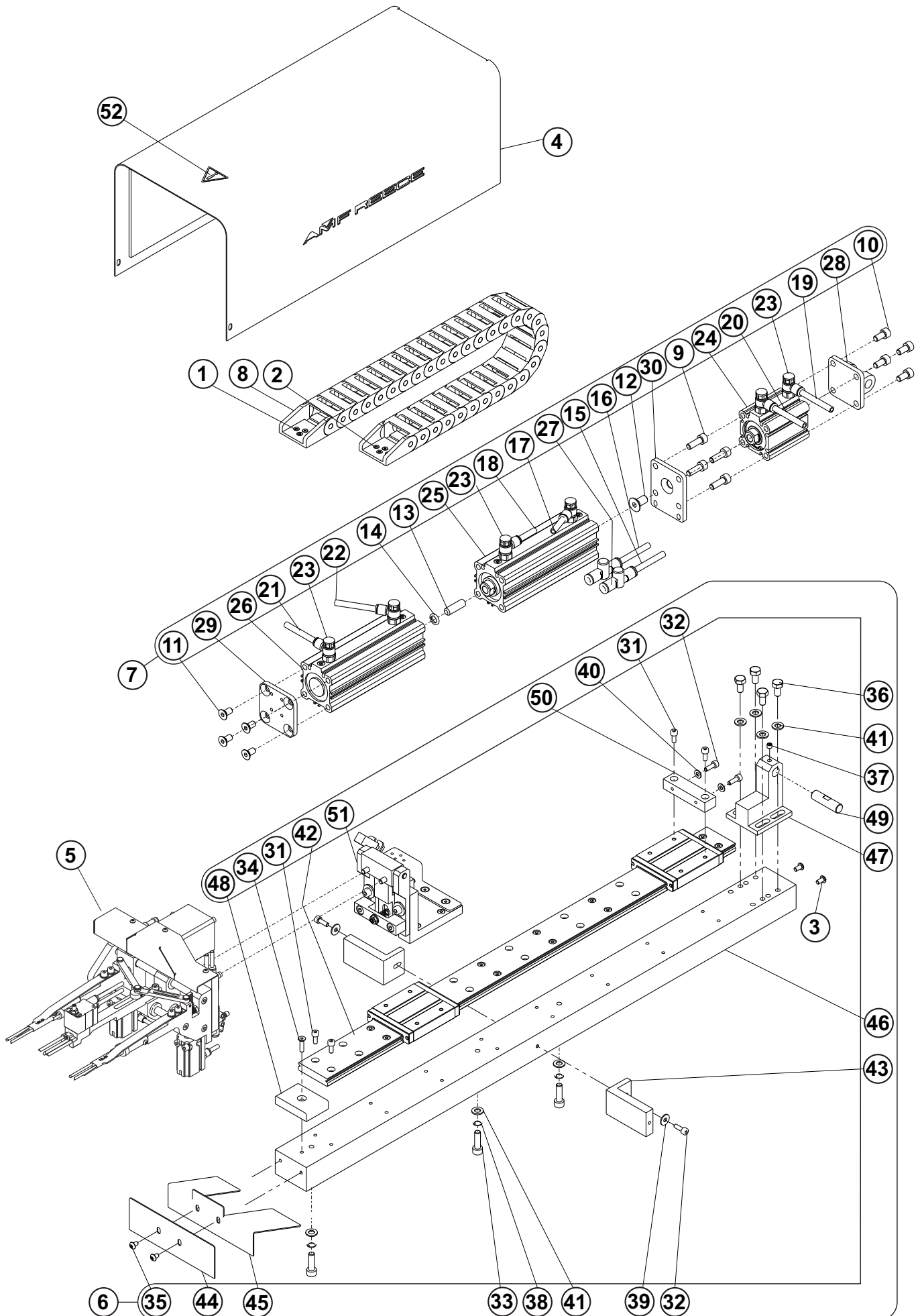

## LOADER MECHANISM AXIS X

DET	PART NUMBER	DESCRIPTION	QTY.
47	50.0282.0.600	HOLDER	(1)
48	50.0286.0.600	STOP	(1)
49	50.0309.0.300	STUD 10-36	(1)
50	50.0310.0.600	BLOCK	(1)
51	50.9069.0.050	RIDER - ASSEMBLY	(1)
52	17.0097.5.174	LABEL - WARNING	1

# FEED HEAD

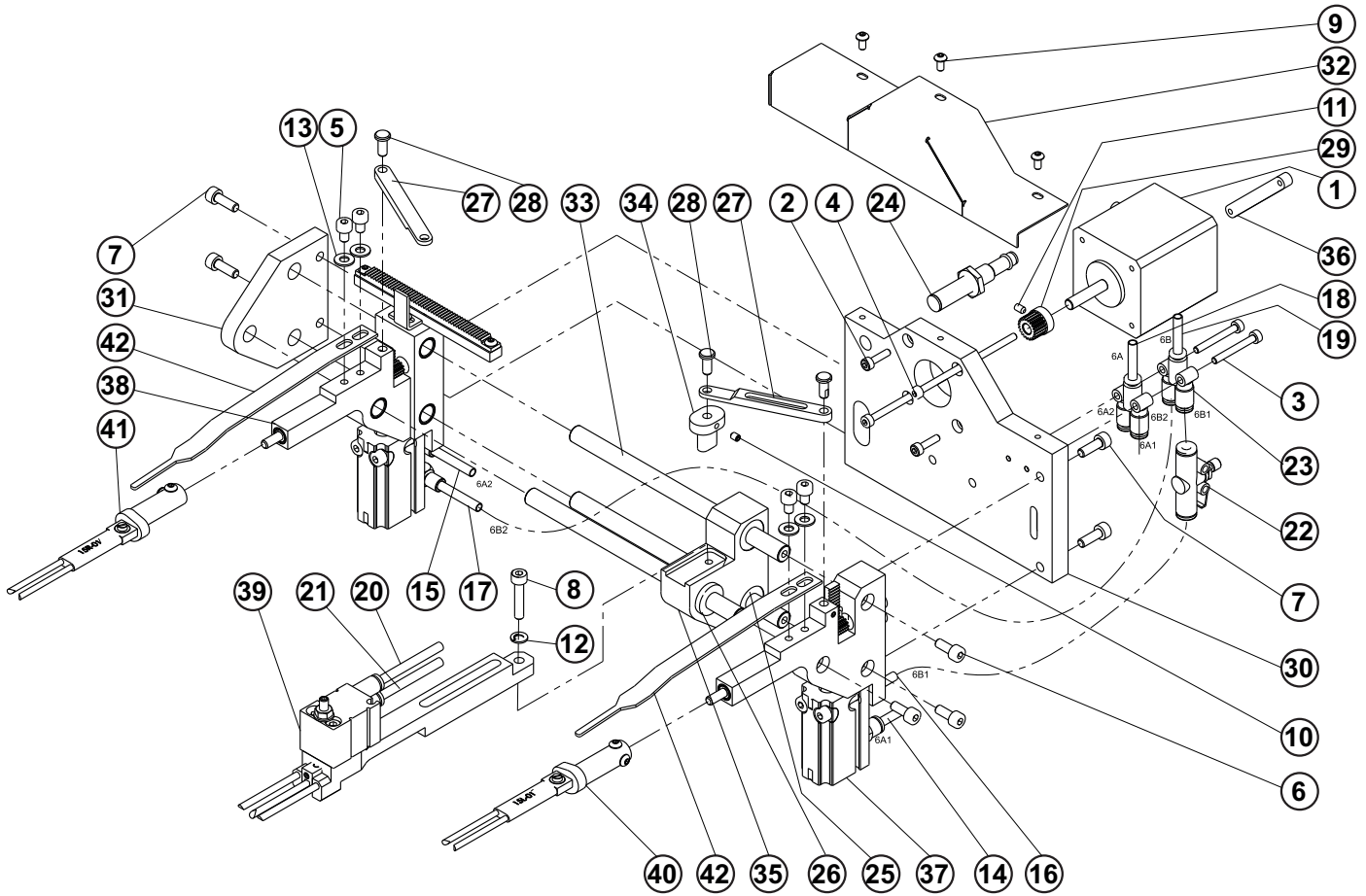



## FEED HEAD

DET	PART NUMBER	DESCRIPTION	QTY.
01	06.5000.0.026	STEPPER MOTOR SM6	1
02	08.6002.3.012	SCREW M3-12	2
03	08.6002.3.025	SCREW M3-25	2
04	08.6002.3.060	SCREW M3-60	2
05	08.6002.4.006	SCREW M4-6	4
06	08.6002.4.010	SCREW M4-10	3
07	08.6002.4.012	SCREW M4-12	4
08	08.6002.4.020	SCREW M4-20	1
09	08.6202.3.006	SCREW M3-6	3
10	08.6400.3.004	SCREW M3-4	1
11	08.6400.3.005	SCREW M3-5	1
12	08.6802.4.000	SPRING WASHER M4	1
13	08.6852.4.000	WASHER M4	4
14	12.0008.3.416	AIR TUBE- 6A1	1
15	12.0008.3.416	AIR TUBE- 6A2	1
16	12.0008.3.416	AIR TUBE- 6B1	1
17	12.0008.3.416	AIR TUBE- 6B2	1
18	12.0008.3.416	AIR TUBE- 6A	1
19	12.0008.3.416	AIR TUBE- 6B	1
20	12.0008.3.416	AIR TUBING - 7A	1
21	12.0008.3.416	AIR TUBING - 7B	1
22	12.0010.3.029	SPEED VALVE	1
23	12.0010.3.037	CONNECTOR	2
24	12.0010.4.025	SENSOR	1
25	12.2070.0.023	LINEAR BEARING LMUT8	2
26	12.2070.0.024	LINEAR BEARING LMUF8	1
27	50.0292.0.600	CONNECTING ROD	2
28	50.0293.0.300	STUD 4x9,5	3
29	50.0294.0.500	GEAR z20	1
30	50.0295.0.600	BASE PLATE	1
31	50.0296.0.600	HOLDER	1
32	50.0302.0.800	COVER	1
33	50.0303.0.300	GUIDE ROD	3
34	50.0305.0.600	GUIDE	1
35	50.0306.0.600	CENTRAL BLOCK	1
36	50.0307.0.600	BRACKET	1
37	50.9058.0.050	FIXED ARM - ASSEMBLY	1
38	50.9059.0.050	FLEXIBLE ARM - ASSEMBLY	1
39	50.9082.0.050	CENTRAL ARM S5 - ASSEMBLY	See page 3 - 97 1
40	50.9085.0.050	FORK 15L-01 - ASSEMBLY	See page 3 - 97 1
41	50.9086.0.050	FORK 15R-01 - ASSEMBLY	See page 3 - 97 1
42	50.9917.0.801	CLOTH PRESSER FOOT	2

# CENTRAL ARM

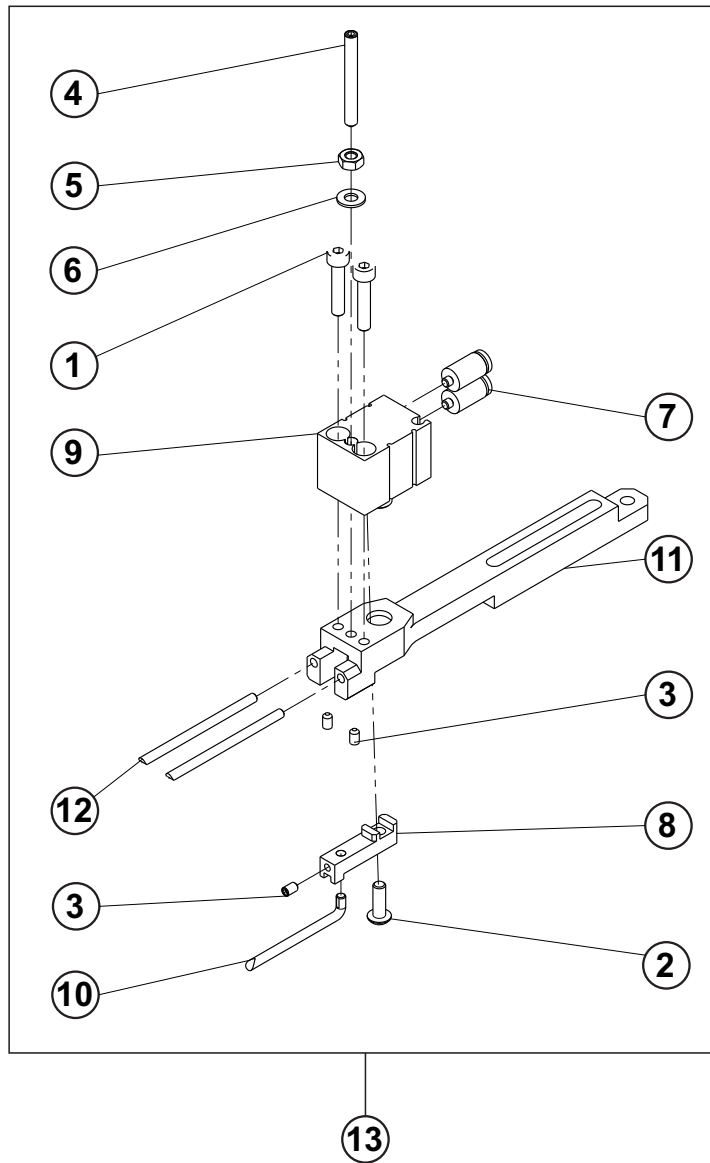



# FIXED ARM

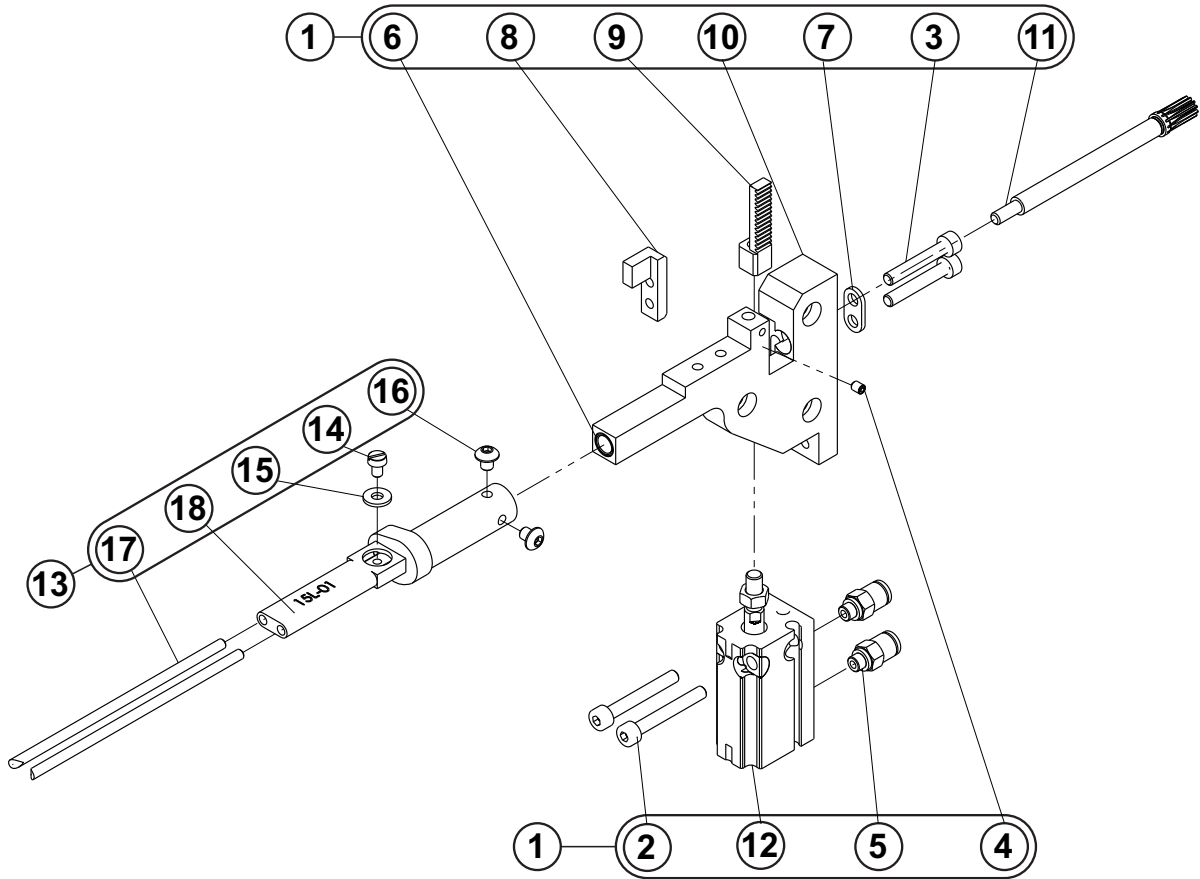

**FIXED ARM**

DET	PART NUMBER	DESCRIPTION	QTY.
01	50.9058.0.050	FIXED ARM	1
02	08.6000.4.030	SCREW M4-30	(2)
03	08.6002.4.025	SCREW M4-25	(2)
04	08.6400.3.004	SCREW M3-4	(1)
05	12.0008.3.409	CONNECTOR	(2)
06	50.0421.0.400	BUSHING 6/8 - 10	(2)
07	50.0299.0.800	WASHER	(1)
08	50.0316.0.600	STOP - RIGHT	(1)
09	50.0317.0.600	RACK	(1)
10	50.0318.1.600	FIXED ARM	(1)
11	50.0319.0.500	GEAR z12	(1)
12	50.0328.0.000	CYLINDER	(1)
13	50.9085.0.050	FORK 15L-01 <span style="float: right;">See page 3 - 97</span>	1
14	08.6012.7.004	SCREW M2,5-4	(1)
15	50.0379.0.400	WASHER 2,5	(1)
16	50.0435.0.100	SCREW M3-3,5	(2)
17	50.9907.0.204	FORK 2,5 - 70	(2)
18	50.9919.0.601	FINGER ROTARY SUPPORT 15L-01	(1)

# FLEXIBLE ARM

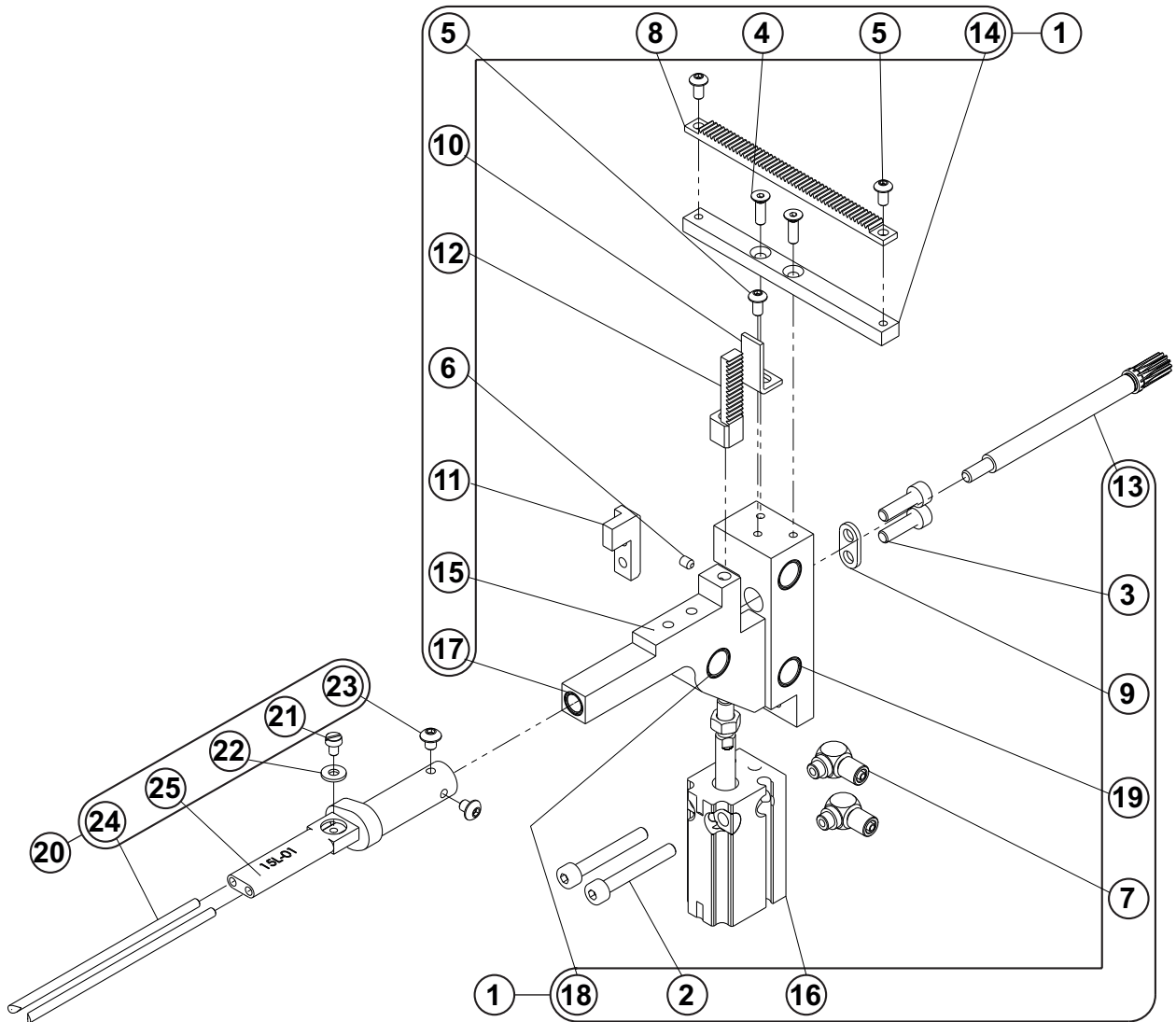

**FLEXIBLE ARM**

DET	PART NUMBER	DESCRIPTION	QTY.
01	50.9059.0.050	FLEXIBLE ARM	1
02	08.6000.4.030	SCREW M4-30	(2)
03	08.6002.4.014	SCREW M4-14	(2)
04	08.6100.3.010	SCREW M3-10	(2)
05	08.6202.3.006	SCREW M3-6	(3)
06	08.6400.3.004	SCREW M3-4	(1)
07	12.0008.3.798	CONNECTOR	(2)
08	50.0297.0.600	RACK	(1)
09	50.0299.0.800	WASHER	(1)
10	50.0301.0.800	SENSOR PLATE	(1)
11	50.0315.0.600	STOP - LEFT	(1)
12	50.0317.0.600	RACK	(1)
13	50.0319.0.500	GEAR z12	(1)
14	50.0320.0.600	HOLDER	(1)
15	50.0325.1.600	FLEXIBLE ARM	(1)
16	50.0328.0.000	CYLINDER CU16-15D	(1)
17	50.0421.0.400	BUSHING 6/8 - 10	(2)
18	50.0314.0.400	BUSHING 8/10 - 22	(1)
19	50.0420.0.400	BUSHING 8/10 - 25	(2)
20	50.9085.0.050	FORK 15R-01	1
		See page 3 - 97	
21	08.6012.7.004	SCREW M2,5-4	(1)
22	50.0379.0.400	WASHER 2,5	(1)
23	50.0435.0.100	SCREW M3-3,5	(2)
24	50.9907.0.204	FORK 2,5 - 70	(2)
25	50.9919.0.601	FINGER ROTARY SUPPORT 15L-01	(1)

# RIDER

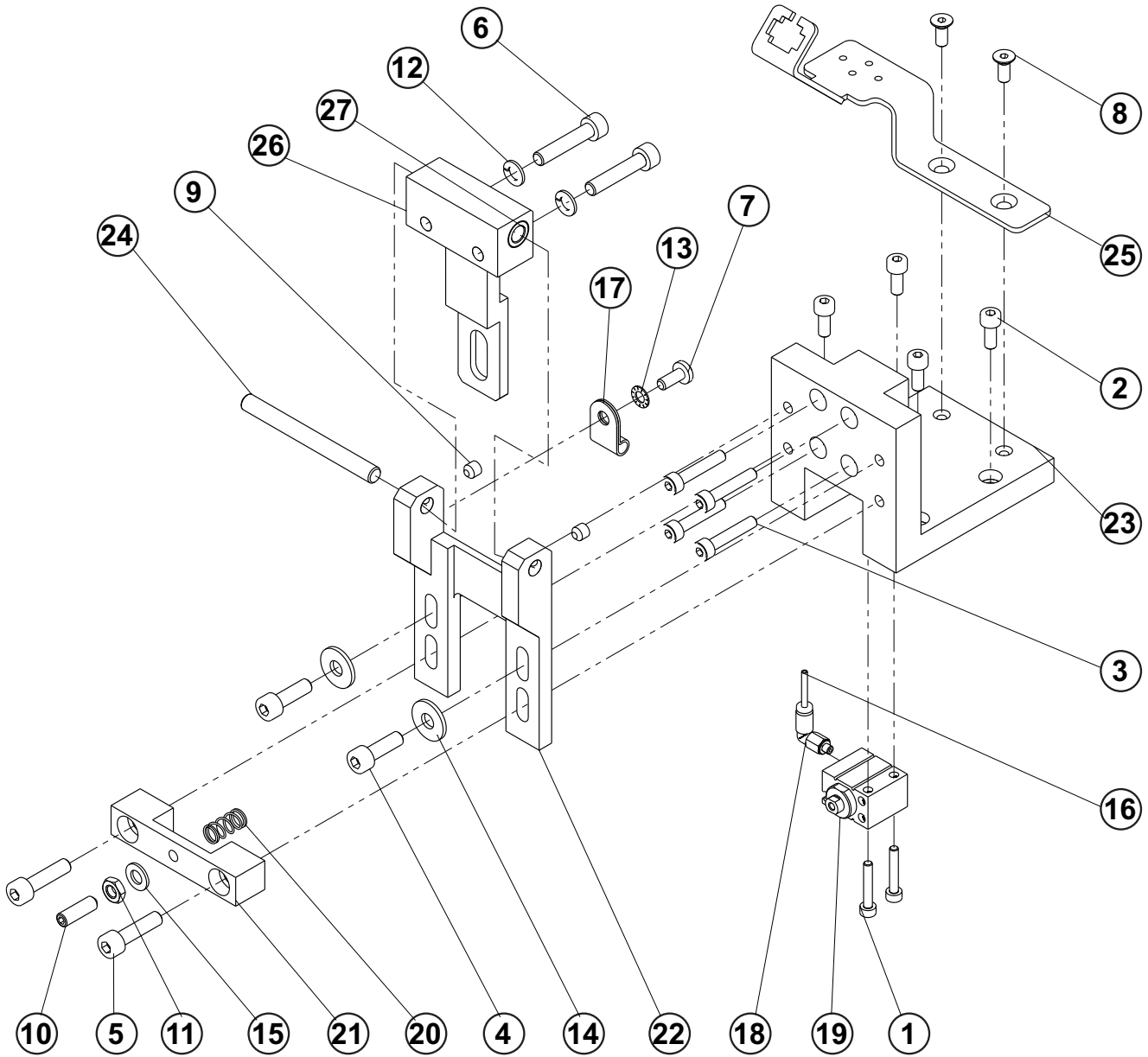



**RIDER**

DET	PART NUMBER	DESCRIPTION	QTY.
01	08.6002.3.018	SCREW M3-18	2
02	08.6002.4.010	SCREW M4-10	4
03	08.6002.4.022	SCREW M4-22	4
04	08.6002.5.016	SCREW M5-16	2
05	08.6002.5.020	SCREW M5-20	2
06	08.6002.5.025	SCREW M5-25	2
07	08.6032.4.010	SCREW M4-10	1
08	08.6102.4.010	SCREW M4-10	2
09	08.6400.5.005	SCREW M5-5	2
10	08.6400.5.016	SCREW M5-16	1
11	08.6712.5.000	NUT M5	1
12	08.6802.5.000	SPRING WASHER M5	2
13	08.6832.4.000	WASHER M4	1
14	08.6842.5.000	WASHER 5	2
15	08.6852.5.000	WASHER 5,3	1
16	12.0008.3.749	AIR TUBING - 8A	1
17	12.0008.4.277	CLAMP	1
18	12.0010.3.072	CONNECTOR	1
19	12.0010.3.182	CYLINDER	1
20	12.3010.0.035	SPRING	1
21	50.0283.0.600	STOP SUPPORT	1
22	50.0285.0.600	HOLDER	1
23	50.0287.0.600	BLOCK	1
24	50.0289.0.300	SHAFT	1
25	50.0291.0.800	HOLDER	1
26	50.0304.0.600	HEAD PIVOT	1
27	50.0311.0.400	BUSHING	2

# LOADER MECHANISM AXIS Y

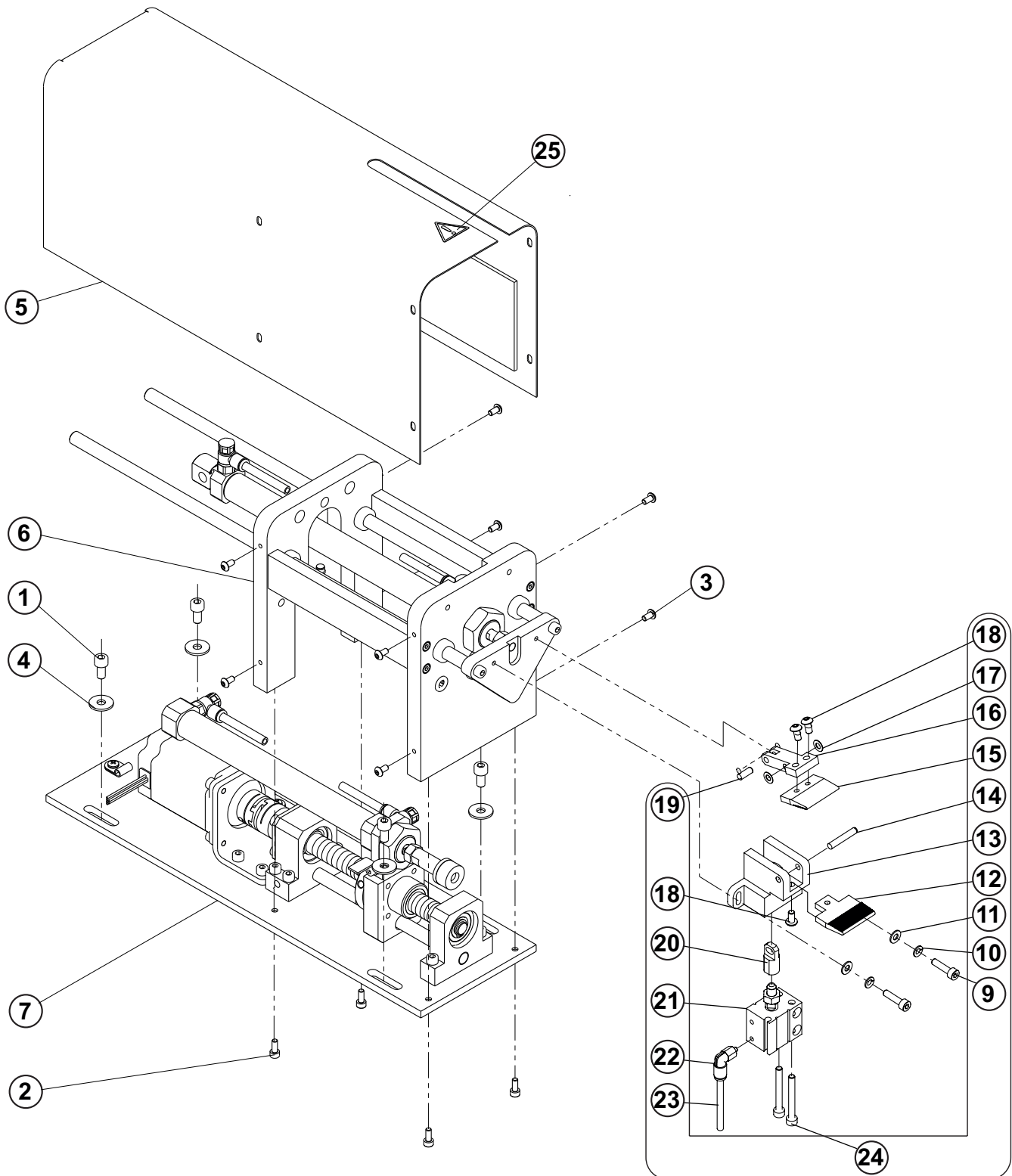

**LOADER MECHANISM AXIS Y**

<b>DET</b>	<b>PART NUMBER</b>	<b>DESCRIPTION</b>	<b>QTY.</b>
01	08.6000.6.012	SCREW M6-12	4
02	08.6002.4.010	SCREW M4-10	4
03	08.6200.4.008	SCREW M4-8	8
04	08.6842.6.000	WASHER M6	4
05	50.0365.0.000	COVER	1
06	50.9064.0.050	FEED - ASSEMBLY	1
07	50.9065.0.050	LENGTH SETTINGS EYELET - ASSEMBLY	1
08	50.9066.0.050	JAWS-ASSEMBLY	1
09	08.6002.4.016	SCREW M4-16	(2)
10	08.6802.4.000	SPRING WASHER M4	(2)
11	08.6852.4.000	WASHER M4	(2)
12	50.0437.0.600	LOWER JAW	(1)
13	50.0363.1.600	BLOCK JAWS	(1)
14	12.1010.2.045	PIN	(1)
15	50.0436.0.600	UPPER JAW	(1)
16	50.0360.1.600	UPPER JAW LEVER	(1)
17	08.6887.4.300	SPACER RING 4x8 h=0,3	(2)
18	08.6202.4.008	SCREW M4-8	(3)
19	12.1010.2.030	PIN	(1)
20	50.0369.0.300	ROD	(1)
21	12.0010.3.191	CYLINDER	(1)
22	12.0010.3.036	CONNECTOR	(1)
23	12.0008.3.416	AIR TUBING	(1)
24	08.6002.4.035	SCREW M4-35	(2)
25	17.0097.5.174	LABEL - WARNING	1

# FEED AXIS Y - ASSEMBLY

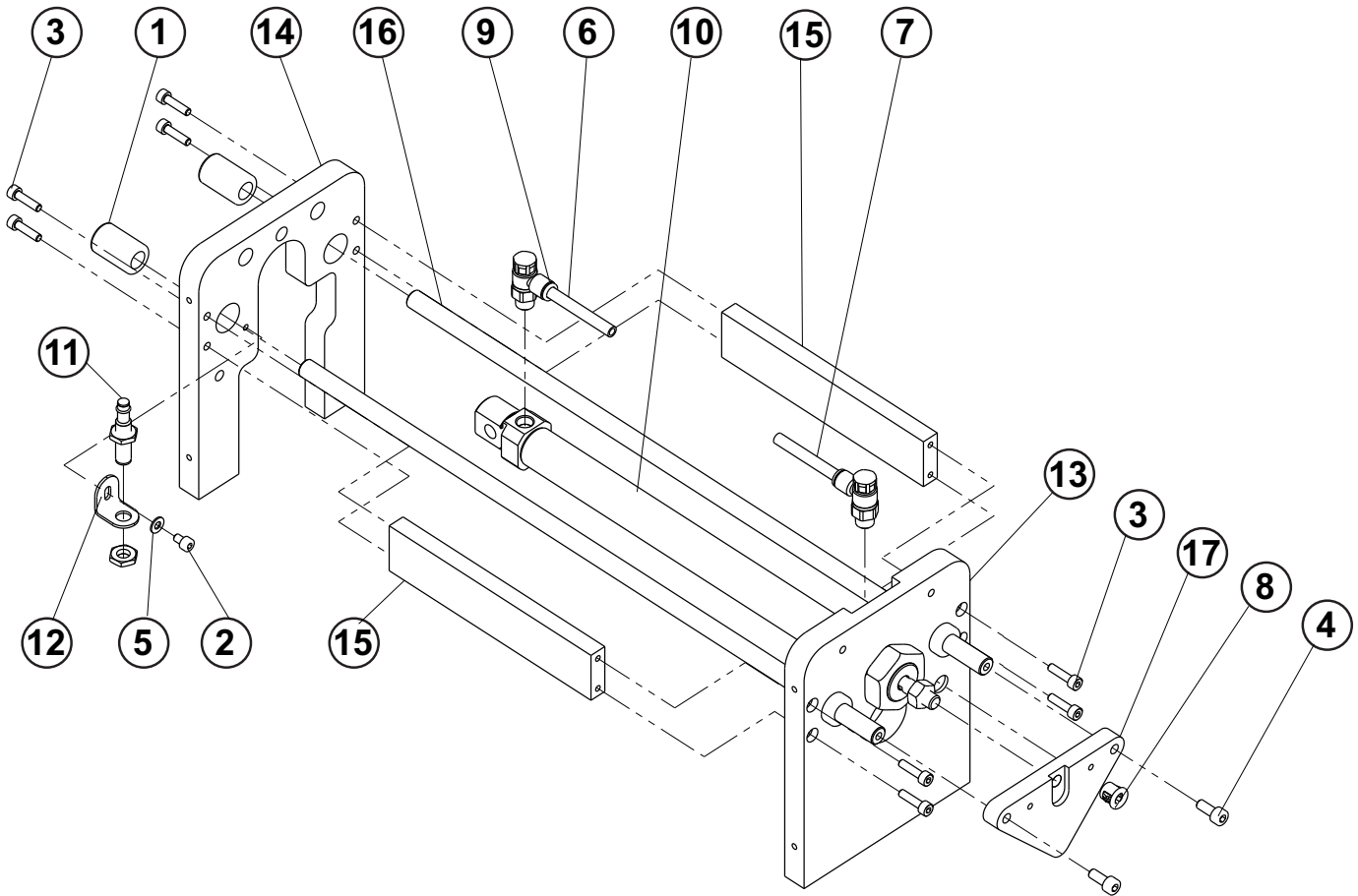



# LENGTH SETTINGS EYELET

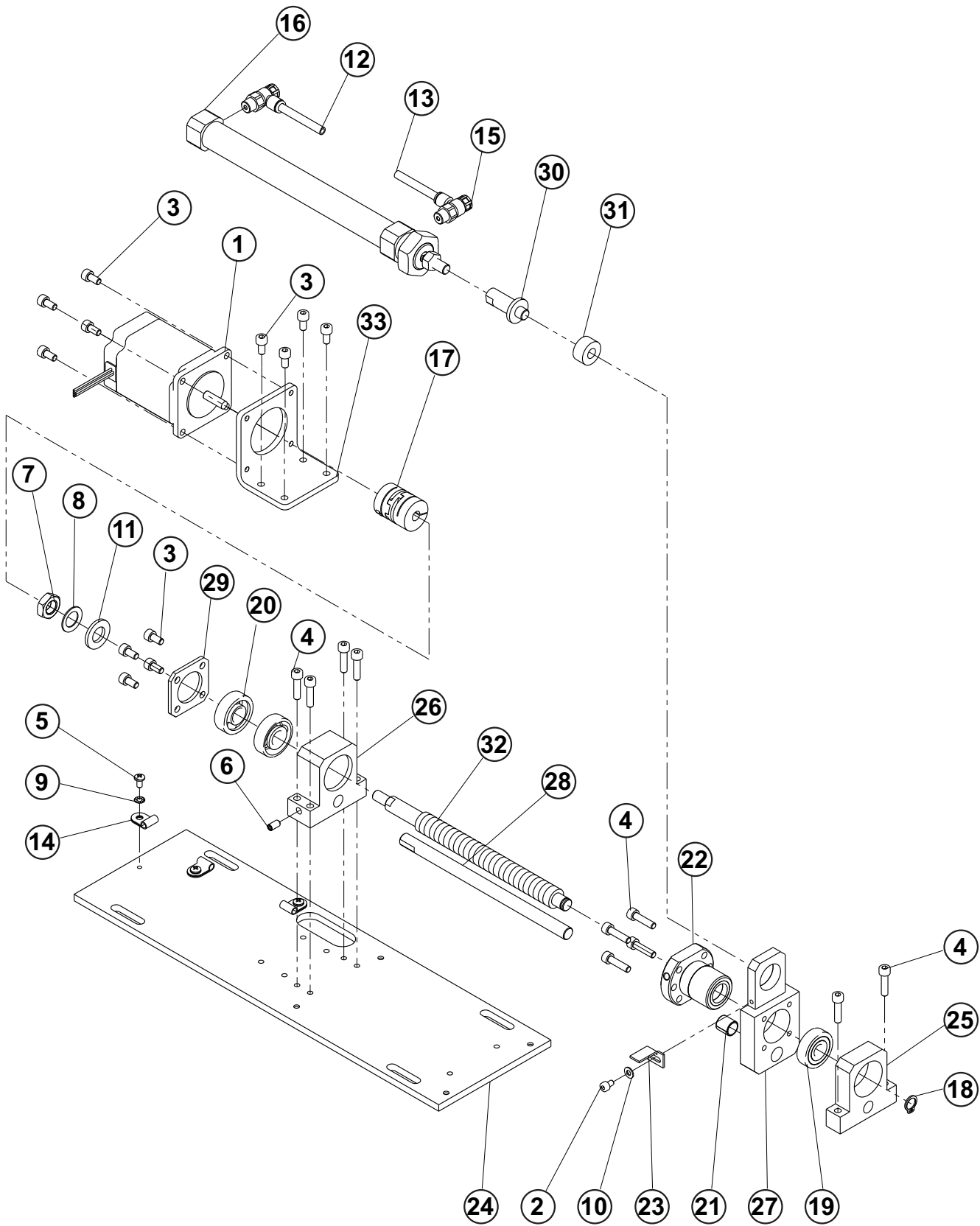

## LENGTH SETTINGS EYELET

DET	PART NUMBER	DESCRIPTION	QTY.
01	06.5000.0.023	STEPPER MOTOR	1
02	08.6002.4.006	SCREW M4-6	1
03	08.6002.5.010	SCREW M5-10	12
04	08.6002.5.020	SCREW M5-20	10
05	08.6032.4.008	SCREW M4-8	3
06	08.6400.5.010	SCREW M5-10	1
07	08.6710.9.500	NUT M12x1,5	1
08	08.6802.9.300	WASHER 12	1
09	08.6832.4.000	WASHER M4	3
10	08.6852.4.000	WASHER M4	1
11	08.6852.9.000	WASHER M12	1
12	12.0008.3.415	AIR TUBING - 3A	1
13	12.0008.3.415	AIR TUBING - 3B	1
14	12.0008.4.277	CLAMP	3
15	12.0010.3.043	SPEED VALVE	2
16	12.0010.3.177	CYLINDER	1
17	50.0345.0.000	COUPLING OLDHAM	1
18	12.1045.1.015	RETAINING RING 10	1
19	12.2010.0.000	BEARING	1
20	12.2010.0.023	BEARING	2
21	12.2080.0.016	BUSHING	1
22	12.2099.3.007	BALL NUT	1
23	50.0026.0.800	SENSOR PLATE	1
24	50.0335.0.800	PLATE	1
25	50.0336.0.600	BEARING HOUSING - FIXED	1
26	50.0337.0.600	BEARING HOUSING - FIXED	1
27	50.0338.0.600	BEARING HOUSING - SLIDING	1
28	50.0339.0.300	ROD	1
29	50.0340.0.800	BEARING COVER	1
30	50.0341.0.300	STUD	1
31	50.0342.0.990	SILENCER	1
32	50.0343.0.300	BALLSCREW 16	1
33	50.0344.0.800	MOTOR HOLDER	1

# EQUIPMENT BASE PLATE

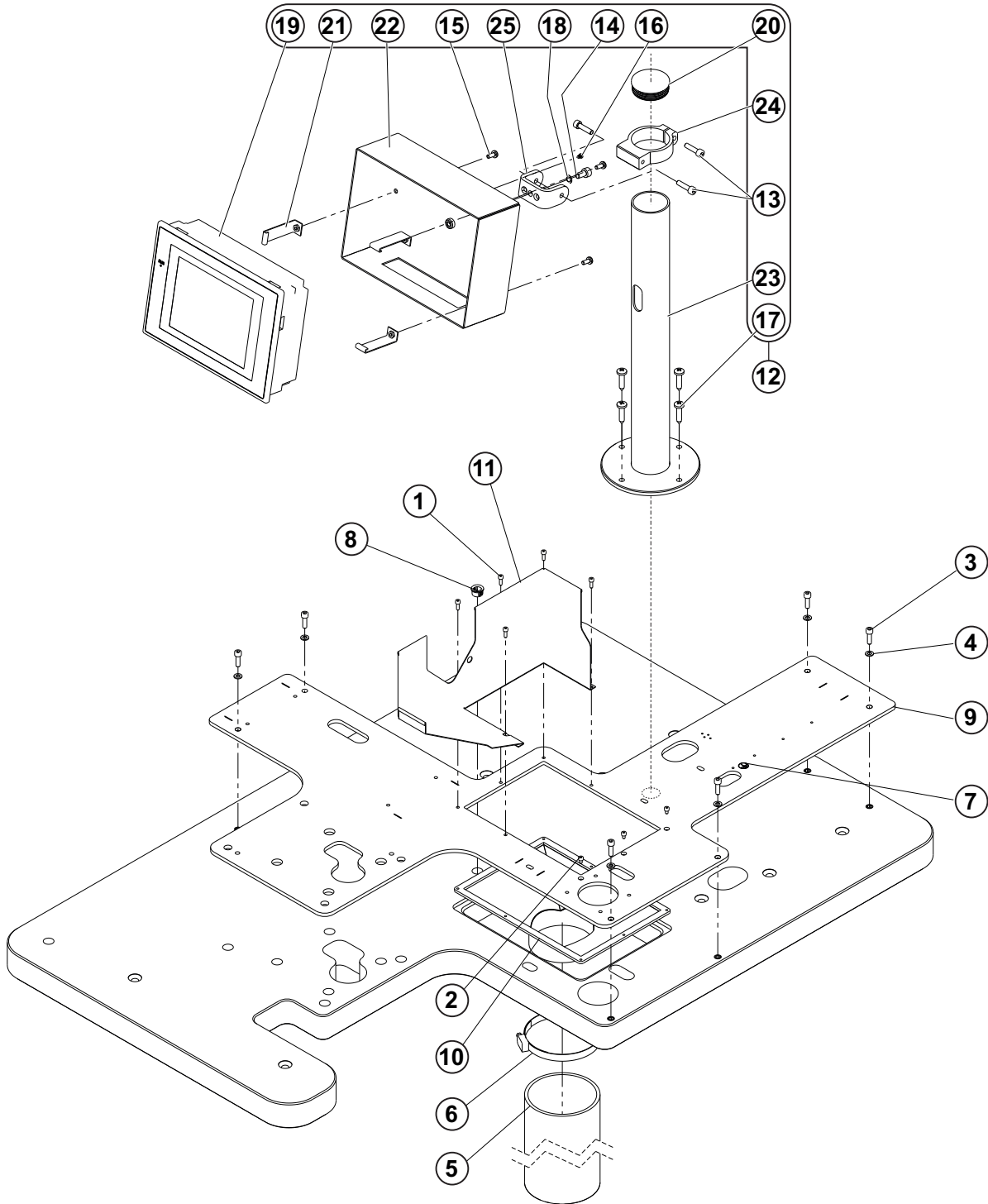



## EQUIPMENT BASE PLATE

DET	PART NUMBER	DESCRIPTION	QTY.
01	08.6002.4.012	SCREW M4-12	5
02	08.6002.4.006	SCREW M4-6	3
03	08.6002.6.020	SCREW M6-20	6
04	08.6852.6.000	WASHER 6,4	6
05	12.0008.3.275	TUBE VENTITEC	1
06	12.0008.3.276	CLAMP TUBE	1
07	12.0008.4.052	LABEL GROUND	1
08	12.0008.4.222	BUSHING SNAP	1
09	50.0329.1.800	EQUIPMENT BASE PLATE	1
10	50.0370.1.000	DRAIN CLIPPINGS	1
11	50.0371.0.000	HEM	1
12	50.9031.0.050	LCD DISPLAY - ASSEMBLY	1
13	08.6002.5.020	SCREW M5-20	(3)
14	08.6002.6.012	SCREW M6-12	(1)
15	08.6032.4.010	SCREW M4-10	(3)
16	08.6662.3.006	SCREW	(1)
17	08.6663.5.025	SCREW 4,8-25	(4)
18	08.6802.6.000	SPRING WASHER M6	(1)
19	06.8050.0.002	DISPLAY ATLAS PROGRAMMED	(1)
20	12.0010.6.924	PLUG 42,4	(1)
21	24.0168.0.000	DISPLAY HOLDER - OMRON	(3)
22	24.0169.0.000	PANEL COVER - OMRON	(1)
23	50.0380.0.000	HOLDER	(1)
24	50.0385.0.600	CLAMP	(1)
25	68.0357.0.800	BRACKET	(1)

# KIT ATLAS SINGLE - HANDED SWITCH

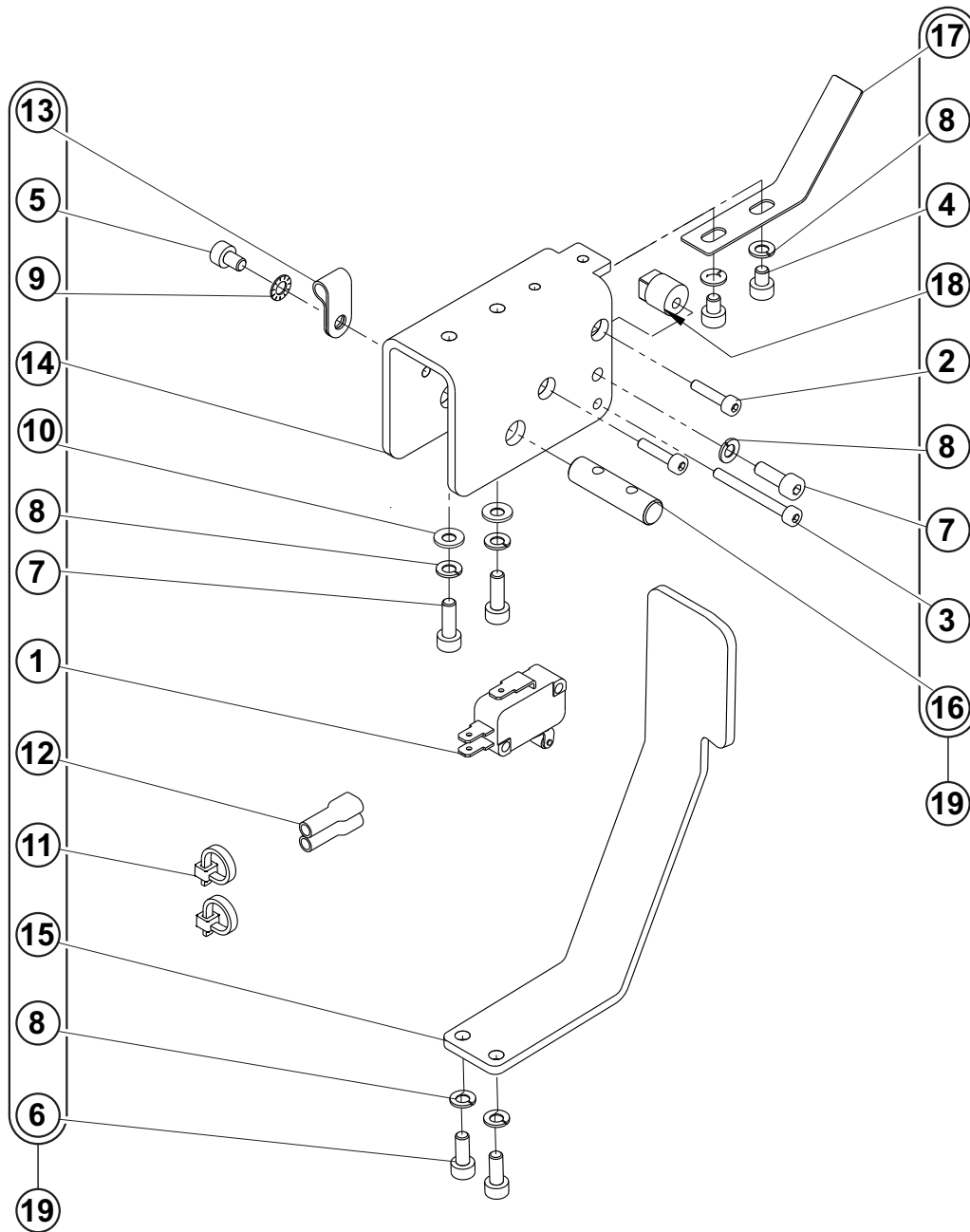

**KIT ATLAS SINGLE - HANDED SWITCH**

DET	PART NUMBER	DESCRIPTION	QTY.
01	06.0120.0.000	SWITCH-MICRO	(1)
02	08.6002.3.014	SCREW M3-14	(2)
03	08.6002.3.030	SCREW M3-30	(1)
04	08.6002.4.005	SCREW M4-5	(2)
05	08.6002.4.006	SCREW M4-6	(1)
06	08.6002.4.010	SCREW M4-10	(2)
07	08.6002.4.012	SCREW M4-12	(3)
08	08.6802.4.000	SPRING WASHER M4	(7)
09	08.6832.4.000	WASHER M4	(1)
10	08.6852.4.000	WASHER M4	(2)
11	12.0008.4.290	CABLE TIE 2x100	(2)
12	12.0008.4.624	CRIMP RECEPTACLES 4.8x0.5	(2)
13	12.0008.4.913	CLAMP CABLE UCF-0,5	(1)
14	50.0427.0.800	HOLDER	(1)
15	50.0428.0.800	LEVER	(1)
16	50.0429.0.300	SHAFT	(1)
17	50.0430.0.800	SPRING	(1)
18	50.0431.0.300	ECCENTR	(1)
19	03.5550.0.004	KIT ATLAS SINGLE - HANDED SWITCH	1

# BELT-LOOP ALIGNMENT

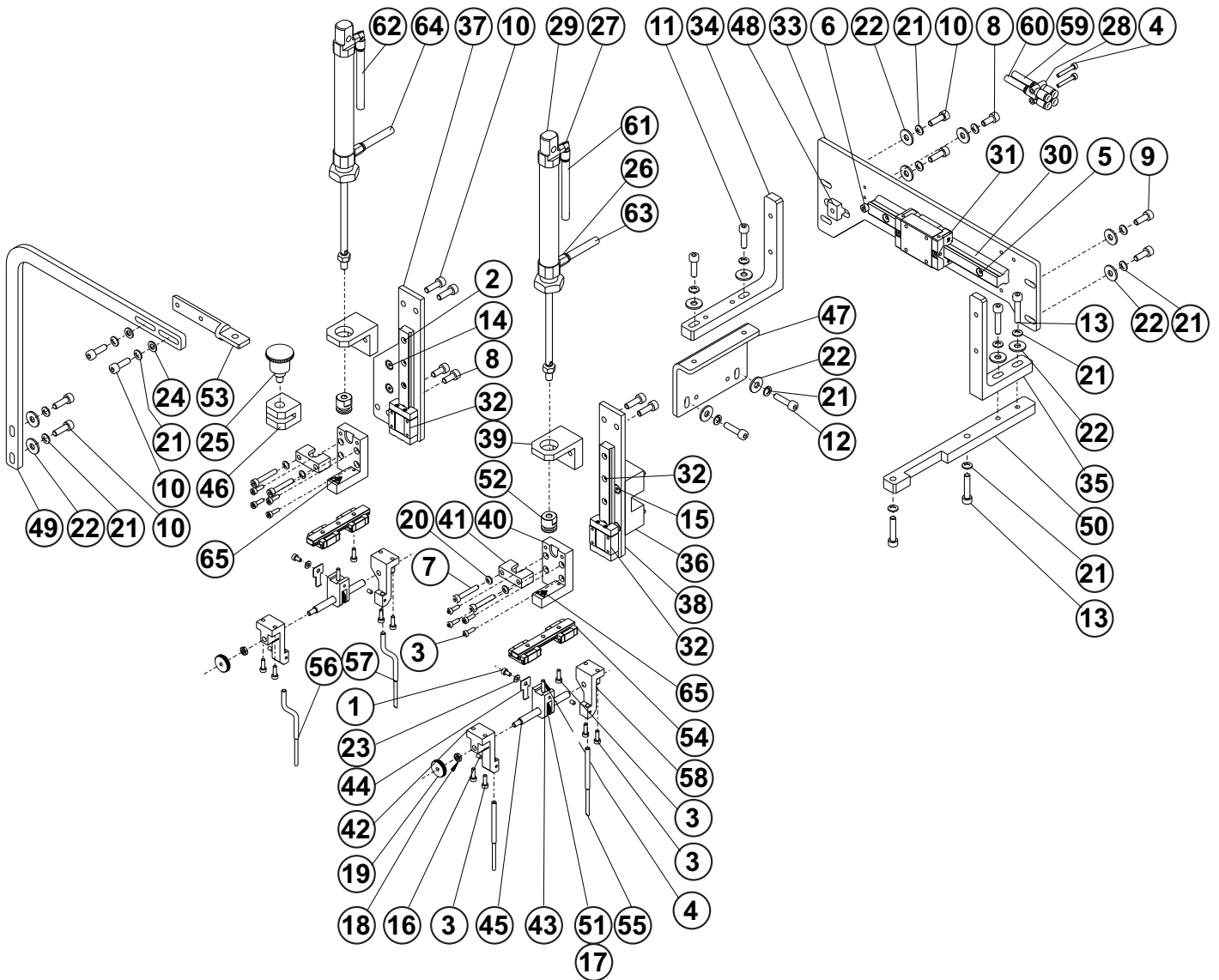

## BELT-LOOP ALIGNMENT

DET	PART NUMBER	DESCRIPTION	QTY.
01	08.6002.3.006	SCREW M3-6	2
02	08.6002.3.008	SCREW M3-8	9
03	08.6002.3.010	SCREW M3-10	18
04	08.6002.3.020	SCREW M3-20	4
05	08.6002.4.016	SCREW M4-16	3
06	08.6002.4.020	SCREW M4-20	1
07	08.6002.4.025	SCREW M4-25	4
08	08.6002.5.012	SCREW M5-12	3
09	08.6002.5.014	SCREW M5-14	2
10	08.6002.5.016	SCREW M5-16	10
11	08.6002.5.018	SCREW M5-18	2
12	08.6002.5.020	SCREW M5-20	2
13	08.6002.5.025	SCREW M5-25	4
14	08.6102.4.010	SCREW M4-10	4
15	08.6102.4.035	SCREW M4-35	4
16	08.6400.3.006	SCREW M3-6	4
17	08.6400.4.004	SCREW M4-4	2
18	08.6712.4.000	NUT M4	2
19	08.6772.4.000	NUT M4	2
20	08.6802.4.000	SPRING WASHER M4	4
21	08.6802.5.000	SPRING WASHER M5	21
22	08.6842.5.000	WASHER 5	13
23	08.6852.3.000	WASHER M3	2
24	08.6852.5.000	WASHER 5,3	2
25	12.0008.6.232	PLUNGERS M10x1	1
26	12.0010.3.027	CONNECTOR	2
27	12.0010.3.028	CONNECTOR	2
28	12.0010.3.037	CONNECTOR	2
29	12.0010.3.078	CYLINDER	2
30	12.2070.1.039	LINEAR RAIL	1
31	12.2070.1.044	GUIDE	1
32	12.2070.1.064	GUIDE	2
33	50.0390.0.800	PLATE	1
34	50.0391.0.000	CONSOLE	1
35	50.0392.0.000	CONSOLE	1
36	50.0393.0.600	BRACKET	1
37	50.0394.0.800	BRACKET	1
38	50.0395.0.800	BRACKET	1
39	50.0396.0.600	HOLDER	2
40	50.0397.0.600	BASE OF UNIT	2
41	50.0398.0.600	HOLDER	2
42	50.0399.0.600	FINGER - RIGHT	2
43	50.0401.0.600	FORK	2
44	50.0402.0.800	SPRING	2
45	50.0403.0.300	SCREW	2
46	50.0404.0.600	BLOCK	1

# BELT-LOOP ALIGNMENT

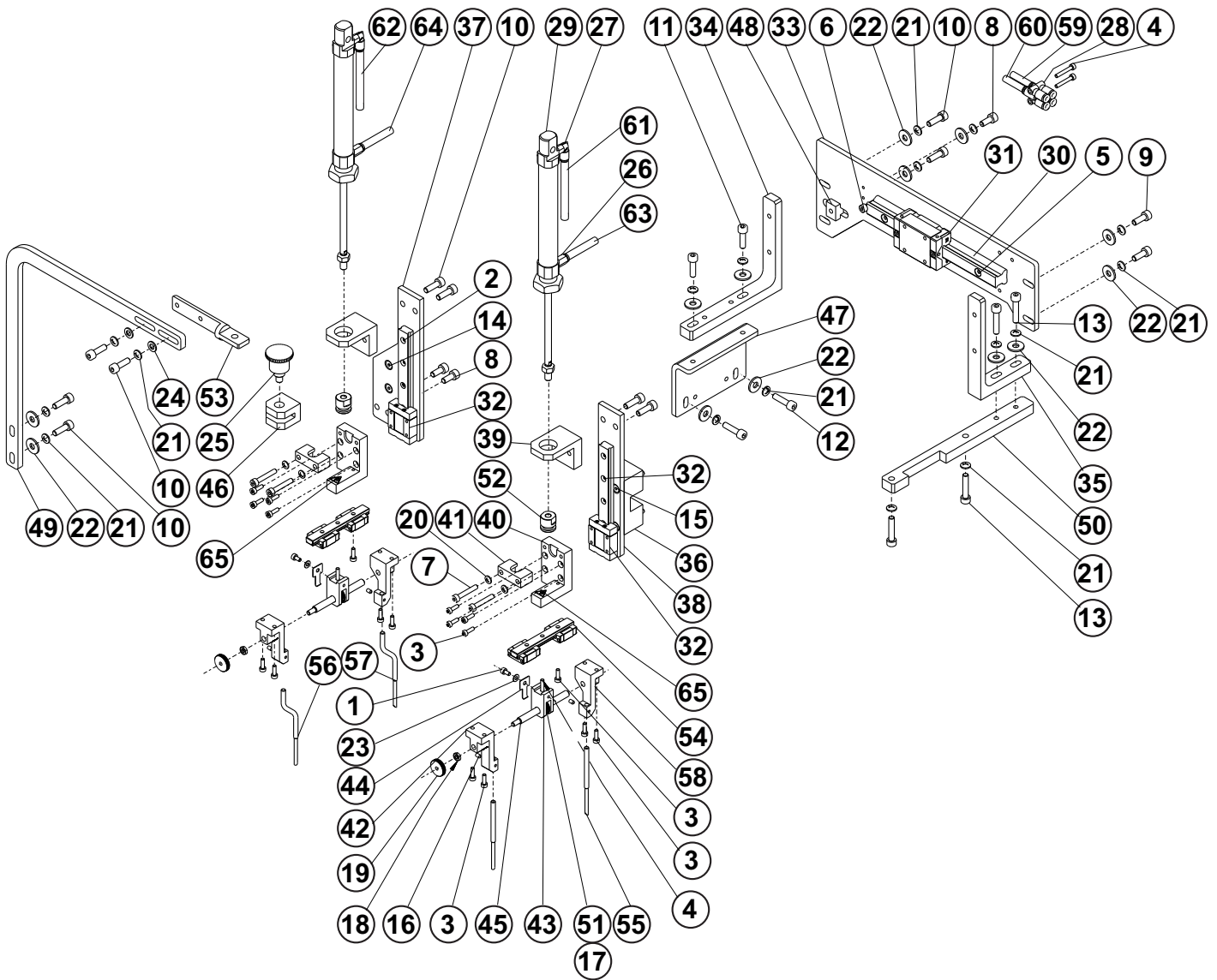

## BELT-LOOP ALIGNMENT

DET	PART NUMBER	DESCRIPTION	QTY.
47	50.0405.0.800	HOLDER	1
48	50.0406.0.600	STOP	1
49	50.0407.0.800	ARM	1
50	50.0408.0.600	HOLDER	1
51	50.0409.0.400	RING	2
52	50.0410.0.300	NUT	2
53	50.0411.0.600	SPUR	1
54	50.0415.0.000	GUIDE	2
55	50.9914.0.201	FORK 3	2
56	50.9915.0.201	FORK 3 - LEFT	1
57	50.9916.0.201	FORK 3 - RIGHT	1
58	50.0400.0.600	FINGER - LEFT	2
59	12.0008.3.416	AIR TUBE 21A	1
60	12.0008.3.416	AIR TUBE 21B	1
61	12.0008.3.416	AIR TUBE 21A1	1
62	12.0008.3.416	AIR TUBE 21A2	1
63	12.0008.3.416	AIR TUBE 21B1	1
64	12.0008.3.416	AIR TUBE 21B2	1
65	12.8000.0.437	LABEL-DANGER INJURY	2

# TABLE ASSEMBLY

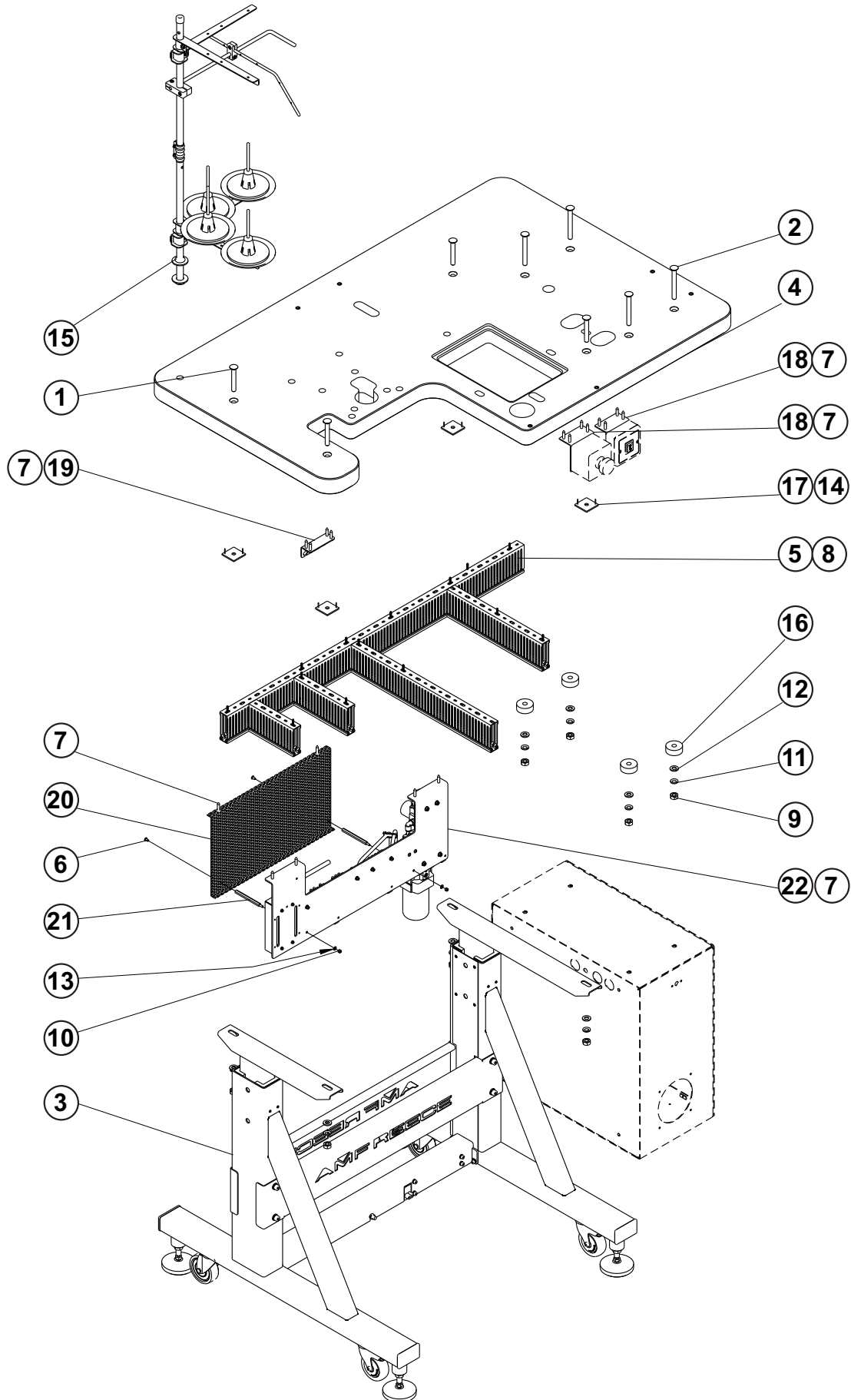
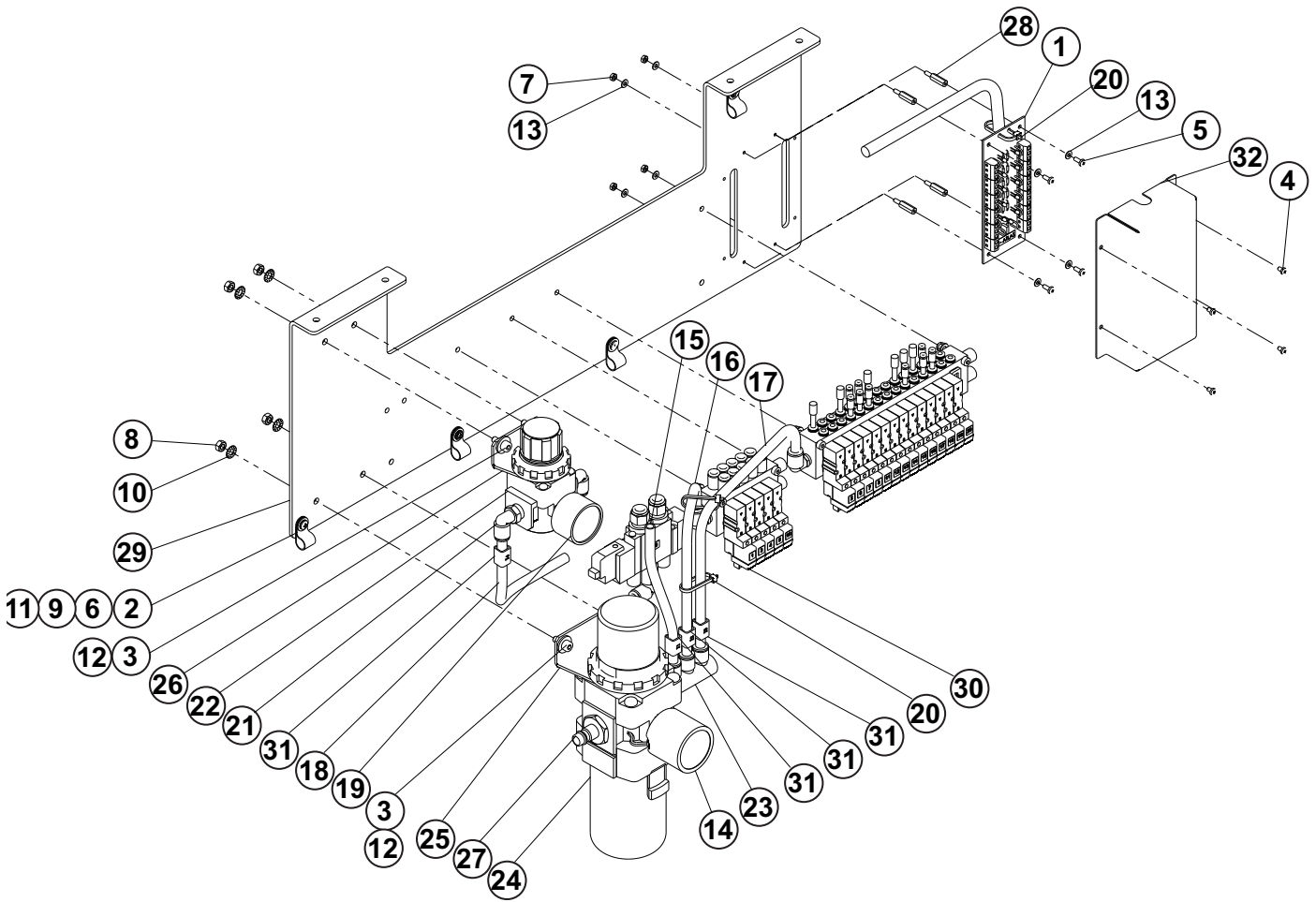



**TABLE ASSEMBLY**

DET	PART NUMBER	DESCRIPTION	QTY.
01	04.9015.0.362	SCREW M10-70	4
02	04.9015.0.363	SCREW M10-90	4
03	04.9050.0.050	FRAME KIT	1
04	04.9050.0.900	TABLE TOP ATLAS	1
05	06.5000.0.007	LATCH FOR CABLE TABLE	1
06	08.6032.4.008	SCREW M4-8	2
07	08.6663.5.025	SCREW 4,8-25	18
08	08.6676.3.020	SCREW ST3,5-20	14
09	08.6702.0.000	NUT M10	8
10	08.6732.4.000	NUT M4	2
11	08.6802.0.000	SPRING WASHER M10	8
12	08.6852.0.000	WASHER 10,5	8
13	08.6852.4.000	WASHER M4	2
14	12.4010.0.004	NAIL 1,6x20	8
15	12.9900.9.000	THREAD STAND ASSY. 4-THREAD	1
16	15.6005.0.990	SHOCK MOUNT	4
17	17.0094.0.200	WASHER	4
18	50.0146.0.800	HOLDER	2
19	50.0374.0.800	HOLDER	1
20	50.0416.0.800	COVER	1
21	50.0417.0.100	DISTANCE NUT M4-80	2
22	50.7001.0.050	FILTER REGULATOR - ASSEMBLY	1

# FILTER REGULATOR





# VALVE BLOCK

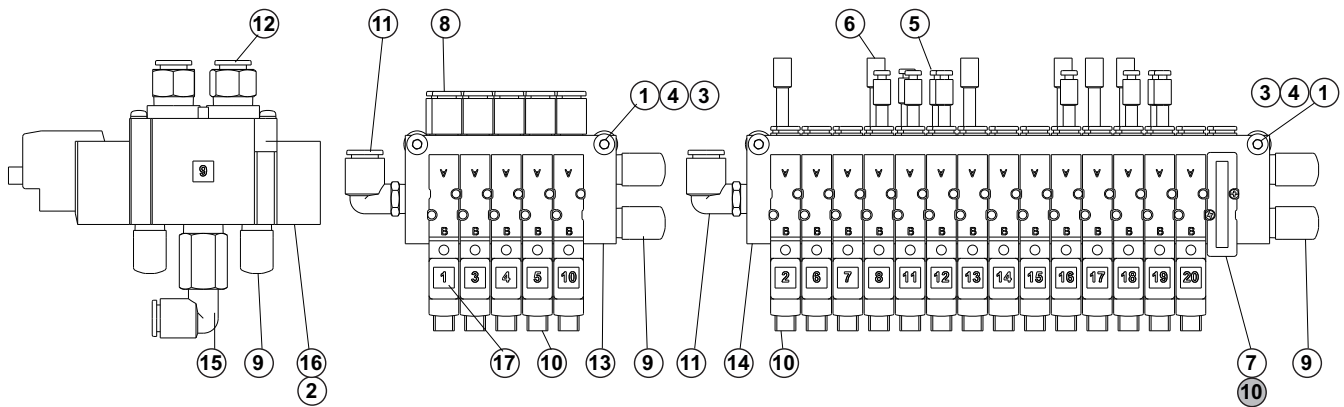

**10** FOR BELT-LOOP ALIGNMENT ASSEMBLY

## VALVE BLOCK

DET	PART NUMBER	DESCRIPTION	QTY.
01	08.6002.4.030	SCREW M4-30	4
02	08.6032.4.008	SCREW M4-8	2
03	08.6732.4.000	NUT M4	4
04	08.6852.4.000	WASHER M4	4
05	12.0008.3.170	REDUCTION	9
06	12.0008.3.426	PLUG	6
07	12.0008.3.790	BLANKING PLATE	1
08	12.0010.3.098	CONNECTOR	10
09	12.0010.3.099	SILENCER	6
10	12.0010.3.105	5/2 VALVE	19
11	12.0010.3.106	CONNECTOR	2
12	12.0010.3.116	CONNECTOR	2
13	12.0010.3.198	MANIFOLD PLATE	1
14	12.0010.3.199	MANIFOLD PLATE	1
15	12.0010.3.212	CONNECTOR	1
16	12.0010.3.213	5/2 VALVE	1
17	12.8000.0.446	LABELS - VALVES 1-30	1

# ELECTROBOX

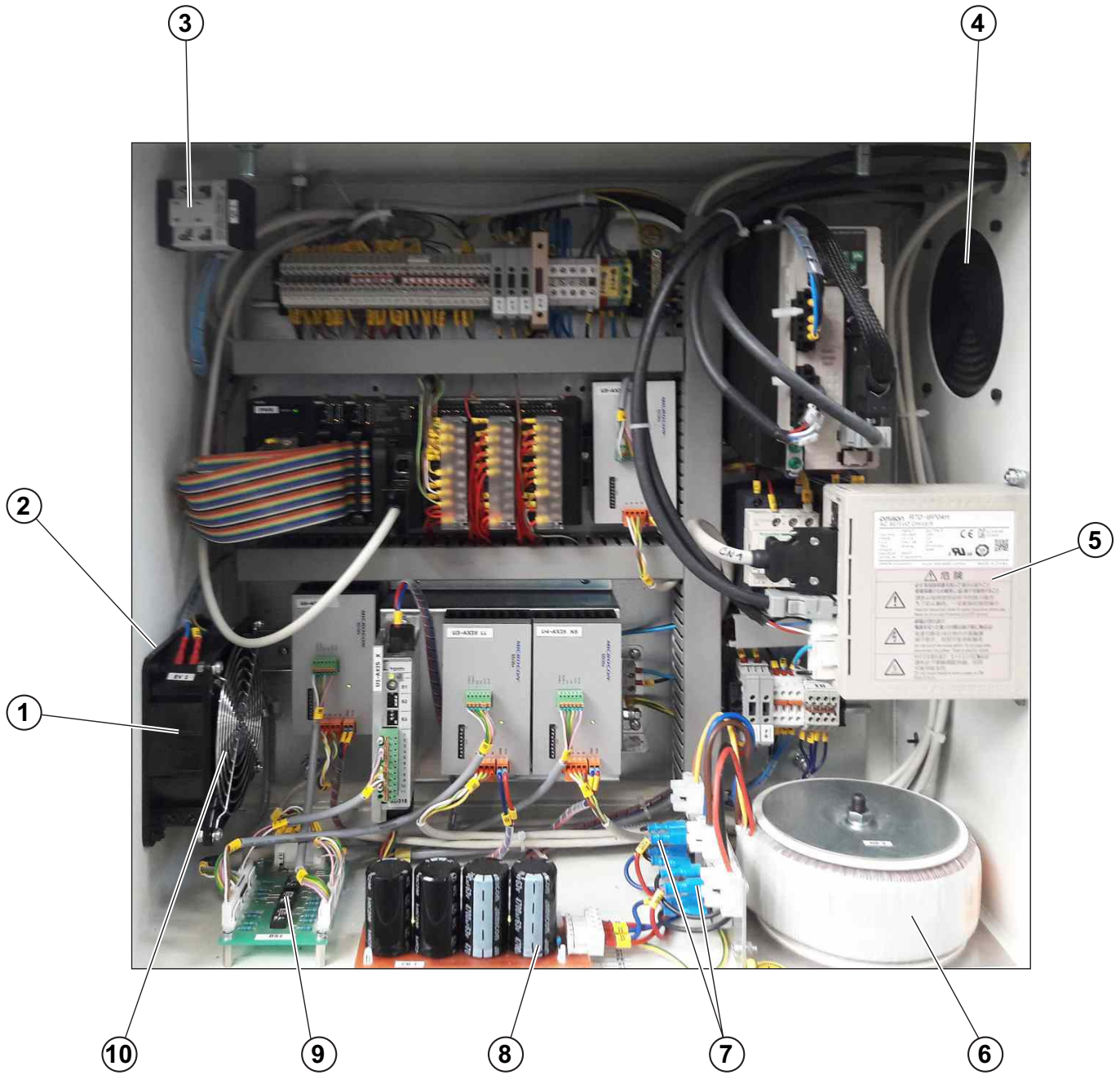



# ELECTROBOX

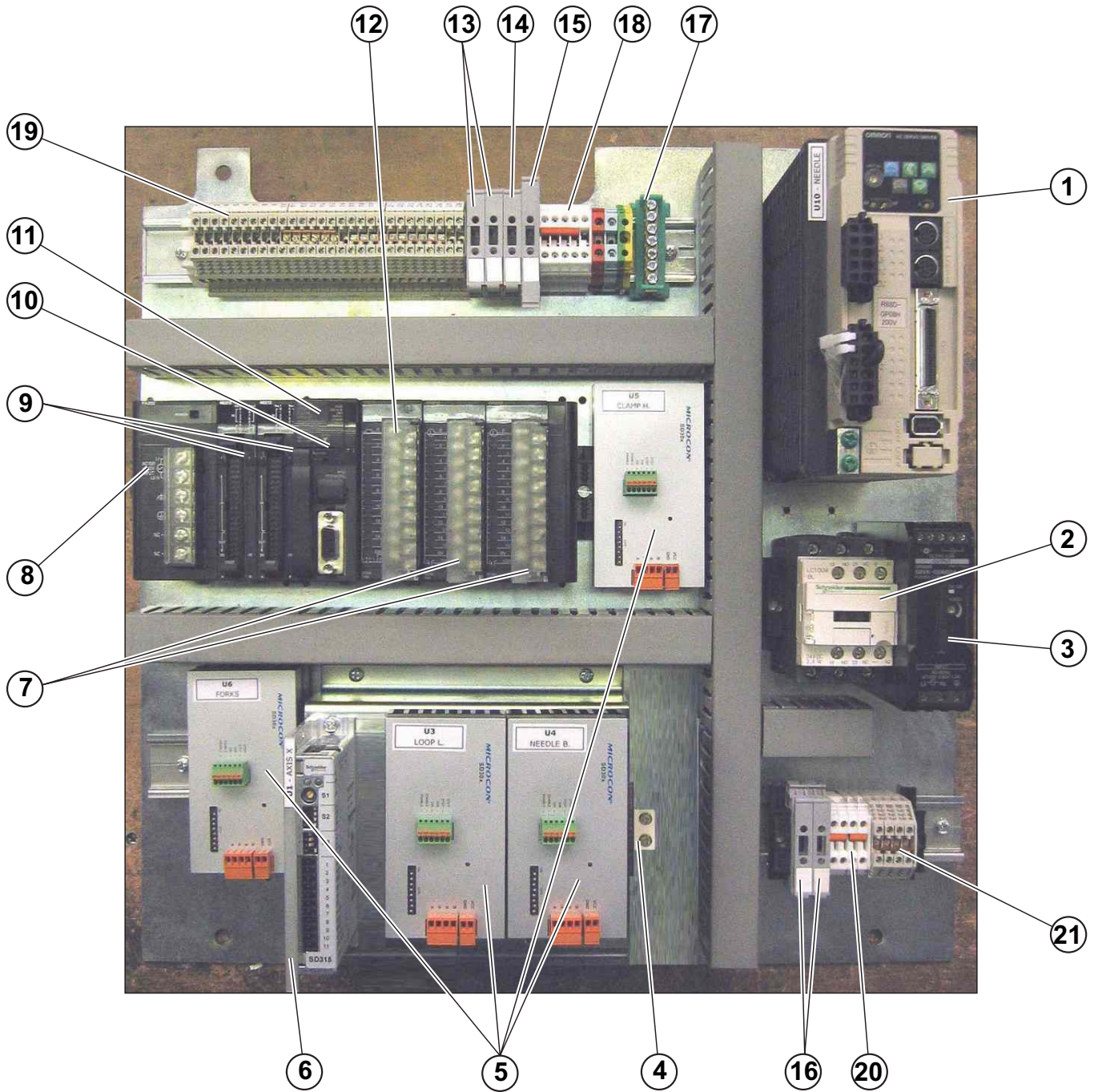



**ELECTROBOX**

DET	PART NUMBER	DESCRIPTION	QTY.
01	06.8050.0.003	SERVODRIVE U10	1
02	12.0008.4.833	CONTACTOR KM1	1
03	12.0010.4.168	POWER GS1	1
04	12.0008.4.751	FILTER	1
05	12.0008.4.898	DRIVER	4
06	12.0010.4.161	DRIVER	1
07	12.0010.4.284	OUTPUT BLOCK	2
08	12.0010.4.281	POWER	1
09	12.0010.4.282	IN/OUT BLOCK	2
10	06.8050.0.001	PLC ATLAS	1
11	12.0010.4.163	PLC BATTERY	1
12	12.0010.4.283	INPUT BLOCK	1
13	12.0008.4.109	F1, F2 FUSE T5A	2
14	12.0008.4.664	F3 FUSE T10A	1
15	12.0010.4.259	F4 FUSE T16A	1
16	12.0008.4.664	F5, F6 FUSE T10A	2
17	12.0008.4.050	TERMINAL PE	1
18		TERMINAL X0	
19		TERMINAL X1	
20		TERMINAL X2	
21		TERMINAL X51	

# ACCESSORIES



## ACCESSORIES

DET	PART NUMBER	DESCRIPTION	QTY.
01	02.0128.1.113	NEEDLE	10
02	02.1340.1.112	NEEDLE	10
03	05.1322.0.000	OIL CAN	1
04	12.0008.6.001	SCREWDRIVER RECA	1
05	12.0008.6.003	SCREWDRIVER	1
06	12.0008.6.005	SCREWDRIVER	1
07	12.0008.6.108	FORK SPANNER	1
08	12.0008.6.109	FORK SPANNER	1
09	12.0008.6.111	FORK SPANNER	1
10	12.0008.6.200	NEEDLE THREADER	1
11	12.0008.6.215	TWEEZERS	1
12	49910018	I.N. 020-260-051 PRACOVNÍ HÁČEK	1
13	84.0003.0.390	84-19 METRIC ALLEN	1

# ACCESSORIES

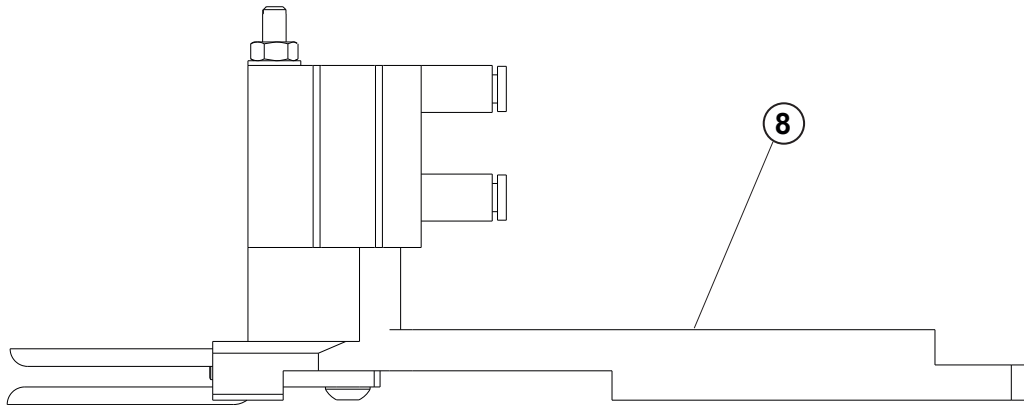
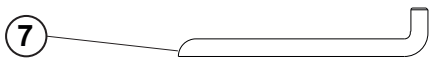
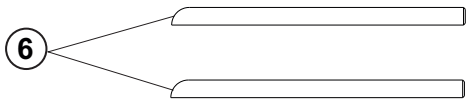
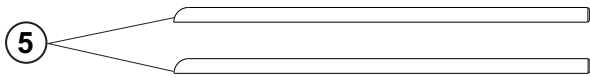
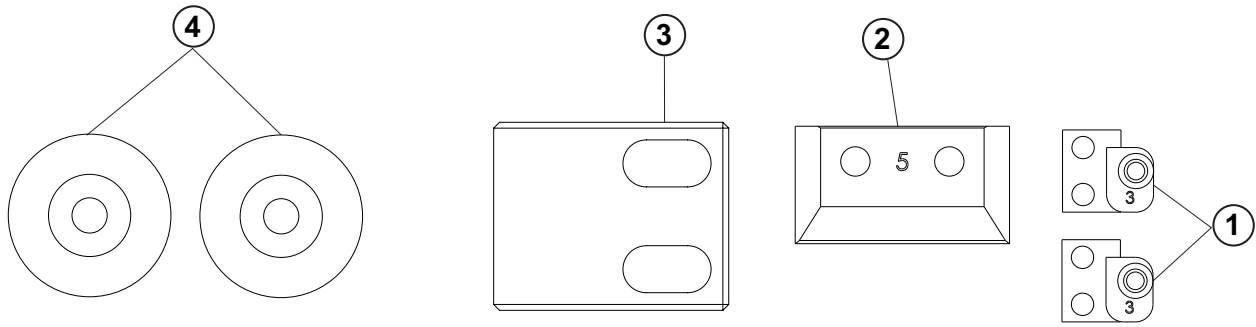

**ACCESSORIES**

<b>DET</b>	<b>PART NUMBER</b>	<b>DESCRIPTION</b>	<b>QTY.</b>
01	50.9901.0.602	THROAT PLATE	2
02	50.9906.0.601	KNIFE 5	1
03	50.9905.1.601	CUTTING STEEL	1
04	27378629	BOBBIN	2
05	50.9907.0.204	FORK 2,5-70	2
06	50.9911.0.201	FORK 3	2
07	50.9908.0.201	FORK 3 - CENTRAL	1
08	50.9081.0.050	CENTRAL	1

# ACCESSORIES

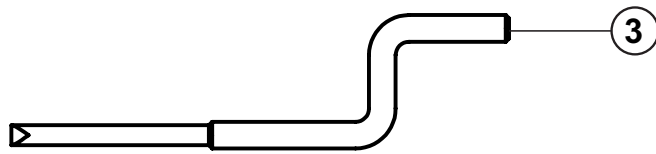
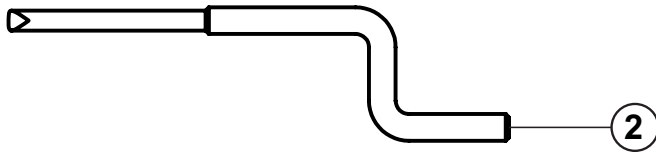
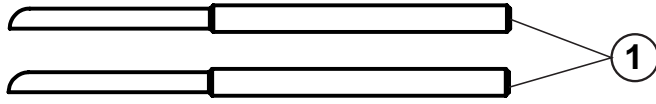

---



**ACCESSORIES**

DET	PART NUMBER	DESCRIPTION	QTY.
01	50.9914.0.201	FORK 3	2
02	50.9915.0.201	FORK 3 - LEFT	1
03	50.9916.0.201	FORK 3 - RIGHT	1

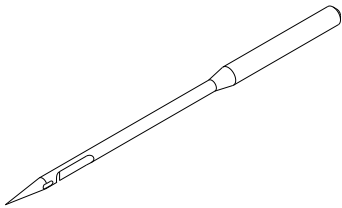
## ACCESSORIES

			
	<b>NEEDLE</b>		<b>SIZE</b>
✓	02.1340.1.112	NEEDLE 134 - 110 Nm GEBEDUR	
•	02.0128.1.113	NEEDLE UY128 SAN 6 - 120 Nm GEBEDUR	

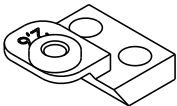
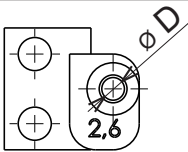
			
	<b>THROAT PLATE</b>		<b>SIZE "D"</b>
✓	50.9901.0.601	Ø 2,6	
•	50.9901.0.602	Ø 3	

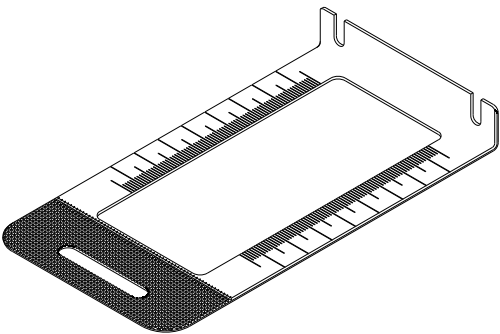
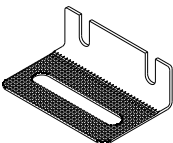
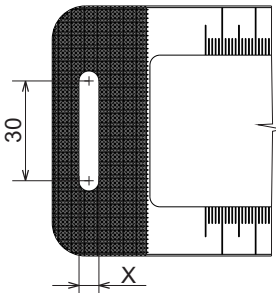
					
	<b>BEDPLATE FIXED</b>	<b>BEDPLATE SLIDING</b>		<b>SIZE "X"</b>	
✓	50.9903.0.801	50.9904.0.801		6	
○	50.9903.0.802	50.9904.0.802		8	
○	50.9903.0.803	50.9904.0.803		4,5	

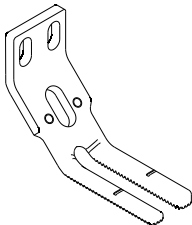
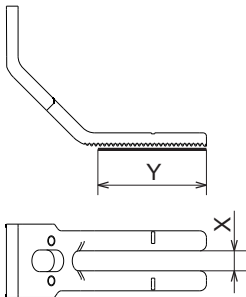
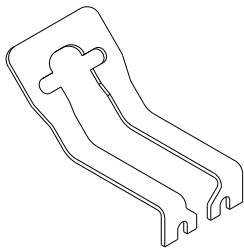
					
	<b>CLAMP FOOT</b>	<b>SIZE "X"</b>	<b>SIZE "Y"</b>	<b>FLEXIBLE STOP</b>	
✓	50.9902.0.804	6	15	50.9920.0.801	
○	50.9902.0.801	6	15		
○	50.9902.0.802	6	30		
○	50.9902.0.803	4,5	15		

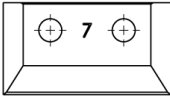
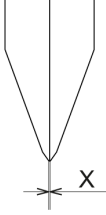

**ACCESSORIES**

		
	<b>CUTTING STEEL</b>	<b>SIZE "X"</b>
•	50.9906.0.601	0,05
✓	50.9906.0.602	0,07

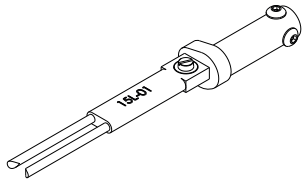
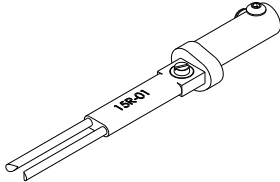
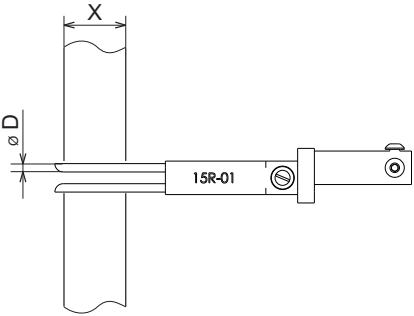
					
	<b>FORK LEFT</b>	<b>FORK RIGHT</b>	<b>SIZE "D"</b>	<b>SIZE "X"</b>	
✓	50.9085.0.050	50.9086.0.050	ø 2,5	15	

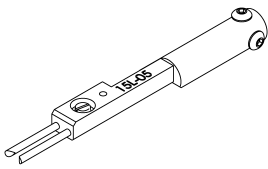
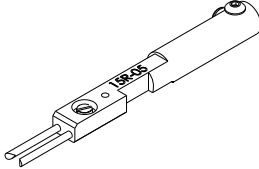
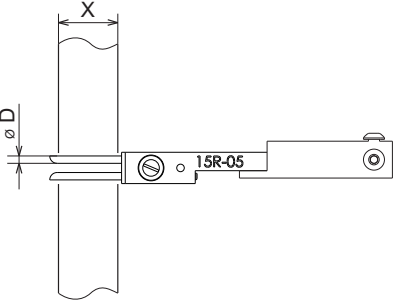
					
	<b>FORK LEFT</b>	<b>FORK RIGHT</b>	<b>SIZE "D"</b>	<b>SIZE "X"</b>	
○	50.9077.0.050	50.9078.0.050	ø 2,5	15	
○	50.9079.0.050	50.9080.0.050	ø 2,5	30	
○	50.9083.0.050	50.9084.0.050	ø 2	15	

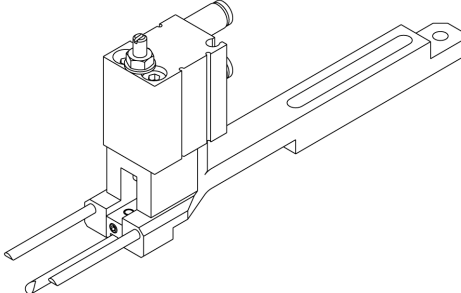
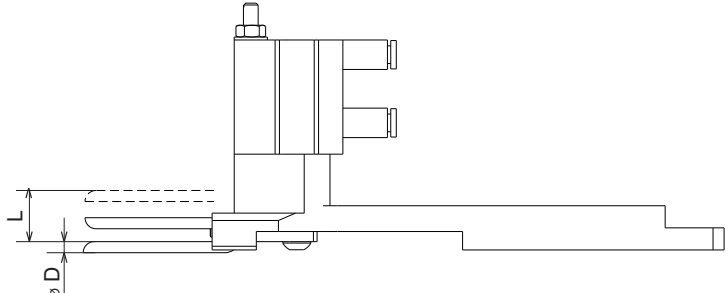
			
	<b>CENTRAL ARM</b>	<b>SIZE "D"</b>	<b>SIZE "L"</b>
•	50.9081.0.050	ø 3	15
✓	50.9082.0.050	ø 3	5

# ACCESSORIES

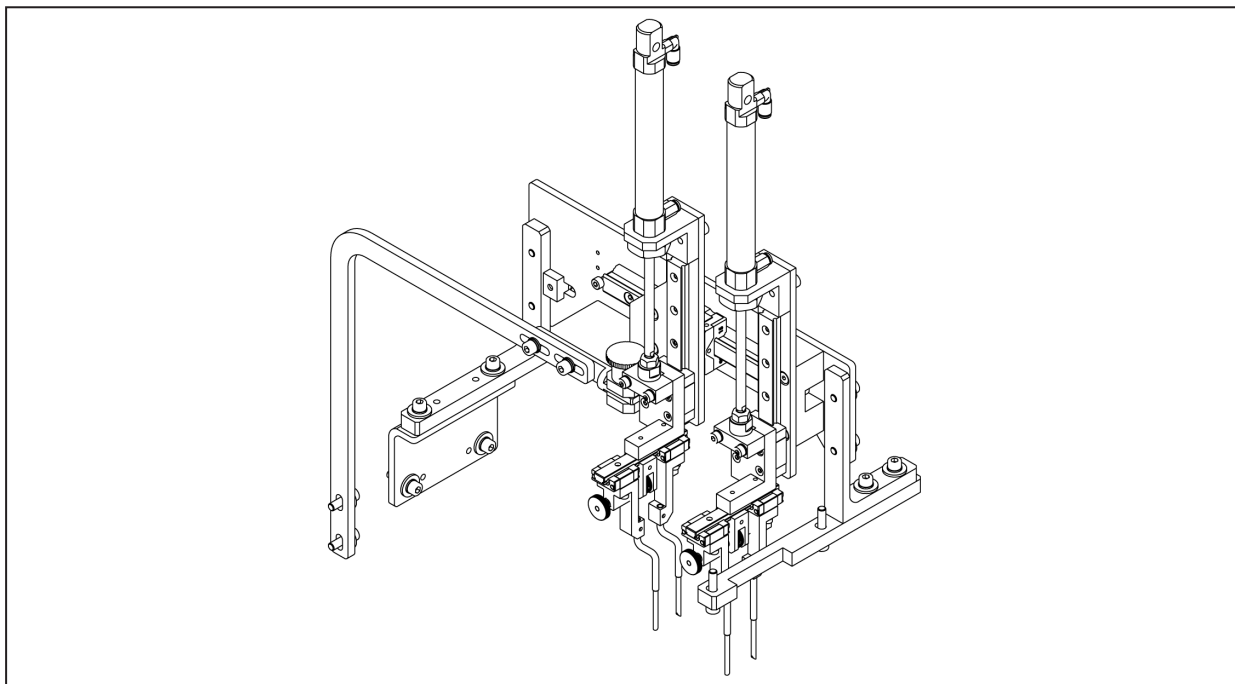

	<b>BELT-LOOP ALIGNMENT ASSEMBLY</b>	
○	03.5550.0.003	

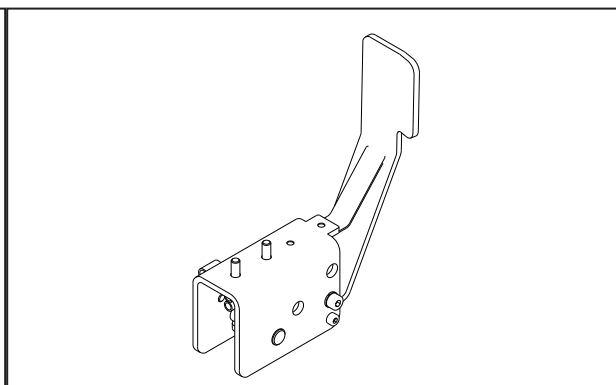
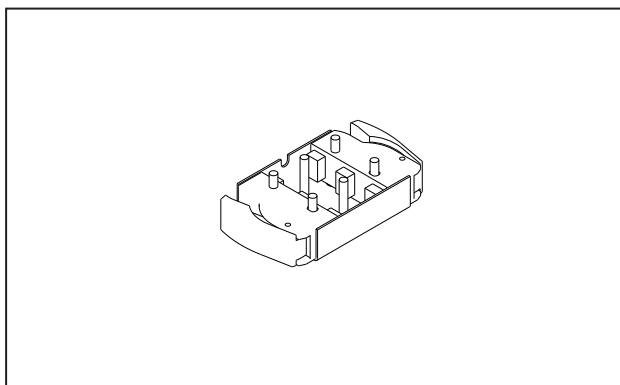

	<b>HAND SWITCH - ASSEMBLY</b>		<b>KIT ATLAS SINGLE - HANDED SWITCH</b>
○	50.9027.0.050	✓	03.5550.0.004

# ACCESSORIES

<b>HAND SWITCH - ASSEMBLY</b>		<b>KIT ATLAS SINGLE - HANDED SWITCH</b>	
○	50.9027.0.050	○	03.5550.0.004

<b>KIT FOR LOOPS OF 15-30 mm LENGTH</b>	
○	03.5550.0.006

✓	FACTORY SET UP
●	STANDARD ACCESSORY
○	OPTIONAL ACCESSORY



**INDEX**

PART NUMBER	PAGE	DET	QTY	PART NUMBER	PAGE	DET	QTY	PART NUMBER	PAGE	DET	QTY
23231217	3-19	42	2	08.6000.3.006	3-45	1	2	08.6002.4.006	3-73	2	3
27378629	3-11	24	(1)	08.6000.4.006	3-69	2	1	08.6002.4.006	3-75	5	(1)
27378629	3-23	31	1	08.6000.4.030	3-61	2	(2)	08.6002.4.008	3-19	02	3
27378629	3-25	31	1	08.6000.4.030	3-63	2	(2)	08.6002.4.008	3-23	3	4
27378629	3-93	04	2	08.6000.6.012	3-3	28	(2)	08.6002.4.008	3-25	3	4
49910018	3-91	12	1	08.6000.6.012	3-67	1	4	08.6002.4.008	3-29	6	3
02.0128.1.113	3-91	01	10	08.6000.6.018	3-53	9	(4)	08.6002.4.008	3-31	01	2
02.0128.1.113	3-96	0	0	08.6000.6.080	3-9	2	1	08.6002.4.008	3-37	06	8
02.0134.1.112	3-5	13	(1)	08.6000.8.016	3-45	2	4	08.6002.4.008	3-39	04	4
02.0134.1.112	3-7	03	(1)	08.6000.8.018	3-33	01	4	08.6002.4.008	3-43	2	3
02.1340.1.112	3-91	02	10	08.6000.8.025	3-37	03	3	08.6002.4.008	3-47	01	6
02.1340.1.112	3-96	0	0	08.6000.8.110	3-19	01	4	08.6002.4.010	3-5	01	1
03.5550.0.003	3-98	0	0	08.6002.0.075	3-33	02	4	08.6002.4.010	3-7	01	15
03.5550.0.004	3-33	27	1	08.6002.3.006	3-21	51	(2)	08.6002.4.010	3-19	03	4 + (4)
03.5550.0.004	3-75	19	1	08.6002.3.006	3-23	2	1	08.6002.4.010	3-37	07	17
03.5550.0.004	3-98	0	0	08.6002.3.006	3-25	2	1	08.6002.4.010	3-39	5	4
03.5550.0.006	3-99	0	0	08.6002.3.006	3-27	01	1	08.6002.4.010	3-51	2	1
03.5550.0.007	3-99	0	0	08.6002.3.006	3-29	5	4	08.6002.4.010	3-53	31	(18)
03.5550.0.008	3-99	0	0	08.6002.3.006	3-39	01	30	08.6002.4.010	3-57	6	3
04.9015.0.362	3-81	01	4	08.6002.3.006	3-51	1	1	08.6002.4.010	3-65	2	4
04.9015.0.363	3-81	02	4	08.6002.3.006	3-77	01	2	08.6002.4.010	3-67	2	4
04.9050.0.050	3-81	03	1	08.6002.3.008	3-27	02	2	08.6002.4.010	3-75	6	(2)
04.9050.0.900	3-81	04	1	08.6002.3.008	3-39	2	2	08.6002.4.012	3-5	02	2
05.1322.0.000	3-29	1	1	08.6002.3.008	3-77	02	9	08.6002.4.012	3-21	53	(12)
05.1322.0.000	3-91	03	1	08.6002.3.010	3-77	03	18	08.6002.4.012	3-27	03	1
06.0120.0.000	3-75	1	(1)	08.6002.3.012	3-15	1	2	08.6002.4.012	3-37	08	8
06.5000.0.007	3-81	05	1	08.6002.3.012	3-29	45	2	08.6002.4.012	3-39	06	4
06.5000.0.021	3-37	01	1	08.6002.3.012	3-37	04	2	08.6002.4.012	3-53	32	(4)
06.5000.0.023	3-71	1	1	08.6002.3.012	3-57	2	2	08.6002.4.012	3-57	7	4
06.5000.0.024	3-9	1	1	08.6002.3.014	3-75	2	(2)	08.6002.4.012	3-73	1	5
06.5000.0.026	3-57	1	1	08.6002.3.018	3-65	1	2	08.6002.4.012	3-75	7	(3)
06.5000.0.055	3-83	01	1	08.6002.3.020	3-17	1	2	08.6002.4.014	3-5	03	1
06.8050.0.001	3-89	10	1	08.6002.3.020	3-77	04	4	08.6002.4.014	3-37	09	4
06.8050.0.002	3-73	19	(1)	08.6002.3.022	3-37	05	2	08.6002.4.014	3-63	3	(2)
06.8050.0.003	3-89	01	1	08.6002.3.022	3-41	52	8	08.6002.4.016	3-35	1	6
06.8050.0.004	3-87	05	1	08.6002.3.025	3-13	1	4	08.6002.4.016	3-43	3	1
07.0000.0.024	3-69	1	4	08.6002.3.025	3-33	29	(1)	08.6002.4.016	3-67	9	(2)
07.0400.0.000	3-23	1	0	08.6002.3.025	3-57	3	2	08.6002.4.016	3-69	3	8
07.0400.0.000	3-25	1	0	08.6002.3.030	3-75	3	(1)	08.6002.4.016	3-77	05	3
07.0400.0.000	3-29	2	0	08.6002.3.060	3-57	4	2	08.6002.4.020	3-7	13	(4)
07.0400.0.000	3-29	3	0	08.6002.4.005	3-29	43	1	08.6002.4.020	3-29	39	1
07.0400.0.000	3-29	4	0	08.6002.4.005	3-75	4	(2)	08.6002.4.020	3-33	03	2
07.6600.0.004	3-37	02	1	08.6002.4.006	3-39	03	1	08.6002.4.020	3-37	10	8
07.6600.0.004	3-43	1	1	08.6002.4.006	3-57	5	4	08.6002.4.020	3-57	8	1
07.6600.0.004	3-83	02	4	08.6002.4.006	3-71	2	1	08.6002.4.020	3-59	1	(2)

## INDEX

PART NUMBER	PAGE	DET	QTY	PART NUMBER	PAGE	DET	QTY	PART NUMBER	PAGE	DET	QTY
08.6002.4.020	3-77	06	1	08.6002.6.016	3-17	10	(2)	08.6202.3.005	3-33	07	3
08.6002.4.022	3-47	02	4	08.6002.6.020	3-21	50	(1)	08.6202.3.006	3-17	11	(2)
08.6002.4.022	3-65	3	4	08.6002.6.020	3-53	33	(3)	08.6202.3.006	3-27	07	2
08.6002.4.025	3-21	49	(4)	08.6002.6.020	3-73	3	6	08.6202.3.006	3-33	44	4
08.6002.4.025	3-27	04	2	08.6002.6.022	3-39	09	4	08.6202.3.006	3-57	9	3
08.6002.4.025	3-61	3	(2)	08.6002.6.022	3-43	5	4	08.6202.3.006	3-63	5	(3)
08.6002.4.025	3-77	07	4	08.6002.6.025	3-45	3	4	08.6202.3.008	3-19	43	(2) + (2)
08.6002.4.030	3-85	01	4	08.6002.7.006	3-39	10	1	08.6202.3.008	3-33	45	2
08.6002.4.033	3-59	1	(2)	08.6002.8.018	3-31	03	4	08.6202.3.008	3-49	1	4
08.6002.4.035	3-33	04	2	08.6012.3.006	3-33	40	2	08.6202.3.010	3-33	46	1
08.6002.4.035	3-67	24	(2)	08.6012.4.008	3-15	2	3	08.6202.3.012	3-9	5	2
08.6002.4.045	3-47	03	3	08.6012.4.010	3-23	32	(1)	08.6202.4.006	3-11	23	(1)
08.6002.4.060	3-33	05	4	08.6012.4.010	3-25	32	(1)	08.6202.4.006	3-35	2	8
08.6002.5.010	3-9	3	4	08.6012.7.004	3-61	14	(1)	08.6202.4.006	3-47	06	6
08.6002.5.010	3-71	3	12	08.6012.7.004	3-64	21	(1)	08.6202.4.006	3-53	35	(2)
08.6002.5.012	3-3	1	1	08.6012.7.012	3-39	11	4	08.6202.4.008	3-5	04	2
08.6002.5.012	3-29	7	2	08.6032.3.005	3-83	04	4	08.6202.4.008	3-7	02	4
08.6002.5.012	3-31	02	1	08.6032.3.008	3-83	05	4	08.6202.4.008	3-9	6	2
08.6002.5.012	3-37	11	2	08.6032.4.008	3-71	5	3	08.6202.4.008	3-15	13	(2)
08.6002.5.012	3-69	4	2	08.6032.4.008	3-81	06	2	08.6202.4.008	3-39	12	4
08.6002.5.012	3-77	08	3	08.6032.4.008	3-83	06	4	08.6202.4.008	3-51	3	2
08.6002.5.012	3-83	03	4	08.6032.4.008	3-85	02	2	08.6202.4.008	3-53	3	4
08.6002.5.014	3-77	09	2	08.6032.4.010	3-37	15	5	08.6202.4.008	3-67	18	(3)
08.6002.5.016	3-19	04	1	08.6032.4.010	3-65	7	1	08.6202.4.010	3-11	1	1
08.6002.5.016	3-27	05	2	08.6032.4.010	3-73	15	(3)	08.6202.4.010	3-15	14	(2)
08.6002.5.016	3-37	12	11	08.6050.4.006	3-47	04	2	08.6202.4.010	3-49	2	2
08.6002.5.016	3-39	07	4	08.6100.3.010	3-63	4	(2)	08.6202.4.012	3-59	2	(1)
08.6002.5.016	3-43	4	3	08.6102.3.006	3-27	06	1	08.6202.5.006	3-51	4	2
08.6002.5.016	3-65	4	2	08.6102.4.010	3-13	2	3	08.6202.5.016	3-31	23	(1)+(1)
08.6002.5.016	3-77	10	10	08.6102.4.010	3-29	42	2	08.6312.5.012	3-17	12	(2)
08.6002.5.018	3-37	13	4	08.6102.4.010	3-65	8	2	08.6312.6.012	3-53	36	(4)
08.6002.5.018	3-77	11	2	08.6102.4.010	3-77	14	4	08.6400.3.004	3-57	10	1
08.6002.5.020	3-37	14	7	08.6102.4.012	3-11	22	(3)	08.6400.3.004	3-61	4	(1)
08.6002.5.020	3-65	5	2	08.6102.4.012	3-31	04	2	08.6400.3.004	3-63	6	(1)
08.6002.5.020	3-71	4	10	08.6102.4.016	3-53	34	(1)	08.6400.3.005	3-57	11	1
08.6002.5.020	3-73	13	(3)	08.6102.4.035	3-77	15	4	08.6400.3.005	3-59	3	(3)
08.6002.5.020	3-77	12	2	08.6102.5.010	3-29	8	2	08.6400.3.006	3-77	16	4
08.6002.5.025	3-31	25	(2)	08.6102.5.012	3-31	20	(2)	08.6400.4.004	3-47	07	3
08.6002.5.025	3-33	06	4	08.6102.6.012	3-53	11	(4)	08.6400.4.004	3-51	5	2
08.6002.5.025	3-65	6	2	08.6102.8.016	3-53	12	(1)	08.6400.4.004	3-77	17	2
08.6002.5.025	3-77	13	4	08.6112.3.006	3-47	05	6	08.6400.4.006	3-13	25	1
08.6002.5.035	3-39	8	2	08.6132.3.005	3-53	1	4	08.6400.4.008	3-23	4	2
08.6002.6.012	3-53	10	(4)	08.6133.3.008	3-53	2	4	08.6400.4.008	3-25	4	2
08.6002.6.012	3-73	14	(1)	08.6200.4.006	3-43	6	11	08.6400.4.035	3-59	4	(1)
08.6002.6.016	3-9	4	4	08.6200.4.008	3-67	3	8	08.6400.5.005	3-3	2	4 + (2)

**INDEX**

PART NUMBER	PAGE	DET	QTY	PART NUMBER	PAGE	DET	QTY	PART NUMBER	PAGE	DET	QTY
08.6400.5.005	3-9	26	(2)	08.6712.4.000	3-47	09	1	08.6832.4.000	3-65	13	1
08.6400.5.005	3-11	2	1+(2)	08.6712.4.000	3-51	7	1	08.6832.4.000	3-71	9	3
08.6400.5.005	3-13	26	2	08.6712.4.000	3-77	18	2	08.6832.4.000	3-75	9	(1)
08.6400.5.005	3-23	5	4	08.6712.5.000	3-65	11	1	08.6832.4.000	3-83	09	3
08.6400.5.005	3-25	5	1	08.6732.4.000	3-29	40	1	08.6832.5.000	3-83	10	4
08.6400.5.005	3-29	9	1	08.6732.4.000	3-81	10	2	08.6842.4.000	3-43	11	1
08.6400.5.005	3-31	22	2	08.6732.4.000	3-85	03	4	08.6842.4.000	3-53	39	(2)
08.6400.5.005	3-49	3	2	08.6772.4.000	3-13	27	1	08.6842.4.000	3-83	11	4
08.6400.5.005	3-51	6	5	08.6772.4.000	3-47	10	1	08.6842.5.000	3-31	05	1+(2)
08.6400.5.005	3-53	37	(1)	08.6772.4.000	3-51	8	1	08.6842.5.000	3-65	14	2
08.6400.5.005	3-65	9	2	08.6772.4.000	3-77	19	2	08.6842.5.000	3-77	22	13
08.6400.5.006	3-43	7	1	08.6792.0.300	3-9	8	1	08.6842.5.000	3-83	12	4
08.6400.5.006	3-45	4	3	08.6792.0.300	3-19	05	1	08.6842.6.000	3-43	12	4
08.6400.5.008	3-9	25	(2)	08.6800.4.000	3-27	24	2	08.6842.6.000	3-67	4	4
08.6400.5.010	3-3	30	(1)	08.6800.5.000	3-27	09	1	08.6850.4.000	3-9	10	2
08.6400.5.010	3-9	27	(2)	08.6800.8.000	3-37	16	3	08.6850.4.000	3-37	20	3
08.6400.5.010	3-11	3	2	08.6800.8.000	3-53	14	(1)	08.6850.8.000	3-37	21	3
08.6400.5.010	3-15	3	1	08.6802.0.000	3-33	08	4	08.6852.0.000	3-81	12	8
08.6400.5.010	3-71	6	1	08.6802.0.000	3-81	11	8	08.6852.3.000	3-9	11	2
08.6400.5.016	3-3	29	(6)	08.6802.3.000	3-39	13	1	08.6852.3.000	3-23	8	1
08.6400.5.016	3-23	6	1	08.6802.4.000	3-5	05	3	08.6852.3.000	3-25	8	1
08.6400.5.016	3-25	6	1	08.6802.4.000	3-7	12	(4)	08.6852.3.000	3-29	11	1
08.6400.5.016	3-65	10	1	08.6802.4.000	3-19	06	2	08.6852.3.000	3-33	09	3+3
08.6400.5.030	3-29	10	2	08.6802.4.000	3-37	17	4	08.6852.3.000	3-39	15	2
08.6400.6.006	3-47	08	1	08.6802.4.000	3-39	14	2	08.6852.3.000	3-51	9	1
08.6400.6.010	3-43	8	1	08.6802.4.000	3-43	9	1	08.6852.3.000	3-77	23	2
08.6400.8.025	3-53	13	(1)	08.6802.4.000	3-57	12	1	08.6852.3.000	3-83	13	8
08.6402.3.006	3-5	22	(1)	08.6802.4.000	3-67	10	(2)	08.6852.4.000	3-5	06	1
08.6402.3.006	3-7	21	(1)	08.6802.4.000	3-75	8	(7)	08.6852.4.000	3-7	04	3
08.6410.5.005	3-23	36	3	08.6802.4.000	3-77	20	4	08.6852.4.000	3-15	16	(2)
08.6410.5.005	3-25	36	3	08.6802.5.000	3-37	18	4	08.6852.4.000	3-19	09	2
08.6552.3.010	3-49	4	1	08.6802.5.000	3-65	12	2	08.6852.4.000	3-23	33	(1)
08.6662.3.006	3-73	16	(1)	08.6802.5.000	3-77	21	21	08.6852.4.000	3-25	33	(1)
08.6663.5.025	3-73	17	(4)	08.6802.6.000	3-9	9	4	08.6852.4.000	3-27	08	1
08.6663.5.025	3-81	07	18	08.6802.6.000	3-45	5	4	08.6852.4.000	3-31	06	2
08.6676.3.020	3-81	08	14	08.6802.6.000	3-53	38	(3)	08.6852.4.000	3-39	16	7
08.6700.5.000	3-23	7	1	08.6802.6.000	3-73	18	(1)	08.6852.4.000	3-43	13	2
08.6700.5.000	3-25	7	1	08.6802.8.000	3-19	07	4	08.6852.4.000	3-47	11	4
08.6702.0.000	3-81	09	8	08.6802.9.300	3-71	8	1	08.6852.4.000	3-53	40	(2)
08.6702.3.000	3-9	7	2	08.6807.3.100	3-33	30	(2)	08.6852.4.000	3-57	13	4
08.6702.3.000	3-17	13	(2)	08.6832.0.000	3-15	15	(1)	08.6852.4.000	3-59	6	(1)
08.6702.3.000	3-83	07	4	08.6832.4.000	3-19	08	3	08.6852.4.000	3-67	11	(2)
08.6702.4.000	3-59	5	(1)	08.6832.4.000	3-29	12	4	08.6852.4.000	3-69	5	1
08.6702.5.000	3-83	08	4	08.6832.4.000	3-37	19	5	08.6852.4.000	3-71	10	1
08.6710.9.500	3-71	7	1	08.6832.4.000	3-43	10	1	08.6852.4.000	3-75	10	(2)

## INDEX

PART NUMBER	PAGE	DET	QTY	PART NUMBER	PAGE	DET	QTY	PART NUMBER	PAGE	DET	QTY
08.6852.4.000	3-81	13	2	12.0008.3.416	3-29	35	1	12.0008.3.749	3-37	27	1
08.6852.4.000	3-85	04	4	12.0008.3.416	3-29	36	1	12.0008.3.749	3-37	28	1
08.6852.5.000	3-17	14	(2)	12.0008.3.416	3-37	22	1	12.0008.3.749	3-37	29	1
08.6852.5.000	3-19	10	1	12.0008.3.416	3-37	23	1	12.0008.3.749	3-37	30	1
08.6852.5.000	3-27	25	2	12.0008.3.416	3-37	24	1	12.0008.3.749	3-39	18	1
08.6852.5.000	3-33	10	4	12.0008.3.416	3-43	14	1	12.0008.3.749	3-39	19	1
08.6852.5.000	3-65	15	1	12.0008.3.416	3-47	12	1	12.0008.3.749	3-39	20	1
08.6852.5.000	3-77	24	2	12.0008.3.416	3-47	13	1	12.0008.3.749	3-39	21	1
08.6852.6.000	3-9	12	4	12.0008.3.416	3-57	14	1	12.0008.3.749	3-39	22	1
08.6852.6.000	3-11	25	(1)	12.0008.3.416	3-57	15	1	12.0008.3.749	3-39	23	1
08.6852.6.000	3-17	15	(3)	12.0008.3.416	3-57	16	1	12.0008.3.749	3-49	5	1
08.6852.6.000	3-21	48	(1)	12.0008.3.416	3-57	17	1	12.0008.3.749	3-49	6	1
08.6852.6.000	3-45	6	4	12.0008.3.416	3-57	18	1	12.0008.3.749	3-49	7	1
08.6852.6.000	3-53	41	(7)	12.0008.3.416	3-57	19	1	12.0008.3.749	3-49	8	1
08.6852.6.000	3-73	4	6	12.0008.3.416	3-57	20	1	12.0008.3.749	3-65	16	1
08.6852.8.000	3-45	7	4	12.0008.3.416	3-57	21	1	12.0008.3.790	3-85	07	1
08.6852.9.000	3-71	11	1	12.0008.3.416	3-67	23	(1)	12.0008.3.798	3-63	7	(2)
08.6882.0.000	3-33	11	4	12.0008.3.416	3-79	59	1	12.0008.3.866	3-49	9	2
08.6887.3.000	3-27	10	2	12.0008.3.416	3-79	60	1	12.0008.4.050	3-89	17	1
08.6887.3.000	3-39	17	1	12.0008.3.416	3-79	61	1	12.0008.4.052	3-31	07	1
08.6887.4.300	3-67	17	(2)	12.0008.3.416	3-79	62	1	12.0008.4.052	3-73	7	1
08.6890.0.000	3-9	13	1	12.0008.3.416	3-79	63	1	12.0008.4.109	3-89	13	2
08.6890.0.000	3-19	11	1	12.0008.3.416	3-79	64	1	12.0008.4.214	3-15	5	1
12.0008.3.170	3-85	05	9	12.0008.3.418	3-83	14	1	12.0008.4.214	3-69	8	1
12.0008.3.275	3-73	5	1	12.0008.3.426	3-85	06	6	12.0008.4.222	3-73	8	1
12.0008.3.276	3-73	6	1	12.0008.3.431	3-45	8	1	12.0008.4.277	3-37	31	4
12.0008.3.409	3-61	5	(2)	12.0008.3.431	3-45	9	1	12.0008.4.277	3-43	15	1
12.0008.3.415	3-53	15	(1)	12.0008.3.431	3-83	15	0	12.0008.4.277	3-65	17	1
12.0008.3.415	3-53	16	(1)	12.0008.3.431	3-83	16	0	12.0008.4.277	3-71	14	3
12.0008.3.415	3-53	17	(1)	12.0008.3.431	3-83	17	0	12.0008.4.280	3-19	16	3
12.0008.3.415	3-53	18	(1)	12.0008.3.431	3-83	18	0	12.0008.4.290	3-19	17	1
12.0008.3.415	3-53	19	(1)	12.0008.3.435	3-83	19	1	12.0008.4.290	3-75	11	(2)
12.0008.3.415	3-53	20	(1)	12.0008.3.499	3-17	16	(2)	12.0008.4.290	3-83	20	3
12.0008.3.415	3-53	21	(1)	12.0008.3.749	3-13	4	1	12.0008.4.470	3-87	07	2
12.0008.3.415	3-53	22	(1)	12.0008.3.749	3-13	5	1	12.0008.4.624	3-75	12	(2)
12.0008.3.415	3-69	6	1	12.0008.3.749	3-15	4	1	12.0008.4.664	3-89	14	1
12.0008.3.415	3-69	7	1	12.0008.3.749	3-15	17	(1)	12.0008.4.664	3-89	16	2
12.0008.3.415	3-71	12	1	12.0008.3.749	3-17	2	1	12.0008.4.682	3-87	01	1
12.0008.3.415	3-71	13	1	12.0008.3.749	3-17	3	1	12.0008.4.691	3-87	10	1
12.0008.3.416	3-19	12	1	12.0008.3.749	3-17	4	1	12.0008.4.741	3-87	02	1
12.0008.3.416	3-19	13	1	12.0008.3.749	3-17	5	1	12.0008.4.741	3-87	04	1
12.0008.3.416	3-19	14	1	12.0008.3.749	3-17	6	1	12.0008.4.751	3-89	04	1
12.0008.3.416	3-19	15	1	12.0008.3.749	3-17	7	1	12.0008.4.833	3-89	02	1
12.0008.3.416	3-29	13	1	12.0008.3.749	3-37	25	1	12.0008.4.898	3-89	05	4
12.0008.3.416	3-29	14	1	12.0008.3.749	3-37	26	1	12.0008.4.913	3-29	15	4



**INDEX**

PART NUMBER	PAGE	DET	QTY	PART NUMBER	PAGE	DET	QTY	PART NUMBER	PAGE	DET	QTY
12.0008.4.913	3-75	13	(1)	12.0010.3.119	3-47	15	2	12.0010.4.287	3-37	35	1
12.0008.6.001	3-91	04	1	12.0010.3.142	3-45	10	2	12.0010.4.288	3-87	09	1
12.0008.6.003	3-91	05	1	12.0010.3.142	3-83	21	2	12.0010.4.301	3-83	28	4
12.0008.6.005	3-91	06	1	12.0010.3.148	3-37	32	3	12.0010.4.324	3-33	47	1
12.0008.6.108	3-91	07	1	12.0010.3.155	3-83	22	1	12.0010.6.230	3-37	36	1
12.0008.6.109	3-91	08	1	12.0010.3.175	3-15	19	(1)	12.0010.6.231	3-35	3	1
12.0008.6.111	3-91	09	1	12.0010.3.176	3-69	10	1	12.0010.6.923	3-53	8	1
12.0008.6.200	3-91	10	1	12.0010.3.177	3-71	16	1	12.0010.6.924	3-73	20	(1)
12.0008.6.215	3-91	11	1	12.0010.3.182	3-65	19	1	12.1010.0.614	3-49	11	2
12.0008.6.232	3-77	25	1	12.0010.3.187	3-39	25	2	12.1010.0.820	3-33	12	2
12.0008.6.812	3-29	16	1	12.0010.3.191	3-67	21	(1)	12.1010.2.024	3-47	16	1
12.0008.6.822	3-11	26	(1)	12.0010.3.198	3-85	13	1	12.1010.2.030	3-67	19	(1)
12.0008.6.823	3-11	27	(1)	12.0010.3.199	3-85	14	1	12.1010.2.043	3-13	8	1
12.0010.3.013	3-13	6	2	12.0010.3.200	3-53	24	(1)	12.1010.2.045	3-67	14	(1)
12.0010.3.027	3-29	17	1	12.0010.3.201	3-53	25	(1)	12.1016.0.000	3-33	13	2
12.0010.3.027	3-77	26	2	12.0010.3.202	3-53	26	(1)	12.1040.1.010	3-25	9	1
12.0010.3.028	3-29	18	1	12.0010.3.203	3-53	27	(2)	12.1040.1.012	3-23	9	1
12.0010.3.028	3-43	16	1	12.0010.3.212	3-85	15	1	12.1040.1.013	3-9	14	2
12.0010.3.028	3-77	27	2	12.0010.3.213	3-85	16	1	12.1040.1.013	3-19	18	4
12.0010.3.029	3-37	49	1	12.0010.3.214	3-83	23	1	12.1040.1.016	3-3	3	4
12.0010.3.029	3-57	22	1	12.0010.3.215	3-83	24	1	12.1045.0.005	3-51	11	1
12.0010.3.036	3-27	11	1	12.0010.3.216	3-83	25	1	12.1045.0.007	3-19	19	1
12.0010.3.036	3-67	22	(1)	12.0010.3.217	3-83	26	1	12.1045.1.014	3-3	4	1
12.0010.3.037	3-57	23	2	12.0010.3.218	3-83	27	1	12.1045.1.014	3-25	10	1
12.0010.3.037	3-77	28	2	12.0010.3.227	3-59	7	(2)	12.1045.1.015	3-71	18	1
12.0010.3.043	3-53	23	(6)	12.0010.3.230	3-29	20	1	12.1045.1.017	3-23	10	1
12.0010.3.043	3-69	9	2	12.0010.4.025	3-37	33	2	12.1050.0.002	3-51	12	1
12.0010.3.043	3-71	15	2	12.0010.4.025	3-57	24	1	12.1050.0.006	3-3	5	2
12.0010.3.044	3-47	14	1	12.0010.4.093	3-31	08	2	12.1050.0.009	3-3	6	2
12.0010.3.064	3-15	18	(1)	12.0010.4.093	3-39	26	1	12.1050.0.010	3-19	20	3
12.0010.3.064	3-17	17	(4)	12.0010.4.093	3-51	10	1	12.2010.0.000	3-71	19	1
12.0010.3.065	3-15	6	1	12.0010.4.093	3-69	11	1	12.2010.0.007	3-23	11	2
12.0010.3.065	3-17	8	2	12.0010.4.154	3-87	08	1	12.2010.0.019	3-39	28	1
12.0010.3.071	3-13	7	2	12.0010.4.161	3-89	06	1	12.2010.0.023	3-71	20	2
12.0010.3.072	3-39	24	4	12.0010.4.162	3-87	06	1	12.2010.0.042	3-3	7	5
12.0010.3.072	3-49	10	4	12.0010.4.163	3-89	11	1	12.2010.0.043	3-11	28	(2)
12.0010.3.072	3-65	18	1	12.0010.4.168	3-89	03	1	12.2010.0.045	3-25	11	2
12.0010.3.078	3-77	29	2	12.0010.4.177	3-37	34	1	12.2010.0.046	3-9	15	2
12.0010.3.090	3-29	19	2	12.0010.4.200	3-87	03	1	12.2010.0.046	3-19	21	2
12.0010.3.098	3-85	08	10	12.0010.4.259	3-89	15	1	12.2050.0.007	3-19	22	2
12.0010.3.099	3-85	09	6	12.0010.4.276	3-39	27	1	12.2050.0.014	3-11	4	2
12.0010.3.105	3-85	10	19	12.0010.4.281	3-89	08	1	12.2050.0.015	3-23	12	1
12.0010.3.106	3-85	11	2	12.0010.4.282	3-89	09	2	12.2050.0.015	3-25	12	1
12.0010.3.116	3-85	12	2	12.0010.4.283	3-89	12	1	12.2070.0.023	3-57	25	2
12.0010.3.119	3-27	12	1	12.0010.4.284	3-89	07	2	12.2070.0.024	3-57	26	1

## INDEX

PART NUMBER	PAGE	DET	QTY	PART NUMBER	PAGE	DET	QTY	PART NUMBER	PAGE	DET	QTY
12.2070.1.039	3-77	30	1	12.9900.9.016	3-13	14	4	50.0011.0.400	3-3	22	1
12.2070.1.044	3-77	31	1	12.9900.9.017	3-13	15	1	50.0012.0.400	3-3	23	1
12.2070.1.048	3-37	37	5	12.9900.9.018	3-13	16	1	50.0013.0.400	3-3	24	1
12.2070.1.049	3-37	38	1	12.9900.9.021	3-13	3	2	50.0014.0.600	3-3	25	1
12.2070.1.051	3-21	55	(1)	15.1123.0.800	3-37	39	1	50.0015.0.300	3-5	16	(1)
12.2070.1.052	3-7	05	1	15.1130.0.400	3-29	21	1	50.0015.0.300	3-7	16	(1)
12.2070.1.053	3-53	42	(1)	15.1145.0.800	3-31	12	1	50.0016.1.300	3-5	17	(1)
12.2070.1.054	3-39	29	2	15.1146.0.400	3-3	11	1	50.0016.1.300	3-7	19	(1)
12.2070.1.060	3-39	30	2	15.1321.0.400	3-11	8	2	50.0017.0.100	3-5	18	(1)
12.2070.1.064	3-77	32	2	15.1321.0.400	3-13	17	4	50.0017.0.100	3-7	20	(1)
12.2080.0.016	3-71	21	1	15.1410.0.992	3-33	31	(1)	50.0018.0.800	3-5	19	(1)
12.2080.0.020	3-47	17	6	15.1416.0.902	3-33	32	(1)	50.0018.0.800	3-7	11	(1)
12.2080.0.022	3-5	07	1	15.1420.0.100	3-11	9	2	50.0019.0.600	3-5	08	1
12.2080.0.022	3-7	06	1	15.1420.0.100	3-33	15	16	50.0020.0.991	3-5	09	2
12.2080.0.028	3-5	15	(1)	15.1422.0.100	3-33	33	(2)	50.0021.0.800	3-5	20	1
12.2080.0.028	3-7	15	(1)	15.1423.0.100	3-33	34	(2)	50.0022.0.991	3-5	21	1
12.2086.0.001	3-3	8	4	15.1427.0.100	3-11	10	3	50.0023.0.600	3-7	07	1
12.2099.3.007	3-71	22	1	15.1436.0.100	3-19	25	2	50.0024.0.800	3-17	18	(1)
12.3010.0.030	3-11	29	(1)	15.5004.0.600	3-45	11	1	50.0025.0.000	3-3	26	2
12.3010.0.031	3-11	30	(1)	15.6005.0.990	3-81	16	4	50.0026.0.800	3-7	08	1
12.3010.0.032	3-23	13	1	15.7002.0.000	3-45	12	1	50.0026.0.800	3-71	23	1
12.3010.0.032	3-25	13	1	17.0012.0.688	3-13	18	2	50.0027.0.991	3-7	09	2
12.3010.0.035	3-65	20	1	17.0026.2.072	3-13	19	2	50.0028.0.600	3-7	10	1
12.4010.0.004	3-81	14	8	17.0082.8.082	3-11	12	1	50.0029.0.400	3-3	27	1
12.4030.0.001	3-3	9	1	17.0094.0.200	3-81	17	4	50.0030.0.000	3-9	18	1
12.4030.0.001	3-19	23	1	17.0095.1.329	3-29	22	2	50.0031.0.500	3-9	19	1
12.4030.0.322	3-19	24	1	17.0097.5.174	3-35	10	1	50.0032.0.500	3-9	20	1
12.4030.0.514	3-3	10	1	17.0097.5.174	3-55	52	1	50.0032.0.500	3-19	26	1
12.5050.2.039	3-31	09	1	17.0097.5.174	3-67	25	1	50.0033.0.990	3-29	25	1
12.5050.2.040	3-31	10	1	19.0044.1.623	3-11	13	1	50.0034.0.300	3-9	21	1
12.5050.2.041	3-31	11	1	19.0044.5.404	3-29	23	1	50.0035.0.400	3-5	10	1
12.5050.2.042	3-9	16	1	22.0229.0.000	3-29	24	5	50.0035.0.400	3-7	17	1
12.8000.0.409	3-43	29	1	24.0120.0.000	3-11	11	1	50.0036.0.000	3-9	22	1
12.8000.0.437	3-79	65	2	24.0168.0.000	3-73	21	(3)	50.0037.0.800	3-9	23	1
12.8000.0.446	3-85	17	1	24.0169.0.000	3-73	22	(1)	50.0038.0.600	3-31	19	(1)
12.8000.1.049	3-33	14	1	50.0001.0.300	3-3	12	1	50.0039.0.600	3-31	24	(1)
12.9900.9.000	3-81	15	1	50.0002.0.600	3-3	13	2	50.0042.0.300	3-11	14	1
12.9900.9.001	3-11	5	1	50.0003.0.300	3-3	14	1	50.0043.0.000	3-11	15	1
12.9900.9.002	3-11	6	1	50.0004.0.300	3-3	15	1	50.0044.0.800	3-11	16	1
12.9900.9.003	3-11	7	1	50.0005.0.600	3-3	16	2	50.0045.0.991	3-29	26	1
12.9900.9.011	3-13	9	2	50.0006.0.300	3-3	17	1	50.0046.0.800	3-11	17	1
12.9900.9.012	3-13	10	2	50.0007.0.500	3-3	18	1	50.0047.0.800	3-11	18	1
12.9900.9.013	3-13	11	2	50.0007.0.500	3-9	17	1	50.0048.0.300	3-11	19	1
12.9900.9.014	3-13	12	2	50.0008.0.400	3-3	19	1	50.0050.0.800	3-15	7	2
12.9900.9.015	3-13	13	2	50.0009.0.600	3-3	20	1	50.0051.0.800	3-15	8	1

**INDEX**

PART NUMBER	PAGE	DET	QTY	PART NUMBER	PAGE	DET	QTY	PART NUMBER	PAGE	DET	QTY
50.0052.0.300	3-15	9	1	50.0098.0.800	3-19	33	1	50.0136.0.800	3-25	29	1
50.0053.0.800	3-13	20	1	50.0099.0.400	3-3	21	1	50.0137.0.800	3-17	22	(2)
50.0054.0.300	3-13	21	1	50.0100.0.400	3-9	24	1	50.0138.0.800	3-17	23	(2)
50.0055.0.300	3-13	22	1	50.0100.0.400	3-19	34	2	50.0139.0.300	3-27	13	1
50.0056.0.800	3-11	20	1	50.0101.0.800	3-21	56	(1)	50.0145.0.990	3-29	27	0
50.0057.0.600	3-13	23	2	50.0102.0.500	3-19	35	1	50.0145.0.990	3-29	28	0
50.0058.0.300	3-13	28	1	50.0103.0.500	3-19	36	1	50.0145.0.990	3-29	29	0
50.0059.0.400	3-13	29	1	50.0105.0.600	3-21	47	(1)	50.0145.0.990	3-29	30	0
50.0060.0.400	3-13	30	1	50.0106.0.600	3-21	54	(1)	50.0146.0.800	3-81	18	2
50.0061.0.400	3-13	31	2	50.0107.0.600	3-23	15	1	50.0147.0.800	3-17	24	(1)
50.0062.0.400	3-13	32	1	50.0108.0.600	3-25	15	1	50.0148.0.800	3-17	25	(1)
50.0063.0.200	3-13	33	1	50.0109.0.500	3-23	16	1	50.0149.0.800	3-29	31	1
50.0064.0.200	3-13	34	1	50.0109.0.500	3-25	16	1	50.0150.0.600	3-33	16	1
50.0065.0.800	3-13	35	1	50.0110.0.500	3-23	17	1	50.0152.0.600	3-27	14	1
50.0066.0.800	3-31	13	1	50.0111.0.500	3-25	17	1	50.0153.0.800	3-29	32	1
50.0067.0.800	3-31	14	1	50.0112.0.300	3-23	18	1	50.0154.0.400	3-29	33	1
50.0067.0.800	3-69	12	1	50.0113.0.300	3-25	18	1	50.0155.0.000	3-29	34	1
50.0068.0.500	3-31	15	1	50.0114.0.600	3-23	19	1	50.0156.0.000	3-27	15	1
50.0070.0.800	3-15	20	(1)	50.0114.0.600	3-25	19	1	50.0160.0.600	3-27	16	1
50.0071.0.800	3-15	21	(2)	50.0115.0.600	3-23	20	1	50.0161.0.800	3-27	17	1
50.0072.0.300	3-15	22	(1)	50.0115.0.600	3-25	20	1	50.0162.0.800	3-27	18	1
50.0073.0.600	3-11	31	(1)	50.0116.0.300	3-23	21	1	50.0163.0.600	3-27	19	1
50.0074.0.600	3-11	32	(1)	50.0116.0.300	3-25	21	1	50.0164.0.800	3-27	20	1
50.0075.0.400	3-11	33	(1)	50.0117.0.400	3-23	22	1	50.0165.0.800	3-27	21	1
50.0076.0.800	3-11	34	(1)	50.0117.0.400	3-25	22	1	50.0166.0.800	3-27	22	1
50.0077.0.300	3-11	35	(1)	50.0118.0.800	3-23	23	1	50.0168.0.600	3-27	23	1
50.0078.0.992	3-11	36	(1)	50.0118.0.800	3-25	23	1	50.0170.0.600	3-35	4	1
50.0079.0.300	3-11	37	(1)	50.0119.0.400	3-23	24	1	50.0171.0.800	3-35	5	1
50.0080.0.800	3-11	38	(1)	50.0119.0.400	3-25	24	1	50.0172.0.600	3-35	6	1
50.0081.0.000	3-11	39	(1)	50.0120.0.400	3-23	25	1	50.0173.0.000	3-33	17	1
50.0082.0.300	3-11	40	(1)	50.0120.0.400	3-25	25	1	50.0174.0.800	3-33	18	1
50.0083.0.400	3-11	41	(1)	50.0121.0.400	3-23	26	2	50.0175.0.000	3-33	19	1
50.0084.0.800	3-17	19	(1)	50.0121.0.400	3-25	26	2	50.0176.0.000	3-33	20	1
50.0085.0.600	3-17	20	(2)	50.0122.0.400	3-25	27	1	50.0177.0.000	3-33	21	1
50.0086.0.300	3-13	24	1	50.0123.0.400	3-23	27	1	50.0178.0.800	3-33	22	2
50.0087.0.800	3-33	41	1	50.0128.0.000	3-23	14	1	50.0180.0.800	3-33	23	1
50.0088.0.800	3-33	42	1	50.0128.0.000	3-25	14	1	50.0181.0.990	3-33	24	1
50.0089.0.800	3-33	43	1	50.0132.0.600	3-23	28	1	50.0189.0.992	3-33	48	1
50.0091.0.300	3-19	27	1	50.0132.0.600	3-25	28	1	50.0190.0.000	3-37	40	1
50.0092.0.300	3-19	28	1	50.0133.0.400	3-19	37	2	50.0191.0.000	3-37	41	1
50.0093.0.000	3-19	29	1	50.0134.0.800	3-23	34	(1)	50.0192.0.600	3-37	42	1
50.0094.0.800	3-17	21	(1)	50.0134.0.800	3-25	34	(1)	50.0193.0.600	3-37	43	1
50.0095.0.600	3-19	30	1	50.0135.0.991	3-23	35	(1)	50.0194.0.500	3-37	44	1
50.0096.0.600	3-19	31	1	50.0135.0.991	3-25	35	(1)	50.0195.0.600	3-37	45	2
50.0097.0.300	3-19	32	1	50.0136.0.800	3-23	29	1	50.0196.0.800	3-37	46	1

## INDEX

PART NUMBER	PAGE	DET	QTY	PART NUMBER	PAGE	DET	QTY	PART NUMBER	PAGE	DET	QTY
50.0197.0.800	3-37	47	1	50.0255.0.600	3-45	13	1	50.0304.0.600	3-65	26	1
50.0199.0.500	3-37	48	1	50.0256.0.600	3-45	14	1	50.0305.0.600	3-57	34	1
50.0200.0.700	3-31	16	1	50.0257.0.400	3-43	17	1	50.0306.0.600	3-57	35	1
50.0201.0.700	3-19	38	1	50.0258.0.800	3-45	15	1	50.0307.0.600	3-57	36	1
50.0205.0.400	3-31	17	1	50.0259.0.300	3-45	16	2	50.0308.0.600	3-59	8	(1)
50.0206.0.000	3-31	18	1	50.0260.0.000	3-43	18	1	50.0309.0.300	3-55	49	(1)
50.0210.0.600	3-39	31	1	50.0261.0.600	3-51	13	1	50.0310.0.600	3-55	50	(1)
50.0211.0.600	3-39	32	1	50.0262.0.300	3-51	14	1	50.0311.0.400	3-65	27	2
50.0212.0.600	3-39	33	1	50.0264.0.300	3-51	15	1	50.0314.0.400	3-63	18	(1)
50.0213.0.600	3-39	34	1	50.0265.0.600	3-45	17	1	50.0315.0.600	3-63	11	(1)
50.0214.0.600	3-39	35	1	50.0266.0.300	3-43	19	1	50.0316.0.600	3-61	8	(1)
50.0215.0.600	3-39	36	1	50.0267.0.000	3-45	18	1	50.0317.0.600	3-61	9	(1)
50.0216.0.600	3-39	37	2	50.0269.0.300	3-51	16	1	50.0317.0.600	3-63	12	(1)
50.0217.0.600	3-39	38	2	50.0271.0.300	3-51	17	1	50.0318.1.600	3-61	10	(1)
50.0218.0.600	3-39	39	1	50.0272.0.800	3-47	32	2	50.0319.0.500	3-61	11	(1)
50.0219.0.100	3-41	53	4	50.0273.0.800	3-51	18	1	50.0319.0.500	3-63	13	(1)
50.0220.0.600	3-39	40	2	50.0274.0.600	3-51	19	1	50.0320.0.600	3-63	14	(1)
50.0221.0.600	3-39	41	1	50.0275.0.800	3-43	20	1	50.0324.0.000	3-59	9	(1)
50.0222.0.300	3-49	12	1	50.0276.0.800	3-51	20	1	50.0325.1.600	3-63	15	(1)
50.0224.0.600	3-39	42	1	50.0277.0.600	3-53	43	(2)	50.0326.0.300	3-45	19	1
50.0227.0.400	3-39	43	1	50.0278.0.800	3-53	44	(1)	50.0327.0.300	3-43	21	1
50.0228.0.300	3-39	44	1	50.0279.0.800	3-53	45	(1)	50.0327.0.300	3-45	20	2
50.0229.1.800	3-39	45	1	50.0280.0.600	3-53	46	(1)	50.0328.0.000	3-61	12	(1)
50.0232.0.000	3-39	46	2	50.0281.0.600	3-53	28	(1)	50.0328.0.000	3-63	16	(1)
50.0234.0.800	3-41	47	1	50.0282.0.600	3-55	47	(1)	50.0329.1.800	3-73	9	1
50.0235.0.800	3-41	48	1	50.0283.0.600	3-65	21	1	50.0330.0.800	3-69	13	1
50.0236.1.600	3-47	18	1	50.0284.0.800	3-53	29	(1)	50.0331.0.800	3-69	14	1
50.0237.1.600	3-47	19	1	50.0285.0.600	3-65	22	1	50.0332.0.600	3-69	15	2
50.0238.1.600	3-47	20	1	50.0286.0.600	3-55	48	(1)	50.0333.0.300	3-69	16	2
50.0239.0.600	3-47	21	1	50.0287.0.600	3-65	23	1	50.0334.0.800	3-69	17	1
50.0240.0.600	3-47	22	1	50.0288.0.800	3-53	30	(1)	50.0335.0.800	3-71	24	1
50.0241.0.800	3-47	23	1	50.0289.0.300	3-65	24	1	50.0336.0.600	3-71	25	1
50.0242.0.300	3-47	24	1	50.0290.0.990	3-47	33	1	50.0337.0.600	3-71	26	1
50.0243.0.600	3-47	25	2	50.0291.0.800	3-65	25	1	50.0338.0.600	3-71	27	1
50.0244.0.800	3-47	26	1	50.0292.0.600	3-57	27	2	50.0339.0.300	3-71	28	1
50.0245.0.800	3-47	27	1	50.0293.0.300	3-57	28	3	50.0340.0.800	3-71	29	1
50.0246.1.600	3-47	28	1	50.0294.0.500	3-57	29	1	50.0341.0.300	3-71	30	1
50.0247.1.300	3-47	29	4	50.0295.0.600	3-57	30	1	50.0342.0.990	3-71	31	1
50.0248.1.300	3-47	30	1	50.0296.0.600	3-57	31	1	50.0343.0.300	3-71	32	1
50.0249.0.300	3-49	13	1	50.0297.0.600	3-63	8	(1)	50.0344.0.800	3-71	33	1
50.0250.0.600	3-49	14	1	50.0299.0.800	3-61	7	(1)	50.0345.0.000	3-71	17	1
50.0251.0.600	3-49	15	1	50.0299.0.800	3-63	9	(1)	50.0350.0.800	3-83	29	1
50.0252.0.100	3-49	16	2	50.0301.0.800	3-63	10	(1)	50.0360.1.600	3-67	16	(1)
50.0253.0.400	3-49	17	1	50.0302.0.800	3-57	32	1	50.0363.1.600	3-67	13	(1)
50.0254.0.800	3-47	31	1	50.0303.0.300	3-57	33	3	50.0364.0.100	3-59	4	(1)

**INDEX**

PART NUMBER	PAGE	DET	QTY	PART NUMBER	PAGE	DET	QTY	PART NUMBER	PAGE	DET	QTY
50.0365.0.000	3-67	5	1	50.0415.0.000	3-79	54	2	50.9034.0.050	3-35	9	1
50.0366.0.000	3-43	22	1	50.0416.0.800	3-81	20	1	50.9052.1.050	3-43	25	1
50.0367.0.000	3-53	4	1	50.0417.0.100	3-81	21	2	50.9053.0.050	3-43	26	1
50.0368.0.000	3-33	25	1	50.0420.0.400	3-63	19	(2)	50.9054.0.050	3-43	27	1
50.0369.0.300	3-67	20	(1)	50.0421.0.400	3-61	6	(2)	50.9056.0.050	3-53	5	1
50.0370.1.000	3-73	10	1	50.0421.0.400	3-63	17	(2)	50.9057.0.050	3-56	0	0
50.0371.0.000	3-73	11	1	50.0423.0.600	3-35	7	1	50.9058.0.050	3-57	37	1
50.0374.0.800	3-81	19	1	50.0424.0.600	3-29	38	1	50.9058.0.050	3-61	1	1
50.0375.0.000	3-59	9	(1)	50.0425.0.800	3-29	37	1	50.9059.0.050	3-57	38	1
50.0376.0.600	3-51	21	1	50.0426.0.800	3-29	41	1	50.9059.0.050	3-63	1	1
50.0378.0.200	3-51	22	1	50.0427.0.800	3-75	14	(1)	50.9060.0.050	3-53	6	1
50.0379.0.400	3-61	15	(1)	50.0428.0.800	3-75	15	(1)	50.9061.0.050	3-53	7	1
50.0379.0.400	3-65	22	(1)	50.0429.0.300	3-75	16	(1)	50.9064.0.050	3-67	6	1
50.0380.0.000	3-73	23	(1)	50.0430.0.800	3-75	17	(1)	50.9065.0.050	3-67	7	1
50.0381.0.000	3-43	23	1	50.0431.0.300	3-75	18	(1)	50.9066.0.050	3-67	8	1
50.0382.0.800	3-43	24	1	50.0435.0.100	3-61	16	(2)	50.9067.0.050	3-56	0	0
50.0383.0.600	3-33	35	(1)	50.0435.0.100	3-63	23	(2)	50.9068.0.050	3-56	0	0
50.0385.0.600	3-73	24	(1)	50.0436.0.600	3-67	15	(1)	50.9069.0.050	3-55	51	(1)
50.0386.0.800	3-33	26	1	50.0437.0.600	3-67	12	(1)	50.9070.0.050	3-43	28	1
50.0387.0.800	3-19	39	1	50.0438.0.100	3-5	14	(1)	50.9071.0.050	3-56	0	0
50.0388.0.400	3-47	34	2	50.0438.0.100	3-7	18	(1)	50.9072.0.050	3-33	28	1
50.0390.0.800	3-77	33	1	50.7001.0.050	3-81	22	1	50.9073.0.050	3-56	0	0
50.0391.0.000	3-77	34	1	50.7002.0.050	3-83	30	1	50.9074.0.050	3-56	0	0
50.0392.0.000	3-77	35	1	50.7003.0.050	3-83	31	1	50.9077.0.050	3-97	0	0
50.0393.0.600	3-77	36	1	50.9002.0.050	3-5	11	1	50.9078.0.050	3-97	0	0
50.0394.0.800	3-77	37	1	50.9002.0.050	3-7	14	1	50.9079.0.050	3-97	0	0
50.0395.0.800	3-77	38	1	50.9007.0.050	3-15	10	1	50.9080.0.050	3-97	0	0
50.0396.0.600	3-77	39	2	50.9008.0.050	3-15	11	1	50.9081.0.050	3-59	13	1
50.0397.0.600	3-77	40	2	50.9009.0.050	3-15	12	1	50.9081.0.050	3-93	08	1
50.0398.0.600	3-77	41	2	50.9012.0.050	3-11	21	1	50.9081.0.050	3-97	0	0
50.0399.0.600	3-77	42	2	50.9015.0.050	3-19	40	1	50.9082.0.050	3-57	39	1
50.0400.0.600	3-79	58	2	50.9016.0.050	3-19	41	1	50.9082.0.050	3-59	13	1
50.0401.0.600	3-77	43	2	50.9017.0.050	3-19	46	(1)	50.9082.0.050	3-97	0	0
50.0402.0.800	3-51	23	1	50.9018.0.050	3-21	52	(1)	50.9083.0.050	3-97	0	0
50.0402.0.800	3-77	44	2	50.9019.0.050	3-23	30	1	50.9084.0.050	3-97	0	0
50.0403.0.300	3-77	45	2	50.9019.0.050	3-25	30	1	50.9085.0.050	3-57	40	1
50.0404.0.600	3-77	46	1	50.9020.0.050	3-19	45	(1) + (1)	50.9085.0.050	3-61	13	1
50.0405.0.800	3-79	47	1	50.9022.0.050	3-5	12	1	50.9085.0.050	3-63	20	1
50.0406.0.600	3-79	48	1	50.9023.0.050	3-31	21	(1)+(1)	50.9085.0.050	3-97	0	0
50.0407.0.800	3-79	49	1	50.9024.0.050	3-31	27	1	50.9086.0.050	3-57	41	1
50.0408.0.600	3-79	50	1	50.9025.0.050	3-31	26	1	50.9086.0.050	3-97	0	0
50.0409.0.400	3-51	24	1	50.9027.0.050	3-98	0	0	50.9901.0.601	3-19	44	(1) + (1)
50.0409.0.400	3-79	51	2	50.9029.0.050	3-17	9	1	50.9901.0.601	3-96	0	0
50.0410.0.300	3-79	52	2	50.9031.0.050	3-73	12	1	50.9901.0.602	3-93	01	2
50.0411.0.600	3-79	53	1	50.9033.0.050	3-35	8	1	50.9901.0.602	3-96	0	0

## INDEX

PART NUMBER	PAGE	DET	QTY	PART NUMBER	PAGE	DET	QTY	PART NUMBER	PAGE	DET	QTY
50.9902.0.801	3-96	0	0								
50.9902.0.802	3-96	0	0								
50.9902.0.803	3-96	0	0								
50.9902.0.804	3-41	49	2								
50.9902.0.804	3-96	0	0								
50.9903.0.801	3-41	50	1								
50.9903.0.801	3-96	0	0								
50.9903.0.802	3-96	0	0								
50.9903.0.803	3-96	0	0								
50.9904.0.801	3-41	51	1								
50.9904.0.801	3-96	0	0								
50.9904.0.802	3-96	0	0								
50.9904.0.803	3-96	0	0								
50.9905.1.601	3-47	35	1								
50.9905.1.601	3-93	03	1								
50.9906.0.601	3-93	02	1								
50.9906.0.601	3-97	0	0								
50.9906.0.602	3-49	18	1								
50.9906.0.602	3-97	0	0								
50.9907.0.204	3-61	17	(2)								
50.9907.0.204	3-63	24	(2)								
50.9907.0.204	3-93	05	2								
50.9908.0.201	3-59	10	(1)								
50.9908.0.201	3-93	07	1								
50.9909.0.602	3-59	11	(1)								
50.9910.0.602	3-59	11	(1)								
50.9911.0.201	3-59	12	(2)								
50.9911.0.201	3-93	06	2								
50.9914.0.201	3-79	55	2								
50.9914.0.201	3-95	01	2								
50.9915.0.201	3-79	56	1								
50.9915.0.201	3-95	02	1								
50.9916.0.201	3-79	57	1								
50.9916.0.201	3-95	03	1								
50.9917.0.801	3-57	42	2								
50.9919.0.601	3-61	18	(1)								
50.9919.0.601	3-63	25	(1)								
50.9920.0.801	3-41	54	2								
68.0357.0.800	3-73	25	(1)								
73.0082.0.800	3-83	32	1								
84.0003.0.390	3-91	13	1								